

Hydraulic Formulary



Author: Houman Hatami

Tel.: +49-9352-18-1225

Fax: +49-9352-18-1293

houman.hatami@boschrexroth.de

CONTENTS

RELATIONS BETWEEN UNITS.....	4
IMPORTANT CHARACTERISTIC VALUES OF HYDRAULIC FLUIDS.....	6
GENERAL HYDRAULIC RELATIONS.....	7
PISTON PRESSURE FORCE	7
PISTON FORCES	7
HYDRAULIC PRESS.....	7
CONTINUITY EQUATION.....	8
PISTON SPEED.....	8
PRESSURE INTENSIFIER.....	8
HYDRAULIC SYSTEM COMPONENT	9
HYDRO PUMP	9
HYDRO MOTOR.....	9
<i>Hydro motor variable</i>	10
<i>Hydro motor fixed</i>	11
<i>Hydro motor intrinsic frequency</i>	12
HYDRO PISTON.....	13
<i>Differential piston</i>	14
<i>Double acting cylinder</i>	15
<i>Cylinder in differential control</i>	16
<i>Cylinder intrinsic frequency at differential cylinder</i>	17
<i>Cylinder intrinsic frequency at double acting cylinder</i>	18
<i>Cylinder intrinsic frequency at plunger cylinder</i>	19
PIPING.....	20
APPLICATION EXAMPLES FOR SPECIFICATION OF THE CYLINDER PRESSURES AND VOLUME FLOWS UNDER POSITIVE AND NEGATIVE LOADS.....	21
DIFFERENTIAL CYLINDER EXTENDING WITH POSITIVE LOAD	22
DIFFERENTIAL CYLINDER RETRACTING WITH POSITIVE LOAD	23
DIFFERENTIAL CYLINDER EXTENDING WITH NETAGIVE LOAD.....	24
DIFFERENTIAL CYLINDER RETRACTING WITH NEGATIVE LOAD.....	25
DIFFERENTIAL CYLINDER EXTENDING AT AN INCLINED PLANE WITH POSITIVE LOAD	26
DIFFERENTIAL CYLINDER RETRACTING AT AN INCLINED PLANE WITH POSITIVE LOAD.....	27
DIFFERENTIAL CYLINDER EXTENDING AT AN INCLINED PLANE WITH NEGATIVE LOAD	28
DIFFERENTIAL CYLINDER RETRACTING AT AN LINCLINED PBLANE WITH NEGATIVE LOAD.....	29
HYDRAULIC MOTOR WITH POSITIVE LOAD.....	30
HYDRAULIC MOTOR WITH NEGATIVE LOAD.....	31
IDENTIFICATION OF THE REDUCED MASSES OF DIFFERENT SYSTEMS.....	32
LINEARE DRIVES	33
<i>Primary applications (Energy method)</i>	33
<i>Concentrated mass at linear movements</i>	35
<i>Distributed mass at linear movements</i>	36
ROTATION.....	37
COMBINATION OF LINEAR AND ROTATIONAL MOVEMENT	38
HYDRAULIC RESISTANCES.....	39
ORIFICE EQUATION	39
TROTTLER EQUATION.....	39

HYDRO ACCUMULATOR	40
HEAT EXCHANGER (OIL- WATER).....	41
LAYOUT OF A VALVE	43

Relation between Units

Size	Unit	Symbol	Relation
Lengths	Micrometer	μm	$1\mu\text{m} = 0,001\text{mm}$
	Millimeter	mm	$1\text{mm} = 0,1\text{cm} = 0,01\text{dm} = 0,001\text{m}$
	Centimeter	cm	$1\text{cm} = 10\text{mm} = 10.000\mu\text{m}$
	Decimeter	dm	$1\text{dm} = 10\text{cm} = 100\text{mm} = 100.000\mu\text{m}$
	Meter	m	$1\text{m} = 10\text{dm} = 100\text{cm} = 1.000\text{mm} = 1.000.000\mu\text{m}$
	Kilometer	km	$1\text{km} = 1.000\text{m} = 100.000\text{cm} = 1.000.000\text{mm}$
Surfaces	Square centimeter	cm^2	$1\text{cm}^2 = 100\text{mm}^2$
	Square decimeter	dm^2	$1\text{dm}^2 = 100\text{cm}^2 = 10.000\text{mm}^2$
	Square meter	m^2	$1\text{m}^2 = 100\text{dm}^2 = 10.000\text{cm}^2 = 1.000.000\text{mm}^2$
	Are	a	$1\text{a} = 100\text{m}^2$
	Hectare	ha	$1\text{ha} = 100\text{a} = 10.000\text{m}^2$
	Square kilometer	km^2	$1\text{km}^2 = 100\text{ha} = 10.000\text{a} = 1.000.000\text{m}^2$
Volume	Cubic centimeter	cm^3	$1\text{cm}^3 = 1.000\text{mm}^3 = 1\text{ml} = 0,001\text{l}$
	Cubic decimeter	dm^3	$1\text{dm}^3 = 1.000\text{cm}^3 = 1.000.000\text{mm}^3$
	Cubic meter	m^3	$1\text{m}^3 = 1.000\text{dm}^3 = 1.000.000\text{cm}^3$
	Milliliter	ml	$1\text{ml} = 0,001\text{l} = 1\text{cm}^3$
	Liter	l	$1\text{l} = 1.000\text{ml} = 1\text{dm}^3$
	Hectoliter	hl	$1\text{hl} = 100\text{l} = 100\text{dm}^3$
Density	Gram/ Cubic centimeter	$\frac{\text{g}}{\text{cm}^3}$	$1\frac{\text{g}}{\text{cm}^3} = 1\frac{\text{kg}}{\text{dm}^3} = 1\frac{\text{t}}{\text{m}^3} = 1\frac{\text{g}}{\text{ml}}$
Force Weight	Newton	N	$1\text{N} = 1\frac{\text{kg} \cdot \text{m}}{\text{s}^2} = 1\frac{\text{J}}{\text{m}}$ $1\text{daN} = 10\text{N}$
Torque	Newton meter	Nm	$1\text{Nm} = 1\text{J}$
Pressure	Pascal	Pa	$1\text{Pa} = 1\text{N}/\text{m}^2 = 0,01\text{mbar} = \frac{1\text{kg}}{\text{m} \cdot \text{s}^2}$
	Bar	Bar	$1\text{bar} = 10\frac{\text{N}}{\text{cm}^2} = 100.000\frac{\text{N}}{\text{m}^2} = 10^5\text{Pa}$
	$\text{psi} = \frac{\text{pound}}{\text{inch}^2}$	Psi	$1\text{psi} = 0,06895\text{bar}$
	$\frac{\text{kp}}{\text{cm}^2}$		$1\frac{\text{kp}}{\text{cm}^2} = 0,981\text{bar}$

Formulary Hydraulics

Mass	Milligram	mg	1mg = 0,001g
	Gram	g	1g = 1.000mg
	Kilogram	kg	1kg = 1000g = 1.000.000 mg
	Ton	t	1t = 1000kg = 1.000.000g
	Mega gram	Mg	1Mg = 1t
Acceleration	Meter/	$\frac{m}{s^2}$	$1\frac{m}{s^2} = 1\frac{N}{kg}$
	per square second		1g = 9,81 m/s ²
Angular speed	One/ Second	$\frac{1}{s}$	$\omega = 2\pi \cdot n$ n in 1/s
	Radiant/ Second	$\frac{rad}{s}$	
Power	Watt	W	$1W = 1\frac{Nm}{s} = 1\frac{J}{s} = 1\frac{kg \cdot m}{s^2} \cdot \frac{m}{s}$
	Newton meter/ second	Nm/s	
	Joule/ second	J/s	
Work/ Energy	Watt second	Ws	1Ws = 1Nm = 1 $\frac{kg \cdot m}{s^2} \cdot m = 1J$
Heat volume	Newton meter	Nm	
	Joule	J	
	Kilowatt hour	kWh	1kWh = 1.000 Wh = 1000•3600Ws = 3,6•10 ⁶ Ws
	Kilo joule	kJ	= 3,6•10 ³ kJ = 3600kJ = 3,6MJ
	Mega joule	MJ	
Mechanic tension	Newton/ square millimeter	$\frac{N}{mm^2}$	$1\frac{N}{mm^2} = 10bar = 1MPa$
Plane angle	Second	''	1'' = 1'/60
	Minute	'	1' = 60''
	Degree	°	1° = 60' = 3600'' = $\frac{\pi}{180^\circ} rad$
	Radiant	rad	1rad = 1m/m = 57,2957° 1rad = 180°/π
Speed	One/second	1/s	$\frac{1}{s} = s^{-1} = 60min^{-1}$
	One/minute	1/min	$\frac{1}{min} = min^{-1} = \frac{1}{60s}$

Important Characteristic Values of Hydraulic Fluids

	HLP	HFC	HFA (3%)	HFD
Density at 20°C [kg/cm ³]	0,00087	0,00105-0,00108	0,0001	0,000115
Kinematic Viscosity at 40°C [mm ² /s]	10-100	36-50	0,7	15-70
Compressions Module E at 50°C [Bar]	12000-14000	20400-23800	15000- 17500	18000- 21000
Specific Heat at 20°C [kJ/kgK]	2,1	3,3	4,2	1,3-1,5
Thermal Conductivity at 20°C [W/mK]	0,14	0,4	0,6	0,11
Optimal Temperatures [°C]	40-50	35-50	35-50	35-50
Water Content [%]	0	40-50	80-97	0
Cavitation Tendency	low	high	very high	low

General Hydraulic Relations

Piston Pressure Force

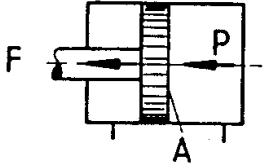
Figure	Equation / Equation Variations	Symbols / Units
	$F = 10 \cdot p \cdot A$ $F = p \cdot A \cdot \eta \cdot 10$ $A = \frac{d^2 \cdot \pi}{4}$ $d = \sqrt{\frac{4 \cdot F \cdot 0,1}{\pi \cdot p}}$ $p = 0,1 \cdot \frac{4 \cdot F}{\pi \cdot d^2}$	<p>F = piston pressure force[N] p = fluid pressure[bar] A = piston surface[cm²] d = piston diameter[cm] η = efficiency cylinder</p>

Piston Forces

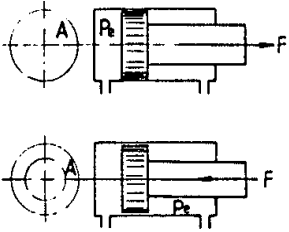
Figure	Equation / Equation Variations	Symbols / Units
	$F = p_e \cdot A \cdot 10$ $F = p_e \cdot A \cdot \eta \cdot 10$ $A = \frac{d^2 \cdot \pi}{4}$ <p>A For annulus surface:</p> $A = \frac{(D^2 - d^2) \cdot \pi}{4}$	<p>F = piston pressure force[N] p_e = excess pressure on the piston[bar] A = effective piston surface[cm²] d = piston diameter[cm] η = efficiency cylinder</p>

Hydraulic Press

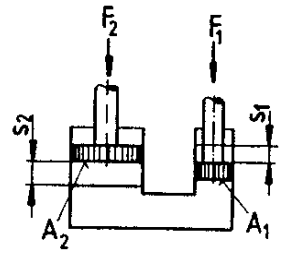
Figure	Equation / Equation Variations	Symbols / Units
	$\frac{F_1}{A_1} = \frac{F_2}{A_2}$ $F_1 \cdot s_1 = F_2 \cdot s_2$ $\varphi = \frac{F_1}{F_2} = \frac{A_1}{A_2} = \frac{s_2}{s_1}$	<p>F₁ = Force at the pump piston[N] F₂ = Force at the operating piston[N] A₁ = Surface of the pump piston [cm²] A₂ = Surface of the operating piston [cm²] s₁ = Stroke of the pump piston [cm] s₂ = Stroke of the operating piston [cm] φ = Gear ratio</p>

Formulary Hydraulics

Continuity Equation

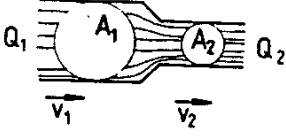
Figure	Equation / Equation Variations	Symbols / Units
	$Q_1 = Q_2$ $Q_1 = A_1 \cdot v_1$ $Q_2 = A_2 \cdot v_2$ $A_1 \cdot v_1 = A_2 \cdot v_2$	<p>$Q_{1,2}$ = Volume flows [cm³/s, dm³/s, m³/s] $A_{1,2}$ = Area surfaces [cm², dm², m²] $v_{1,2}$ = Velocities [cm/s, dm/s, m/s]</p>

Piston Speed

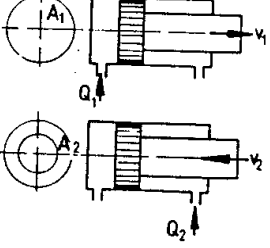
Figure	Equation / Equation Variations	Symbols / Units
	$v_1 = \frac{Q_1}{A_1}$ $v_2 = \frac{Q_2}{A_2}$ $A_1 = \frac{d^2 \cdot \pi}{4}$ $A_2 = \frac{(D^2 - d^2) \cdot \pi}{4}$	<p>$v_{1,2}$ = Piston speed [cm/s] $Q_{1,2}$ = Volume flow [cm³/s] A_1 = Effective piston surface (circle) [cm²] A_2 = Effective piston surface (ring) [cm²]</p>

Pressure Intensifier

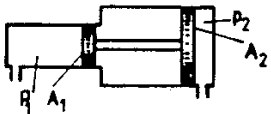
Figure	Equation / Equation Variations	Symbols / Units
	$p_1 \cdot A_1 = p_2 \cdot A_2$	<p>p_1 = Pressure in the small cylinder [bar] A_1 = Piston surface [cm²] p_2 = Pressure at the large cylinder [bar] A_2 = Piston surface [cm²]</p>

Hydraulic System Components

Hydro Pump

$$Q = \frac{V \cdot n \cdot \eta_{vol}}{1000} \text{ [l/min]}$$

$$P_{an} = \frac{p \cdot Q}{600 \cdot \eta_{ges}} \text{ [kW]}$$

$$M = \frac{1,59 \cdot V \cdot \Delta p}{100 \cdot \eta_{mh}} \text{ [Nm]}$$

$$\eta_{ges} = \eta_{vol} \cdot \eta_{mh}$$

Q = Volume flow [l/min]

V = Nominal volume [cm³]

n = Drive speed of the pump [min⁻¹]

P_{an} = Drive power [kW]

p = Service pressure [bar]

M = Drive torque [Nm]

η_{ges} = Total efficiency (0,8-0,85)

η_{vol} = Volumetric efficiency (0,9-0,95)

η_{mh} = Hydro-mechanic efficiency(0,9-0,95)

Hydro Motor

$$Q = \frac{V \cdot n}{1000 \cdot \eta_{vol}}$$

$$n = \frac{Q \cdot \eta_{vol} \cdot 1000}{V}$$

$$M_{ab} = \frac{\Delta p \cdot V \cdot \eta_{mh}}{20 \cdot \pi} = 1,59 \cdot V \cdot \Delta p \cdot \eta_{mh} \cdot 10^{-2}$$

$$P_{ab} = \frac{\Delta p \cdot Q \cdot \eta_{ges}}{600}$$

Q = Volume flow [l/min]

V = Nominal volume [cm³]

n = Drive speed of the pump [min⁻¹]

η_{ges} = Total efficiency (0,8-0,85)

η_{vol} = Volumetric efficiency (0,9-0,95)

η_{mh} = Hydro-mechanic efficiency
(0,9-0,95)

Δp = Pressure difference between motor inlet and outlet (bar)

P_{ab} = Output power of the motor [kW]

M_{ab} = Output torque [Nm]

Hydro Motor Variable

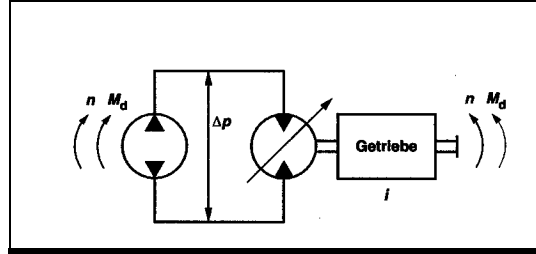

$$M_d = \frac{30000}{\pi} \cdot \frac{P}{n}$$

$$P = \frac{\pi}{30000} \cdot M_d \cdot n$$

$$n = \frac{30000}{\pi} \cdot \frac{P}{M_d}$$

$$M_d = \frac{M_{dmax}}{i \cdot \eta_{Getr}}$$

$$n = \frac{n_{max}}{i}$$

$$\Delta p = 20\pi \cdot \frac{M_d}{V_g \cdot \eta_{mh}}$$

$$Q = \frac{V_g \cdot n}{1000 \cdot \eta_{vol}}$$

$$Q_p = \frac{V_g \cdot n \cdot \eta_{vol}}{1000}$$

$$P = \frac{Q \cdot \Delta p}{600 \cdot \eta_{ges}}$$

M_d = Torque [Nm]

P = Power [kW]

n = Speed [min^{-1}]

M_{dmax} = Max torque [Nm]

i = Gear ratio

η_{Getr} = Gear efficiency

η_{mh} = Mech./hydraulic efficiency

η_{vol} = Vol. efficiency

V_g = Flow volume [cm^3]

Hydro Motor Fixed

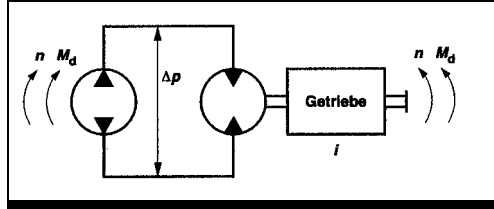

$$M_d = \frac{30000}{\pi} \cdot \frac{P}{n}$$

$$P = \frac{\pi}{30000} \cdot M_d \cdot n$$

$$n = \frac{30000}{\pi} \cdot \frac{P}{M_d}$$

$$M_d = \frac{M_{dmax}}{i \cdot \eta_{Getr}}$$

$$n = \frac{n_{max}}{i}$$

$$\Delta p = 20\pi \cdot \frac{M_d}{V_g \cdot \eta_{mh}}$$

$$Q = \frac{V_g \cdot n}{1000 \cdot \eta_{vol}}$$

$$Q_p = \frac{V_g \cdot n \cdot \eta_{vol}}{1000}$$

$$P = \frac{Q \cdot \Delta p}{600 \cdot \eta_{ges}}$$

M_d = Torque [Nm]

P = Power [kW]

n = Speed [min^{-1}]

M_{dmax} = Max torque [Nm]

i = Gear ratio

η_{Getr} = Gear efficiency

η_{mh} = Mech./hydraulic efficiency

η_{vol} = Vol. efficiency

V_g = Flow volume [cm^3]

Hydro Motor Intrinsic Frequency

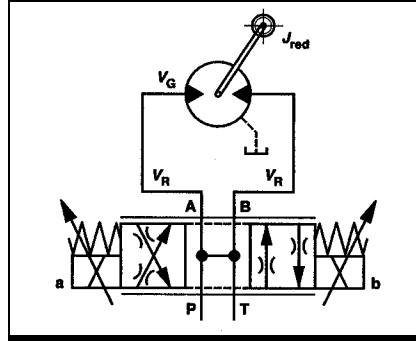

$$\omega_0 = \sqrt{\frac{2 \cdot E}{J_{red}} \cdot \frac{\left(\frac{V_G}{2\pi}\right)^2}{\left(\frac{V_G}{2} + V_R\right)}}$$

$$f_0 = \frac{\omega_0}{2\pi}$$

V_G = Displacement [cm³]

ω_0 = Intrinsic angular frequency [1/s]

f_0 = Intrinsic frequency [Hz]

J_{red} = Moment of inertia red. [kgm²]

E_{oil} = 1400 N/mm²

V_R = Volume of the line [cm³]

Hydro Cylinder

$$A = \frac{d_1^2 \cdot \pi}{400} = \frac{d_1^2 \cdot 0,785}{100} [\text{cm}^2]$$

$$A_{st} = \frac{d_2^2 \cdot 0,785}{100} [\text{cm}^2]$$

$$A_R = \frac{(d_1^2 - d_2^2) \cdot 0,785}{100} [\text{cm}^2]$$

$$F_D = \frac{p \cdot d_1^2 \cdot 0,785}{10000} [\text{kN}]$$

$$F_z = \frac{p \cdot (d_1^2 - d_2^2) \cdot 0,785}{10000} [\text{kN}]$$

$$v = \frac{h}{t \cdot 1000} = \frac{Q}{A \cdot 6} [\text{m/s}]$$

$$Q_{th} = 6 \cdot A \cdot v = \frac{V}{t} \cdot 60 [\text{l/min}]$$

$$Q = \frac{Q_{th}}{\eta_{vol.}}$$

$$V = \frac{A \cdot h}{10000} [l]$$

$$t = \frac{A \cdot h \cdot 6}{Q \cdot 1000} [s]$$

d_1 = Piston diameter [mm]

d_2 = Piston rod diameter [mm]

p = Service pressure [bar]

v = Stroke speed [m/s]

V = Stroke volume [l]

Q = Volume flow, considering the leakages
(l/min)

Q_{th} = Volume flow, without considering the
leakages (l/min)

η_{vol} = Volumetric efficiency (approx. 0,95)

h = Stroke [mm]

t = Stroke time [s]

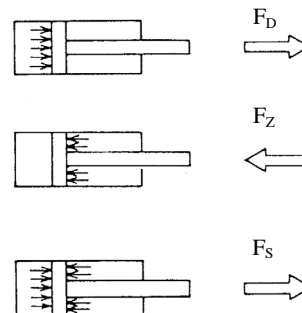

Differential Cylinder

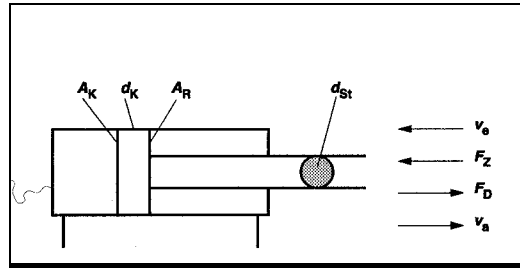

$$d_K = 100 \cdot \sqrt{\frac{4 \cdot F_D}{\pi \cdot p_K}}$$

$$p_K = \frac{4 \cdot 10^4 \cdot F_D}{\pi \cdot d_K^2}$$

$$p_{St} = \frac{4 \cdot 10^4 \cdot F_Z}{\pi \cdot (d_K^2 - d_{St}^2)}$$

$$\varphi = \frac{d_K^2}{(d_K^2 - d_{St}^2)}$$

$$Q_K = \frac{6 \cdot \pi}{400} \cdot v_a \cdot d_K^2$$

$$Q_{St} = \frac{6 \cdot \pi}{400} \cdot v_e \cdot (d_K^2 - d_{St}^2)$$

$$v_e = \frac{Q_{St}}{\frac{6\pi}{400} \cdot (d_K^2 - d_{St}^2)}$$

$$v_a = \frac{Q_K}{\frac{6\pi}{400} \cdot d_K^2}$$

$$Vol_p = \frac{\pi}{4 \cdot 10^6} \cdot d_{St}^2 \cdot h$$

$$Vol_F = \frac{\pi}{4 \cdot 10^6} \cdot h \cdot (d_K^2 - d_{St}^2)$$

d_K = Piston diameter [mm]

d_{St} = Rod diameter [mm]

F_D = Pressure force [kN]

F_Z = Traction force [kN]

p_K = Pressure at the piston side [bar]

φ = Aspect ratio

Q_K = Volume flow piston side [l/min]

Q_{St} = Volume flow rod side [l/min]

v_a = Extending speed [m/s]

v_e = Retracting speed [m/s]

Vol_p = Working volume [l]

Vol_F = Fill-up volume [l]

h = Stroke [mm]

Double Acting Cylinder

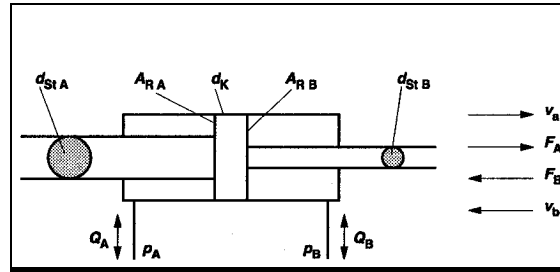

$$p_A = \frac{4 \cdot 10^4}{\pi} \cdot \frac{F_A}{(d_K^2 - d_{StA}^2)}$$

$$p_B = \frac{4 \cdot 10^4}{\pi} \cdot \frac{F_B}{(d_K^2 - d_{StB}^2)}$$

$$Q_A = \frac{6 \cdot \pi}{400} \cdot v_a \cdot (d_K^2 - d_{StA}^2)$$

$$Q_B = \frac{6 \cdot \pi}{400} \cdot v_b \cdot (d_K^2 - d_{StB}^2)$$

$$v_e = \frac{Q_{St}}{\frac{6\pi}{400} \cdot (d_K^2 - d_{St}^2)}$$

$$v_a = \frac{Q_K}{\frac{6\pi}{400} \cdot d_K^2}$$

$$Vol_p = \frac{\pi}{4 \cdot 10^6} \cdot d_{St}^2 \cdot h$$

$$Vol_{FA} = \frac{\pi}{4 \cdot 10^6} \cdot h \cdot (d_K^2 - d_{StA}^2)$$

$$Vol_{FB} = \frac{\pi}{4 \cdot 10^6} \cdot h \cdot (d_K^2 - d_{StB}^2)$$

d_K = Piston diameter [mm]

d_{StA} = Rod diameter A-side [mm]

d_{StB} = Rod diameter B-side [mm]

F_A = Force A [kN]

F_B = Force B [kN]

p_A = Pressure at the A-side [bar]

p_B = Pressure at the B-side [bar]

Q_A = Volume flow A-side [l/min]

Q_B = Volume flow B-side [l/min]

v_a = Speed a [m/s]

v_b = Speed b [m/s]

Vol_p = Compensating volume [l]

Vol_{FA} = Fill-up volume A [l]

Vol_{FB} = Fill-up volume B [l]

Cylinder in Differential Control

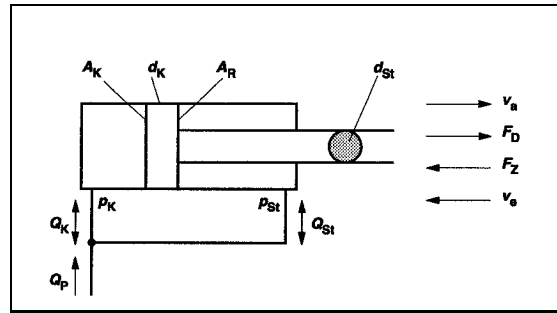

$$d_{st} = 100 \cdot \sqrt{\frac{4 \cdot F_D}{\pi \cdot p_{St}}}$$

$$p_K = \frac{4 \cdot 10^4 \cdot F_D}{\pi \cdot d_{St}^2}$$

$$p_{St} = \frac{4 \cdot 10^4 \cdot F_Z}{\pi \cdot (d_K^2 - d_{St}^2)}$$

$$Q = \frac{6 \cdot \pi}{400} \cdot v_a \cdot d_{St}^2$$

Extension:

$$v_a = \frac{Q_P}{\frac{6\pi}{400} \cdot d_{St}^2}$$

$$Q_K = \frac{Q_P \cdot d_K^2}{d_{St}^2}$$

$$Q_{St} = \frac{Q_P \cdot (d_K^2 - d_{St}^2)}{d_{St}^2}$$

Retraction:

$$v_e = \frac{Q_P}{\frac{6\pi}{400} \cdot (d_K^2 - d_{St}^2)}$$

$$Q_{St} = Q_P$$

$$Q_K = \frac{Q_P \cdot d_K^2}{(d_K^2 - d_{St}^2)}$$

$$Vol_p = \frac{\pi}{4 \cdot 10^6} \cdot d_{St}^2 \cdot h$$

$$Vol_F = \frac{\pi}{4 \cdot 10^6} \cdot h \cdot (d_K^2 - d_{St}^2)$$

d_K = Piston diameter [mm]

d_{St} = Rod diameter [mm]

F_D = Pressure force [kN]

F_Z = Traction force [kN]

p_K = Pressure at the piston side [bar]

p_{St} = Pressure at the rod side [bar]

h = Stroke [mm]

Q_K = Volume flow piston side [l/min]

Q_{St} = Volume flow rod side [l/min]

Q_P = Pump flow [l/min]

v_a = Extending speed [m/s]

v_e = Retracting speed [m/s]

Vol_p = Working volume [l]

Vol_F = Fill-up volume [l]

Cylinder Intrinsic Frequency at Differential Cylinders

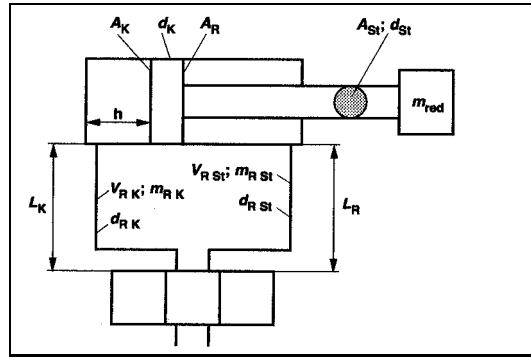

$$A_K = \frac{d_K^2 \pi}{4 \cdot 100}$$

$$A_R = \frac{(d_K^2 - d_{St}^2) \pi}{4 \cdot 100}$$

$$V_{RK} = \frac{d_{RK}^2 \pi}{4} \cdot \frac{L_K}{1000}$$

$$V_{RSt} = \frac{d_{RSt}^2 \pi}{4} \cdot \frac{L_{St}}{1000}$$

$$m_{RK} = \frac{V_{RK} \cdot \rho_{\text{öl}}}{1000}$$

$$m_{RSt} = \frac{V_{RSt} \cdot \rho_{\text{öl}}}{1000}$$

$$h_k = \frac{\left(\frac{A_R \cdot h}{\sqrt{A_R^3}} + \frac{V_{RSt}}{\sqrt{A_R^3}} + \frac{V_{RK}}{\sqrt{A_K^3}} \right)}{\left(\frac{1}{\sqrt{A_R}} + \frac{1}{\sqrt{A_K}} \right)}$$

$$\omega_0 = \sqrt{\frac{1}{m} \cdot \left(\frac{A_K^2 \cdot E_{\text{öl}}}{\frac{A_K \cdot h_k}{10} + V_{RK}} + \frac{A_R^2 \cdot E_{\text{öl}}}{\frac{A_R \cdot h - h_k}{10} + V_{RSt}} \right)}$$

$$f_0 = \frac{\omega_0}{2\pi}$$

$$m_{\text{ölred}} = m_{RK} \left(\frac{d_K}{d_{RK}} \right)^4 + m_{RSt} \left(\frac{1}{d_{RSt}} \sqrt{\frac{400 \cdot A_R}{\pi}} \right)$$

A_K = Piston surface [cm²]

A_R = Piston ring surface [cm²]

d_K = Piston diameter [mm]

d_{St} = Piston rod diameter [mm]

d_{RK} = NW- piston side [mm]

L_K = Length of piston side [mm]

d_{RSt} = NW-rod side [mm]

L_{St} = Length of rod side [mm]

h = Stroke [cm]

V_{RK} = Volume of the line piston side [cm³]

V_{RSt} = Volume of the line rod side [cm³]

m_{RK} = Mass of the oil in the line piston side [kg]

m_{RSt} = Mass of the oil in the line rod side [kg]

h_k = Position at min intrinsic frequency [cm]

f_0 = Intrinsic frequency [Hz]

ω_0 = Angular frequency

$$\omega_{01} = \omega_0 \cdot \sqrt{\frac{m_{\text{red}}}{m_{\text{ölred}} + m_{\text{red}}}}$$

$$f_{01} = \frac{\omega_{01}}{2\pi}$$

Cylinder Intrinsic Frequency at Double Acting Cylinders

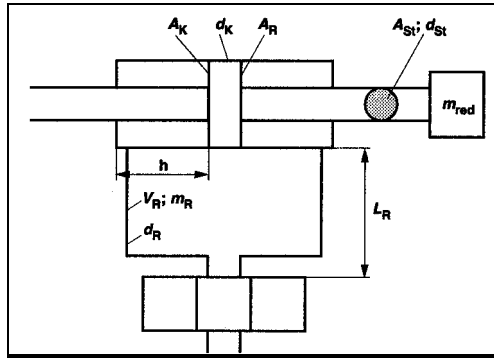

$$A_R = \frac{(d_K^2 - d_{St}^2) \pi}{4}$$

$$V_R = \frac{d_{RK}^2 \pi}{4} \cdot \frac{L_K}{1000}$$

$$m_R = \frac{V_R \cdot \rho_{öl}}{1000}$$

$$\omega_0 = 100 \cdot \sqrt{\frac{2 \cdot E_{öl}}{m_{red}} \cdot \left(\frac{A_R^2}{\frac{A_R \cdot h}{10} + V_{RSt}} \right)}$$

$$f_0 = \frac{\omega_0}{2\pi}$$

$$m_{ölred} = 2 \cdot m_{RK} \left(\frac{1}{d_R} \sqrt{\frac{400 \cdot A_R}{\pi}} \right)^4$$

$$\omega_{01} = \omega_0 \cdot \sqrt{\frac{m_{red}}{m_{ölred} + m_{red}}}$$

$$f_{01} = \frac{\omega_{01}}{2\pi}$$

A_R = Piston ring surface [cm²]

d_K = Piston diameter [mm]

d_{St} = Piston rod diameter [mm]

d_R = NW [mm]

L_K = Length of the piston side [mm]

h = Stroke [mm]

V_R = Volume of the line [cm³]

m_R = Mass of the oil in the line [kg]

f_0 = Intrinsic frequency

ω_0 = Angular frequency

Cylinder Intrinsic Frequency for Plunger Cylinders

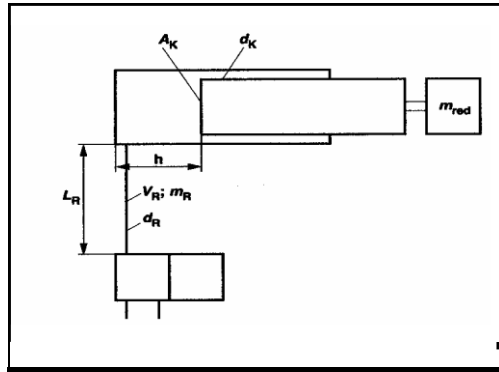

$$A_K = \frac{d_K^2 \pi}{4 \cdot 100}$$

$$V_R = \frac{d_K^2 \pi}{4} \cdot \frac{L_K}{1000}$$

$$m_R = \frac{V_R \cdot \rho_{öl}}{1000}$$

$$\omega_0 = 100 \cdot \sqrt{\frac{E_{öl}}{m_{red}} \cdot \left(\frac{A_K^2}{A_K \cdot h + V_{RSt}} \right)}$$

$$f_0 = \frac{\omega_0}{2\pi}$$

$$m_{öred} = 2 \cdot m_R \left(\frac{d_K}{d_R} \right)^4$$

$$\omega_{01} = \omega_0 \cdot \sqrt{\frac{m_{red}}{m_{öred} + m_{red}}}$$

$$f_{01} = \frac{\omega_{01}}{2\pi}$$

A_K = Piston surface [cm²]

d_K = Piston diameter [mm]

d_R = Diameter of the piping [mm]

L_K = Length piston side [mm]

L_R = Length of the line [mm]

h = Stroke [mm]

V_R = Volume of the line [cm³]

m_R = Mass of the oil in the line [kg]

f_0 = Intrinsic frequency

ω_0 = Angular frequency

Piping

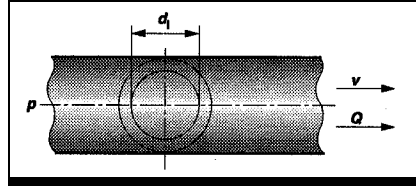

$$\Delta p = \lambda \cdot \frac{l \cdot \rho \cdot v^2 \cdot 10}{d \cdot 2}$$

$$\lambda_{\text{lam.}} = \frac{64}{\text{Re}}$$

$$\lambda_{\text{turb.}} = \frac{0,316}{\sqrt[4]{\text{Re}}}$$

$$\text{Re} = \frac{v \cdot d}{\nu} \cdot 10^3$$

$$v = \frac{Q}{6 \cdot d^2 \cdot \frac{\pi}{4}} \cdot 10^2$$

$$d = \sqrt{\frac{400}{6 \cdot \pi} \cdot \frac{Q}{v}}$$

Δp = Pressure loss at direct piping [bar]

ρ = Density [kg/dm³] (0,89)

λ = Pipe friction coefficient

$\lambda_{\text{lam.}}$ = Pipe friction coefficient for laminar flow

$\lambda_{\text{turb.}}$ = Pipe friction coefficient for turbulent flow

l = Length of the line [m]

v = Velocity in the line [m/s]

d = Internal diameter of the piping [mm]

ν = Kinematic viscosity [mm²/s]

Q = Volume flow in the piping [l/min]

Application Examples for Specification of the Cylinder Pressures and Volume Flows under Positive and Negative Load

Nomenclature

Parameters	Symbols	Units
Acceleration / deceleration	A	m/s ²
Cylinder surface	A ₁	cm ²
Ring surface	A ₂	cm ²
Aspect ratio	$\varphi=A_1/A_2$	-
Total force	F _T	daN
Acceleration force	$F_a=0,1 \cdot m \cdot a$	daN
External forces	F _E	daN
Friction forces (coulomb friction)	F _C	daN
Sealing friction force	F _R	daN
Weight force	G	daN
Mass	$m = \frac{G}{g} + m_K$	kg
Piston mass	m _K	kg
Volume flow	$Q=0,06 \cdot A \cdot v_{max}$ v _{max}	l/min cm/s
Torque	$T=\alpha \cdot J + T_L$	Nm
Load torque	T _L	Nm
Angular acceleration	α	rad/s ²
Inertia moment	J	kgm ²

Differential Cylinder Extending with Positive Load

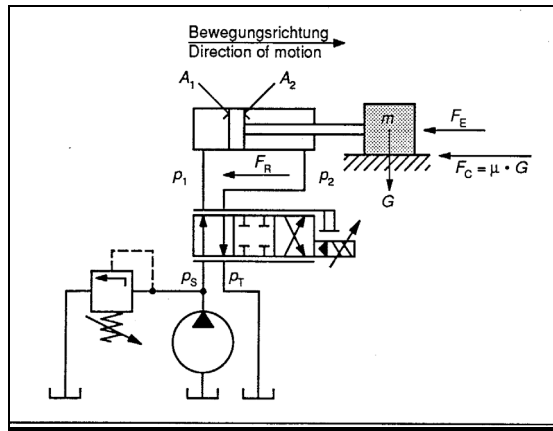

Layout:

$$F_T = F_a + F_R + F_C + F_E \quad [\text{daN}]$$

Given Parameters

- $F_T = 4450 \text{ daN}$
- $P_S = 210 \text{ bar}$
- $P_T = 5,25 \text{ bar}$
- $A_1 = 53,50 \text{ cm}^2$
- $A_2 = 38,10 \text{ cm}^2$
- $\varphi = 1,40$
- $v_{\text{max}} = 30,00 \text{ cm/s}$
- $\implies p_1 \text{ und } p_2$

$$p_1 = \frac{p_S A_2 + R^2 [F_T + (p_T A_2)]}{A_2 (1 + \varphi^3)} \text{ bar}$$

$$p_2 = p_T + \frac{p_S - p_1}{\varphi^2} \text{ bar}$$

Verification of the cylinder dimensioning and calculation of the nominal volume flow Q_N , depending on the load pressure p_1 .

$$Q = 0,06 \cdot A_1 \cdot v_{\text{max}} \quad \text{l/min}$$

$$Q_N = Q \sqrt{\frac{35}{p_S - p_1}} \quad \text{l/min}$$

Selection of a Servo valve 10% larger than the calculated nominal volume flow.

Calculation:

$$p_1 = \frac{210 \cdot 38,1 + 1,4^2 [4450 + (5,25 \cdot 38,1)]}{38,1(1 + 1,4^3)} = 120 \text{ bar}$$

$$p_2 = 5,25 + \frac{210 - 120}{1,4^2} = 52 \text{ bar}$$

$$Q = 0,06 \cdot 53,5 \cdot 30 = 96 \text{ l/min}$$

$$Q_N = 96 \sqrt{\frac{35}{210 - 120}} = 60 \text{ l/min}$$

Differential Cylinder Retracting with Positive Load

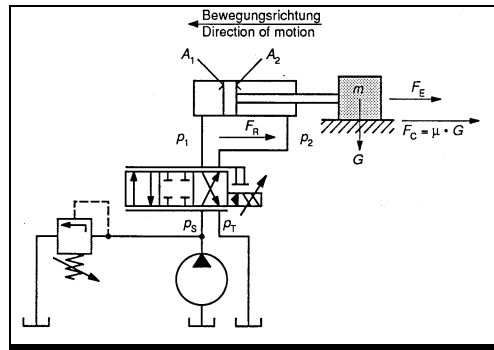

<p>Layout:</p>	<p>Calculation:</p>
<p>$F_T = F_a + F_R + F_C + F_E$ [daN]</p>	<p>$p_2 = \frac{(210 \cdot 38,1 \cdot 1,4^2) + 4450 + (5,25 \cdot 38,1 \cdot 1,4)}{38,1(1 + 1,4^3)} = 187 \text{ bar}$</p>
<p>Given Parameters</p>	<p>$p_1 = 5,25 + [(210 - 187)1,4^2] = 52 \text{ bar}$</p>
<p>$F_T = 4450 \text{ daN}$</p>	<p>$Q = 0,06 \cdot 38,1 \cdot 30 = 69 \text{ l/min}$</p>
<p>$P_S = 210 \text{ bar}$</p>	<p>$Q_N = 96 \sqrt{\frac{35}{210 - 187}} = 841 \text{ l/min}$</p>
<p>$P_T = 5,25 \text{ bar}$</p>	
<p>$A_1 = 53,50 \text{ cm}^2$</p>	
<p>$A_2 = 38,10 \text{ cm}^2$</p>	
<p>$\varphi = 1,40$</p>	
<p>$v_{\max} = 30,00 \text{ cm/s}$</p>	
<p>$\Rightarrow p_1 \text{ und } p_2$</p>	
<p>$p_2 = \frac{(p_S A_2 \varphi^3) + F_T + (p_T A_2 \varphi)}{A_2(1 + \varphi^3)} \text{ bar}$</p>	
<p>$p_1 = p_T + [(p_S - p_2)\varphi^2] \text{ bar}$</p>	
<p>Verification of the cylinder dimensioning and calculation of the nominal volume flow Q_N, depending on the load pressure p_1.</p>	
<p>$Q = 0,06 \cdot A_2 \cdot v_{\max} \text{ l/min}$</p>	
<p>$Q_N = Q \sqrt{\frac{35}{p_S - p_2}} \text{ l/min}$</p>	
<p>Selection of a Servo valve 10% larger than the calculated nominal volume flow.</p>	

Differential Cylinder Extending with Negative Load

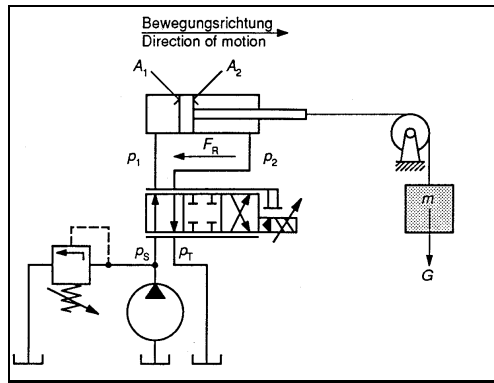

Layout:

$$F_T = F_a + F_R - G \quad [\text{daN}]$$

Given Parameters

$$F_T = -2225 \text{ daN}$$

$$P_S = 175 \text{ bar}$$

$$P_T = 0 \text{ bar}$$

$$A_1 = 81,3 \text{ cm}^2$$

$$A_2 = 61,3 \text{ cm}^2$$

$$\varphi = 1,3$$

$$v_{\text{max}} = 12,7 \text{ cm/s}$$

$$\Rightarrow p_1 \text{ und } p_2$$

$$p_1 = \frac{p_S A_2 + \varphi^2 [F_T + (p_T A_2)]}{A_2 (1 + \varphi^3)} \text{ bar}$$

$$p_2 = p_T + \frac{p_S - p_1}{\varphi^2} \text{ bar}$$

Verification of the cylinder dimensioning and calculation of the nominal volume flow Q_N , depending on the load pressure p_1 .

$$Q = 0,06 \cdot A_1 \cdot v_{\text{max}} \quad \text{l/min}$$

$$Q_N = Q \sqrt{\frac{35}{p_S - p_1}} \quad \text{l/min}$$

Selection of a Servo valve 10% larger than the calculated nominal volume flow.

Calculation:

$$p_1 = \frac{175 \cdot 61,3 + 1,3^2 [-2225 + (0 \cdot 61,3)]}{61,3(1 + 1,3^3)} = 36 \text{ bar}$$

$$p_2 = 0 + \frac{175 - 36}{1,3^2} = 82 \text{ bar}$$

$$Q = 0,06 \cdot 81,3 \cdot 12,7 = 62 \text{ l/min}$$

$$Q_N = 62 \sqrt{\frac{35}{175 - 36}} = 31 \text{ l/min}$$

Differential Cylinder Retracting with Negative Load

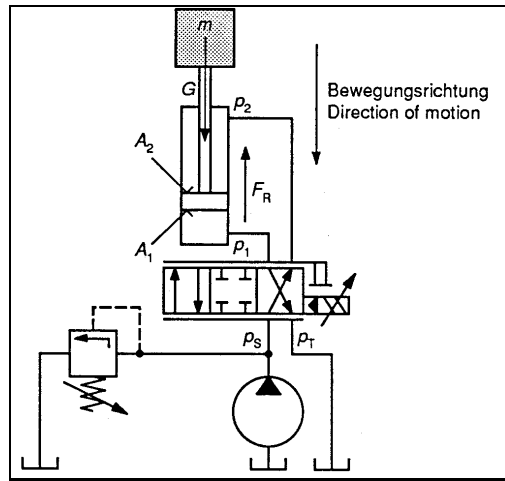

Layout:

$$F_T = F_a + F_R - G \quad [\text{daN}]$$

Given Parameters

$$F_T = -4450 \text{ daN}$$

$$P_S = 210 \text{ bar}$$

$$P_T = 0 \text{ bar}$$

$$A_1 = 81,3 \text{ cm}^2$$

$$A_2 = 61,3 \text{ cm}^2$$

$$\varphi = 1,3$$

$$v_{\text{max}} = 25,4 \text{ cm/s}$$

$$\Rightarrow p_1 \text{ und } p_2$$

$$p_2 = \frac{(p_s A_2 \varphi^3) + F_T + (p_T A_2 \varphi)}{A_2 (1 + \varphi^3)} \text{ bar}$$

$$p_1 = p_T + [(p_s - p_2) \varphi^2] \text{ bar}$$

Verification of the cylinder dimensioning and calculation of the nominal volume flow Q_N , depending on the load pressure p_1 .

$$Q = 0,06 \cdot A_2 \cdot v_{\text{max}} \quad \text{l/min}$$

$$Q_N = Q \sqrt{\frac{35}{p_s - p_2}} \quad \text{l/min}$$

Selection of a Servo valve 10% larger than the calculated nominal volume flow.

Calculation:

$$p_2 = \frac{(210 \cdot 61,3 + 1,3^2) - 4450 + (0 \cdot 61,3 \cdot 1,3)}{61,3(1 + 1,3^3)} = 122 \text{ bar}$$

$$p_1 = 0 + [(210 - 122)] = 149 \text{ bar}$$

$$Q = 0,06 \cdot 61,3 \cdot 25,4 = 93 \text{ l/min}$$

$$Q_N = 93 \sqrt{\frac{35}{210 - 122}} = 591 \text{ l/min}$$

Differential Cylinder Retracting at an Inclined Plane with Positive Load

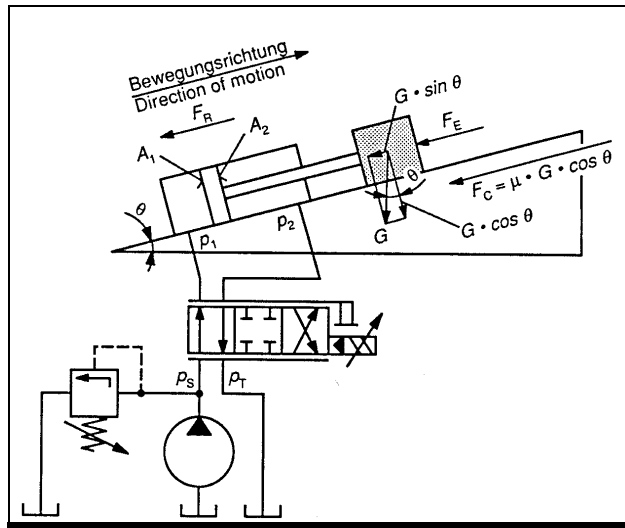

Layout:

$$F_T = F_a + F_E + F_S + [G \cdot (\mu \cdot \cos \alpha + \sin \alpha)] \text{ daN}$$

Given Parameters

$$F_T = 2225 \text{ daN}$$

$$P_S = 140 \text{ bar}$$

$$P_T = 3,5 \text{ bar}$$

$$A_1 = 31,6 \text{ cm}^2$$

$$A_2 = 19,9 \text{ cm}^2$$

$$R = 1,6$$

$$v_{\max} = 12,7 \text{ cm/s}$$

==> p_1 and p_2

$$p_1 = \frac{p_S A_2 + \varphi^2 [F + (p_T A_2)]}{A_2 (1 + \varphi^3)} \text{ bar}$$

$$p_2 = p_T + \frac{p_S - p_1}{\varphi^2} \text{ bar}$$

Verification of the cylinder dimensioning and calculation of the nominal volume flow Q_N , depending on the load pressure p_1 .

$$Q = 0,06 \cdot A_1 \cdot v_{\max} \text{ l/min}$$

$$Q_N = Q \sqrt{\frac{35}{p_S - p_1}} \text{ l/min}$$

Selection of a Servo valve 10% larger than the calculated nominal volume flow.

Calculation:

$$p_1 = \frac{(140 \cdot 19,9) + 1,6^2 [2225 + (3,5 \cdot 19,9)]}{19,9(1 + 1,6^3)} = 85 \text{ bar}$$

$$p_2 = 35 + \frac{140 - 85}{1,6^2} = 25 \text{ bar}$$

$$Q = 0,06 \cdot 31,6 \cdot 12,7 = 24 \text{ l/min}$$

$$Q_N = 24 \sqrt{\frac{35}{140 - 85}} = 19 \text{ l/min}$$

Differential Cylinder Retracting at an Inclined Plane with Positive Load

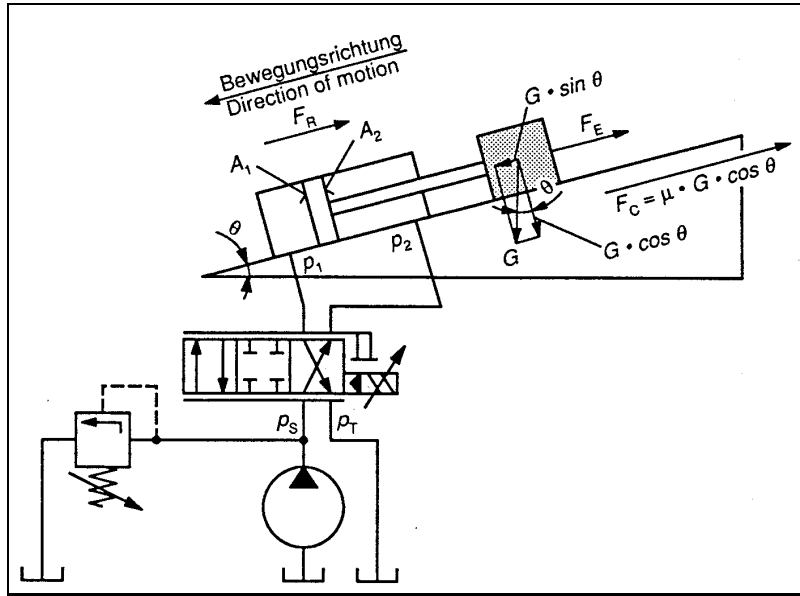

Layout:

$$F_T = F_a + F_E + F_S + [G \cdot (\mu \cdot \cos \alpha + \sin \alpha)] \text{ daN}$$

Given Parameters

$$F_T = 1780 \text{ daN}$$

$$P_S = 140 \text{ bar}$$

$$P_T = 3,5 \text{ bar}$$

$$A_1 = 31,6 \text{ cm}^2$$

$$A_2 = 19,9 \text{ cm}^2$$

$$\varphi = 1,6$$

$$v_{\max} = 12,7 \text{ cm/s}$$

==> p_1 and p_2

$$p_2 = \frac{(p_S A_2 \varphi^3) + F + (p_T A_2 \varphi)}{A_2 (1 + \varphi^3)} \text{ bar}$$

$$p_1 = p_T + [(p_S - p_2) \varphi^2] \text{ bar}$$

Verification of the cylinder dimensioning and calculation of the nominal volume flow Q_N , depending on the load pressure p_1 .

$$Q = 0,06 \cdot A_2 \cdot v_{\max} \text{ l/min}$$

$$Q_N = Q \sqrt{\frac{35}{p_S - p_2}} \text{ l/min}$$

Selection of a Servo valve 10% larger than the calculated nominal volume flow.

Calculation:

$$p_2 = \frac{(140 \cdot 19,9 \cdot 1,6^3) + 1780 + [3,5 \cdot 19,9 \cdot 1,6]}{19,9(1 + 1,6^3)} = 131 \text{ bar}$$

$$p_1 = 3,5 + [(140 - 131) \cdot 1,6^2] = 26 \text{ bar}$$

$$Q = 0,06 \cdot 19,9 \cdot 12,7 = 15 \text{ l/min}$$

$$Q_N = 15 \sqrt{\frac{35}{140 - 131}} = 30 \text{ l/min}$$

Differential Cylinder Extending at an Inclined Plane with Negative Load

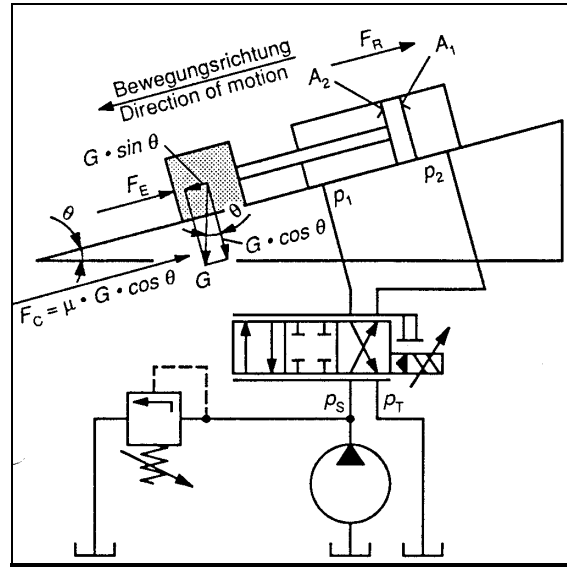

Layout:

$$F_T = F_a + F_E + F_R + [G \cdot (\mu \cdot \cos \alpha - \sin \alpha)] \text{ daN}$$

Given Parameters

$$F_T = -6675 \text{ daN}$$

$$P_S = 210 \text{ bar}$$

$$P_T = 0 \text{ bar}$$

$$A_1 = 53,5 \text{ cm}^2$$

$$A_2 = 38,1 \text{ cm}^2$$

$$\varphi = 1,4$$

$$v_{\max} = 25,4 \text{ cm/s}$$

==> p_1 und p_2

$$p_1 = \frac{p_S A_2 + \varphi^2 [F + (p_T A_2)]}{A_2 (1 + \varphi^3)} \text{ bar}$$

$$p_2 = p_T + \frac{p_S - p_1}{\varphi^2} \text{ bar}$$

Verification of the cylinder dimensioning and calculation of the nominal volume flow Q_N , depending on the load pressure p_1 .

$$Q = 0,06 \cdot A_1 \cdot v_{\max} \text{ l/min}$$

$$Q_N = Q \sqrt{\frac{35}{p_S - p_1}} \text{ l/min}$$

Selection of a Servo valve 10% larger than the calculated nominal volume flow.

Calculation:

$$p_1 = \frac{(210 \cdot 106) + 1,2^2 [-6675 + (0 \cdot 106)]}{106(1 + 1,4^3)} = 131 \text{ bar}$$

Caution!!!

Negative load is leading to cylinder cavitation. Specified parameters to be changed by means of using a larger cylinder size, increasing the system pressure or reducing the necessary total force.

$$A_1 = 126 \text{ cm}^2 \quad A_2 = 106 \text{ cm}^2 \quad R = 1,2$$

$$p_2 = \frac{210 - 44}{1,2^2} = 116 \text{ bar}$$

$$Q = 0,06 \cdot 126 \cdot 25,4 = 192 \text{ l/min}$$

$$Q_N = 192 \sqrt{\frac{35}{210 - 44}} = 88 \text{ l/min}$$

Differential Cylinder Retracting at an Inclined Plane with Negative Load

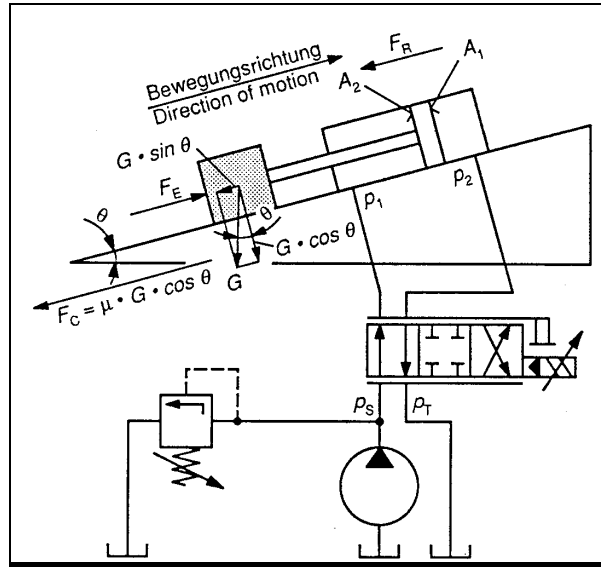

Layout:

$$F = F_a + F_E + F_R + [G \cdot (\mu \cdot \cos \alpha - \sin \alpha)] \text{ daN}$$

Given Parameters

- F = -6675 daN
- PS = 210 bar
- PT = 0 bar
- A1 = 53,5 cm²
- A2 = 38,1 cm²
- φ = 1,4
- v_{max} = 25,4 cm/s
- ==> p₁ and p₂

$$p_2 = \frac{(p_s A_2 \varphi^3) + F + (p_T A_2 \varphi)}{A_2 (1 + \varphi^3)} \text{ bar}$$

$$p_1 = p_T + [(p_s - p_2) \varphi^2] \text{ bar}$$

Verification of the cylinder dimensioning and calculation of the nominal volume flow Q_N, depending on the load pressure p₂.

$$Q = 0,06 \cdot A_2 \cdot v_{\max} \text{ l/min}$$

$$Q_N = Q \sqrt{\frac{35}{p_s - p_2}} \text{ l/min}$$

Selection of a Servo valve 10% larger than the calculated nominal volume flow.

Calculation:

$$p_2 = \frac{(210 \cdot 38,1 \cdot 1,4^3) + [-6675 + (0 \cdot 38,1 \cdot 1,4)]}{38,1(1 + 1,4^3)} = 107 \text{ bar}$$

$$p_1 = 0 + [(210 - 107) \cdot 1,4^2] = 202 \text{ bar}$$

$$Q = 0,06 \cdot 38,1 \cdot 25,4 = 58 \text{ l/min}$$

$$Q_N = 58 \sqrt{\frac{35}{210 - 107}} = 34 \text{ l/min}$$

Hydraulic Motor with a Positive Load

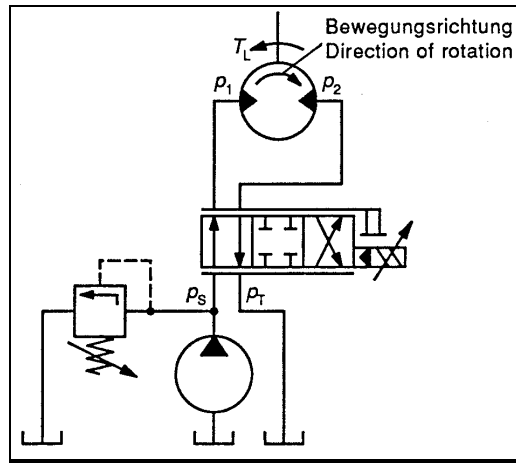

<p>Layout:</p>	<p>Calculation:</p>
<p>$T = \alpha \cdot J + T_L$ [Nm]</p>	<p>$p_1 = \frac{210 + 0}{2} + \frac{10 \cdot \pi \cdot 56,5}{82} = 127 \text{ bar}$</p> <p>$p_2 = 210 - 127 + 0 = 83 \text{ bar}$</p>
<p>Given Parameters</p> <p>$T = 56,5 \text{ Nm}$ $p_s = 210 \text{ bar}$ $p_T = 0 \text{ bar}$ $D_M = 82 \text{ cm}^3/\text{rad}$ $\omega_M = 10 \text{ rad/s}$</p> <p>==> p_1 and p_2</p> <p>$p_1 = \frac{p_s + p_T}{2} + \frac{10\pi T}{D_M} \text{ bar}$</p> <p>$p_2 = p_s - p_1 + p_T \text{ bar}$</p> <p>Verification of the cylinder dimensioning and calculation of the nominal volume flow Q_N, depending on the load pressure p_1.</p>	<p>$Q_M = 0,01 \cdot 10 \cdot 82 = 8,2 \text{ l/min}$</p> <p>$Q_N = 8,2 \cdot \sqrt{\frac{35}{210 - 127}} = 5,3 \text{ l/min}$</p>
<p>$Q_M = 0,01 \cdot \omega_M \cdot D_M \text{ l/min}$</p> <p>$Q_N = Q_M \cdot \sqrt{\frac{35}{p_s - p_1}} \text{ l/min}$</p>	
<p>Selection of a Servo valve 10% larger than the calculated nominal volume flow.</p>	

Hydraulic Motor with a Negative Load

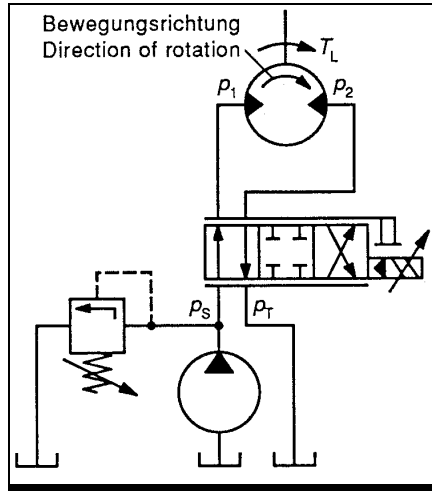

Layout:

$$T = \alpha \cdot J \cdot T_L \quad [\text{Nm}]$$

Given Parameters

$$T = -170 \text{ Nm}$$

$$P_S = 210 \text{ bar}$$

$$P_T = 0 \text{ bar}$$

$$D_M = 82 \text{ cm}^3/\text{rad}$$

$$\omega_M = 10 \text{ rad/s}$$

==> p_1 and p_2

$$p_1 = \frac{p_S + p_T}{2} + \frac{10\pi T}{D_M} \text{ bar}$$

$$p_2 = p_S - p_1 + p_T \text{ bar}$$

Verification of the cylinder dimensioning and calculation of the nominal volume flow Q_N , depending on the load pressure p_1 .

$$Q_M = 0,01 \cdot \omega_M \cdot D_M \quad \text{l/min}$$

$$Q_N = Q_M \sqrt{\frac{35}{p_S - p_1}} \quad \text{l/min}$$

Selection of a Servo valve 10% larger than the calculated nominal volume flow.

Calculation:

$$p_1 = \frac{210 + 0}{2} + \frac{10 \cdot \pi \cdot (-170)}{82} = 40 \text{ bar}$$

$$p_2 = 210 - 40 + 0 = 170 \text{ bar}$$

$$Q_M = 0,01 \cdot 10 \cdot 82 = 8,2 \text{ l/min}$$

$$Q_N = 8,2 \sqrt{\frac{35}{210 - 40}} = 3,6 \text{ l/min}$$

Identification of the Reduced Masses of Different Systems

The different components (cylinder / motors ...) have to be dimensioned for the layout of the necessary forces of a hydraulic system, so that the acceleration and the deceleration of a mass is correct and targeted.

The mechanics of the system are defining the stroke of the cylinders and motors.

Speed- and force calculations have to be carried out.

Statements with view to acceleration and its effects on the system can be made by fixing the reduced mass of a system.

The reduced mass (M) is a concentrated mass, exerting the same force – and acceleration components as the regular mass at the correct system.

The reduced moment of inertia (I_e) has to be considered for rotational systems.

The reduced mass has to be fixed in a first step for considerations with stroke measuring systems or for applications with deceleration of a mass!

Newton's second axiom is used for the specification of the acceleration forces.

$$F = m \cdot a$$

F = force [N]

m = mass [kg]

a = acceleration [m/s^2]

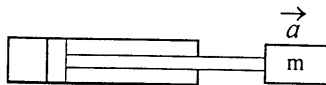

The following equation is applied for rotational movements:

$$\Gamma = I \cdot \theta''$$

Γ = torque [Nm]

I = moment of inertia [kgm^2]

θ'' = angular acceleration [rad/s^2]

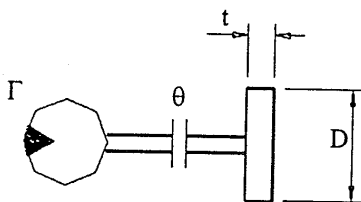

Linear Drives

Primary Applications (Energy Method)

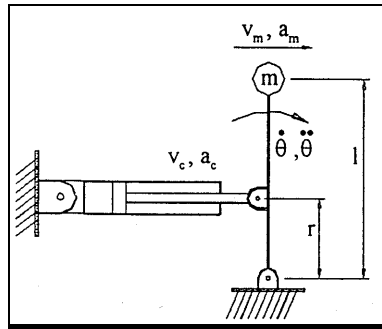

The mass is a concentrated mass and the rod l is weightless. The cylinder axis is positioned rectangular to the rod l .

Relation between cylinder and rod:

$$\theta' = \frac{v_c}{r} = \frac{v_m}{l}$$

$$\theta'' = \frac{a_c}{r} = \frac{a_m}{l}$$

Needed torque for acceleration of the mass:

$$\Gamma = I X \theta'' = F \cdot r$$

$$= m \cdot l^2 X \theta''$$

$$I = m \cdot l^2$$

$$= m \cdot l^2 X \frac{a_m}{l}$$

$$\theta'' = \frac{a_m}{l}$$

$$= m \cdot l X a_m$$

$$\Rightarrow F = \frac{m \cdot l \cdot a_m}{r} = m \cdot i \cdot a_m \quad i = \frac{l}{r}$$

$m \cdot i$ can be considered as mass movement m .

$$F = m \cdot i \cdot a_m = m \cdot i \cdot \frac{l \cdot a_c}{r} = m \cdot i^2 \cdot a_c = M \cdot a_c \quad \text{mit } \frac{a_c}{r} = \frac{a_m}{l}$$

F = cylinder force

M = reduced mass

a_c = acceleration of the cylinder rod

General validity:

$$M = m \cdot i^2$$

The same result can be obtained by the aid of the energy method (kinetic energy of the mass m). The dependence of the mass movement with the cylinder movement can be specified with the help of the geometry of the system.

Energy of the mass:

$$KE = \frac{1}{2} I \cdot \theta'^2 = \frac{1}{2} m \cdot l^2 \cdot \theta'^2 \quad (I = m \cdot l^2)$$

Formulary Hydraulics

$$= \frac{1}{2} m \cdot l^2 \cdot \left(\frac{v_c}{r} \right)^2 \quad (v_c = r \cdot \theta')$$

$$= \frac{1}{2} m \cdot \frac{l^2}{r^2} \cdot v_c^2$$

$$= \frac{1}{2} M \cdot v_c^2 \quad M = m \cdot i^2 \text{ and } i = l/r$$

Concentrated Mass with Linear Movements

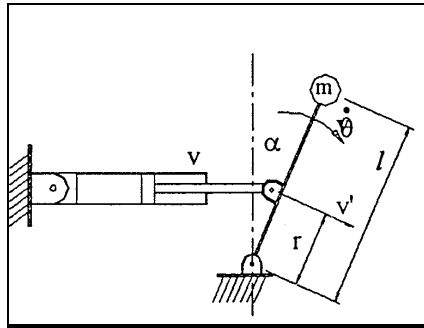

v is the horizontal component of v'. v' is positioned rectangular to rod l.

Energy method:

$$\begin{aligned}
 KE &= \frac{1}{2} I \cdot \theta'^2 = \frac{1}{2} m \cdot l^2 \cdot \theta'^2 \\
 &= \frac{1}{2} m \cdot l^2 \cdot \left(\frac{v'}{r} \right)^2 && (\theta' = v'/r) \\
 &= \frac{1}{2} m \cdot \frac{l^2}{r^2} \cdot v'^2 \\
 &= \frac{1}{2} m \cdot i^2 \cdot v'^2
 \end{aligned}$$

with $v = v' \cdot \cos \alpha$

$$\begin{aligned}
 \Rightarrow KE &= \frac{1}{2} m \cdot i^2 \cdot v'^2 \\
 &= \frac{1}{2} \frac{m \cdot i^2}{(\cos \alpha)^2} \cdot v^2 = \frac{1}{2} M \cdot v^2
 \end{aligned}$$

with $M = m \frac{i^2}{(\cos \alpha)^2} \Rightarrow M$ is position-dependent

If: $\alpha = 0$ then, $\cos \alpha = 1$ and $M = m i^2$
 $\alpha = 90^\circ$ then, $\cos \alpha = 0$ and $M = \infty$

$\alpha = 30^\circ$ then, $\cos \alpha = \pm 0,866$ and $M \alpha = m \frac{i^2}{0,75}$

If a cylinder is moving a mass, as shown in the preceding figure, and the movement is situated between -30° and $+30^\circ$, the acceleration- and deceleration forces have to be calculated in the center of motion with a reduced mass, twice as large as the one in the neutral center.

Distributed Mass at Linear Movements

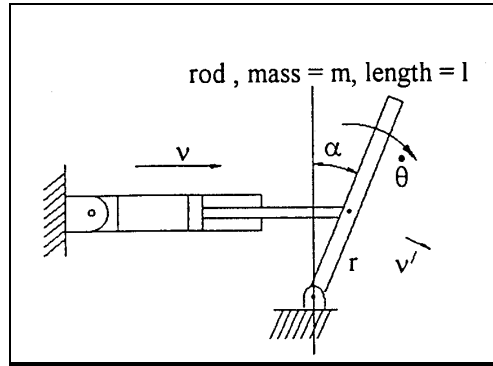

When considering the same rod l with the mass m, you can here also calculate the reduced mass of the rod.

$$KE = \frac{1}{2} I \cdot \theta'^2 = \frac{1}{2} X \cdot \frac{1}{3} m \cdot l^2 \cdot \theta'^2 \quad \frac{1}{3} \cdot m \cdot l^2$$

$$= \frac{1}{2} X \cdot \frac{1}{3} m \cdot l^2 \cdot \left(\frac{v'}{r} \right)^2 \quad (\theta' = v'/r)$$

$$= \frac{1}{2} X \cdot \frac{1}{3} m \cdot \frac{l^2}{r^2} \cdot v'^2$$

$$= \frac{1}{2} X \cdot \frac{1}{3} m \cdot i^2 \cdot v'^2$$

with $v = v' \cdot \cos \alpha$

$$= \frac{1}{2} X \cdot \frac{1}{3} \cdot \frac{m \cdot i^2}{(\cos \alpha)^2} \cdot v^2 = \frac{1}{3} \cdot M \cdot v^2$$

$$M = \frac{1}{2} \cdot \frac{m \cdot i^2}{(\cos \alpha)^2}$$

Rotation

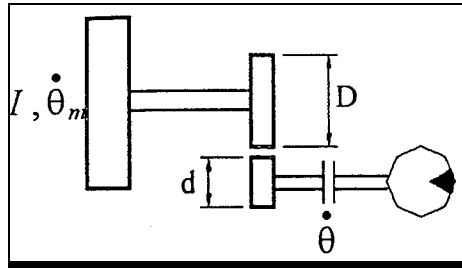

If considering now a rotating mass with a moment of inertia I, driven by a motor (ratio D/d).

$$KE = \frac{1}{2} I \cdot \dot{\theta}'^2_m = \frac{1}{2} I \cdot \left(\dot{\theta}' \cdot \frac{d}{D} \right)^2$$

I = moment of inertia [kgm²]

$$= \frac{1}{2} I \cdot \left(\frac{d}{D} \right)^2 \cdot \dot{\theta}'^2$$

$\dot{\theta}'$ = angular acceleration [rad/s²]

$$= \frac{1}{2} I \cdot i^2 \cdot \dot{\theta}'^2$$

$$= \frac{1}{2} I_e \cdot \dot{\theta}'^2$$

$$I_e = I \cdot i^2$$

$$i = d/D$$

If a gearbox has to be used, i has to be considered.

If $i = D/d$, then $I_e = I/i^2$

Combination of Linear and Rotational Movement

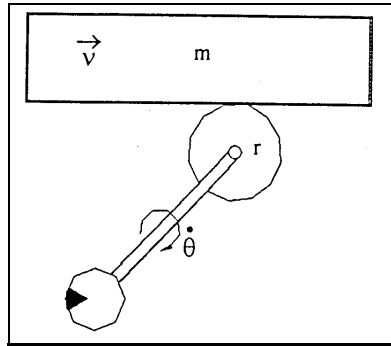

A mass m is here moved by a wheel with radius r . The wheel is weightless.

$$KE = \frac{1}{2} m \cdot v^2$$

$$= \frac{1}{2} m \cdot (r \cdot \theta')^2$$

$$v = r \cdot \theta'$$

$$= \frac{1}{2} m \cdot r^2 \cdot \theta'^2$$

$$= \frac{1}{2} I_e \cdot \theta'^2$$

$$I_e = m \cdot r^2$$

Hydraulic Resistances

The resistance of an area reduction is the change of the applied pressure difference Δp to the corresponding volume flow change.

$$R = \frac{d(\Delta p)}{dQ}$$

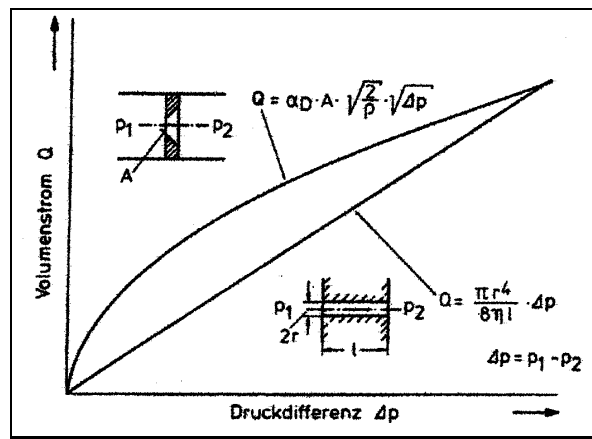

Orifice Equation

$$Q_{Blende} = 0,6 \cdot \alpha_K \cdot \frac{d_B^2 \cdot \pi}{4} \cdot \sqrt{\frac{2 \cdot \Delta p}{\rho}}$$

α_K = flow coefficient (0,6-0,8)

ρ = 0,88 [kg/dm³]

d_B = orifice diameter [mm]

Δp = pressure difference [bar]

$Q_{orifice}$ = [l/min]

Throttle Equation

$$Q_{Drossel} = \frac{\pi \cdot r^4}{8 \cdot \eta \cdot l} \cdot (p_1 - p_2)$$

$\eta = \rho \cdot \nu$

$Q_{throttle}$ = [m³/s]

η = dynamic viscosity [kg/ms]

l = throttle length [m]

r = radius [m]

ν = kinematic viscosity [m²/s]

ρ = 880 [kg/m³]

Hydro Accumulator

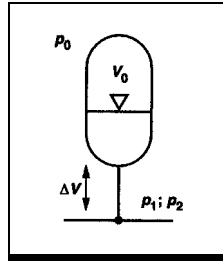

$$\Delta V = V_0 \left(\frac{p_0}{p_1} \right)^{\frac{1}{\kappa}} \cdot \left[1 - \left(\frac{p_1}{p_2} \right)^{\frac{1}{\kappa}} \right]$$

$$p_2 = \frac{p_1}{\left[1 - \frac{\Delta V}{V_0 \left(\frac{p_0}{p_1} \right)^{\frac{1}{\kappa}}} \right]^{\kappa}}$$

$$V_0 = \frac{\Delta V}{\left(\frac{p_0}{p_1} \right)^{\frac{1}{\kappa}} \cdot \left[1 - \left(\frac{p_1}{p_2} \right)^{\frac{1}{\kappa}} \right]}$$

$\kappa = 1,4$ (adiabatic compression)

ΔV = effective volume [l]

V_0 = accumulator size [l]

p_0 = gas filling pressure [bar]

p_1 = service pressure min [bar] (pressure loss at the valve)

p_2 = service pressure max [bar]

$p_0 = <0,9 \cdot p_1$

Provide an accumulator in the pressure circuit for pressure-controlled pumps!

Swivel time of pump t_{SA} of the pump catalog.

$$\Delta V = Q \cdot t_{SA}$$

Heat Exchanger (Oil - Water)

$$ETD = t_{\text{öl}} - t_{\text{K}}$$

$$p_{01} = \frac{P_{\text{V}}}{ETD}$$

$$\Delta t_{\text{K}} = \frac{14 \cdot P_{\text{V}}}{V_{\text{K}}}$$

Calculation of $\Delta t_{\text{öl}}$ is different, depending on the respective hydraulic fluid.

$V_{\text{öl}}$ = oil flow [l/min]

P_{V} = dissipation power [kW]

$t_{\text{öl}}$ = inlet temperature oil [°C]

$\Delta t_{\text{öl}}$ = cooling of the oil [K]

t_{K} = inlet temperature cooling water [°C]

Δt_{K} = heating of the cooling water [K]

V_{K} = cooling water flow [l/min]

ETD = inlet temperature difference [K]

p_{01} = spec. cooling capacity [kW/h]

HFA	HLP/HFD	HFC
$\Delta t_{\text{öl}} = \frac{14,7 \cdot P_{\text{V}}}{V_{\text{öl}}}$	$\Delta t_{\text{öl}} = \frac{36 \cdot P_{\text{V}}}{V_{\text{öl}}}$	$\Delta t_{\text{öl}} = \frac{17,2 \cdot P_{\text{V}}}{V_{\text{öl}}}$

The size of the heat exchangers can be defined by the calculated value p_{01} of the diagrams of the different manufacturers.

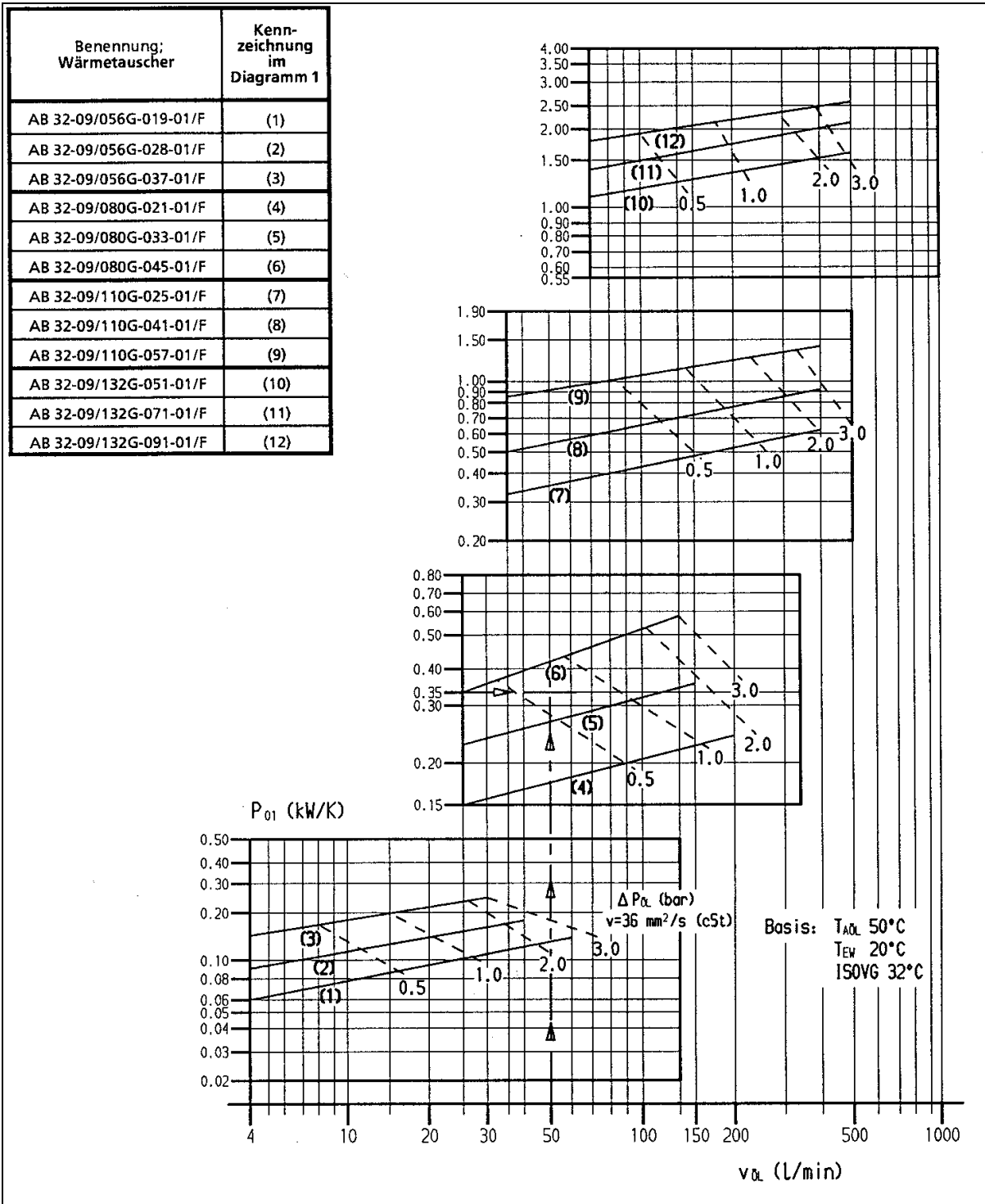

Layout of a Valve

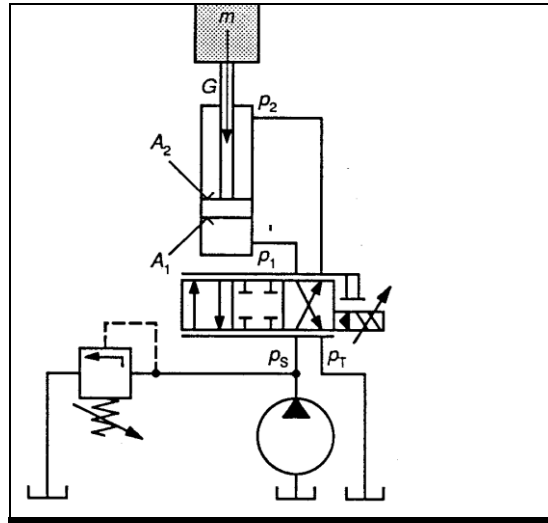

The necessary volume flow can be calculated based on the cylinder data as well as on the extending – and retracting speeds.

P = Ps system pr. - PL load pr. - P T return pressure
(Load pressure $\approx \frac{2}{3}$ * System pressure)
At optimal efficiency

F_T = load force [daN]
 P_S = system pressure [bar]
 P_T = return pressure [bar]
 A_1 = piston surface cm²
 A_2 = ring surface cm²
 φ = aspect ratio cylinder
 v_{max} = extending speed of the cylinder cm/s

→ p_1 and p_2

$$p_2 = \frac{(p_s A_2 \varphi^3) + F_T + (p_T A_2 \varphi)}{A_2 (1 + \varphi^3)} \text{ bar}$$

$$p_1 = p_T + [(p_s - p_2) \varphi^2] \text{ bar}$$

Verification of the cylinder dimensioning and calculation of the nominal volume flow Q_N , depending on the load pressure p_1 .

$$Q = 0,06 \cdot A_2 \cdot v_{max} \text{ l/min}$$

$$Q_N = Q \sqrt{\frac{X}{p_s - p_2}} \text{ l/min}$$

$X = 35$ (Servo valve) pressure loss via a leading edge
 $X = 35$ (Prop valve) pressure loss via a leading edge
 (Prop valve with shell)

$X = 5$ (Prop valve) pressure loss via a leading edge
 (Prop valve without shell)

Selection of a valve 10% larger than the calculated nominal volume flow