

Standard Runner Blocks, Steel Version

Runner Block FKS R1665

Flanged Short Standard

Versions:

- Runner block without ball chain:
See table for part numbers
- Runner block with low friction seal without ball chain:
Part numbers R1665 xxx 21
- Runner block with ball chain:
Part numbers R1665 xxx 22
- Runner block with low friction seal and ball chain:
Part numbers R1665 xxx 23

Dynamic Characteristics

Speed $v_{\max} = 5 \text{ m/s}$

Acceleration $a_{\max} = 500 \text{ m/s}^2$

Precision Runner Block

- Pre-lubricated

Corrosion resistant Version Resist NR* R2000

- Pre-lubricated

Resist NR with corrosion-resistant steel runner block housing

Resist NR without ball chain, see Table

Resist NR with low friction seal, without ball chain R2000 xxx 31

Resist NR with ball chain 2000 xxx 32

Resist NR with low friction seal and ball chain R2000 xxx 33

* In Preparation

Custom version

Chrome-plated Resist CR

- Pre-lubricated

Resist CR – Chromium-plated matt silver runner block housing instead of corrosion-resistant steel runner block housing

Resist CR without ball chain R1665 xxx 70

Resist CR with low friction seal, without ball chain R1665 xxx 71

Resist CR with ball chain R1665 xxx 72

Resist CR with low friction seal and ball chain R1665 xxx 73

Preload Class

C0 = without Preload

C1 = Preload 2% C

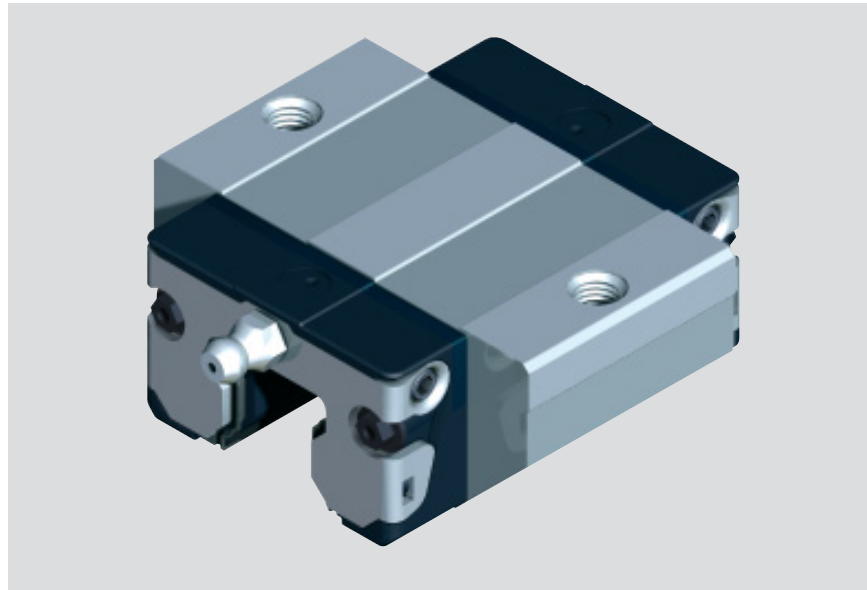

Size	Accuracy Class	Part numbers for runner blocks for preload class	
		C0	C1
15	N	R1665 194 20	R1665 114 20
	H	R1665 193 20	R1665 113 20
20	N	R1665 894 20	R1665 814 20
	H	R1665 893 20	R1665 813 20
25	N	R1665 294 20	R1665 214 20
	H	R1665 293 20	R1665 213 20
30	N	R1665 794 20	R1665 714 20
	H	R1665 793 20	R1665 713 20
35	N	R1665 394 20	R1665 314 20
	H	R1665 393 20	R1665 313 20

Size	Accuracy Class	Part numbers for runner blocks for preload class	
		C0	C1
15	H	R2000 193 30	
20	H	R2000 893 30	
25	H	R2000 293 30	
30	H	R2000 793 30	R2000 713 30
35	H	R2000 393 30	R2000 313 30

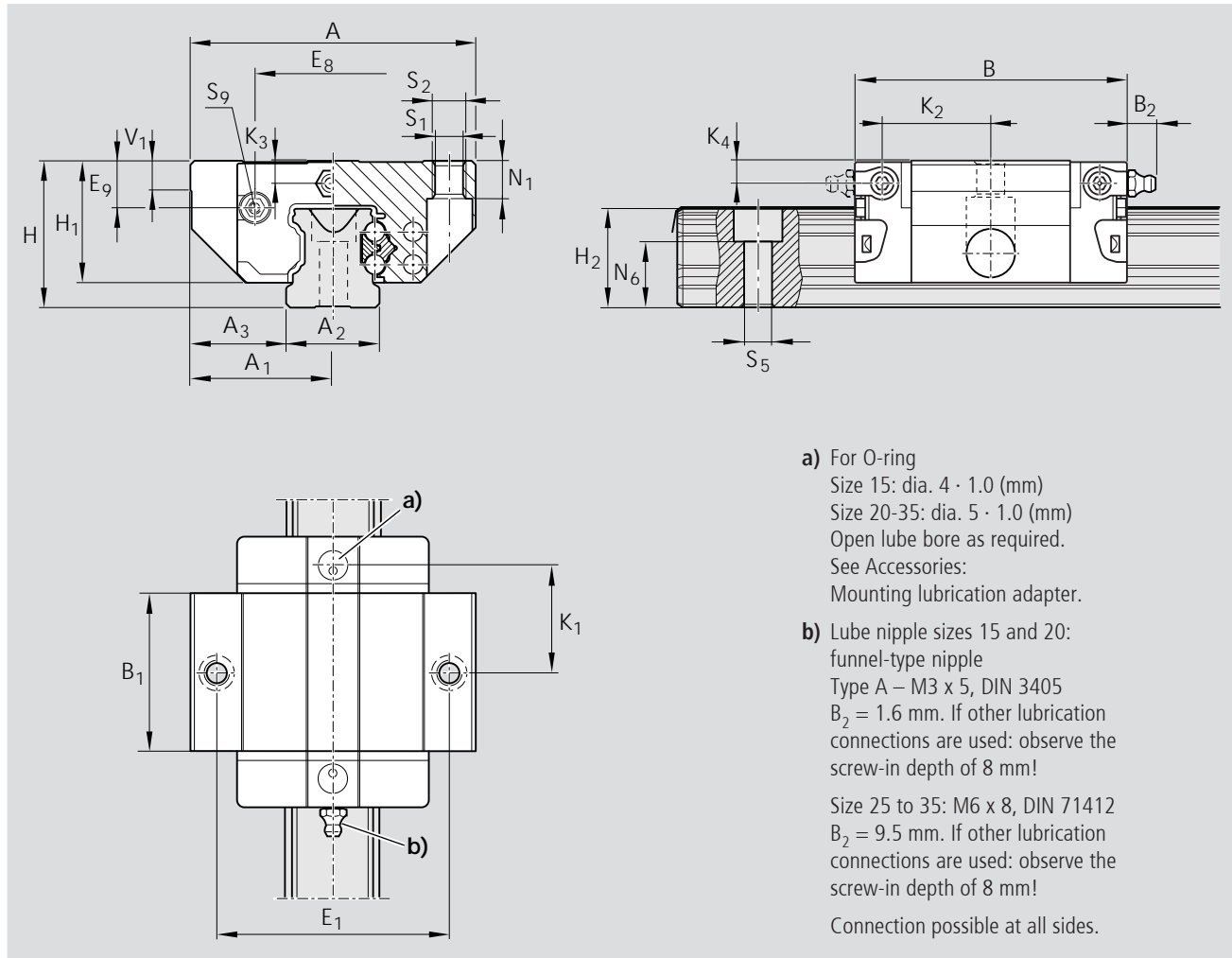

- a) For O-ring
 Size 15: dia. 4 · 1.0 (mm)
 Size 20-35: dia. 5 · 1.0 (mm)
 Open lube bore as required.
 See Accessories:
 Mounting lubrication adapter.
- b) Lube nipple sizes 15 and 20:
 funnel-type nipple
 Type A – M3 x 5, DIN 3405
 B₂ = 1.6 mm. If other lubrication connections are used: observe the screw-in depth of 8 mm!
 Size 25 to 35: M6 x 8, DIN 71412
 B₂ = 9.5 mm. If other lubrication connections are used: observe the screw-in depth of 8 mm!
 Connection possible at all sides.

Size	Dimensions (mm)																	
	A	A ₁	A ₂	A ₃	B	B ₁	H	H ₁	H ₂ ¹⁾	H ₂ ²⁾	V ₁	E ₁	E ₈	E ₉	K ₁	K ₂	K ₃	K ₄
15	47	23.5	15	16.0	44.7	25.7	24	19.90	16.30	16.20	5.0	38	24.55	6.70	16.25	17.85	3.20	3.20
20	63	31.5	20	21.5	57.3	31.9	30	25.35	20.75	20.55	6.0	53	32.50	7.30	22.95	22.95	3.35	3.35
25	70	35.0	23	23.5	67.0	38.6	36	29.90	24.45	24.25	7.5	57	38.30	11.50	25.35	26.50	5.50	5.50
30	90	45.0	28	31.0	75.3	45.0	42	35.35	28.55	28.35	7.0	72	48.40	14.60	28.80	30.50	6.05	6.05
35	100	50.0	34	33.0	84.9	51.4	48	40.40	32.15	31.85	8.0	82	58.00	17.35	32.70	34.20	6.90	6.90

¹⁾ Dimension H₂ with rail seal cover strip

²⁾ Dimension H₂ without rail seal cover strip

Size	Dimensions (mm)							Mass (kg)	Load capacities (N) ³⁾				Moments (Nm)			
	N ₁	N ₆ ^{±0.5}	S ₁	S ₂	S ₅	S ₉	C		M _t		M _L		M _{L0}			
							dyn.		stat.	dyn.	stat.	dyn.	stat.	dyn.	stat.	
15	5.2	10.0	4.3	M5	4.4	M2.5-3.5 deep	0.15	5 400	8 100	52	80	19	28			
20	7.7	13.2	5.3	M6	6.0	M3-5 deep	0.30	12 400	13 600	150	170	52	58			
25	9.3	15.2	6.7	M8	7.0	M3-5 deep	0.50	15 800	18 200	230	260	82	94			
30	11.0	17.0	8.5	M10	9.0	M3-5 deep	1.80	22 100	24 800	380	430	133	150			
35	12.0	20.5	8.5	M10	9.0	M3-5 deep	1.20	29 300	32 400	640	700	200	220			

³⁾ Load capacities for version without ball chain. Load capacities for version with ball chain, see Product Overview with Load Capacities.

Determination of the dynamic of the load capacities and moments is based on 100,000 m of stroke travel. Often only 50,000 m are actually stipulated. Comparison: Value C, M_t und M_L per table multiplied by 1.26.