

**MANNESMANN  
REXROTH**

**Electronic Amplifiers**  
for the control of up to 6 proportional axes  
Types MHVA 6 B to Types MHVA 12 B, Series 1X

**RE**  
**29 883/07.97**  
Replaces: 12.94

The electronic amplifiers MHVA 6 B to Types MHVA 12 B are suitable for the control of 3 to 6 proportional axes (2 solenoids each).

**Characteristics:**

- According to type 6 to 12 pulsed output stages for proportional solenoids
- Output stages may be switched off individually for axes 1 and 2; for axes 3 to 6 in pairs
- Voltage supply for external command value potentiometers (+ 7,0 V)
- 3 to 6 differential amplifier inputs  $\pm 10$  V
- 3 to 6 additional inputs ( $M0 \pm 3,5$  V)
- Step function generator
- Adjustable time ramp (via trimming potentiometer)
- Potentiometer for setting of  $I_{10\%}$  and  $I_{max}$  per solenoid
- Limited short circuit protection and overload protection
- Polarity safeguard

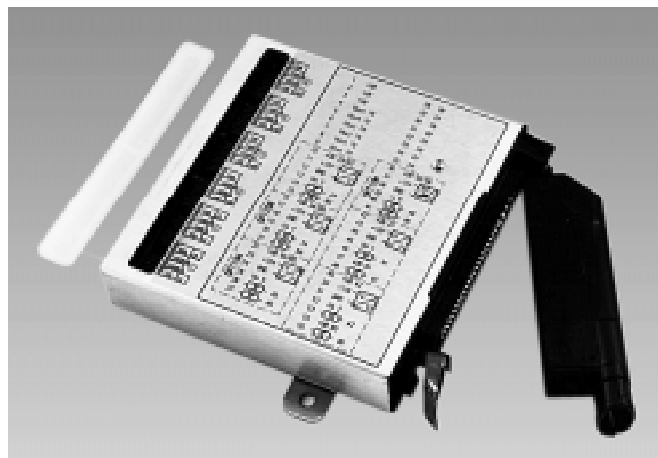

H/A 4438/94  
MHVA 6 B1X

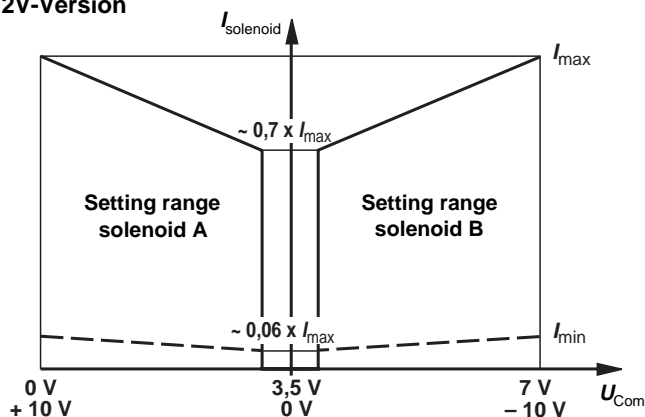
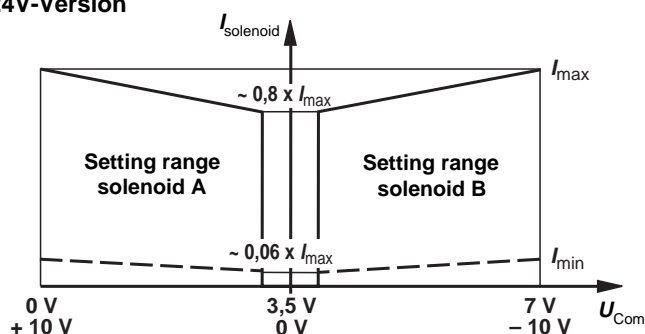
**Output curves****Common control of solenoid A and B****12V-Version****24V-Version****Technical Data****Operating voltage:**

- 12V-Version  $U_{eff}$ : 10,5 V to 16 V
- 24V-Version  $U_{eff}$ : 21,5 V to 32 V

**Command supply voltage**

- $U_{ext}$ : + 7,0 V (max. 15 mA)
- $M0_{ext}$ : + 3,5 V (max. 2,5 mA)

**Valve type:**

FTDRE2K, DRE4K or direct operated solenoid

**Pulse frequency**

$f$ : approx. 150 to 230 Hz (according to valve type)

**Power consumption**

Amplifier without solenoid:

- 12V-Version  $P_{max}$ : appr. 1 W ( $I_{max} \approx 90$  mA)
- 24V-Version  $P_{max}$ : appr. 2 W ( $I_{max} \approx 90$  mA)

**Output current (dependent on valve type)**

- 12V-Version  $I_{max}$ : 2,6 A (continuous)
- 24V-Version  $I_{max}$ : 1,8 A (continuous)
- $I_{ges}$ :  $\leq 10$  A

**Command voltage range**

$U_{Soll}$ : 0 to  $\pm 10$  V ( $M0 \pm 3,5$  V)

**Max. constant pulse control**

$U_{max}$ :  $\pm 3$  V

**Input resistance of the differential amplifier**

$R_E$ : approx. 10 k $\Omega$

**Fuse**

$I_S$ : max. 10 A T

**Type of connection:**

55-pin AMP-plug

**Contact material:**

CuZn

**Plug-in cycles:**

max. 10

**Perm. ambient temperature range  $\vartheta$ :**

- 25 to + 70  $^{\circ}$ C

**Storage temperature range  $\vartheta$ :**

- 30 to + 80  $^{\circ}$ C

**Insulation to DIN 40 050:**

IP 30

**Weight**

$m$ : approx. 0,85 kg

For application outside these parameters please consult us!

# Block Circuit Diagram / Terminal Connection

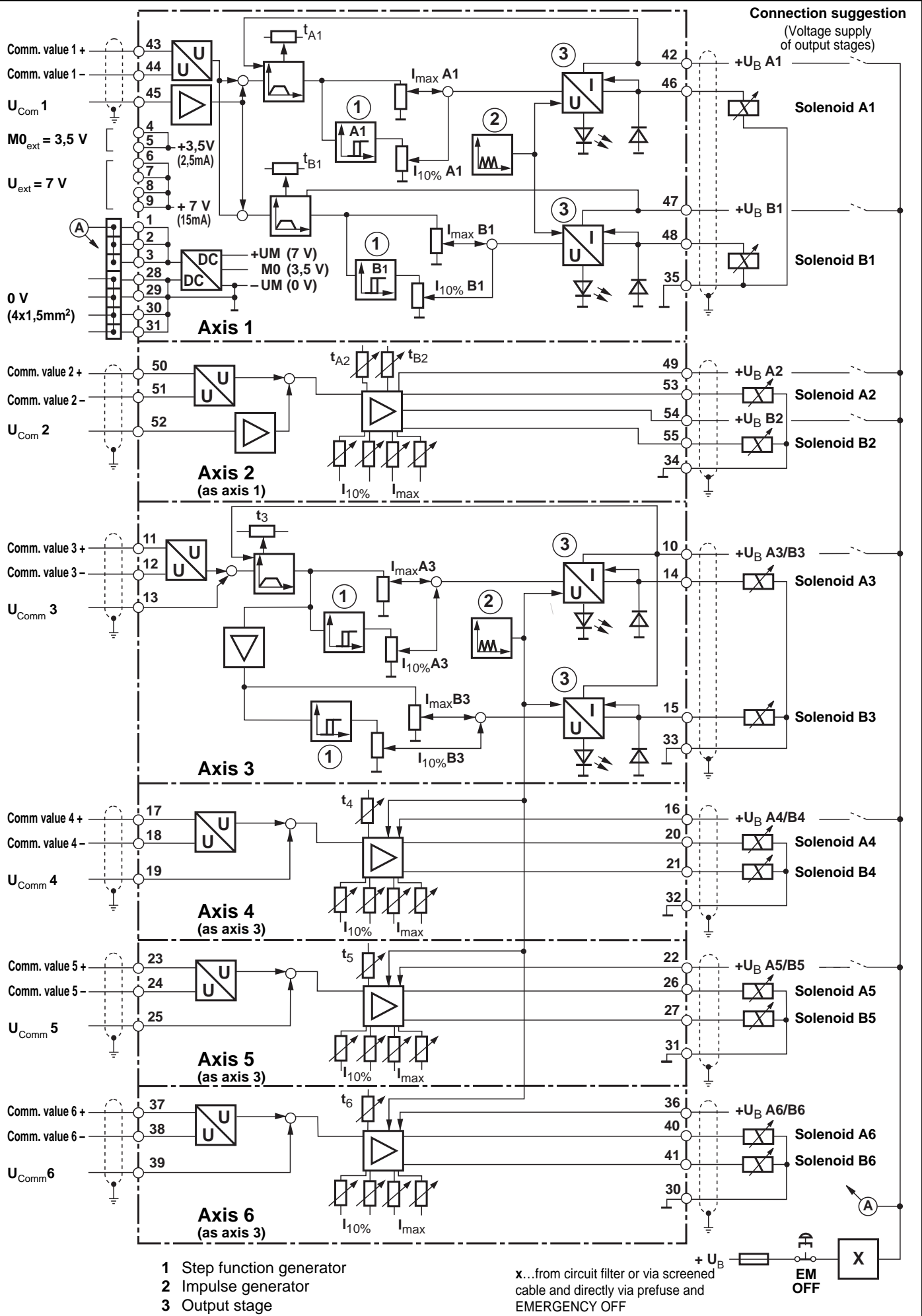

## Function Description

The amplifiers are suitable for wall mounting. Their electric connection is via a 55-pin AMP-plug.

The amplifier outputs for the proportional solenoids A and B are activated by connecting approx. 10% of the maximum command voltage at either the differential amplifier input or at the additional input. A positive command value voltage at the differential inputs controls the solenoid A and a negative voltage controls the solenoid B. The inputs and outputs of the command value potentiometer are connected to the pins 6 to 9 and 28 to 31 where the internal amplifier voltage of 7.0 V is supplied.

When connecting 10% of the maximum command voltage to the differential input the output current increases jump-like. The height of the 10% jump can be set separately externally via a potentiometer for each axis and for the proportional outputs A and B. With the increase of the command voltage the solenoid current of the proportional output in question increases linearly.

The maximum current can also be set externally via a trimming potentiometer separately for outputs A and B. Therefore the increase of the output curve is influenced by this.

LEDs indicate the current output for each proportional output whereby the brightness of the LEDs is approximately proportional to the solenoid current of A and B.

The output stages for axes 1 and 2 can be released or blocked individually via the supply voltage and for axes 3 to 6 in pairs.

A time ramp function is included in the amplifier which may be externally changed by means of a trimming potentiometer. The setting range of the ramp times is from 50 ms up to approx. 3 s.

## Setting Elements

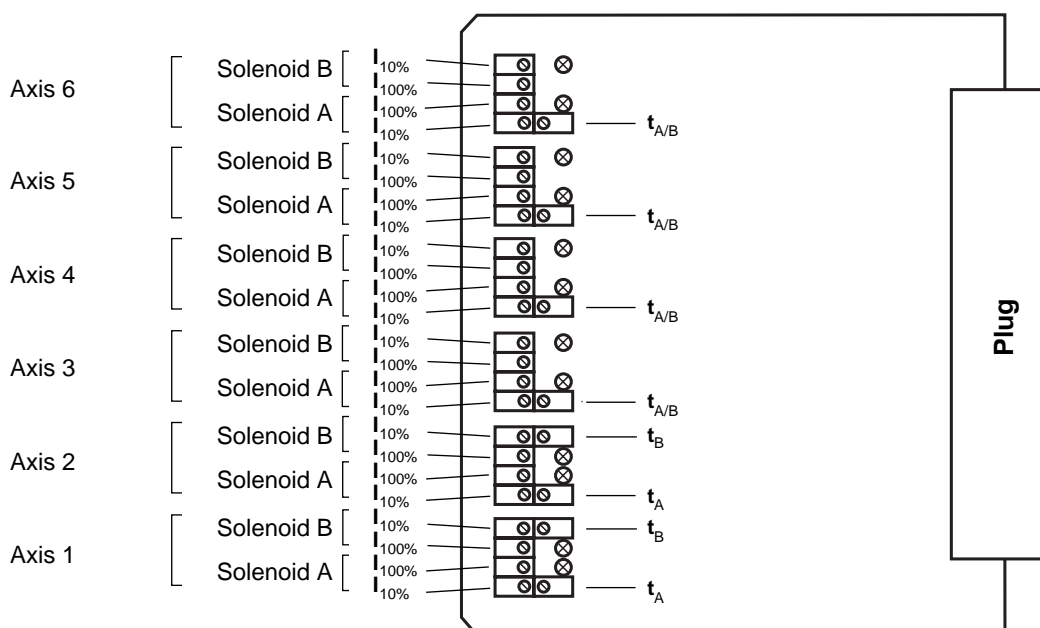

### Meaning of potentiometer

- $t_A$ : Ramp for solenoid A (current increase and decrease)  
Direction of rotation clockwise → Extension of ramp time
- $t_B$ : Ramp time for solenoid B (current increase and decrease)  
Direction of rotation clockwise → Extension of ramp time
- $t_{A/B}$ : Ramp time for solenoids A and B (current increase and decrease)  
Direction of rotation clockwise → Extension of ramp time
- $I_{100\%}$ : Current with 100%-command value  
Direction of rotation clockwise → Current increase
- $I_{10\%}$ : Current jump at 10%-command value  
Direction of rotation clockwise → Current increase

## Plug Connection

<b>Pin-No.:</b> 1	+ U <sub>B</sub> Amplifier	<b>Pin-No.:</b> 28	GND	
2	+ U <sub>B</sub> Amplifier	29	GND	
3	+ U <sub>B</sub> Amplifier	30	GND	
4	M0 <sub>ext</sub> = + 3,5 V	31	GND	
5	M0 <sub>ext</sub> = + 3,5 V	32	GND	
6	U <sub>ext</sub> = + 7 V	33	GND	
7	U <sub>ext</sub> = + 7 V	34	GND	
8	U <sub>ext</sub> = + 7 V	35	GND	
9	U <sub>ext</sub> = + 7 V	36	+ U <sub>B</sub> solenoids A6 and B6	] Axis 6
10	+ U <sub>B</sub> solenoids A3 and B3	37	Command value +	
11	Command value +	38	Command value –	
12	Command value –	39	U <sub>Comm</sub> 6	] Axis 1
13	U <sub>Comm</sub> 3	40	Output solenoid A6 +	
14	Output solenoid A3 +	41	Output solenoid B6 +	
15	Output solenoid B3 +	42	+ U <sub>B</sub> solenoid A1	] Axis 2
16	+ U <sub>B</sub> solenoids A4 and B4	43	Command value +	
17	Command value +	44	Command value –	
18	Command value –	45	U <sub>Comm</sub> 1	] Axis 3
19	U <sub>Comm</sub> 4	46	Output solenoid A1 +	
20	Output solenoid A4 +	47	+ U <sub>B</sub> solenoid B1	
21	Output solenoid B4 +	48	Output solenoid B1 +	] Axis 4
22	+ U <sub>B</sub> solenoids A5 and B5	49	+ U <sub>B</sub> solenoid A2	
23	Command value +	50	Command value +	
24	Command value –	51	Command value –	] Axis 5
25	U <sub>Comm</sub> 5	52	U <sub>Comm</sub> 2	
26	Output solenoid A5 +	53	Output solenoid A2 +	
27	Output solenoid B5 +	54	+ U <sub>B</sub> solenoid B2	] Axis 6
		55	Output solenoid B2 +	

## Project /Maintenance Instructions

- The amplifier may only be connected when switched off!
- Ensure adequate distance to radio sources!
- The amplifier is to be connected in such a way that the plug connection points downwards!
- The cable connection must be stress-relieved and connected in such a way that no friction corrosion at the plug contacts can occur due to vibration! The contacts must be protected from corrosion !
- Do not lay lines near power lines!
- When connecting several solenoids several ground lines (GND lines) must also be connected!
- Do not use free wheel diodes in the solenoid lines! When separating the solenoid lines (e.g. with a relay) adequate protective switches are necessary!
- Caution with time ramp operation! When the electronics are switched off the time ramp is unable to continue!
- In case of emergency or fault the operating voltage of the amplifier and of the output stages must be switched off externally!
- If a solenoid output (short circuit) is overloaded the output concerned is disconnected. This undesirable state must be rectified immediately! The reconnection of the solenoid output can only be carried out with a command value of 0 V.
- During electric welding works near the amplifier the connection plug must be separated from the amplifier!
- To avoid overloading the sum of the appropriate input signals during the simultaneous connection of several inputs per channel must not be more than 100% command value!
- When the unit is faulty malfunctions must be taken into consideration (unvoluntary control or switching off of one or several solenoids)!
- All connection lines must be screened: the screen must be connected to ground at the amplifier! The housing must also be connected to ground! The connection as well as the installation of the amplifier is to be carried out HF-screened!
- We do not accept system responsibility with this component!

## Notes for fault diagnosis

### Overloading of an output:

- The output stage concerned switches off automatically, the activation LED switches off.

### Cable break in the lines of an proportional solenoid:

- The activation LED for the proportional output is permanently illuminated with full intensity.

## Connection Command value generator

With supply of command value potentiometers with external voltage ( $U_{ext} \sim 7\text{ V}$ )

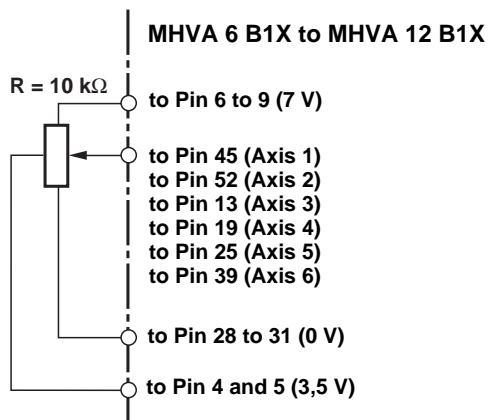

**Note:** When cable break occurs full control of a solenoid can be carried out!

With external command value of  $\pm 10\text{ V}$

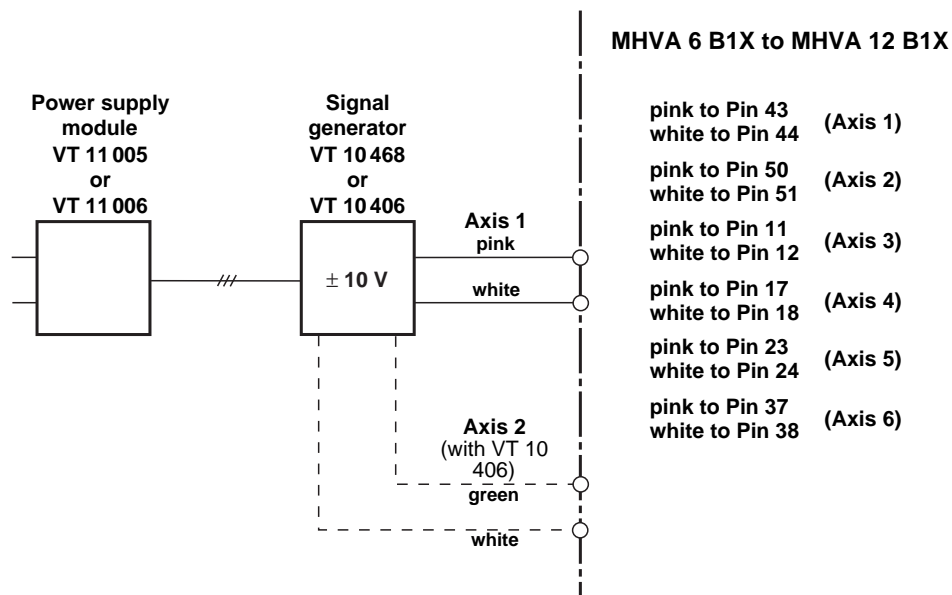

**Ordering Code**

<b>MHVA</b>		<b>B</b>	<b>1X/</b>		<b>*</b>
-------------	--	----------	------------	--	----------

Amplifier for the control of 3 axes = 6  
 Amplifier for the control of 4 axes = 8  
 Amplifier for the control of 5 axes = 10  
 Amplifier for the control of 6 axes = 12

Series 10 to 19 = 1X  
 (10 to 19: unchanged technical data and terminal connections)

Operating voltage 12 VDC = G12  
 Operating voltage 24 VDC = G24

Further details in clear text

**Solenoid type/valve type:**

**D** = for direct operated proportional solenoids  
**E** = for proportional valve type DRE 4 K  
**F** = for proportional valve type FTDRE 2 K  
**P** = for EP-pump displacement

We supply as standard version: MHVA 6 B1X/G24D

The plug set **MHV.B** is included in delivery, but may also be ordered separately (order-no. 00571360).

It consists of: 1 plug  
 10 contacts "Junior-Timer" (0,5 to 1,5 mm<sup>2</sup>)  
 50 contacts "Micro-Timer" (0,5 to 1,0 mm<sup>2</sup>)

**Unit dimensions**

(Dimensions in mm)

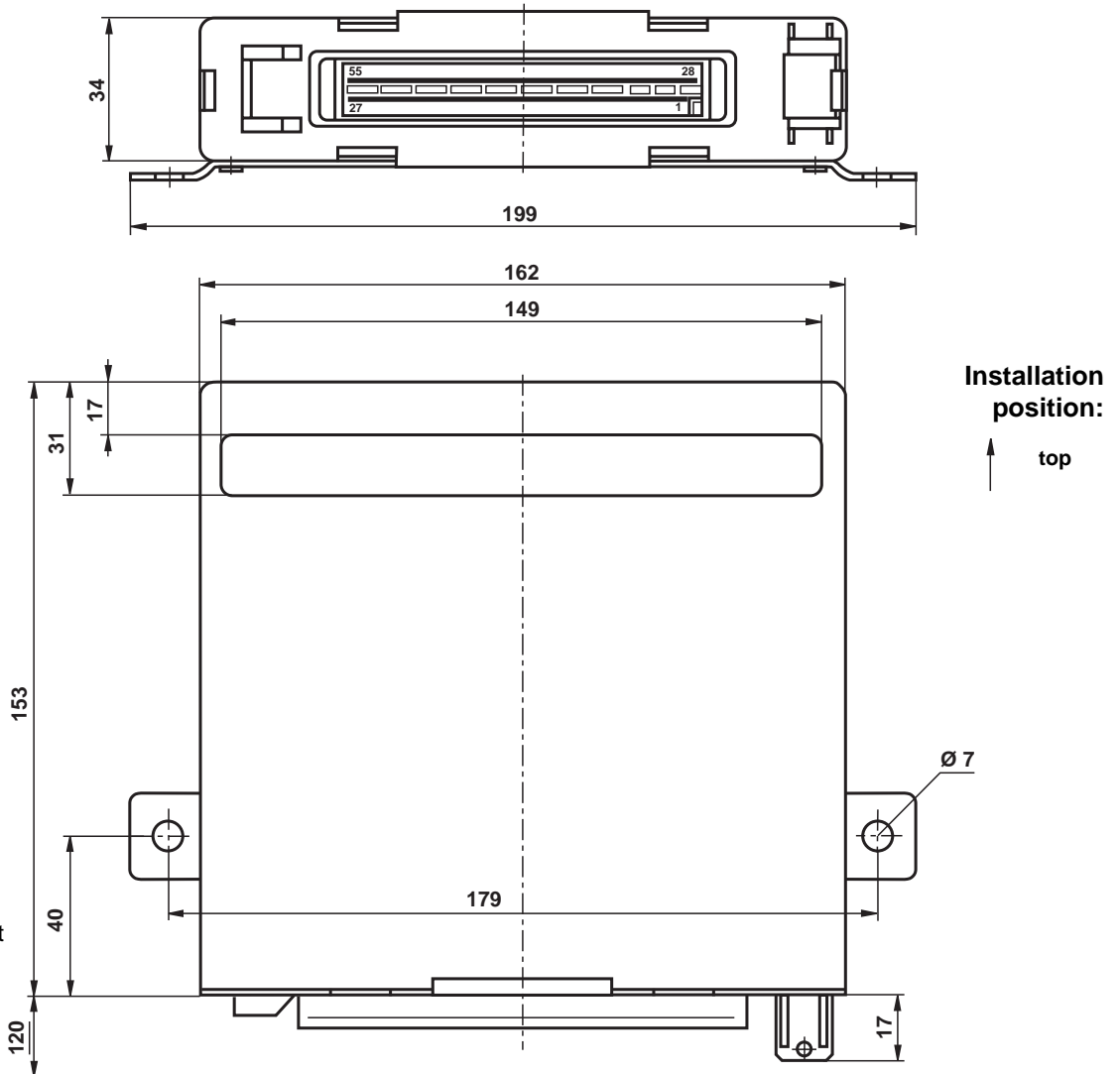

**Mannesmann Rexroth GmbH**  
 D-97813 Lohr am Main  
 Jahnstraße 3-5 • D-97816 Lohr am Main  
 Telefon 0 93 52 / 18-0 • Telefax 0 93 52 / 18-10 40  
 Telex 6 89 418

**Mannesmann Rexroth Limited**  
 Cromwell Road, St. Neots,  
 Huntingdon, Cambs. PE19 2ES  
 Tel: (01480) 476041  
 Fax: (01480) 219052