

**RE 95 022/05.99**

Replaces: 12.95



## Proportional Amplifier PVR for reversing drives

Series 11

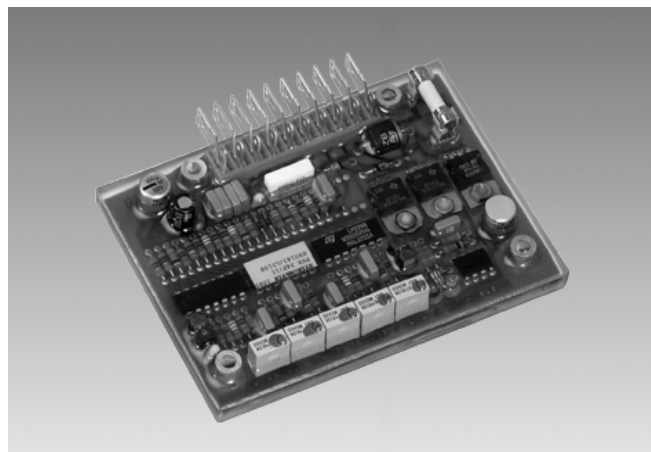

PVR24F/11

### Features

The proportional amplifier PVR is used for control of a variable displacement pump or a valve with two proportional solenoids.

As input signal the amplifier PVR is processing the control voltage adjustable by means of a potentiometer.

As output signal the amplifier is providing a closed loop electric current, e. g. for control a variable displacement pump A4VG (RE 92003) or A10VG (RE 92750).

### Main components

- Voltage stabilisation
- 2 PWM output stages ((pulse width modulation)
- Time ramp function for demand value
- Multiple trimmer potentiometer for precise settings of the solenoid currents and time ramp
- LED display for functions
- Circuit board poured in synthetic

### Special characteristics

- Differential amplifier input for different potentiometer connections
- Optional external control with a voltage signal, e.g. from a SPC (stored program control)
- Solenoid current pulse width modulated (PWM) for minimum hysteresis
- Solenoid current closed loop controlled, i.e. voltage and temperature independent
- Solenoid outputs overload protected
- Overvoltage protection
- Optional linear or progressive output characteristic curve

### Ordering Code

		PVR				/ 1 1 -			
<b>Type</b>		Proportional amplifier for reversing drives							
		PVR							
<b>Voltage supply</b>									
U = 12 V nominal voltage		12							
U = 24 V nominal voltage		24							
<b>Model</b>		Flat pin vehicle plug							
		F							
<b>Series</b>									
		1							
<b>Index</b>									
		1							
<b>Operating curve</b>									
Linear curve (no code)									
Progressive curve				P					

## Technical Data

Type	PVR12F/11	PVR24F/11
Nominal voltage	12 V	24 V
Voltage supply	10...17 V DC	18...33 V DC
Residual ripple (DIN 40839/1)	max. + 2 V	
Overvoltage protection (supply)	suppressor diode	
Reverse voltage protection (supply)	response of the fuse on the circuit board	
Current consumption, without load	approx. 30 mA	
Current consumption, maximum	<1,6 A	
Fuse on the circuit board	1,6 AT	
Resistance of the ext. potentiometer	1 k $\Omega$ ...10 k $\Omega$	
Signal input voltage	0 V...8,5 V	
Dead band (outputs switched off)	4,25 V $\pm$ 0,1 V (one potentiometer) 0 V + 0,1 V (two potentiometer)	
Ramp time, from $I_{min}$ to $I_{max}$	0,1 s ... 10 s, adjustable	
Output current, max. (load depend.)	1500 mA	750 mA
Start current, adjustable	0...500 mA	0...250 mA
Pulse frequency (PWM-output stage)	100 Hz $\pm$ 5% $\pm$ 20 Hz	
Switching output, max. current	1000 mA	
Ambient operating temperature	-25°C ... +70°C	
Weight	approx. 0,15 kg	

## Description

### Function

By means of the amplifier PVR each time one of the two proportional solenoids is charged with current, proportionally dependent from the input signal, whereas the other solenoid is without current.

Up to the execution this correlation is either linear (PVR...) or progressive (PVR...-P). To assure in "zero position" of the control potentiometer, that none of the solenoids is operating, both magnetizing currents are disconnected in the range of a dead band at medium control voltage.

At fast modification of the input signal the output current is "retarded" by means of a time ramp function. The time for the course from  $I_{min}$  till  $I_{max}$  is adjustable between 0,1 s and 10 s.

The output stage is working almost free of losses by pulse width modulation (PWM) with a pulse repetition rate of 100 Hz. The current closed loop control is effected by modification of the duration of connection resp. disconnection. Temperature related resistance modifications in the proportional solenoid circuit and variations of the operating voltage are settled. At overload in the solenoid circuit the connection time is reduced to a min. value of 0,5 ms harmless for the output stage.

The start current  $I_{min}$  and the max current  $I_{max}$  may be set separately for "forward" and "reverse" direction of travel.

### Compatibility of series 11 to series 10

#### PVR.../11:

The amplifiers PVR.../11 are regarding function and connections compatible to PVR.../10.

#### Please note:

At cable break or short circuit at the input side of the potentiometer non-desired modifications of the output current may occur. For safety relevant applications possibly the amplifier RVR (RE 95031) with safety control or the microcontroller MC (RE 95 050) has to be used instead of the amplifier PVR.

## Characteristics

### Amplifier control

The amplifier may be controlled by means of one or two potentiometer. Furthermore the control by means of a signal voltage, e.g. of a stored program control (SPC) is possible.

#### 1) Control with a single potentiometer

The electrical neutral is in the mid position of the potentiometer

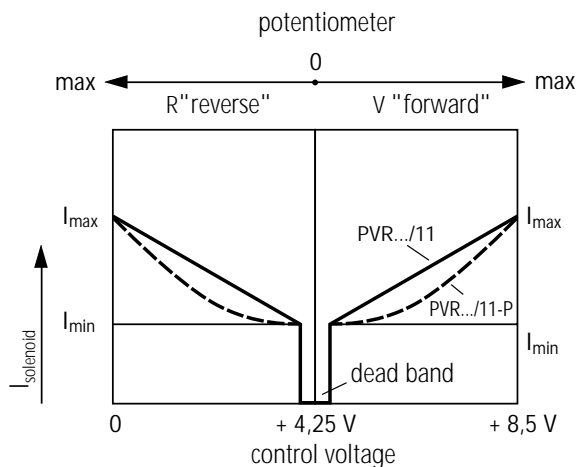

#### 2) Control with two potentiometers

One potentiometer for travel direction "forward"

One potentiometer for travel direction "reverse"

#### Note:

When the forward control potentiometer is in use, the reverse potentiometer must be at zero and vice versa.

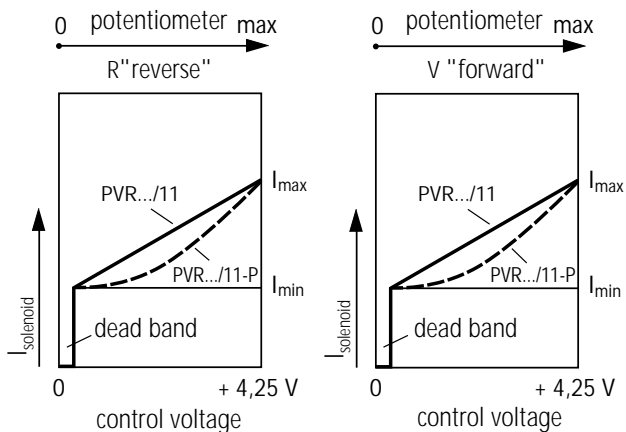

## Block Circuit Diagrams

Re 1): Control with a single potentiometer

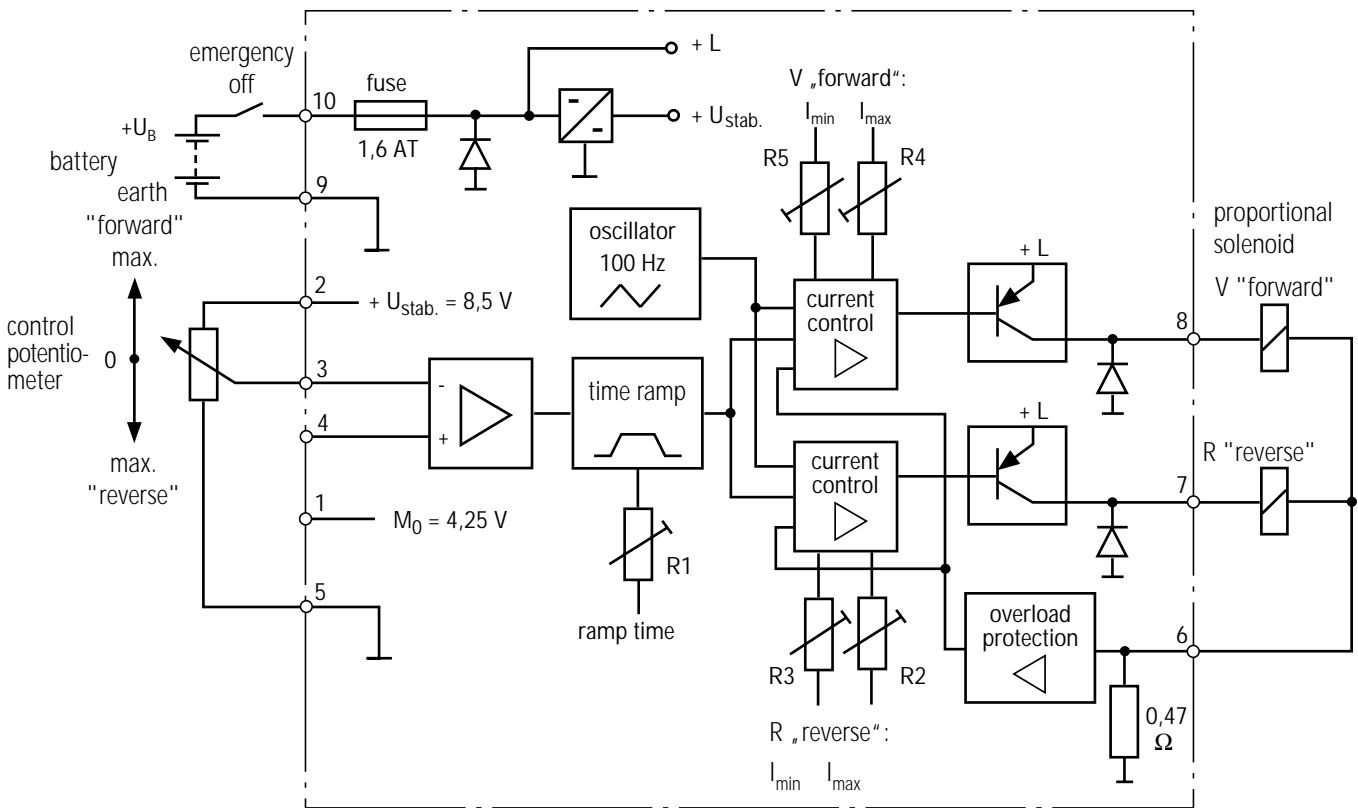

Control with a single potentiometer and directional selection switch

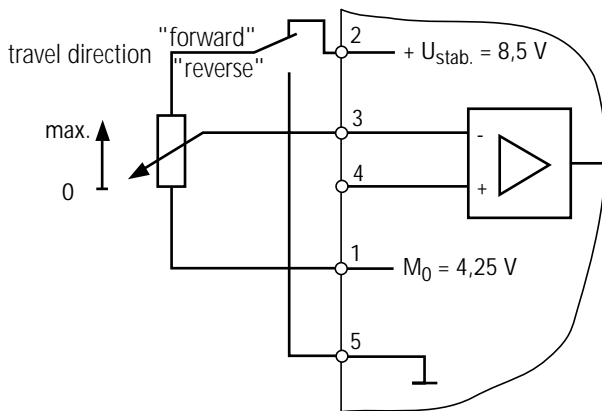

Control by means of an external voltage signal

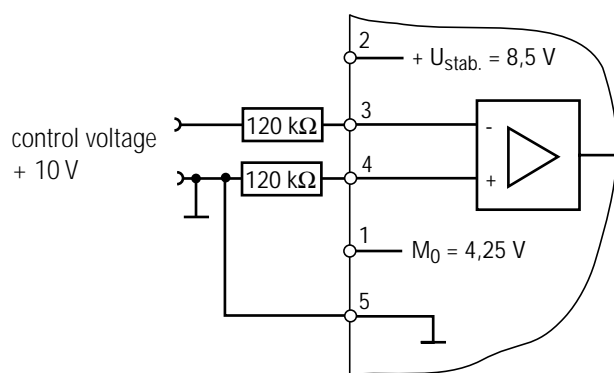

Re 2): Control with two potentiometers

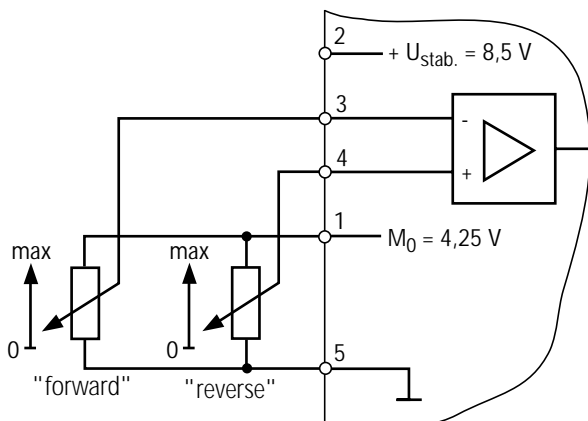

## Connection Diagrams

Control with a single potentiometer

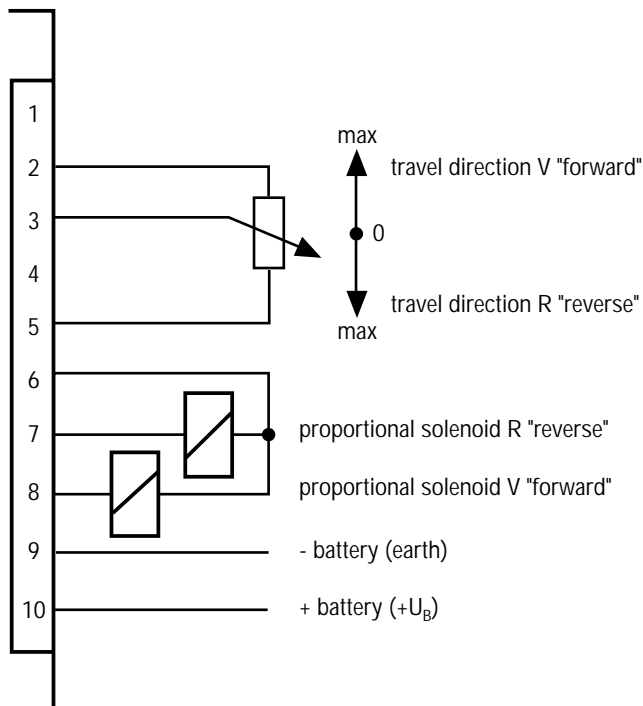

Control with a single potentiometer and a directional selection switch

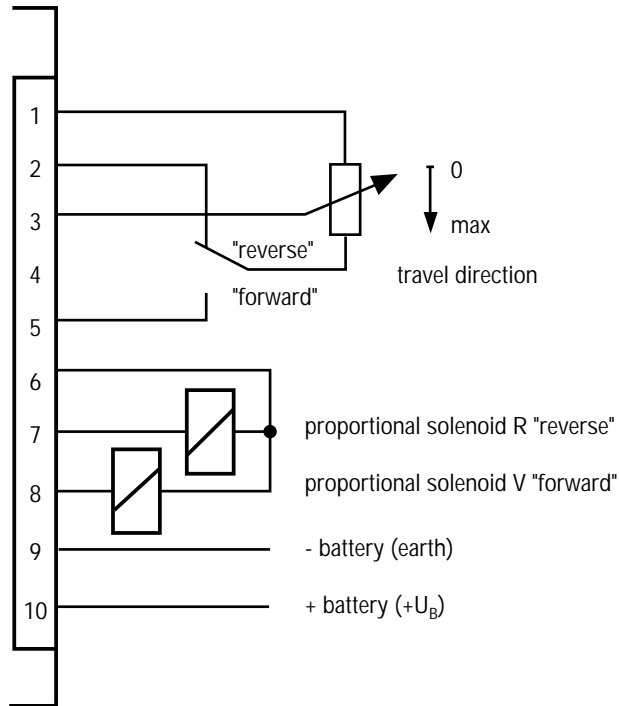

Control with two potentiometers

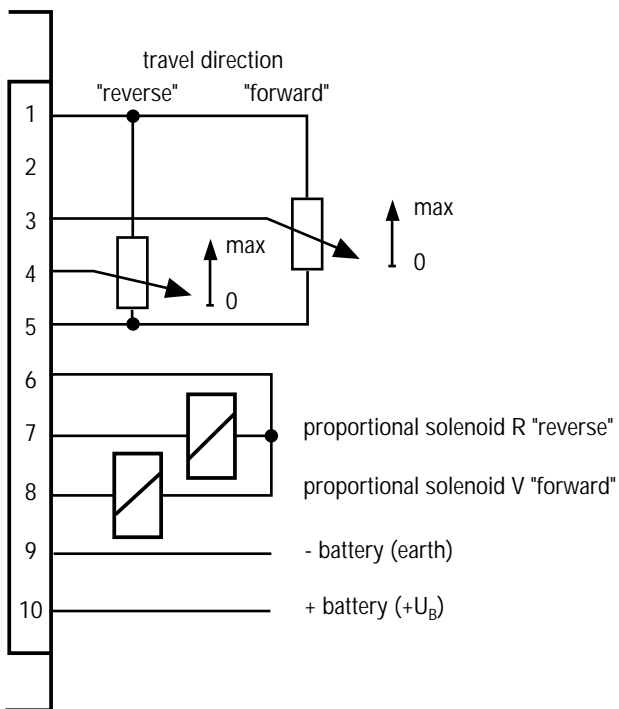

Control by means of an external voltage signal

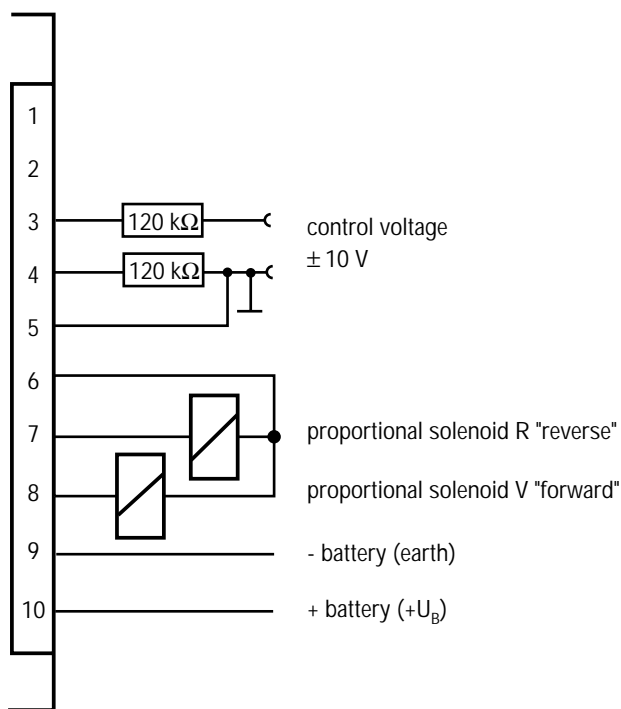

**Unit Dimensions**

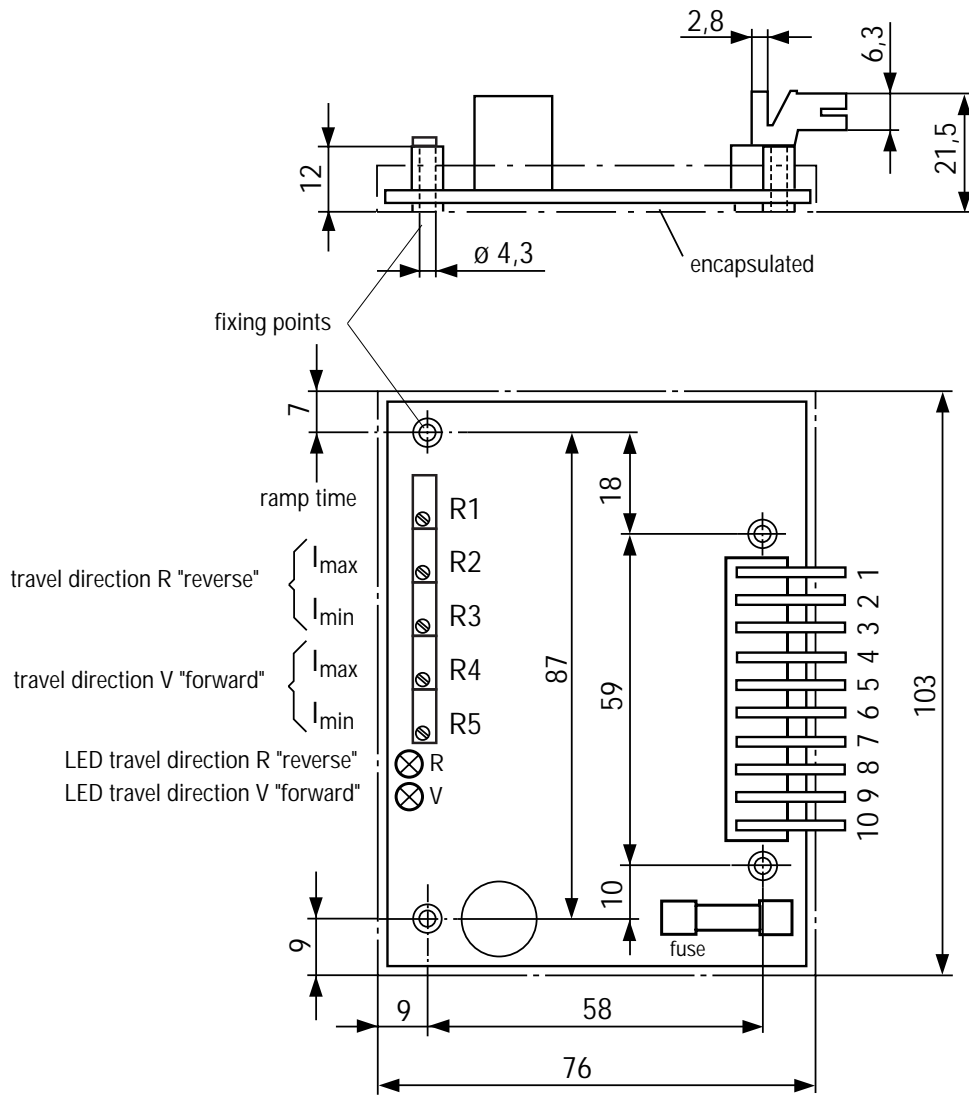

The counterplug connectors consist of individual pin connectors AMP-Faston size 6,3 are not included.

**Use only connectors with insulation!**

**Presetting for delivery**

(suitable in connection with variable displacement pump A4VG or A10VG)

Amplifier	PVR12.../11	PVR24.../11
Nominal voltage	12 V	24 V
Solenoid current V ("forward")	$I_{min} = 400 \text{ mA}$ $I_{max} = 1200 \text{ mA}$	$I_{min} = 200 \text{ mA}$ $I_{max} = 600 \text{ mA}$
Solenoid current R ("reverse")	$I_{min} = 400 \text{ mA}$ $I_{max} = 1200 \text{ mA}$	$I_{min} = 200 \text{ mA}$ $I_{max} = 600 \text{ mA}$
Ramp time	approx. 5 s	approx. 5 s

**Setting Instruction PVR.../11**

(change of presetting)

1. Acting control potentiometer until LED "V" or LED "R" starts to light. Adjust start current  $I_{min}$  with R5 or R3. (current increase by rotating in clockwise direction)
2. Set control potentiometer to maximum forward "V" or reverse "R". Adjust maximum current  $I_{max}$  with R4 or R2. (current increase by rotating in clockwise direction)
3. The same adjustment for the reverse direction ("V" or "R").
4. Adjust duration of time ramp with R1. (ramp time increase by rotating in clockwise direction)

- Please note:**
- Brueninghaus Hydromatik cannot accept any responsibility for technical problems occurring within the system arising from using a circuit diagram based on the recommendation.
  - The Safety Regulations (RDE 90301-01) are to be observed.
  - An emergency switch must be fitted to cut off the power supply to the electronics in the event of an emergency. This switch must be easily accessible to the operator.  
Safe and effective braking must be guaranteed on operating the emergency switch.
  - Lines to the electronics may not be laid in the vicinity of other power lines in the equipment.
  - There must be sufficient distance between any radio equipment.
  - During welding operations all electrical connectors to the electronics must be unplugged.
  - Only test the electronics when proportional solenoids are connected.
  - The proportional solenoid may not be fitted with free wheeling diodes.
  - Switching solenoids at outputs of the electronics and other inductive actuators within the system must be fitted with free wheeling diodes.
  - External switching contacts in the solenoid lines are not permitted.

---

**Brueninghaus Hydromatik GmbH**

**Plant Elchingen**

Glockeraustraße 2 • D-89275 Elchingen

Phone +49 (0) 73 08 / 82-0

Telefax +49 (0) 73 08 / 72 74

The specified data is for product description purposes only and may not be deemed to be guaranteed unless expressly confirmed in the contract.