

# Technical Specifications

RA 17 038-DT1TS/10.07 1/8  
Replaces: 03.04

**Model CDT1/CGT1**

## CDT1 Technical Specifications

### Background

The CDT1 is based upon a newly developed Bosch Rexroth and NFPA-design hydraulic cylinder.

CDT1 is designed as a standard product in the Bosch Rexroth Hydraulic Cylinder Program, and will be exclusively manufactured by Bosch Rexroth Industrial Hydraulics Division. It will be marketed in the United States as well as internationally by the Bosch Rexroth Industrial Hydraulics division.

The CDT1 is designed according to the NFPA Standard.

The CDT1 is designed as a domestic product, meaning it will be manufactured within the United States using standard English measurements.

### Standard

CDT1 complies with:  
National Fluid Power Association (NFPA)  
ANSI/T3.6.7R2-1996

### Pressure Rating

The CDT1 is primarily intended for up to 1,500 psi continuous duty. Depending on bore size.

Since the overall dimensions of the CDT1 are determined by ANSI/T3.6.7R2-1996, the dimension of the mounting styles cannot be deviated. The CDT1 has been calculated and verified through laboratory tests for a maximum static pressure of 2,250 psi.

**Note:** See data sheet RA 17 038 for pressure limitations.

### Fluid Compatibility

The CDT1 in its basic design is intended for use with mineral oil, according to NFPA Standard.

NOTE: Phosphate ester, HFA, and Water glycol HFC may be used if seal materials, such as polyurethane and thermoplastic polyester, are avoided. See information under "Options".

### Design

The CDT1 is a hydraulic cylinder of tie rod design, meaning the head and cap are secured to the cylinder tube with tie rods that are tightened with nuts.

A listing of the individual parts of the basic cylinder can be found on page 2 and 3. The item numbers refer to the detailed parts drawing on page 6.

Item	Description
1	Head – steel 1117 or ductile iron 65-45-12 – The head has fluid connection, port air-bleed and cushion valve if required.
2	Tube – steel – honed or polished to a surface finish 16µin or better.
3	Piston – ductile iron 65-45-12 – with separate seal and bearing grooves. The piston has "anti-stick" grooves to prevent piston from sticking to the head or cap. This is especially a risk for vertical cylinders under high external loads. The piston is held to the piston rod with a seizing compound applied to the piston thread. The piston is also secured to the rod by means of a set screw, which is tightened and secured with a seizing compound. The set screw is located in one of the wear band grooves, so any surface which could potentially chafe the inside of the tube is protected by the wear band.
4	Cap – steel 1117 or ductile iron 65-45-12 – The cap has fluid connection port air-bleed and cushion valve if required.
5	Flange – steel 1117 – held directly to head by hex head bolts. Also retains rod bearing. This also applies to 8" bore sizes, all mounts.
6	Cushion bushing (head end) – ductile iron 65-45-12 – The bushing is retained between a shoulder on the piston rod and the piston itself.
7	Cushion insert (cap end) – 660 bronze floating insert held in place by retainer ring (Item 8).
8	Cushion insert retainer ring (cap end only) – steel – retains cushion insert on cap end.
9	Tie-rod – 1045 steel – high tensile, stress-proof.
10	Piston rod – steel 1050 – with chrome layer 0.5-1.0µin and surface finish 16µin Ra or better. Induction hardened end to 50 - 55 HRC up to 4" diameter.
11	Air-bleed screw – steel – seals without elastomeric seals in head and cap. Standard on 2" - 8" bores. Not available on 1" or 1-1/2" bore sizes.
12	Securing screw – steel – for air-bleed screw. Prevents unintentional loosening of the air-bleed screw. Not available on 1" or 1-1/2" bore sizes.
13	Tie rod nuts – steel – grade 8, zinc-plated.
14	Set screw – steel – used to mechanically lock piston to the piston rod.

- 15 Hex Head bolt – steel - grade 8, zinc plated.
- 16 Rod bearing – 65-45-12 ductile iron – extra-long rod bearing provides for maximum support against side-loads including external misalignment. Ductile iron has superior non-scoring properties and dimensional stability. Bearing is pilot fitted into the head assuring true concentricity. Rod bearing can be changed without special tools. Internal spiral groove ensures lubricity and compensates for pressure changes. The rod bearing contains grooves for rod wiper and rod seal.
- 17 "Exact-a-Just" cushioning valve – provides an accurate micrometer adjustment for cushioning, permitting a wide range of settings. May be supplied at head, cap, or both ends. The combination needle and check valve eliminates the need for separate ball checks, thus leaving a quadrant free for other possible use. Not available on 1" bore sizes.
- 18 Threaded stud – ASTM A19 – fits into female threaded piston rod.
- 19 Standard "M" seal option
- Double-acting wiper – polyurethane – acts also as secondary piston rod seal. Other materials are available for special applications. See "Options" on page 5 for more information.
  - Piston rod seal – polyurethane – U-cup shaped. Other materials are available for special applications. See "Options" on page 5 for more information.
  - Bearing o-ring – nitrile rubber – standard
  - Bearing backup o-ring – PTFE – split ring.
  - O-ring – nitrile rubber. One at each end of the tube.
  - Backup o-ring – PTFE – asymmetric shape fitting o-ring radius. One at each end of the tube.
  - Piston seal – Polyurethane with o-ring energizer. Nitrile rubber is the standard configuration. Other seal systems are available for special applications. See "Options" on page 5 for more information.
  - Piston wear bands – fabric reinforced phenolic resin.
- 20 Socket Head Cap Screws – steel – Secures retainer plate to head end (not shown). Also standard on 8" bore sizes – all mounts

## Mounting Styles

- MX0 Basic version – no mounting
- MF1 Rectangular flange at head
- MF2 Rectangular flange at cap
- MF5 Square flange at head
- MF6 Square flange at cap
- MP1 Clevis mounting
- MP3 Pivot mount
- MP5 Pivot mount with spherical bearing
- MS2 Side lug
- MS3 Centerline lug
- MS4 Side tapped
- MS7 End lugs
- MT1 Trunnion at head
- MT2 Trunnion at cap
- MT4 Trunnion at intermediate position
- MX1 Extended tie rods at both ends
- MX2 Extended tie rods at cap
- MX3 Extended tie rods at head

## Sizes

The following are included in the CDT1:

Bore Ø (inches)	Rod Ø (inches)
1.000	0.500
	0.625
1.500	0.625
	1.000
2.000	0.625
	1.000
	1.375
2.500	0.625
	1.000
	1.375
	1.750
3.250	1.000
	1.375
	1.750
	2.000
4.000	1.000
	1.375
	1.750
	2.000
	2.500
	3.500
5.000	1.000
	1.375
	1.750
	2.000
	2.500
	3.000
	3.500
6.000	1.375
	1.750
	2.000
	2.500
	3.000
	3.500
	4.000
	5.000
8.000	1.375
	1.750
	2.000
	2.500
	3.000
	3.500
	4.000
	4.500
5.000	
5.500	

## Piston Rod Seal / Bearing

There are normally very high demands on the sealing function between the piston rod and the head. Polyurethane seals are well proven with regards to wear resistance. In order to maximize the wear life of the piston rod seal, it is necessary to maintain the piston rod in a concentric position. By using a bearing that is separate from the head, the cylinder is able to hold a tight seal on the internal pressure. Replacement of the piston rod bearing does not require replacement of the entire head and complete disassembly of the cylinder.

## Piston

The piston utilizes spiral grooves on each side to reduce break away force and prevent it from "sticking" to the end cover during operation.

## CDT1 – Options

### Port Connections / Types

#### Option S

Standard SAE straight thread ports according to ISO 11926-1.

### Port Connections / Location

#### Location 1, 2, 3, and 4

Port location at 12,3, 6, and 9 o'clock, respectively, as seen from the piston rod side of the cylinder. Location 1 is standard.

## Piston Rod Version

### Option H

Case-hardened to 50-55 Rockwell "C" and hard chrome plated. Hardening thickness 50µin. Surface finished to 16µin or better. Rod diameters above 4" are not case hardened.

### Option S

17-4 PH stainless steel, chrome plated.

## Piston Rod End

### Option H

Small male thread KK1. Studded rod end standard up to 1" - 14 male thread

### Option D

Intermediate male thread KK2.

**Option E**

Female thread KK1.

**Option T**

Self-Aligning Flange End (S.A.F.E.) rod end.

**Cushioning****Option U**

Cylinder without cushioning.

**Option D**

Adjustable cushioning at both the cap and head ends of the cylinder. Not available on 1" bore size.

**Option S**

Adjustable cushioning at head end only.  
Not available on 1" bore size

**Option K**

Adjustable cushioning at cap end only.  
Not available on 1" bore size

**Seal Version**

All seals utilize the same seal grooves. The piston or rod bearing does not have to be replaced if changing from one seal material to another.

**Option M**

Standard seal version – wiper, rod seal and piston seal – are made of polyurethane. Recommended for mineral oil applications. Water glycol type fluid is not compatible with this material.

Recommended temperature range: -4°F - +176°F.

**Option T**

Low friction seal version differs from version **M**. The piston seals includes a glide ring of bronze-filled PTFE with a NBR o-ring energizer (nitrile rubber). The excluder wiper and dual step seals are bronze filled PTFE with an NBR o-ring energizer (nitrile rubber).

**NOTE:** The glide ring on the piston cannot be considered completely leak tight. Static loads on the piston should be avoided.

Recommended temperature range: -4°F - +176°F.

**Option F**

Intended for use with water glycol type fluids. The piston rod seal, rod wiper and the piston seal is the same as Option T with a NBR o-ring energizer (nitrile rubber).

**NOTE:** The glide ring on the piston cannot be considered completely leak tight. Static loads on the piston should be avoided.

Recommended temperature range: -4°F - +140°F.

**Option V**

Version for use with phosphate ester type fluids or for high temperature applications. The piston rod seal, rod wiper and the piston seal is the same as in option **T**, with the difference being an FPM o-ring energizer.

**NOTE:** The glide ring on the piston cannot be considered completely leak tight. Static loads on the piston should be avoided.

Recommended temperature range: -4°F - +300°F.

For applications above 250°F specify a non studded rod end and advise operating temperature

**Option 1****Option W**

Select this if no options are required.

**Option E**

Proximity switch. (both sides)

**Option A**

Test point, both sides. Not available on 1" bore size.

(See data sheet RA 17 038 for further details on above options)

**Option 2****Option W**

Select this if no options are required.

**Option K**

Thrust key. For use with the MS2 mount.

**Option S**

Stop tube.

**Option Y**

Piston rod extension. Customer-specified length is added to overall piston rod length.

(See data sheet RA 17 038 for further details on above options)

## Exploded View Drawing

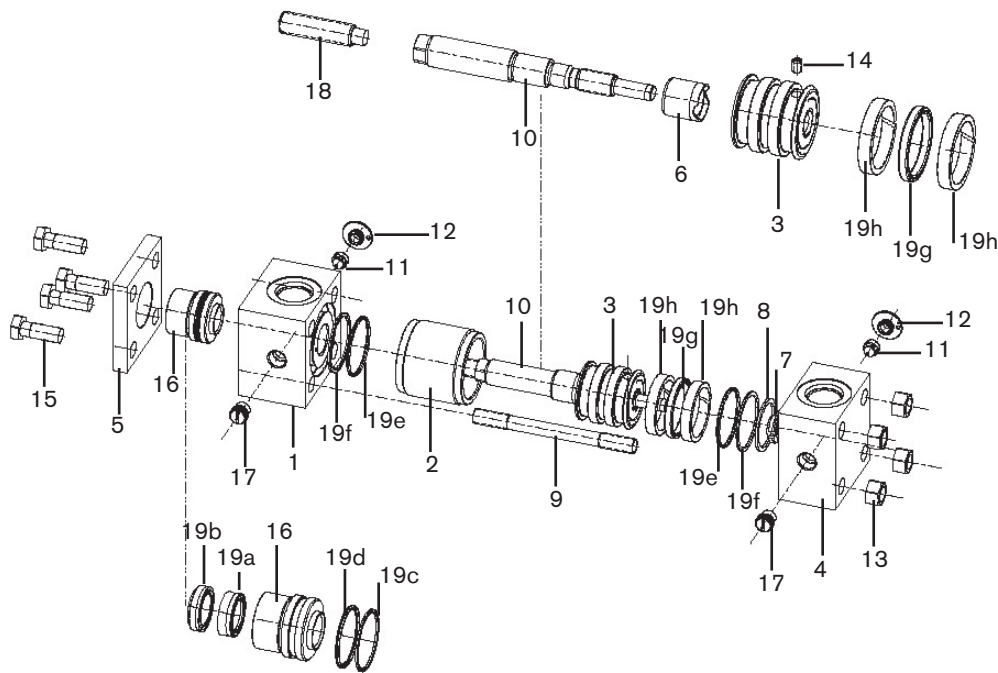

1. Head
2. Tube
3. Piston
4. Cap
5. Flange
6. Cushion bushing
7. Cushion insert
8. Cushion insert retainer ring
9. Tie rod
10. Piston rod
11. Bleed screw
12. Securing plate
13. Tie rod nut
14. Set screw
15. Hex head bolt
16. Rod bearing
17. Cushion valve
18. Threaded stud
19. Seals
  - a. Wiper
  - b. Rod seal
  - c. Bearing o-ring
  - d. Bearing backup ring
  - e. Tube o-ring
  - f. Tube backup ring
  - g. Piston seal
  - h. Wear bands

## CDT1 Weight/Torque Values

Approx. Uncrated CDT1 Hyd. Cyl. Weights (lbs).			Tie Rod Nuts and Bolts			Socket Head Cap Screw (all 8" bore sizes)		
Bore Size (inches)	Zero Stroke	Add Per Inch of Stroke	Bore Size (inches)	Tie Rod Threads	Torque Lubricated (pound-ft)	Rod Size	SHCS Size	Torque Lubricated (pound-ft)
1.00	3	0.2	1.000	10 - 24	2	All	1/2 - 13	74
1.50	5	0.3	1.500	1/4 - 28	4.5			
2.00	7	0.4	2.000	5/16 - 24	9			
2.50	12	0.6	2.500	5/16 - 24	12			
3.25	20	0.8	3.250	3/8 - 24	22			
4.00	30	0.9	4.000	3/8 - 24	22			
5.00	45	1.0	5.000	1/2 - 20	45			
6.00	70	1.5	6.000	1/2 - 20	45			
8.00	100	2.0	8.000	5/8 - 18	90			

\* Note: Weights are based upon a standard rod diameter. With multiple rod sizes and mounting options available, these weights may vary.



Bosch Rexroth Corporation  
Industrial Hydraulics  
2315 City Line Road  
Bethlehem, PA 18017-2131  
USA  
Telephone (610) 694-8300  
Facsimile (610) 694-8467  
[www.boschrexroth-us.com](http://www.boschrexroth-us.com)

© 2004 Bosch Rexroth Corporation

All rights reserved. Neither this document nor any part of it may be reproduced, duplicated, circulated or disseminated, whether by copy, electronic format or any other means, without the prior consent and authorization of Bosch Rexroth Corporation.

The data and illustrations in this brochure/data sheet are intended only to describe or depict the products. No representation or warranty, either express or implied, relating to merchantability or fitness for intended use, is given or intended by virtue of the information contained in this brochure/data sheet. The information contained in this brochure/data sheet in no way relieves the user of its obligation to insure the proper use of the products for a specific use or application. All products contained in this brochure/data sheet are subject to normal wear and tear from usage.

Subject to change.