

Service case with test unit for servo-valves without integrated electronics

RE 29681/06.05
Replaces: 07.02

1/6

Type VT-SVTSY-1

Series 1X



H6100_d

Table of contents

Contents	Page
Features	1
Ordering code	2
Test unit type VT-SVT-1-1X	3
Functional description / operating instructions	3
Block circuit diagram / pin assignment	3
Test unit type VT-SVT-1-1X: Technical data	4
Unit drawing	4
Overview of servo-valves that are suitable for testing	4
Accessories: Power supply unit type VT-SVTNT-2-1X/G12	5
Technical data	5
Accessories: Valve connecting cable	6

Features

- The service case includes a test unit with 9 V block battery and optionally a power supply unit and connecting cable (see ordering code)
- The test unit is suitable for commissioning and servicing work on hydraulic systems that are fitted with servo-valves without integral electronics
- Allows functional testing and localisation of faults in the case of machinery malfunction without removal of the servo-valve
- Voltage supply by 9 V block battery or 12 V power supply unit
- Service case:

• Dimensions (W x H x D)	450 x 100 x 350 mm
• Weight	empty 2 kg
	complete 3.2 kg

Note:

The unit may only be used by personnel who are familiar with the test unit, the valve and the hydraulic system. We will not assume liability for damage caused by wrongful operation!

Information on available spare parts:
www.boschrexroth.com/spc

Ordering code

VT-SVTSY-1 -1X/ 1 - - - - / *

Service case with test unit
for servo-valves without integral electronics

Series 10 to 19
(10 to 19: unchanged technical data
and pin assignment) = 1X

Test unit type VT-SVT-1-1X = 1

Connecting cable for valves with electrical connection K9 or K31:

Without connecting cable = 0

With connecting cable type VT-SVTK-1-1X = 1

Connecting cable for valves with electrical connection K17:

Without connecting cable = 0

With connecting cable type VT-SVTK-2-1X = 1

Connecting cable for valves with electrical connection K8:

Without connecting cable = 0

With connecting cable type VT-SVTK-3-1X = 1

Further details in clear text

Power supply unit 220 V/12 V:

0 = Without power supply unit

1 = With power supply unit type

VT-SVTNT-2-1X/G12

Ordering code for individual components

Designation	Type / ordering code	Material no.
Test unit for servo-valves without integral electronics	VT-SVT-1-1X	R900214710
Connecting cable with cable socket Z31	VT-SVTK-1-1X	R900939983
Connecting cable with cable socket Z17	VT-SVTK-2-1X	R900939984
Connecting cable with cable socket Z8	VT-SVTK-3-1X	R900939985
Power supply unit 220V/12 V; 580 mA	VT-SVTNT-2-1X/G12	R900946388
Service case (empty)	Case, aluminium	R900219817

Test unit type VT-SVT-1-1X

The test unit is suitable for controlling and testing the function of servo-valves without integral electronics.

Voltage is supplied to the test unit either by a 9V block battery (included in the scope of supply) or optionally by a 12V power supply unit type VT-SVTNT-2.



Functional description / operating instructions

Valve testing is carried out as follows:

- Connect the connecting cable of the power supply unit to the socket [6] of the test unit **or** insert battery [11]
- Set function switch [1] to "ON" → LED "power" [8] lights up
- For battery operation, carry out battery test:
 - Set selector switch [3] to "50 mA"
 - Set command value potentiometer [4] to "-100 %"
 - Actuate push-button [2] for battery test
 - The test unit indicates the battery charge in %
- Select coil type of the valve using selector switch [3] on the test unit

- Bring command value potentiometer [4] to the central position
- Use a suitable valve connecting cable (see ordering code) to connect the test unit (socket [7]) with the servo-valve (The valve connecting cables are to be wired so that the two coils of the servo-valve are connected in series.)
- Turn command value potentiometer [4] slowly anti-clockwise or clockwise and observe the movement of the motor or cylinder

With a fully functional servo-valve, the motor or cylinder can be sensitively controlled and moved in the required direction or to the required position.

Block circuit diagram / pin assignment

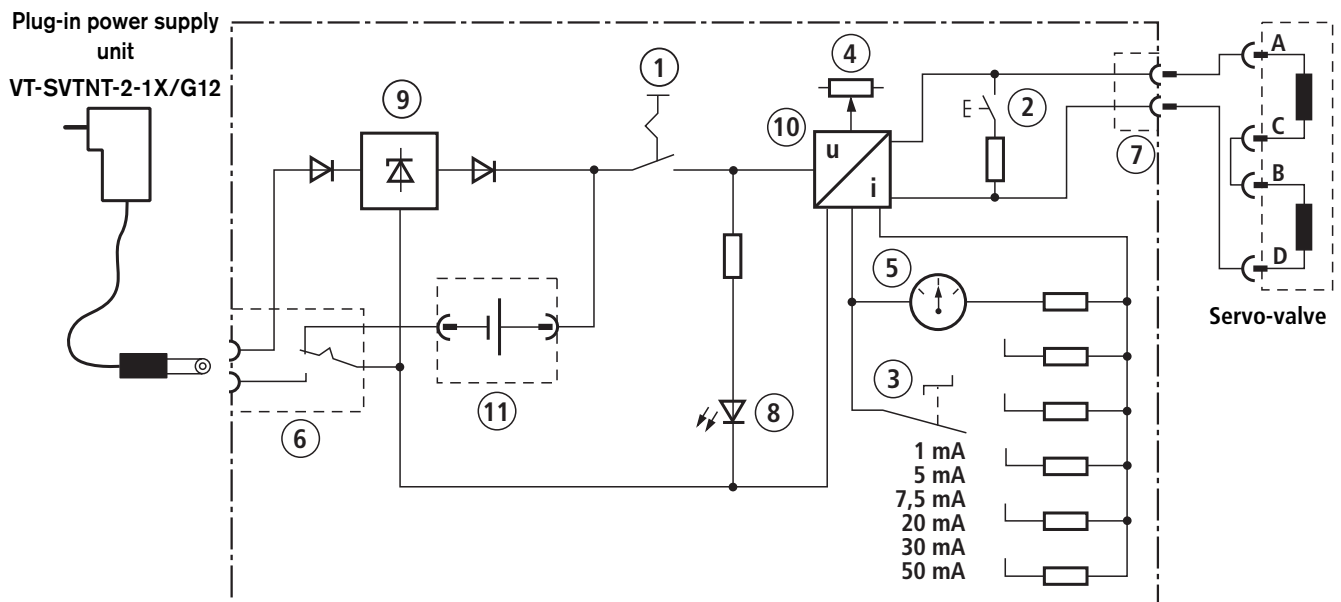

- | | | | | | |
|---|----------------------------------|----|--------------------------------------------------------|----|-------------------|
| 1 | Function switch | 5 | Coil current indicator | 8 | "power" LED |
| 2 | Pushbutton for battery test | 6 | Socket for power supply cable (with changeover switch) | 9 | Voltage regulator |
| 3 | Selector switch for type of coil | 7 | Socket for valve connecting cable | 10 | Output stage |
| 4 | Command value potentiometer | 11 | 9 V block battery | | |

Test unit type VT-SVT-1-1X:**Technical data** (for applications outside these parameters, please consult us!)

Operating voltages:		
– Battery operation	U_0	9 V (E-block)
– Operation with power supply unit	U_0	12 V to 16 V
Current consumption of the test unit	I	20 mA (plus valve current)
Dimensions (W x H x D)		95 x 158 x 45 mm
Weight	m	0.34 kg

Unit drawing

- 1 Function switch
- 2 Pushbutton for battery test
- 3 Selector switch for type of coil
- 4 Command value potentiometer
- 5 Coil current indicator (in %)
- 6 Socket for power supply unit cable
- 7 Socket for valve connecting cable
- 8 "power" LED

Assignment of coil data to valve types:

5 mA / 500 Ω per coil	} 4WS2E.10-4X
7.5 mA / 200 Ω per coil	
20 mA / 80 Ω per coil	
30 mA / 40 Ω per coil	
50 mA / 28 Ω per coil	
30 mA / 100 Ω per coil	} 4WS2EM6-2X
50 mA / 80 Ω per coil	
30 mA / 100 Ω per coil	} 4WS2EM6-1X
50 mA / 80 Ω per coil	
50 mA / 80 Ω per coil	} 4WS2EM16-2X

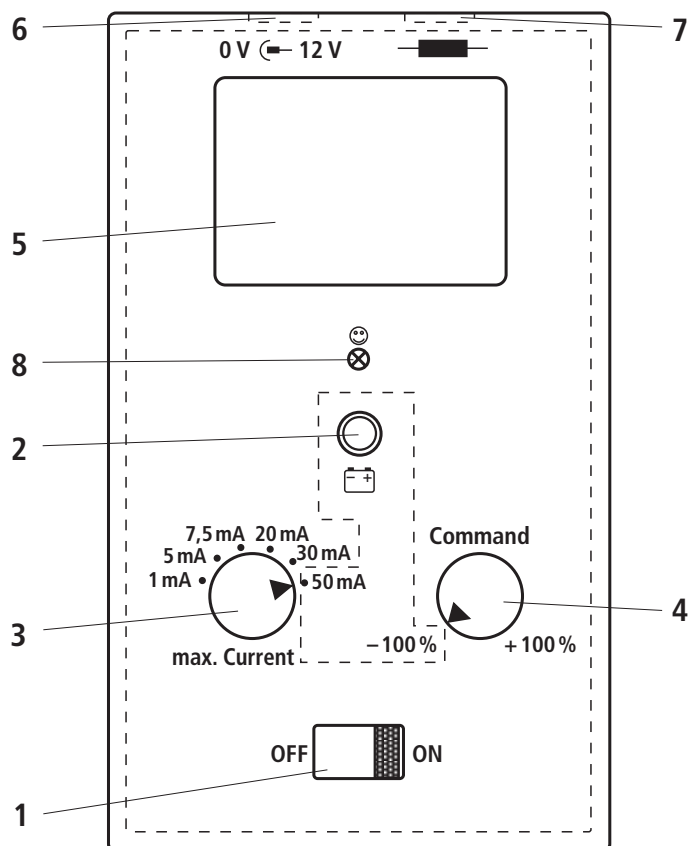
**Overview of servo-valves that are suitable for testing**

At the time of publishing this data sheet, the following Rexroth servo-valves can be tested with the VT-SVT-1 test unit:

Valve type	Electrical connection	Type of connecting cable
4WS2EM6-1X	K17	VT-SVTK-2-1X
4WS2EM6-2X	K17	VT-SVTK-2-1X
4WS2EM10-5X	K31	VT-SVTK-1-1X
4WS2EM10-4X	K8	VT-SVTK-3-1X
4WS2EB10-4X	K8	VT-SVTK-3-1X
4WS2EM10A-4X	K8	VT-SVTK-3-1X
4WS2EB10A-4X	K8	VT-SVTK-3-1X
4WS2EM16-2X	K8	VT-SVTK-3-1X
4DS1E02-1X	K8	VT-SVTK-3-1X
3DS2EH10-2X	K8	VT-SVTK-3-1X

Accessories: Power supply unit type VT-SVTNT-2-1X/G12

Plug-in power supply unit 220 VAC → 12 VDC; 580 mA



H6102_d

Technical data (for applications outside these parameters, please consult us!)

Operating voltage	U 230 VAC \pm 10 %; 50 Hz
Current consumption	I 60 mA
Fuse (thermal fuse)	t 130 °C
Output voltage	U 12 VDC; 580 mA
Length of the connecting cable to the test unit	l 2 m
Dimensions (W x H x D)	96 x 58 x 48 mm
Weight	m 0.38 kg

Accessories: Valve connecting cable

Connecting cable type VT-SVTK-1-1X

Connecting cable between VT-SVT-1 test unit and servo-valves without integral electronics (valves with ordering code **K9** or **K31** for electrical connection)

The servo-valve coils are connected in series.

Technical data (for applications outside these parameters, please consult us!)

Valve connection		Plug-in connector to E DIN 43563-BF6-3/Pg11 (series circuit)
Test unit connection		Mono jack plug 2,5 mm
Cable length	/	3 m
Weight	<i>m</i>	0.16 kg

Connecting cable type VT-SVTK-2-1X

Connecting cable between the VT-SVT-1 test unit and servo-valves without integral electronics (valves with ordering code **K17** for electrical connection)

The servo-valve coils are connected in series.

Technical data (for applications outside these parameters, please consult us!)

Valve connection		Plug in-connector VG 95328 (series circuit)
Test unit connection		Mono jack plug 2,5 mm
Cable length	/	3 m
Weight	<i>m</i>	0.3 kg

Connecting cable type VT-SVTK-3-1X

Connecting cable between the VT-SVT-1 test unit and servo-valves without integral electronics (valves with ordering code **K8** for electrical connection)

The servo-valve coils are connected in series.

Technical data (for applications outside these parameters, please consult us!)

Valve connection		Plug in-connector 14S-2P (series circuit)
Test unit connection		Mono jack plug 2,5 mm
Cable length	/	3 m
Weight	<i>m</i>	0.16 kg

Notes

Notes
