

Service case with test unit for servo and proportional valves with integral electronics (OBE)

RE 29685/11.09
Replaces: 11.04

1/12

Type VT-VETSY-1

Series 1X



H/A/D 5967/98

Table of contents

Contents	Page
Features	1
Ordering code, preferred types	2
Test unit type VT-VET-1-1X:	
– Functional description and operating instructions	3
– Block circuit diagram / pin assignment	5
– Technical data	6
– Unit drawing	7
– Connections, indicator and adjustment elements	8
– Overview of servo and proportional valves that can be tested	9
Accessories: Power supply units	10
Accessories: Connecting and adapter cables	11

Features

- The service case comprises a test unit as well as optional power supply units, connecting cables and adapter cables (see ordering code)
- The test unit can be used to control and carry out functional tests on servo and proportional valves with integral electronics and operating voltages of $\pm 15\text{ V}$ or $+ 24\text{ V}$
- Simplifies commissioning and troubleshooting in hydraulic systems with servo and proportional valves
- Service case:

• Dimensions (W x H x D)	450 x 100 x 350 mm
• Weight	empty 2 kg
	complete 4.3 kg

Caution:

The test unit may only be used by persons who are familiar with the unit, the valve and the hydraulic system. When set accordingly, the unit ignores control signals that come from the system. If safety features are provided on the control side, these are deactivated.

We assume no responsibility for damage caused by maloperation!

Ordering code

VT-VETSY-1 -1X/ 1 - - - - / *

Service case with test unit for servo and proportional valves with integral electronics

Series 10 to 19
(10 to 19: unchanged technical data and pin assignment)

= 1X

Test unit type VT-VET-1-1X

= 1

Connecting cable to valve:

Without connecting cable

= 0

With 1 off 6-pin connecting cable type VT-VETK-1-1X

= 1

With 2 off 6-pin connecting cable type VT-VETK-1-1X

= 2

Adapter cable for valve type 4WSE2EM6-1X:

Without adapter cable

= 0

With adapter cable type VT-VETAK-1-1X

= 1

Further details in clear text

Power supply unit
220 V / ± 15 VDC; 0.25 A:
0 = Without power supply unit
1 = With power supply unit
type VT-VETNT-2-1X/G15

Power supply unit
90 - 265 VAC / + 24 VDC; 3.75 A:
0 = Without power supply unit
1 = With power supply unit
type VT-VETNT-3-1X/G24

Preferred types

Type	Material no.
VT-VETSY-1-1X/1-1-0-1-0	R900943515
VT-VETSY-1-1X/1-1-0-0-0	R900945527
VT-VETSY-1-1X/1-1-1-1-1	R900951686
VT-VETSY-1-1X/1-2-1-1-1	R900951687
VT-VETSY-1-1X/1-1-1-0-0	R900962782

Test unit type VT-VET-1-1X

This test unit can be used to control and carry out functional tests on servo and proportional valves with integral electronics and an operating voltage of $\pm 15\text{ V}$ or $+ 24\text{ V}$.

Operating modes:

- External operation → looping in of the operating voltage and the command values from the control cabinet to the valve
- Internal/external operation → command value feedforward via the test unit; operating voltage from the control cabinet
- Internal operation → operating voltage provided by a separate power supply unit; command value feedforward via the test unit
- Command value provided via the BNC socket → operating voltage optional



H/A 5315/95

Typ VT-VET-1-1X

Functional description and operating instructions

Voltage supply

The test unit can be supplied with $+ 24\text{ V}$ or $\pm 15\text{ V}$, depending on the operating voltage required by the valve. To this end, the "power selector" switch must be set accordingly before commissioning.

An internal DC/DC converter generates the required auxiliary voltages of $\pm 15\text{ V}$ for the internal command value signal.

The "power selector" switch connects, among other things, the internal reference potential L0 to the mass potential applied externally.

Switch position " $+ 24\text{ V}$ " → input pin B = reference potential

Switch position " $\pm 15\text{ V}$ " → input pin C = reference potential

Connections

Input plug ES (item 1) and 4 mm input sockets:

Input plug ES on the left-hand side is used for connecting the cable coming from the control or the control cabinet. The 4 mm sockets on the left-hand side are connected directly with the pins of the ES input plug in accordance with the setting of the operating elements (see operating and indicator elements).

All signals coming from the control can therefore be measured at the sockets.

Potentiometers / trimming potentiometers

Designation	Function	Preconditions
Setpoint intern	Command value signal to valve (AB - pin D). The output switches automatically between $U_{\text{comm}} = \pm 10\text{ V}$ or $I_{\text{comm}} = \pm 20\text{ mA}$ according to the load impedance of the valve command value input.	<ul style="list-style-type: none"> – Operating voltage present at input switch ES – "power selector" switch position according to operating voltage – "setpoint selector" switch set to "intern" – "stepfunction key" pushbutton not pressed
Stepfunction level	Adjustment of the step-input amplitude. The step function can be activated using the "stepfunction key" pushbutton.	<ul style="list-style-type: none"> – Operating voltage present at input switch ES – "power selector" switch position according to operating voltage – "setpoint selector" switch set to "intern" <p>The step function is generated by pressing the "stepfunction key" pushbutton.</p>

To operate the test unit and the valve the required operating voltages of $+ 24\text{ V}$ or $\pm 15\text{ V}$ (depending on valve type) must be available.

If the operating voltage is not provided from the control cabinet, an appropriate power supply unit can be connected to the ES input plug.

Output socket AB (item 16) and 4 mm output sockets:

Output socket AB on the right-hand side is used for connecting the valve. The 4 mm sockets on the right-hand side are directly connected to the pins of output socket AB.

All the signals to or from the valve can therefore be measured at the 4 mm sockets.

The short-circuit plugs can be used to separate each individual wire of the connecting cable to allow, for example, current measurements.

BNC socket:

An externally generated command value signal may be fed in via a standard $50\ \Omega$ cable at the BNC socket.

For this, the "setpoint selector" switch must be set to position "BNC".

PE socket:

The PE socket is directly connected to the PE connection of the ES input plug. Output socket AB does not have a PE connection.

Functional description and operating instructions (continued)

LED-lamps

Designation	Function	Preconditions
power	Indication of internal voltage supply	– Operating voltage at input switch ES
enable indication control	Indication of enable signal coming from the control/control cabinet (input socket ES - pin C)	– Operating voltage is + 24 V – "power selector" switch to position "24 V" – "power" LED lights up
enable indication valve	Indication of the enable signal going to the valve (output socket AB - pin C and measuring socket C). The LED also lights up, as soon as an enable signal is applied to the 4 mm measuring socket C. Without a short-circuit plug, this signal is not applied to output socket AB, but to the valve.	– Operating voltage is + 24 V – "power selector" switch to position "24 V" – "power" LED lights up – Enable signal is activated

Switches

All the functions described are only valid as long as all short-circuit links are plugged!

Designation	Switch position	Function
power selector	+ 24 V	Internal reference potential is connected to ES - pin B (0 V to $U_B = 24$ V). The enable signal can be generated using switch "enable" ("on") or be switched off ("off").
	± 15 V	Internal reference potential is connected to ES - pin C (0 V to $U_B = \pm 15$ V).
		Enable signal generation deactivated.
		ES - pin C is directly connected to AB - pin C (short-circuit link).
enable (only with 24 V operation)	on	"setpoint selector" switch to position "control" → an external enable signal applied by the control (ES - pin C) is switched through.
		"setpoint selector" switch to position "intern" or „BNC“ → The enable signal for the valve is set.
	off	The enable signal output (AB - Pin C) is connected to the reference potential (0 V) at low resistance.
setpoint selector	control	The command value lines are connected directly from the control to the valve via pin D and pin E.
		If the "power selector" is at position "24 V" and the "enable" switch is set to "on" → then the enable signal is switched through from the control to the valve (pin C).
	intern oder BNC	"power selector" switch to position "24 V" → The enable signal is fed to the valve as with the "enable" switch position.
		The reference potential for the command value (AB - pin E) corresponds to the internal reference potential (0 V).
	intern	If the "stepfunction key" pushbutton is not actuated → then the command value signal to the valve (AB - pin D) is as preselected by means of command value potentiometer "setpoint intern".
		If the "stepfunction key" pushbutton is actuated → then the command value signal to the valve (AB - pin D) is as preselected by means of trimming potentiometer "stepfunction level".
	BNC	The signal applied to the BNC socket is used as command value signal and fed to the valve (AB - pin D).

Pushbutton

Designation	Function	Preconditions
stepfunction key	Changeover between command value signals "setpoint intern" and "stepfunction level" (pushbutton actuated)	Operating voltage applied to input switch ES. "power selector" switch position according to the operating voltage type. "setpoint selector" switch to "intern"

Block circuit diagram / pin assignment

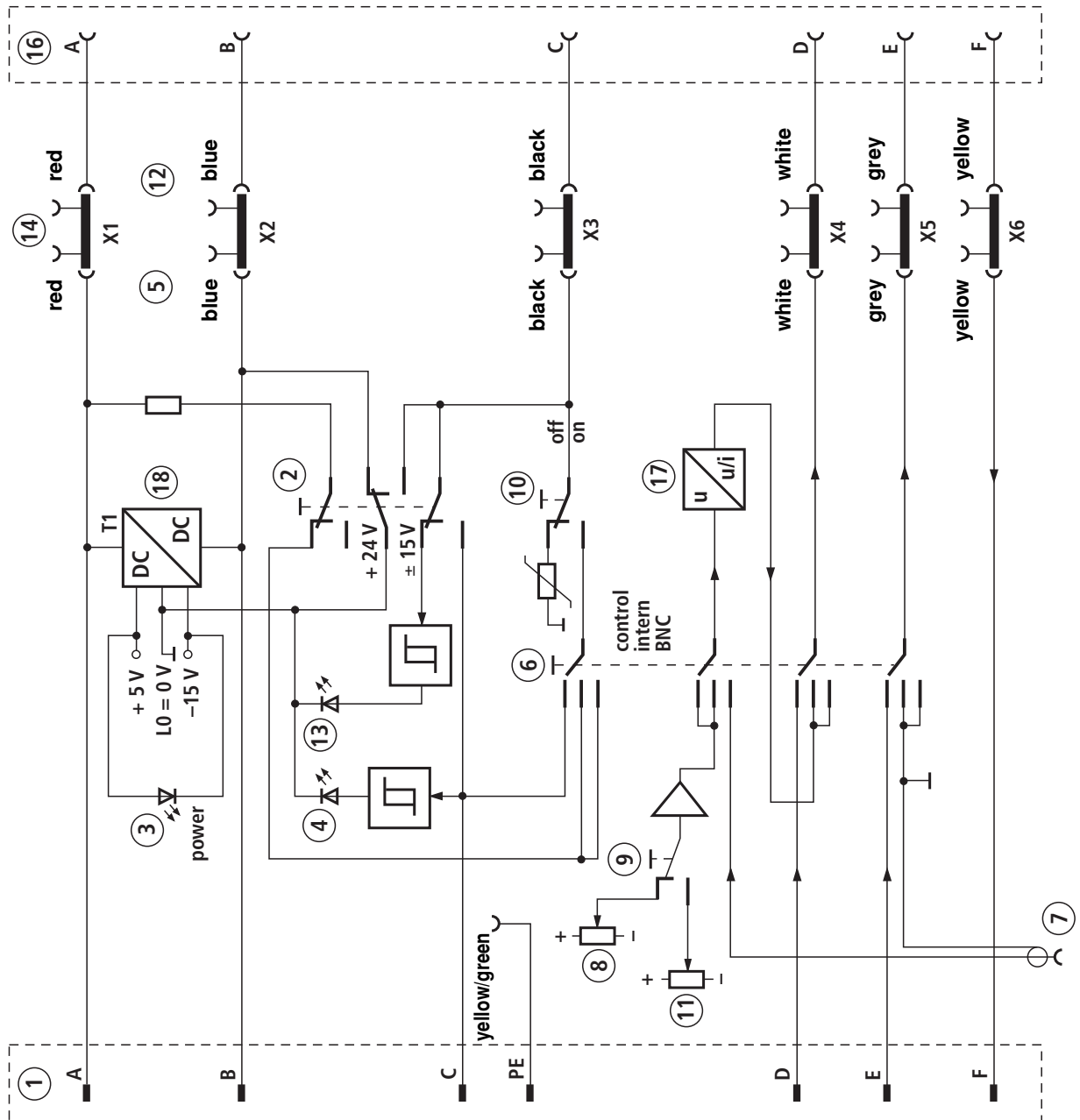

Pin assignment	
Pin	Valve version with operating voltage + 24 V
A	Valve version with operating voltage ± 15 V
B	+ 15 V
	- 15 V
C	Enable or reference potential for actual valve value, e.g. with 4WRSE
	0 V
PE	Protective earth
D	Command value +
E	Command value -
F	Actual value

Unit drawing

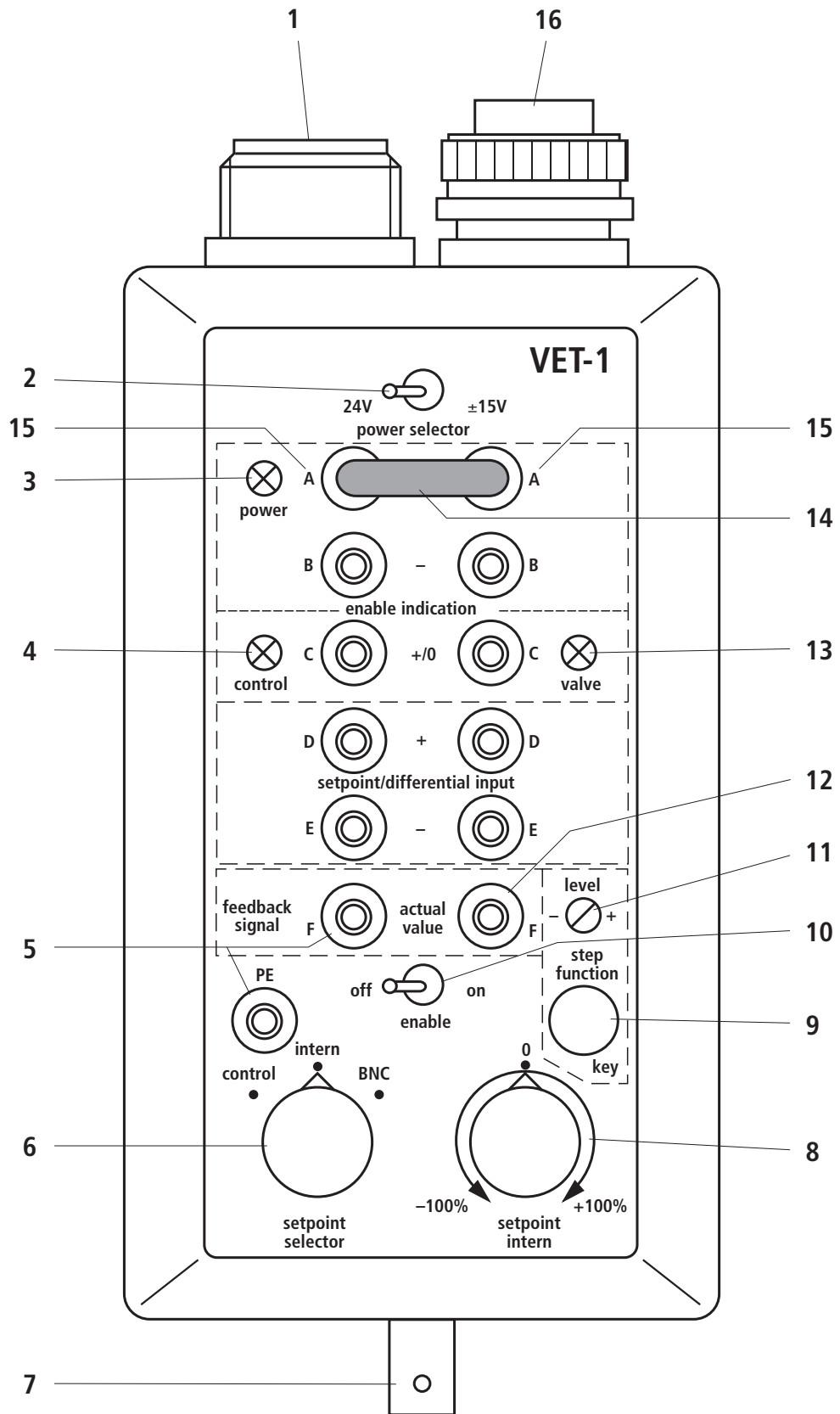

For the item numbers, see page 8

Description of connections and indicator and adjustment elements

Functional element	Labelling	Position ¹⁾
Input plug ES: Connection on the control side using component plug K31, CM02E14S-61P		1
Switch for selecting the operating voltage required by the valve	power selector	2
LED lamps:		
– Readiness for operation	power	3
– Enable signal of input plug ES and from the external control to pin C	enable indication control	4
– Enable signal to measuring sockets, output socket AB and pin C	enable indication valve	13
Input measuring sockets	A to F and PE	5
Marking of measuring sockets	A to F	15
Switch for selecting the command value signal source	setpoint selector	6
BNC socket for the connection of an external, independent command value encoder		7
Potentiometer for adjusting the internal command value signal	setpoint intern	8
Pushbutton for selecting between internal command value signals for the generation of a step-change signal	stepfunction key	9
Enable switch for the generation of an enable signal that is independent of an external control	enable	10
Trimming potentiometer for adjusting the amplitude of the internal step function generator	stepfunction level	11
Current / voltage output for the valve command value with automatic changeover between $U_0 = 0 \text{ V to } \pm 10 \text{ V}$ or $I_0 = 0 \text{ mA to } \pm 20 \text{ mA}$		17
Short-circuiting links for the separation of individual cable strands in the connection from the control to the valve		14
Output measuring sockets for checking the signals in the valve connecting cable	A to F	12
Output socket AB: Connection on the valve side using an MS3108A-14S-6S flanged socket		16
Voltage converter DC/DC for the internal voltage supply		18

¹⁾ The item numbers refer to the unit drawing and block circuit diagram

Notes:

Operating mode without enable input

Valves with integral electronics and an operating voltage of + 24 V without enable input use connection C as reference potential for the actual valve value. In this case, the "enable" switch must be set to "off".

Operating mode with enable input

Valves with integral electronics and an operating voltage of + 24 V with enable input use connection B as reference potential for the actual valve value. In this case, the "enable" switch must be set to "on".

Overview of servo and proportional valves that can be tested

At the time of publicizing this data sheet, the following servo and proportional valves of Bosch Rexroth can be tested with the VT-VET-1-1X test unit:

Valve type	Operating voltage U_B
Servo-valve with integral electronics (OBE)	
4WSE2EM6 (without electrical position feedback)	± 15 V
4WSE2EM10(A)-4X (without electrical position feedback)	± 15 V
4WSE2EE10(A)-4X	± 15 V
4WSE2EM10-5X (without electrical position feedback)	± 15 V
4WSE2ED10-5X	± 15 V
4WSE2EM16(A) (without electrical position feedback)	± 15 V
4WSE2ED16(A)	± 15 V
4WSE3EE16	± 15 V
4WSE3EE25	± 15 V
4WSE3EE32	± 15 V
4DSE1EO2 (without electrical position feedback)	± 15 V
3DSE2EH10 (without electrical position feedback)	± 15 V
Proportional and high-response valves with integral electronics (OBE)	
4WRAE (without electrical position feedback)	+ 24 V
4WREE	+ 24 V
4WRPEH	+24 V
4WRSE(H)	+ 24 V
4WRKE	+ 24 V
4WRTE	+ 24 V
4WRGE	± 15 V or + 24 V
4WRDE	± 15 V or + 24 V
.WRCE	± 15 V or + 24 V
FESE (ab Serie 2X)	+ 24 V
3FERE	+ 24 V
.WRZE (without electrical position feedback)	+ 24 V
DBEE (without electrical position feedback)	+ 24 V
DBEME (without electrical position feedback)	+ 24 V
DBEMTE (without electrical position feedback)	+ 24 V
DBETE (without electrical position feedback)	+ 24 V
DBETRE (without electrical position feedback)	+ 24 V
ZDBEE (without electrical position feedback)	+ 24 V
STW on enquiry	± 15 V or + 24 V
DREE (without electrical position feedback)	+ 24 V

Accessories: Power supply units

Power supply unit type VT-VETNT-3-1X/G24

Desktop version 90-265 VAC → 24 VDC; 3.75 A



H 6847

Typ VT-VETNT-3-1X/G24

Technical Data (for applications outside these parameters, please consult us!)

Operating voltage	<i>U</i>	90-265 VAC; 47-63 Hz
Current consumption	<i>I</i>	max. 1.5 A
Fuse		Electronic overload protection
Output voltage	<i>U</i>	24 VDC ± 1 V; 3.75 A
Supply cable length	<i>l</i>	approx. 1.5 m
Cable length to test unit	<i>l</i>	approx. 1.5 m
Dimensions (W x H x D)		135 x 65 x 41 mm
Weight	<i>m</i>	0.4 kg

Power supply unit type VT-VETNT-2-1X/G15

Plug version 115 VAC / 230 VAC → ± 15 VDC; 0.25 A



H 6846

Typ VT-VETNT-2-1X/G15

Technical Data (for applications outside these parameters, please consult us!)

Operating voltage	<i>U</i>	115 V / 230 V ± 5 % 50/60 Hz can be changed over
Current consumption	<i>I</i>	< 29 mA
Fuse		Thermal link 130 °C
Output voltages	<i>U</i>	+ 15 VDC ± 0.2 V; 0.25 A - 15 VDC ± 0.2 V; 0.25 A
Cable length to the test unit	<i>l</i>	2 m
Dimensions (W x H x D)		86 x 56 x 86 mm
weight	<i>m</i>	0.63 kg

Accessories: Connecting and adapter cables

Connecting cable type VT-VETK-1-1X

Connecting cable between the VT-VET-1-1X test unit and servo and proportional valves with integral electronics (valves with the electrical connection ordering codes K9 and K31)

Technical data (for applications outside these parameters, please consult us!)

Valve connection		Plug-in connector to DIN EN 175201-804
Test unit connection		Plug MS3101A 14S 6P
Connecting cable length	<i>l</i>	3 m
Weight	<i>m</i>	0.3 kg

Notes:

To achieve greater lengths, several cables can be joined together.

When operating valves with an electrical connection K31, the earth is interrupted.

Adapter cable type VT-VETAK-1-1X

Adapter cable between the VT-VET-1-1X test unit and servo and proportional valves with integral electronics (valves with electrical connection ordering code K17).

Technical data (for applications outside these parameters, please consult us!)

Valve connection		Plug-in connector VG 95328
Test unit connection		Plug MS3101A 14S 6P
Connecting cable length	<i>l</i>	3 m
Weight	<i>m</i>	0.3 kg

Notes

Bosch Rexroth AG
Hydraulics
Zum Eisengiesser 1
97816 Lohr am Main, Germany
Telephone +49 (0) 93 52 / 18-0
Fax +49 (0) 93 52 / 18-23 58
documentation@boschrexroth.de
www.boschrexroth.de

© This document, as well as the data, specifications and other information set forth in it, are the exclusive property of Bosch Rexroth AG. It may not be reproduced or given to third parties without its consent. The data specified above only serve to describe the product. No statements concerning a certain condition or suitability for a certain application can be derived from our information. The information given does not release the user from the obligation of own judgment and verification. It must be remembered that our products are subject to a natural process of wear and aging.