

Electric amplifiers for proportional valves

RE 30109/07.05

1/6

Type VT-VSPA1

Unit series 1X

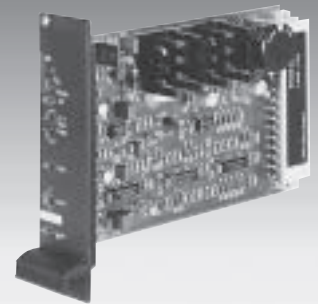

List of contents

Contents

Features
Ordering data
Preferred types
Front panel
Circuit diagram
Technical data
Unit dimensions

Features

Page	
1	– Analog amplifier in Europe card format for installation in 19" subrack
2	– Differential input for setpoint voltage 0...+10 V
2	– Ramp generator with separate adjustment for up and down
3	– Zero potentiometer
4	– Closed-loop-controlled output stage
5	– LED display:
6	• Voltage supply
	• On standby
	• Ramp "Off"
	• Solenoid current $I_M = 0$

Testing and service equipment

- Test box type VT-PE-TB1, see RE 30063
- Test adapter type VT-PA-3, see RE 30070

Ordering data

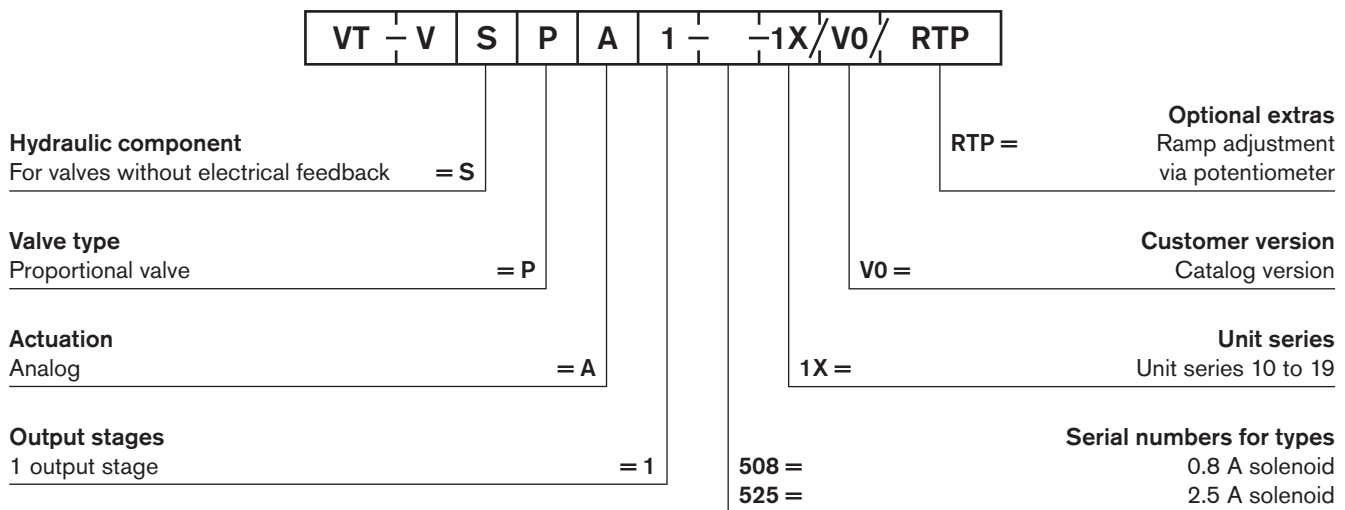

Preferred types

Type	Material Number	For valve types
VT-VSPA1-525-10/V0/RTP	0 811 405 079	see valve group A
VT-VSPA1-508-10/V0/RTP	0 811 405 081	see valve group B

Valve group A

DBETX-...-25
DBE6X-...-25
DRE6X-...-25
DBE10Z-...-25
DRE10Z-...-25
2FREX6
2FREX10
3FREX6
3FREX10
4WRBA..EA

Valve group B

DBETX-...-8
DBE6X-...-8
DRE6X-...-8
DBE10Z-...-8
DRE10Z-...-8

Front panel

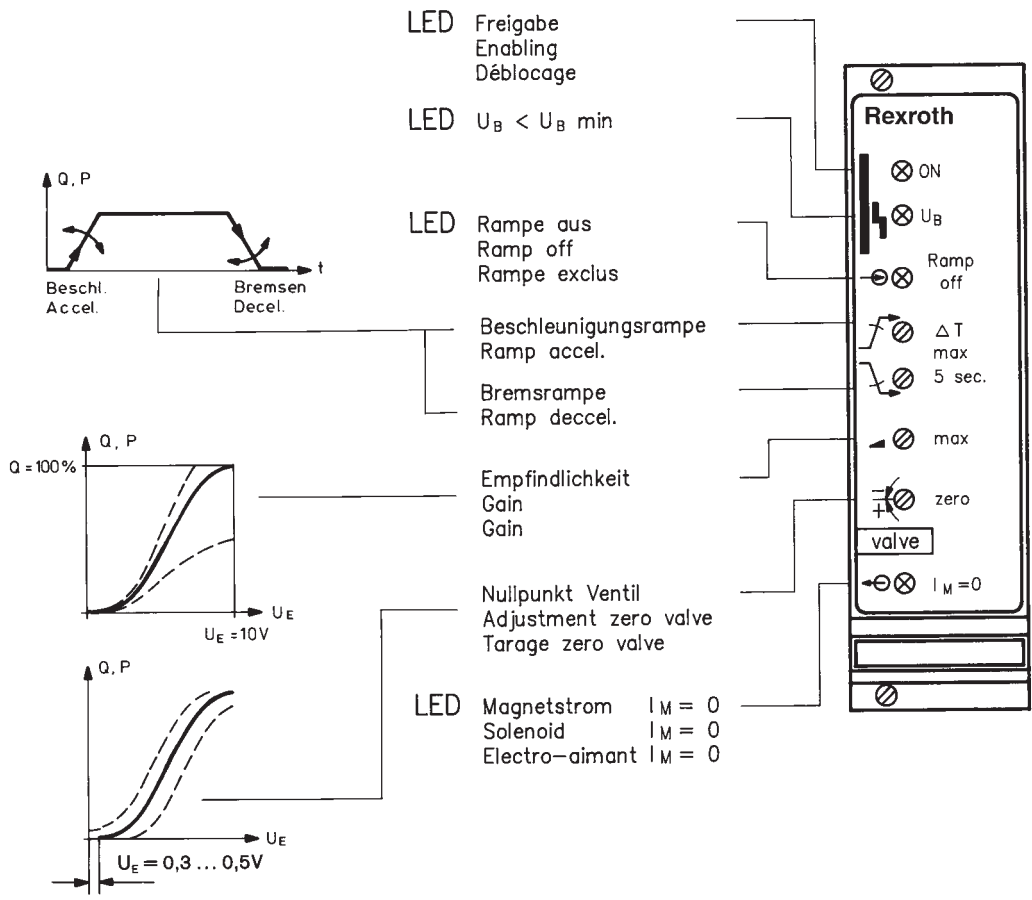

Technical data

Specifications		
P.C.B. format	mm	(100 x 160 x approx. 35)/(W x L x H) Europe card format with front panel with 7 modular spacings
Plug connector		Plug DIN 41612-F32
Ambient temperature	°C	0...+70, storage temperature min. -20; max. +70
Power supply		24 V DC nominal battery voltage 21...40 V, rectified AC voltage $U_{\text{eff}} = 21...28 \text{ V}$ (single-phase, full-wave rectification)
Current rating		0811 405 079 max. 1.5 A (NG6)/max. 2.5 A (NG10) 0811 405 081 max. 1.25 A
Power consumption		0811 405 079 max. 35 VA (NG6)/max. 60 VA (NG10) 0811 405 081 max. 30 VA
Setpoint potentiometer		$R_L \geq 1 \text{ k}\Omega$ Supply: b/z 32, +10 V/20 mA
Input signals		b10: +10 V z10: +10 V z16: +10 V } Differential z18: Diff. 0 V } input
External ramp shut-off		b20: 6...40 V= (nom. 10 V DC)
Ramp monitor signal		z20: 0...10 V
Cable lengths and cross-sections		Solenoid: < 20 m 1.5 mm ² 20...50 m 2.5 mm ²
Special features		Short-circuit-proof inputs and outputs Clocked output stage Rapid energizing for fast response times
LED displays		Yellow: ramp OFF Yellow: solenoid current $I_M = 0$ Green: U_B ON Red: $U_B < U_B \text{ min}$
Valve response time		50 ms with 100% signal change
Valve hysteresis	%	< 4
Ramp times	s	0.05...5
Adjustment possibilities		Valve zero, sensitivity, ramp times, dither amplitude

Caution!

Power zero b2 and control zero b12 must be jumpered.
If removing power pack, < 1 m directly to DIN plug.
If removing > 1 m route control zero separately to ground.

Notes for calibrating the P.C.B.s

Zero: A setpoint $U_E \sim 300 \text{ mV}$ is set as default for calibration.
Sensitivity (max.): A setpoint $U_E = 10 \text{ V}$ is set as default for calibration.

Notes on the use of ramps

Ramp UP (accelerate) and ramp DOWN (decelerate) are each set by a trimming potentiometer.

Ramp ON, if b20 open. **Ramp OFF**, if b20 $U > 6 \text{ V}$, e.g. 10 V from b22.

Ramp OFF interrupts a ramp in progress.

There is an abrupt transition to the final signal value.

Unit dimensions (nominal dimensions in mm)

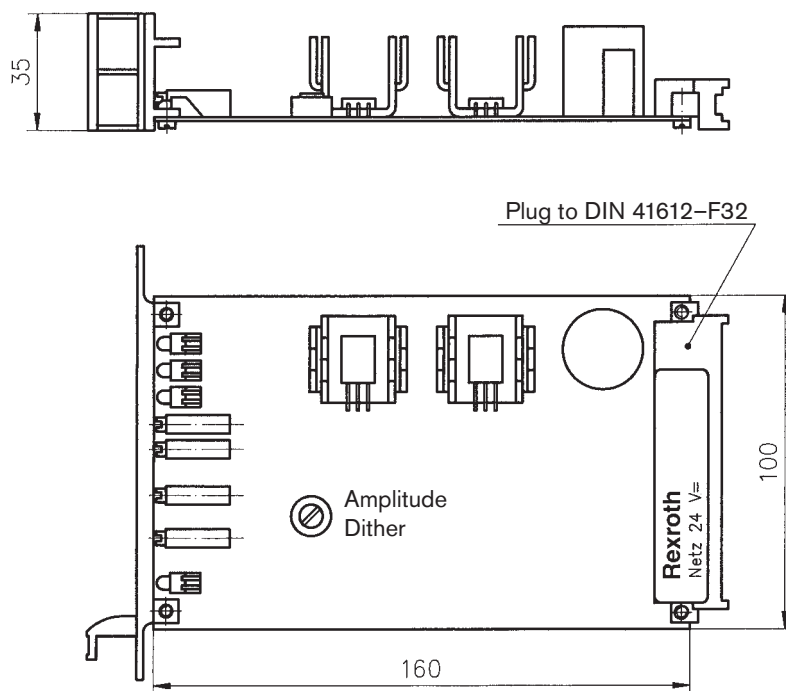

Notes

Bosch Rexroth AG
Hydraulics
Zum Eisengießer 1
97816 Lohr am Main, Germany
Telefon +49 (0) 93 52 / 18-0
Telefax +49 (0) 93 52 / 18-23 58
documentation@boschrexroth.de
www.boschrexroth.de

© This document, as well as the data, specifications and other information set forth in it, are the exclusive property of Bosch Rexroth AG. It may not be reproduced or given to third parties without its consent.

The data specified above only serve to describe the product. No statements concerning a certain condition or suitability for a certain application can be derived from our information. The information given does not release the user from the obligation of own judgement and verification. It must be remembered that our products are subject to a natural process of wear and aging.

Notes
