

# Directional servo-valve of 4-way design

**RE 29620/05.09**  
Replaces: 04.08

1/12

## Type 4WSE3E 16

Size 16  
Component series 2X  
Maximum operating pressure 350 bar  
Maximum flow 570 l/min

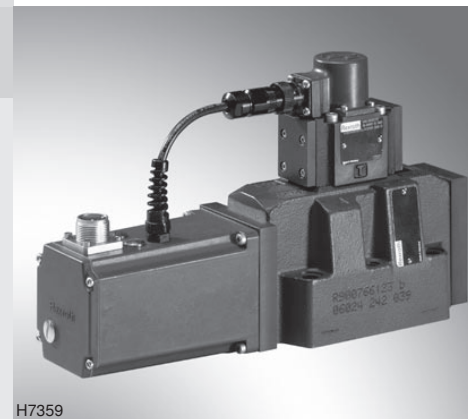

H7359

## Table of contents

Content	Page
Features	1
Ordering code	2
Symbol	2
Function, section	3
Technical data	4
Electrical connection	5 and 6
Characteristic curves	7 to 10
Unit dimensions	11
Flushing plate with porting pattern to ISO 4401	12

## Features

- Valve to control position, force, pressure, and velocity
- 3-stage servo-valve with electrical position control of the control spool of the 3rd stage, position sensing of the control spool by means of an inductive position transducer
- High-dynamics 2-stage pilot control valve of size 6
- 1st stage as nozzle flapper plate amplifier
- Filter for 1st stage externally accessible and replaceable
- For subplate mounting, porting pattern according to ISO 4401-07-07-0-05
- Can also be used as 3-way variant
- Valve and integrated control electronics are adjusted and tested in the factory
- Optimized valve control loop
- High response sensitivity, very low hysteresis and zero point drift
- Internal or external pilot oil supply and return
- Gap seals at pressure chambers of the control sleeve, no wear of O-ring

Information on available spare parts:  
[www.boschrexroth.com/spc](http://www.boschrexroth.com/spc)

## Ordering code

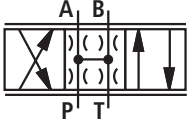
4WSE3E 16				-2X/ V		/		K31		*	
3-stage servo-valve										Further details in clear text	
Size 16 = 16										<b>Electronics interface</b> <b>Command/actual value</b> A1 = ±10 V C1 = ±10 mA Others on request	
<b>Control spool symbol</b> <sup>1)</sup>  = V = V1										<b>Electrical connection</b> K31 = 6+PE without mating connector	
<b>Control spool position when not energized</b> Not defined = No code 100 % P → A / B → T = P										<b>Supply voltage</b> 15 = ±15 V 24 = +24 V See page 5	
<b>Nominal flow</b> <sup>2)</sup> 105 l/min = 100 150 l/min = 150 200 l/min = 200 260 l/min = 300										<b>Pressure rating</b> <sup>6)</sup> 7 = 210 bar 9 = 315 bar	
<b>Control spool overlap</b> <sup>3)</sup> 0 to 0.5 % positive = D 0 to 0.5 % negative = E										<b>Pilot flow</b> <sup>5)</sup> XY = Pilot oil supply external, return external XT = Pilot oil supply external, return internal PY = Pilot oil supply internal, return external PT = Pilot oil supply internal, return internal	
Component series 20 to 29 (20 to 29: unchanged installation and connection dimensions) = 2X											
<b>Seal material</b> <sup>4)</sup> FKM seals = V suitable for mineral oil (HL, HLP) to DIN 51524											

### 1) Control spool symbols

with control spool symbol V

P → A;  $q_{V \max}$       B → T;  $q_{V \max}$   
 P → B;  $q_{V \max}$       A → T;  $q_{V \max}$

with control spool symbol V1

P → A;  $q_{V \max}$       B → T;  $q_{V \max} / 2$   
 P → B;  $q_{V \max} / 2$       A → T;  $q_{V \max}$

### 2) Nominal flow

The nominal flow refers to a command value signal of 100 % at a valve pressure differential of 70 bar (35 bar per control land). The valve pressure differential must be regarded as reference. Other values will result in a change in the flow.

Please note a possible nominal flow tolerance of ±10 % and a saturation influence (see flow/signal function on page 7).

### 3) Control spool overlap

The control spool overlap in % is referred to the nominal stroke of the control spool.

(Further control spool overlaps on request.)

### 4) Seal material

Other seal materials upon request!

### 5) Pilot oil

Care should be taken that the pilot pressure is as constant as possible. An external pilot control via port X is thus often advantageous.

### 6) Inlet pressure range

Care should be taken that the inlet pressure is as constant as possible.

Minimum pilot pressure ≥ 10 bar.

Up to a pilot pressure of 210 bar, pressure rating 7 is to be selected. For a pilot pressure of more than 210 bar, pressure rating 9 is to be selected.

Regarding the dynamics, the dependance on frequency must be observed within the admissible pressure rating.

At an inlet pressure > 40 bar, the pilot pressure must not be less than 60 % of the inlet pressure as otherwise, the flow forces acting on the control spool of the 3rd stage may affect the controllability.

At an inlet pressure of ≤ 40 bar it is in any case advantageous to work with a pilot pressure via port X (external supply).

## Symbol

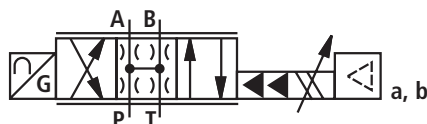

## Function, section

The valves of type 4WSE3E 16 are electrically operated 3-stage servo-valves with porting pattern according to ISO 4401. They are mainly used for controlling position, force or pressure and velocity.

These valves consist of a 2-stage pilot control valve of type 4WS2EM 6 (1), a main stage with a main control spool in a sleeve (3rd stage), an inductive position transducer, and integrated control electronics.

The pilot control valve (1) consists of an electro-mechanical converter (torque motor), a hydraulic amplifier (nozzle flapper plate principle) and a pilot control spool in a sleeve, which is connected to the torque motor via a mechanical feedback.

Electric currents in the coils of the torque motor generate a force by means of a permanent magnet which acts on the armature, and in connection with a torque tube results in a torque. This causes the flapper plate which is connected to the torque tube via a pin to move from the central position between the two control nozzles, and a pressure differential is created across the front faces of the pilot control spool. The pressure differential results in the control spool changing its position, which results in the pressure port being connected to one actuator port and, at the same time, the other actuator port being connected to the return flow port.

The pilot control spool is connected to the flapper plate or the torque motor by means of a bending spring (mechanical feedback).

The position of the control spool is changed until the flapper plate position and hence the pressure differential across the nozzle flapper plate system becomes zero due to the feedback torque, which acts via the bending spring against the electro-magnetic torque of the torque motor.

In doing so, the stroke of the pilot control spool and hence the flow of the pilot control valve is controlled proportionally to the electrical input signal (see RE 29564).

In the main stage, the main control spool (2) is operated by the pilot control valve and its position is sensed by an inductive position transducer (3). The position transducer signal is compared to the command value by integrated control electronics (4). Any possible control deviation is amplified electrically and fed to the pilot control valve as control signal. The pilot control valve starts to move and the main control spool is re-positioned.

The stroke of the main control spool and consequently the flow of the servo-valve are controlled in proportion to the command value. It must be noted that the flow depends on the valve pressure differential.

The valve zero point can be adjusted by means of an externally accessible potentiometer.

The valves are factory-set with a dither default setting with the constant frequency of 400 Hz.

**⚠ Changes in the zero point and/or the dither amplitude may result in damage to the system and may only be implemented by instructed specialists. Operating instructions are currently being developed.**

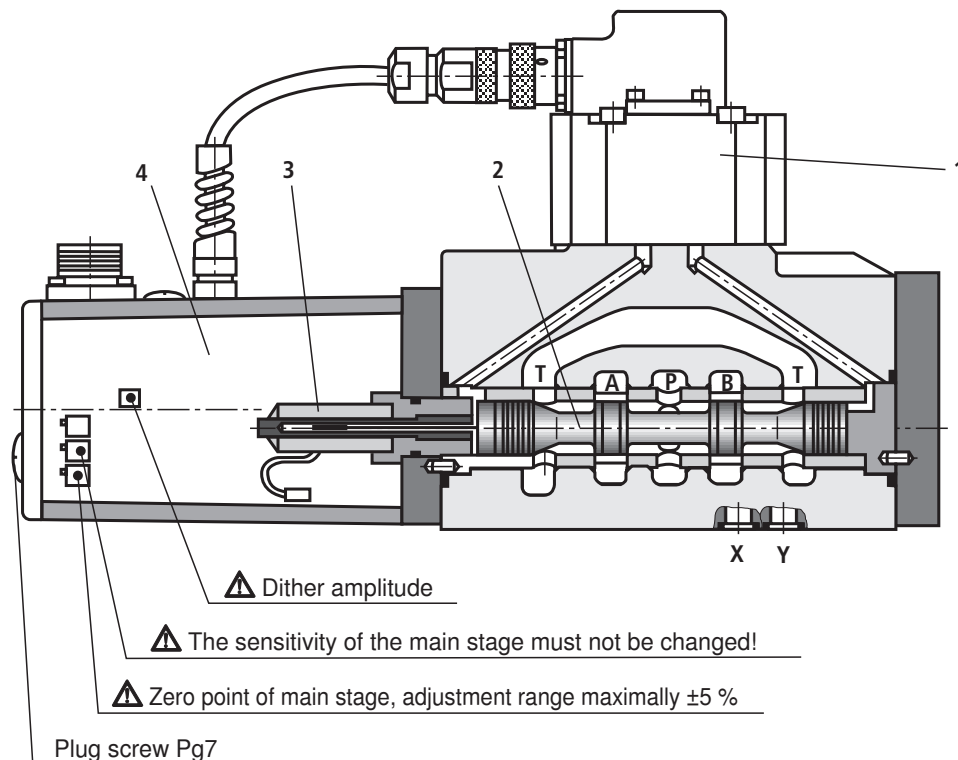

The pilot control valve may only be maintained by Bosch Rexroth employees. An exception to this is the replacement of the filter element – see RE 29564.

**Technical data** (for applications outside these parameters, please consult us!)

<b>general</b>		
Weight	kg	9,5
Installation position		Optional, if it is ensured that the pilot control is supplied with sufficient pressure (> 10 bar) during start-up of the system. In case of insufficient pressure supply, the control spool of the servo-valve can take any position. This may result in channel P being connected to the actuator and the build-up of pressure being delayed. This may be prevented by providing an external pressure supply at port X.
Storage temperature range	°C	-20 to +80
Ambient temperature range	°C	-20 to +60

**hydraulic** (measured with HLP 32,  $\vartheta_{oil} = 40 \text{ °C} \pm 5 \text{ °C}$ )

Operating pressure	Pilot control stage, pilot oil supply X	bar	10 to 210 and/or 10 to 315 (see page 2, pressure rating)
	Main valve, port P, A, B	Pilot oil supply internal bar	up to 315
	Main valve, port P, A, B	Pilot oil supply external bar	up to 350
Return flow pressure	Pilot control stage, port Y	bar	Pressure peaks < 100 permitted, static < 10
	Main valve, port T	Pilot oil return internal bar	Pressure peaks < 100 permitted, static < 10
		Pilot oil return external bar	up to 250
Leakage flow			See page 8 (characteristic curves)
Nominal flow $q_v \pm 10 \%$ at $\Delta p = 70 \text{ bar}^1$	l/min		105, 150, 200, 260
Hydraulic fluid			Mineral oil (HL, HLP) according to DIN 51524 <sup>2)</sup> ; other hydraulic fluids upon request
Hydraulic fluid temperature range	°C		-20 to +80; preferably +40 to +50
Viscosity range	mm <sup>2</sup> /s		15 to 380; preferably 30 to 45
Maximum permitted degree of contamination of the hydraulic fluid - cleanliness class according to ISO 4406 (c)	Pilot control valve		Class 18/16/13 <sup>3)</sup>
	Main stage		Class 20/18/15 <sup>3)</sup>
Hysteresis	%		≤ 0.10
Range of inversion	%		≤ 0.05
Response sensitivity	%		≤ 0.05
Pressure gain			≥ 90 % of $p_p$ <sup>4)</sup> with 1 % change in the control spool stroke (from hydraulic zero point)
Zero drift upon change of:	Hydraulic fluid temperature	% / 10 K	≤ 0.3
	Ambient temperature	% / 10 K	≤ 0.3
	Operating pressure	% / 100 bar	≤ 0.3
	Return flow pressure		
	0 to 10 % of $p_p$	% / 100 bar	≤ 0.3

**electrical**

Type of protection according to EN 60529	IP 65 with mating connector mounted and locked
Type of signal	Analog

<sup>1)</sup>  $\Delta p$  = Valve pressure differential in bar<sup>2)</sup> Suitable only for FKM seals<sup>3)</sup> The cleanliness classes specified for the components must be adhered to in hydraulic systems. Efficient filtration prevents malfunctions and simultaneously increases the lifetime of the components.  
For the selection of filters, see data sheets RE 50070, RE 50076 and RE 50081.<sup>4)</sup>  $p_p$  = Inlet pressure/operating pressure **Note!**

For information on the **environment simulation testing** for the areas EMC (electromagnetic compatibility), climate and mechanical load, see RE 29620-U.

## Electrical connection

### Pinout / block circuit diagram of the integrated electronics (OBE)

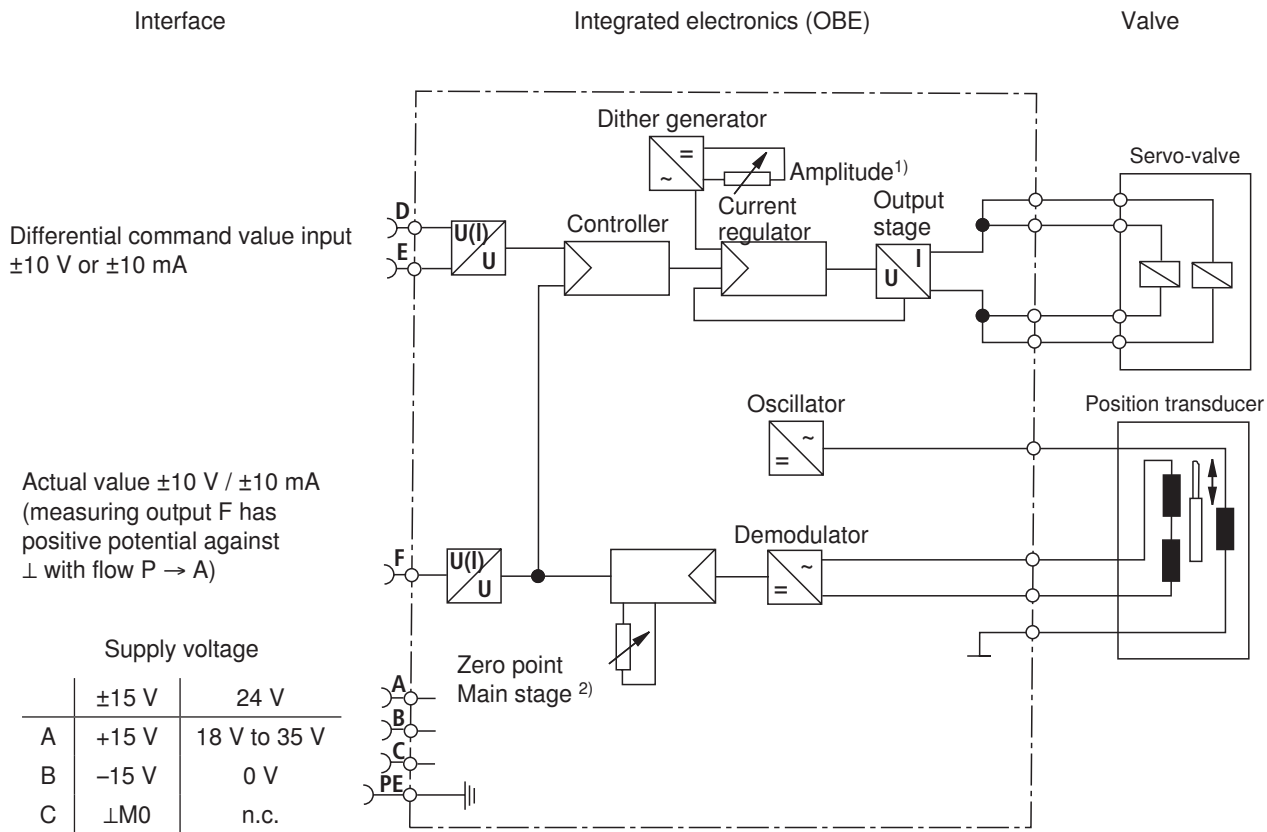

**⚠ One end of the shield must be connected to the control!**

1) 2)

**⚠ Changes in the zero point and/or the dither amplitude may result in damage to the system and may only be implemented by instructed specialists.**

## Electrical connection (continued)

### Integrated control electronics

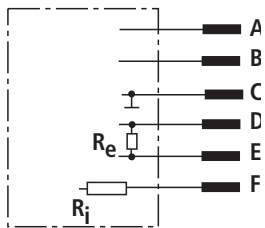

Electronics interface		A1	C1
Current requirement at mating connector	Pin		
	A	< ±150 mA at ±15 V	
	B	< 200 mA at 24 V	
	D	0 to ±0.05 mA	0 to ±10 mA
	E		

Connector pinout	Pin	Supply voltage 15		Supply voltage 24	
		A1	C1	A1	C1
Interface					
Supply voltage	A	+15 VDC		+24 VDC	
	B	-15 VDC		0 VDC	
M0	C	0 VDC / reference to pins A, B		Not assigned	
Differential command value input	D	0 to ±10 V	0 to ±10 mA	0 to ±10 V	0 to ±10 mA
	E	$R_i > 100 \text{ k}\Omega$	$R_i = 100 \Omega$	$R_i > 100 \text{ k}\Omega$	$R_i = 100 \Omega$
Actual value					
Reference at +24 V is pin B	F	0 to ±10 V	0 to ±10 mA	0 to ±10 V	0 to ±10 mA
Reference at ±15 V is pin C		$R_i \approx 1 \text{ k}\Omega$	Load max. 1 kΩ	$R_i \approx 1 \text{ k}\Omega$	Load max. 1 kΩ
Protective earth	PE	Connected to valve housing			

**⚠ One end of the shield must be connected to the control!**

#### Supply voltage:

±15 V ±3 %, residual ripple content < 1 %  
 +24 VDC / 18 V to 35 V; full bridge rectification with smoothing capacitor  
 $2200 \mu\text{F} = I_{\text{max}} = 230 \text{ mA}$

#### Command value:

Positive signal  $D > E$  means direction of flow  $P \rightarrow A / B \rightarrow T$   
 Negative signal  $E > D$  means direction of flow  $P \rightarrow B / A \rightarrow T$

#### Actual value / measuring output:

The voltage / current signal is proportional to the control spool stroke.  
 With a positive signal, F against C also results in a positive signal (variant ±15 V)  
 With a positive signal, F against B also results in a positive signal (variant +24 V)

#### Note:

**Electric signals brought out via control electronics (e.g. actual value) must not be used for switching off safety-relevant machine functions!**

**(See also the European standard "Safety requirements for fluid power systems and their components – Hydraulics", EN 982!)**

**Mating connector** according to EN 175201-804  
 separate order under material no. **R900223890**

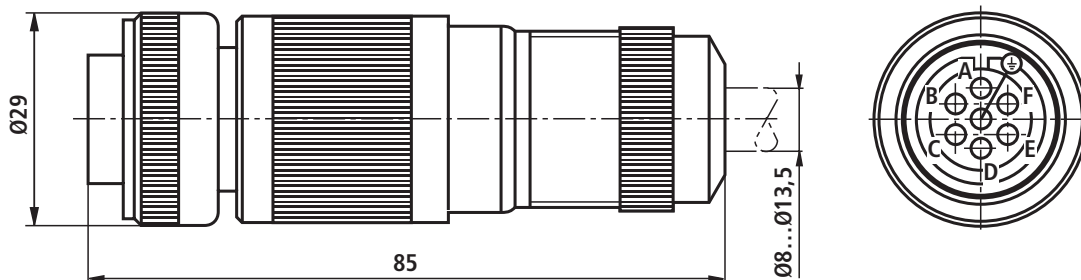

**Characteristic curves** (measured with HLP46,  $\vartheta_{oil} = 40 \text{ }^\circ\text{C} \pm 5 \text{ }^\circ\text{C}$ )

Flow/load function (tolerance  $\pm 10 \%$ ) at 100 % command value signal

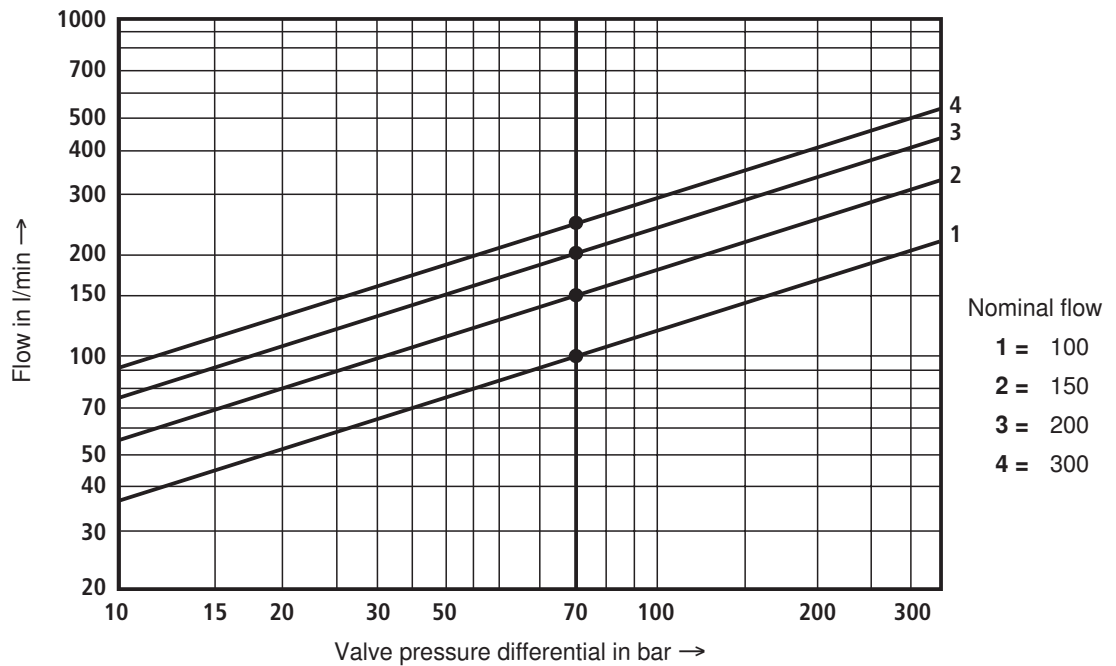

$\Delta p$  = valve pressure differential (inlet pressure  $p_p$  minus load pressure  $p_L$  minus return flow pressure  $p_T$ )

**Tolerance field of the flow/signal function** at constant valve pressure differential

Both control edges  $\Delta p_V = 70 \text{ bar}$

Single control edge  $\Delta p_V = 35 \text{ bar}$  (tolerance  $\pm 5 \%$ )

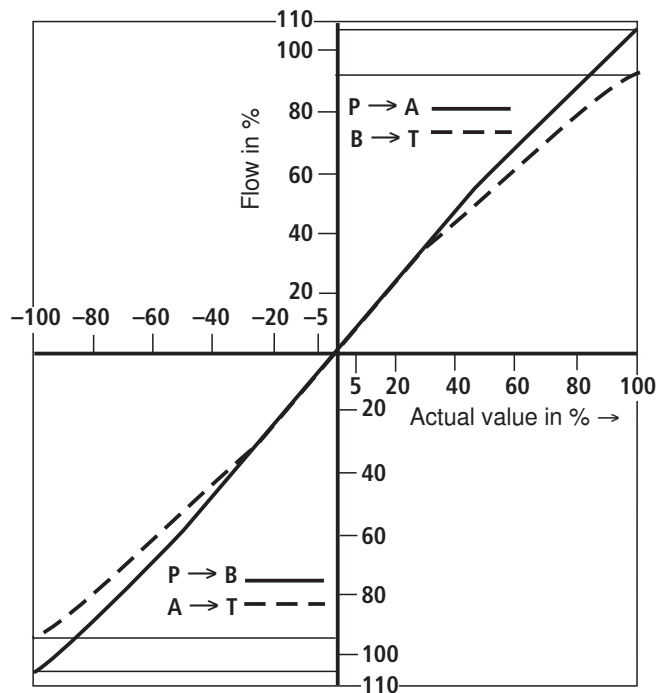
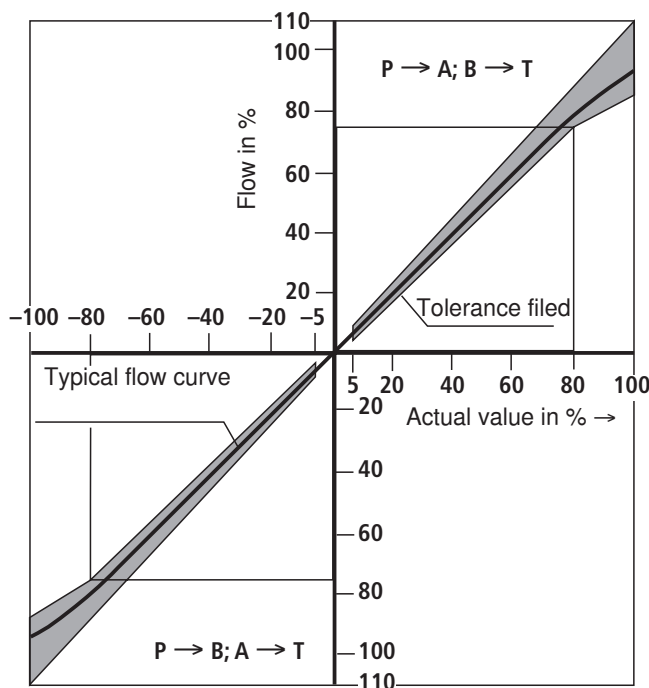

**Characteristic curves** (measured with HLP32,  $\vartheta_{oil} = 40 \text{ }^\circ\text{C} \pm 5 \text{ }^\circ\text{C}$ )

**Pressure signal characteristic curve**

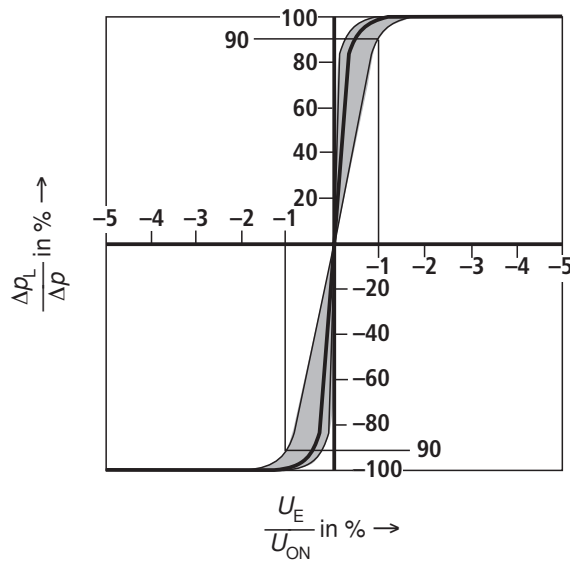

Measured at  
280 bar operating pressure

**Total leakage flow with “D” overlap (pilot valve and main stage)**

Tolerance  $\pm 20 \%$

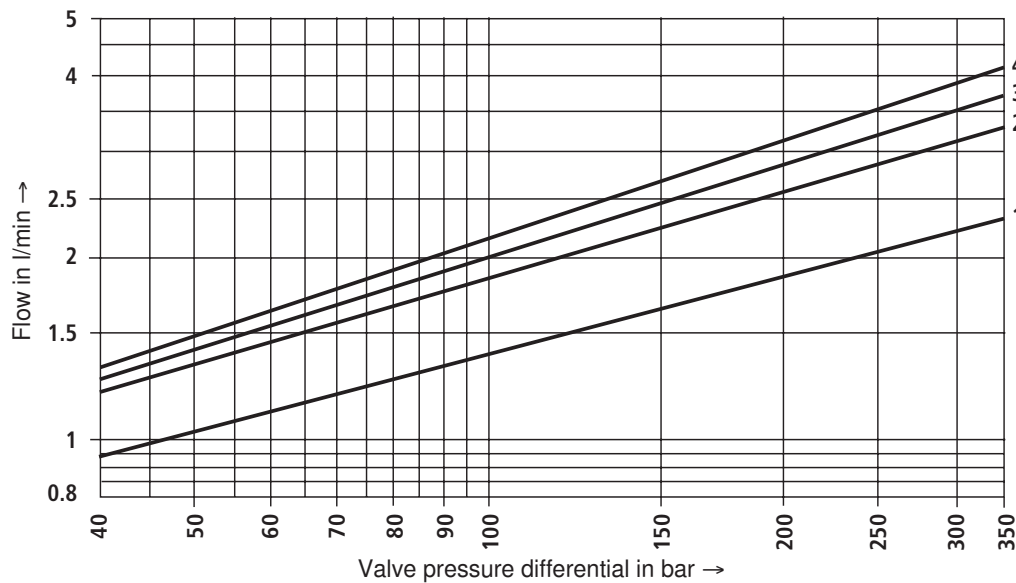

- 1 = 100
- 2 = 150
- 3 = 200
- 4 = 300

Leakage flow	Pilot control valve L1	l/min	$\leq \sqrt{\frac{p_P}{70 \text{ bar}}} \cdot 0.5$
Data valid for overlap “E”	Complete valve $q_V$	l/min	$\leq L1 + \sqrt{\frac{p_P}{70 \text{ bar}}} \cdot 0.015 \cdot q_{Vnom}$

$q_{Vnom}$  Nominal flow (complete valve) in l/min  
105, 150, 200, 260

$\Delta p$  Valve pressure differential in bar

$q_V$  100, 150, 200, 300 l/min

$p_P$  Operating pressure in bar

**Characteristic curves** (measured with HLP32,  $\vartheta_{oil} = 40 \text{ }^\circ\text{C} \pm 5 \text{ }^\circ\text{C}$ )

**Transient function – measured with 210 bar pressure rating**

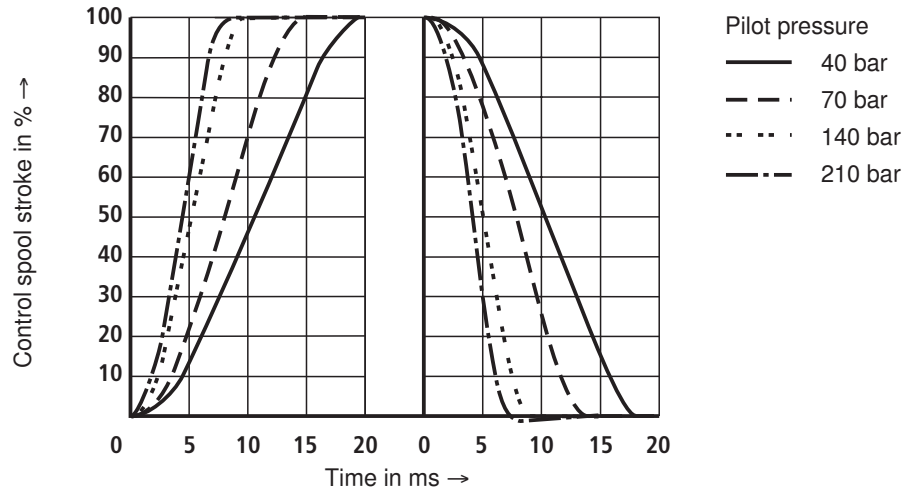

**Frequency response at  $p_p = 210 \text{ bar}$  – measured with 210 bar pressure rating**

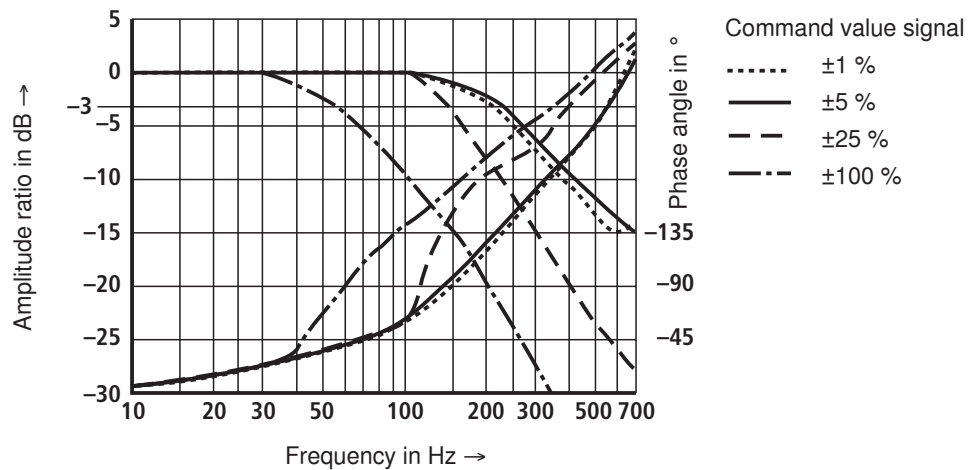

**Dependence of  $-90^\circ$  frequency on pilot pressure – measured with 210 bar pressure rating**

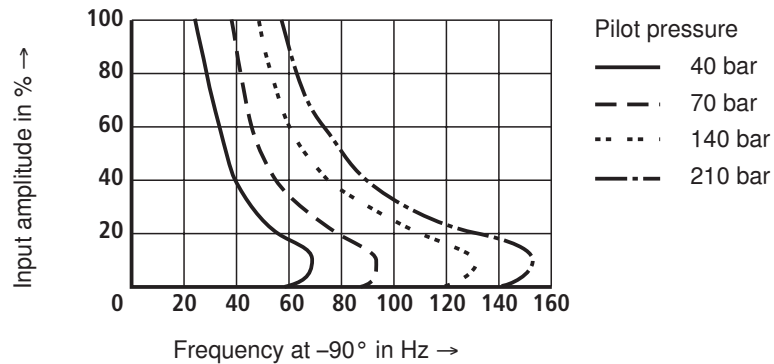

**Characteristic curves** (measured with HLP32,  $\vartheta_{oil} = 40 \text{ }^\circ\text{C} \pm 5 \text{ }^\circ\text{C}$ )

**Transient function – measured with 315 bar pressure rating**

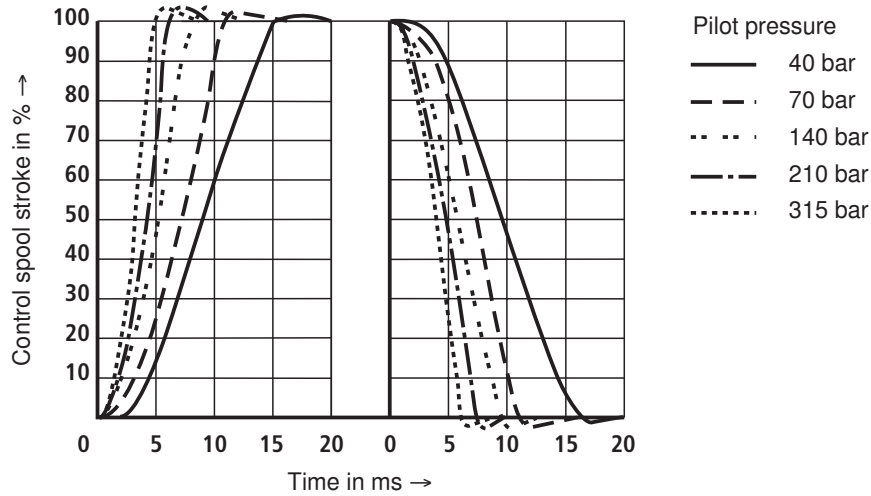

**Frequency response at  $p_p = 315 \text{ bar}$  – measured with 315 bar pressure rating**

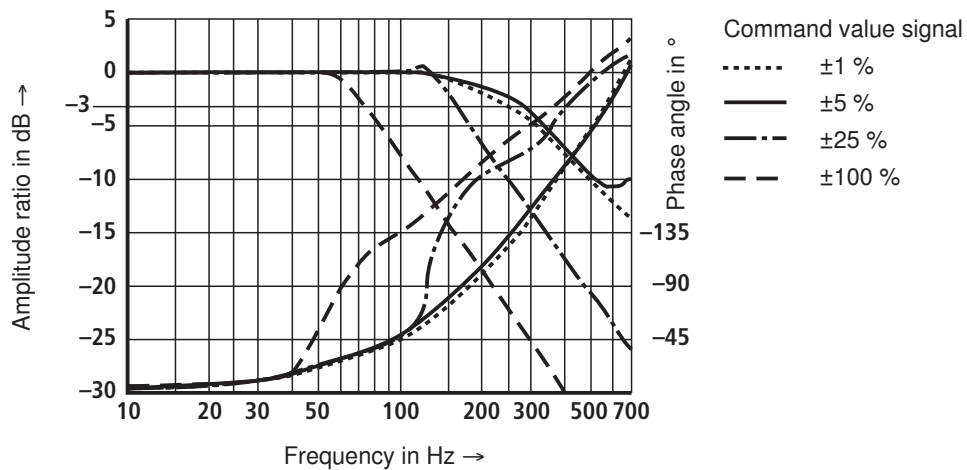

**Dependence of  $-90^\circ$  frequency on pilot pressure – measured with 315 bar pressure rating**

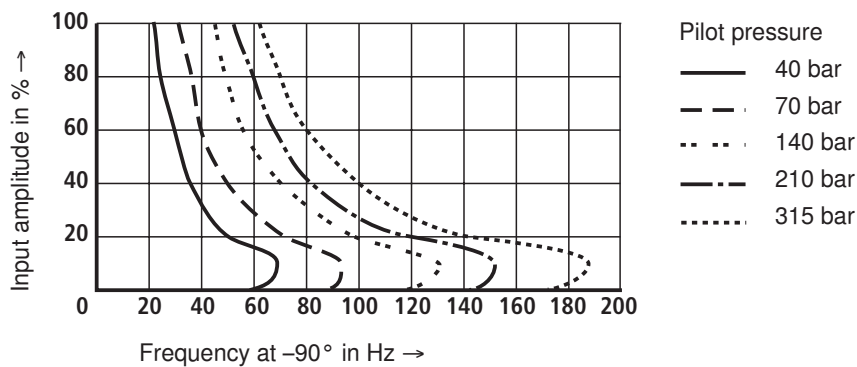

Output signal corresponds to control spool stroke without flow

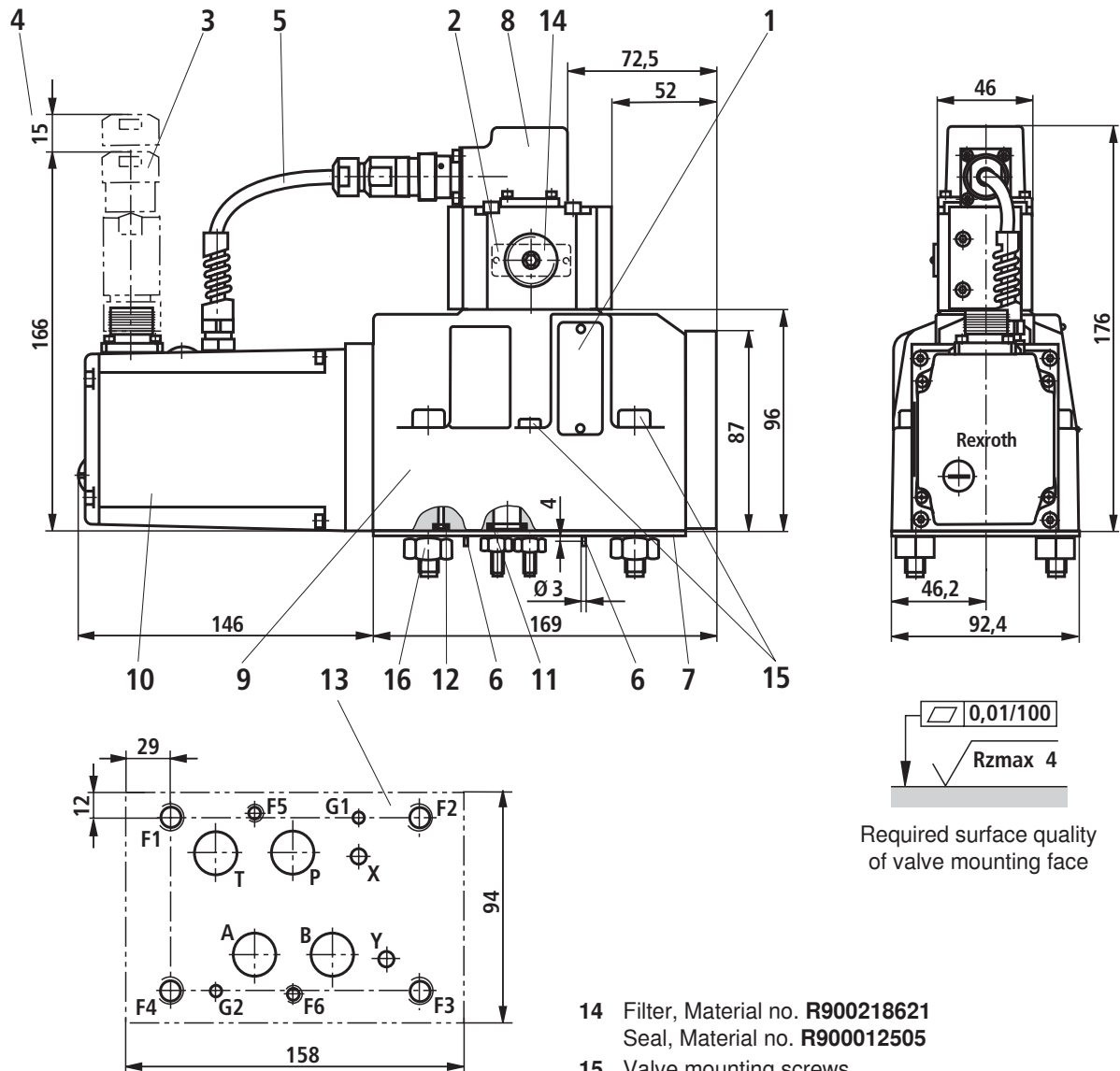
**Unit dimensions:** Subplate mounting with directional spool valve (dimensions in mm)

Required surface quality  
of valve mounting face

- 1 Nameplate – complete valve
- 2 Nameplate – pilot control valve
- 3 Mating connector to EN 175201-804, separate order, see page 6
- 4 Space required to remove mating connector, take account of connection cable!
- 5 PVC cable not resistant when in contact with HFD-R fluid
- 6 Locating pins (2 pcs) G1 and G2
- 7 Cover plate (for transport only)
- 8 Pilot control valve (2-stage)
- 9 Main stage (3rd stage)
- 10 Integrated control electronics
- 11 Identical seal rings for ports A, B, P and T
- 12 Identical seal rings for ports X and Y  
Ports X and Y are also pressurized with “internal” pilot oil
- 13 Machined valve mounting face, porting pattern to ISO 4401-07-07-0-05

- 14 Filter, Material no. **R900218621**  
Seal, Material no. **R900012505**
- 15 Valve mounting screws  
(included in the scope of supply)  
**2 hexagon socket head cap screws ISO4762-M6x60-10.9fZn-240-L**  
(Friction coefficient 0.09 to 0.14 to VDA235-101)  
Tightening torque  $M_T = 14 \text{ Nm} \pm 20 \%$   
Material no. **R913000115**  
**4 hexagon socket head cap screws ISO4762-M10x60-10.9fZn-240-L**  
(Friction coefficient 0.09 to 0.14 to VDA235-101)  
Tightening torque  $M_T = 58 \text{ Nm} \pm 20 \%$   
Material no. **R913000116**
- 16 Hexagon nuts (for transport only)

**Subplates** to data sheet RE 45056

- (separate order):
- |         |           |
|---------|-----------|
| G172/01 | (G3/4)    |
| G172/02 | (M27 x 2) |
| G174/01 | (G1)      |
| G174/02 | (M33 x 2) |
| G174/08 | (flange)  |

**Flushing plate with porting pattern to ISO 4401-07-07-0-05 (dimensions in mm)**

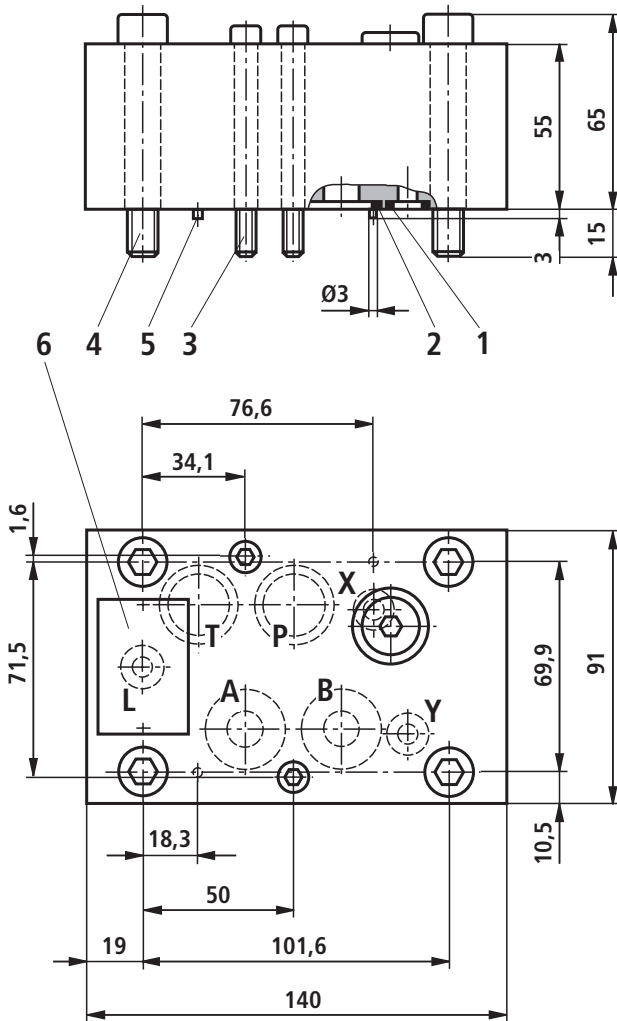

- 1 R-ring 10 x 2 x 2 (L, X, Y) included in the scope of supply
- 2 R-ring 22.53 x 2.30 x 2.62 (P, T, A, B) included in the scope of supply
- 3 2 hexagon socket head cap screws (included in the scope of supply)  
ISO4762-M6x70-10.9fZn-240h-L  
(Friction coefficient 0.09 to 0.14 to VDA 235-101)  
 $M_T = 15.5 \text{ Nm} \pm 20 \%$   
Material no. **R913000282**
- 4 4 hexagon socket head cap screws (included in the scope of supply)  
ISO4762-M10x70-10.9fZn-240h-L  
(Friction coefficient 0.09 to 0.14 to VDA 235-101)  
 $M_T = 75 \text{ Nm} \pm 20 \%$   
Material no. **R913000126**
- 5 2 locating pins 3 x 8 - A2C DIN EN 28741
- 6 Nameplate

To ensure proper functioning of the servo-valve, it is indispensable to flush the system before commissioning.

The following value can be used as a guideline for the flushing time per system:

$$t \geq \frac{V}{q_v} \cdot 5$$

$t$  = flushing time in hours  
 $V$  = tank capacity in liters  
 $q_v$  = pump flow in liters per minute

When topping up more than 10 % of the tank capacity, repeat the flushing process.

Better than a flushing plate is the use of a directional valve with port according to ISO 4401-07-07-0-05. This valve can also be used for flushing actuator ports.

**Symbols**



With FKM seals  
Material no. **R900904218**  
Weight: 4.75 kg

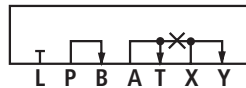

With FKM seals  
Material no. **R900959376**  
(not shown.)  
Weight: 4.5 kg