

4/3, 4/2 and 3/2 directional valve with wet-pin AC or DC solenoids

RE 23327/08.08
Replaces: 02.03

1/14

Type WE

Size 10
Component series 3X; 4X
Maximum operating pressure 315 bar [4569 psi]
Maximum flow 120 l/min [31.7 US gpm]

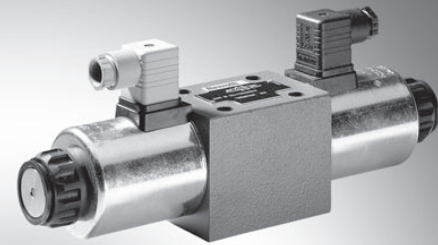

H5958

Table of contents

Content	Page
Features	1
Ordering code	2, 3
Mating connectors	3
Spool symbols	4
Function, section	5
Technical data	6, 7
Characteristic curves	8
Performance limits	9, 10
Unit dimensions	11 to 13

Features

- Direct operated directional spool valve with solenoid actuation in heavy-duty design
- Porting pattern to ISO 4401-05-04-0-05 and NFPA T3.5.1 R2-2002 D05
- Subplates, see data sheet RE 45054 (separate order)
- Wet-pin DC or AC solenoids with detachable coil
- Solenoid coil can be rotated 90°
- The pressure-tight chamber needs not to be opened for changing the coil
- Electrical connection as individual or central connection
- Manual override, optional
- Smoothly switching version, see RE 23183
- Inductive position switches and proximity sensors (contactless), see RE 24830
- For further electrical connections, see RE 08010

Notes on available spare parts:
www.boschrexroth.com/spc

Ordering code

	WE	10	/	C				
3 main ports								
4 main ports								
Size 10								
Spool symbols e.g. C, E, EA, EB, etc.; for possible versions, see page 4								
Component series 30 to 39 – individual connection (30 to 39: unchanged installation and connection dimensions)								
Component series 40 to 49 – central connection (40 to 49: unchanged installation and connection dimensions)								
With spring return								
Without spring return								
Without spring return with detent								
(Wet-pin) solenoid with detachable coil								
DC voltage 24 V								
AC voltage 230 V 50/60 Hz								
DC voltage 205 V								
For further ordering codes for other voltages and frequencies, see page 7								
With concealed manual override (standard)								
With manual override								
Without manual override								
Electrical connection ²⁾								
individual connection								
Without mating connector with component plug DIN EN 175301-803								
Central connection								
Cable entry on cover, with indicator lamp								
Central plug-in connection on cover, with indicator lamp (without mating connector)								
For further electrical connections, see RE 08010								

¹⁾ For connection to the AC voltage mains a DC solenoid **must** be used, which is controlled via a rectifier, (see table below).

In the case of individual connection, a large mating connector with integrated rectifier can be used (separate order).

²⁾ Also available with M12x1 plug-in connection (version "G24" only), see RE 08010

³⁾ Mating connectors, separate order, see page 3.

⁴⁾ Mating connector, separate order, Material no. **R900005538**

Standard types and components are shown in the EPS (standard price list).

AC voltage mains (permissible voltage tolerance $\pm 10\%$)	Nominal voltage of the DC voltage solenoid when operated with AC voltage	Ordering code
110 V - 50/60 Hz	96 V	G96
120 V - 60 Hz	110 V	G110
230 V - 50/60 Hz	205 V	G205

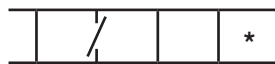

Further details in clear text

Seal material

NBR seals

FKM seals

(other seals on request)

Attention!

Observe compatibility of seals with hydraulic fluid used!

No code =
V =

No code =

B08 =

B10 =

B12 =

Use in the case of flows that exceed the performance limit of the valve; effective in channel P (see page 5).

Without Throttle insert

Throttle Ø 0.8 mm [0.031 inch]

Throttle Ø 1.0 mm [0.039 inch]

Throttle Ø 1.2 mm [0.047 inch]

Spool position monitoring

Without limit switch

Monitored spool position "a"

Monitored spool position "b"

Monitored rest position

For further details, see RE 24830

No code =

QMAG24 =

QMBG24 =

QM0G24 =

Mating connectors to DIN EN 175301-803

For details and further mating connectors, see RE 08006

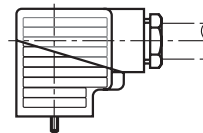
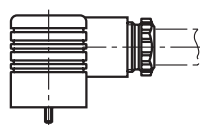

Conne- ction	Valve side	Color	Material number				
			Without circuitry	With indicator lamp 12 ... 240 V	With indicator lamp and rectifier 12 ... 240 V	With rectifier 12 ... 240 V	With indicator lamp and Zener-diode suppressor circuit 24 V
M16 x 1.5	a	Gray	R901017010	-	-	-	-
	b	Black	R901017011	-	-	-	-
	a/b	Black	-	R901017022	R901017029	R901017025	R901017026
1/2" NPT (Pg 16)	a	Red/ brown	R900004823	-	-	-	-
	b	Black	R900011039	-	-	-	-
	a/b	Black	-	R900057453	R900057455	R900842566	-

Spool symbols

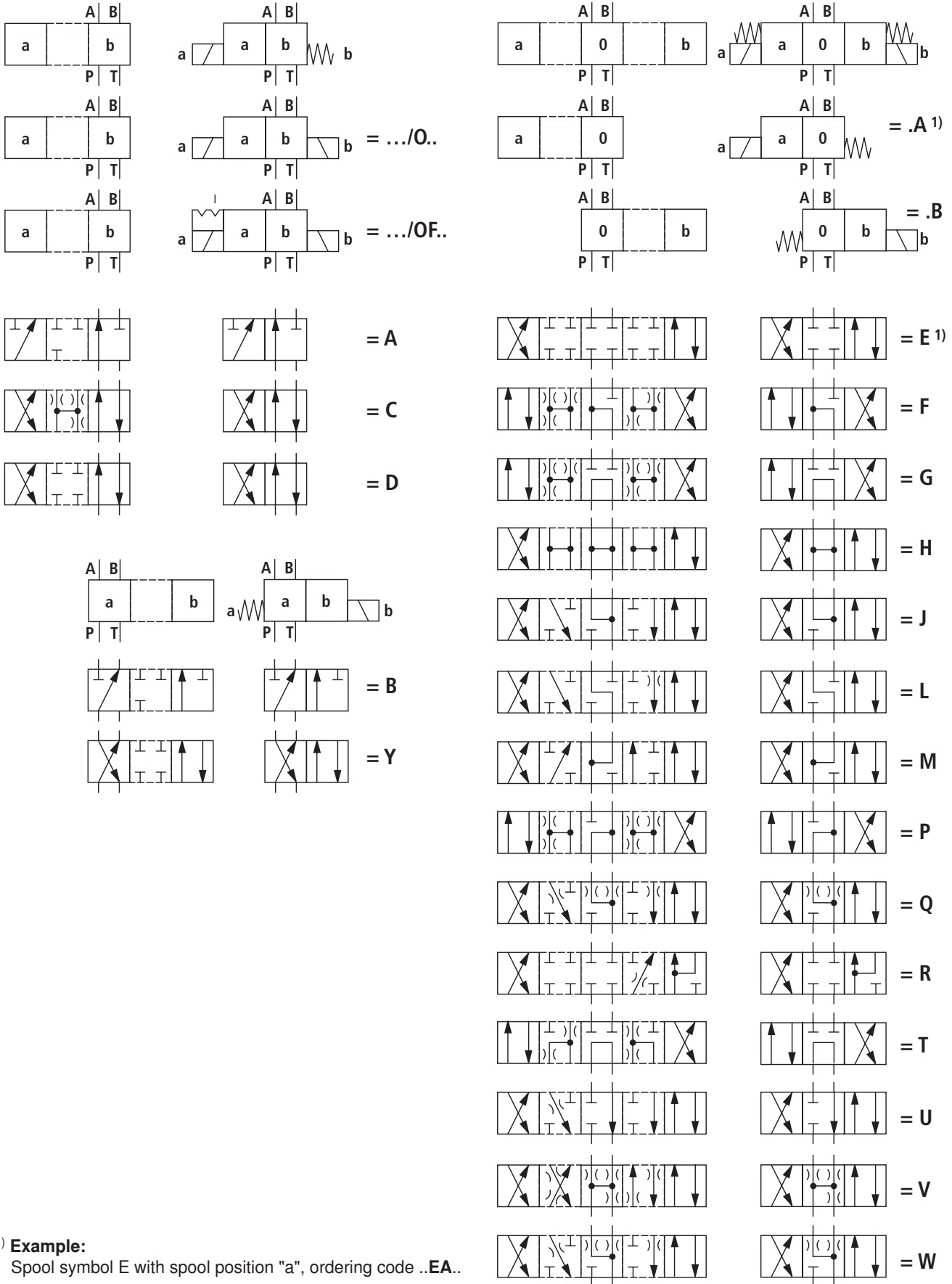

¹⁾ **Example:**
Spool symbol E with spool position "a", ordering code ..EA..

Function, section

Directional valves of type WE are solenoid operated directional spool valves. They control the start, stop and direction of a flow.

These directional valves basically consist of housing (1), one or two solenoids (2), control spool (3), as well as one or two return springs (4).

In the non-operated condition, control spool (3) is held by return springs (4) in the central position or the initial position (except for impulse spool). Control spool (3) is actuated by wet-pin solenoids (2).

To ensure proper functioning, care must be taken that the pressure chamber of the solenoid is filled with oil.

The force of solenoid (2) acts via plunger (5) on control spool (3) and pushes it from its rest position to the desired end position. As a result of this, the required direction of flow from P to A and from B to T or P to B and A to T opens.

After solenoid (2) was de-energized, control spool (3) is returned to its rest position by return spring (4).

An optional manual override (6) allows control spool (3) to be operated without energization of the solenoid.

Type .WE 10 ..O... (only possible with symbols A, C and D)

This version is a directional valve with two spool positions and two solenoids without detent. There is no defined spool position in the de-energized condition.

Type .WE 10 ..OF... (impulse spool, only possible with symbols A, C and D)

This version is a directional valve with two spool positions and two solenoids and a detent. It alternately holds both spool positions, and a permanent energization of the solenoid is therefore not required.

Note!

In conjunction with valves with detent, pressure peaks in the tank line to two or more valves can cause unwanted spool movements! We recommend that separate return lines be provided or a check valve installed in the tank line.

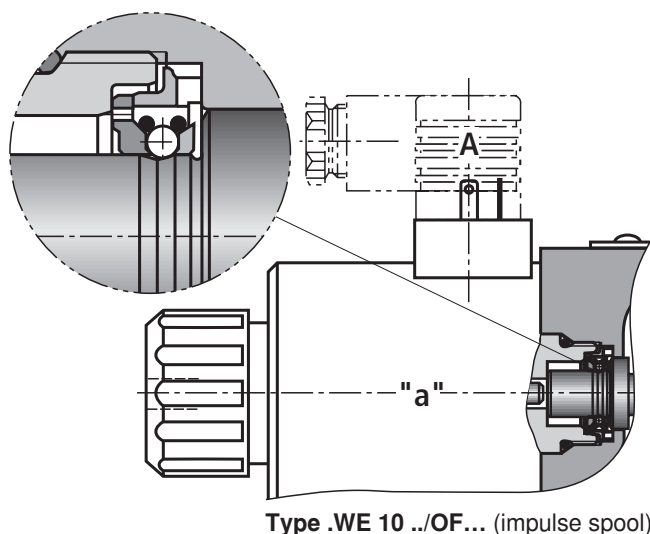
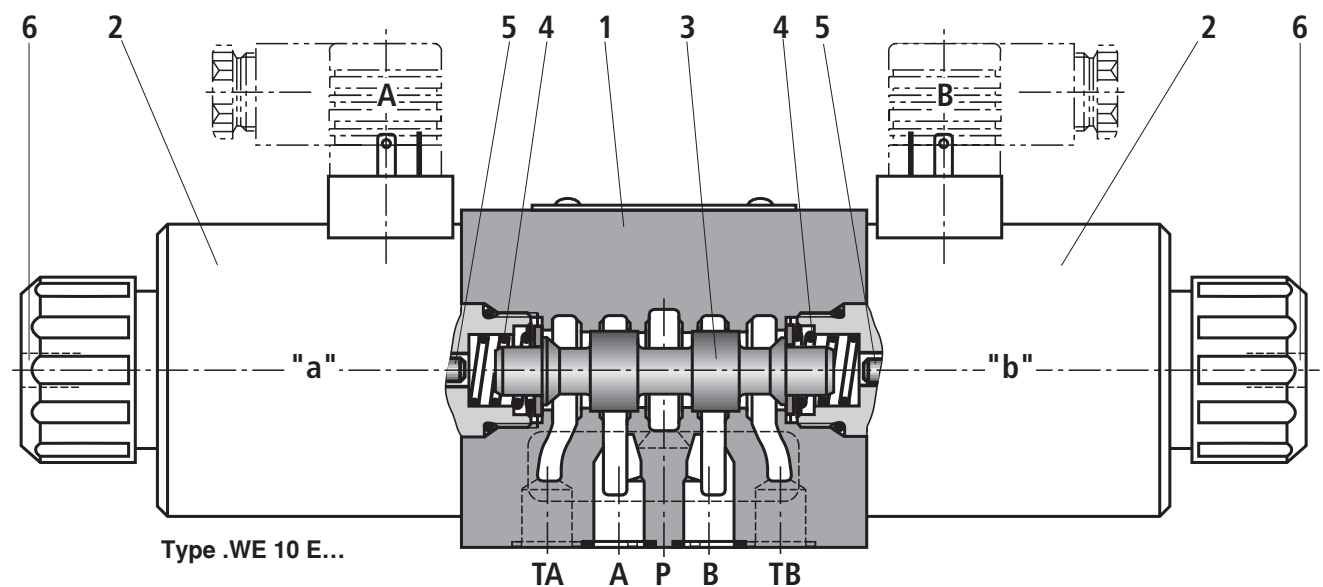

Throttle insert

The use of a throttle insert is required, if, due to the given operating conditions, flows can occur during the switching processes, which exceed the performance limit of the valve.

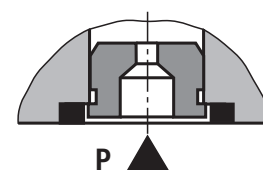

Technical data (for applications outside these parameters, please consult us!)

General				
Weight			Individual connection	Central connection
	– Valve with one solenoid	kg [lbs]	4.4 [9.7] (DC); 3.6 [7.9] (AC)	4.3 [9.5] (DC); 3.5 [7.7] (AC)
	– Valve with two solenoids	kg [lbs]	6.0 [13.2] (DC); 4.4 [9.7] (AC)	5.9 [13.0] (DC); 4.3 [9.5] (AC)
Installation position			Optional	
Ambient temperature range		°C [°F]	–30 to +50 [–22 to +122] (NBR seals) –20 to +50 [–4 to +122] (FKM seals)	
Hydraulic				
Maximum operating pressure	– Ports A, B, P	bar [psi]	315 [4569]	
	– Port T	bar [psi]	210 [3050] (DC); 160 [2320] (AC) With symbols A and B, port T must be used as leakage oil port, if the operating pressure is higher than the tank pressure.	
Maximum flow		l/min [US gpm]	120 [31.7]	
Flow cross-section (spool position 0)	– Spool symbol V	mm ² [inch ²]	11 [0.017] (A/B to T); 10,3 [0.016] (P to A/B)	
	– Spool symbol W	mm ² [inch ²]	2.5 [0.004] (A/B to T)	
	– Spool symbol Q	mm ² [inch ²]	5.5 [0.009] (A/B to T)	
Hydraulic fluid ¹⁾			Mineral oil (HL, HLP) to DIN 51524 ²⁾ ; fast bio-degradable hydraulic fluids to VDMA 24568 (see also RE 90221); HETG (rape seed oil) ²⁾ ; HEPG (polyglycols) ³⁾ ; HEES (synthetic esters) ³⁾ ; other hydraulic fluids on request	
Hydraulic fluid temperature range		°C [°F]	–30 to +80 [–22 to +176] (NBR seals) –20 to +80 [–4 to +176] (FKM seals)	
Viscosity range		mm ² /s [SUS]	2.8 to 500 [35 to 2320]	
Permissible max. degree of contamination of the hydraulic fluid - cleanliness class to ISO 4406 (c)			Class 20/18/15 ⁴⁾	

¹⁾ The ignition temperature of the process and operating medium used must be higher than the maximum solenoid surface temperature.

²⁾ Suitable for NBR and FKM seals

³⁾ Suitable only for FKM seals

⁴⁾ The cleanliness classes specified for components must be adhered to in hydraulic systems. Effective filtration prevents malfunction and, at the same time, prolongs the service life of components.

For the selection of filters, see data sheets RE 50070, RE 50076, RE 50081, RE 50086, RE 50087 and RE 50088.

Technical data (for applications outside these parameters, please consult us!)

Electrical

Type of voltage		DC voltage	AC voltage 50/60 Hz
Available voltages ⁵⁾ (Ordering code for AC solenoids, see below)	V	12, 24, 42, 60, 96, 110, 180, 205, 220	42, 110, 230
Voltage tolerance (nominal voltage)	%	±10	
Power consumption	W	35	–
Holding power	VA	–	90
Making capacity	VA	–	550
Duty cycle	%	100	
Switching time to ISO 6403	– ON	ms	45 to 60
	– OFF	ms	20 to 30
Maximum switching frequency	1/h	15000	7200
Maximum coil temperature ⁶⁾	°C [°F]	150 [302]	180 [356]
Type of protection to DIN EN 60529		IP 65 with mating connector mounted and locked	
Insulation class VDE 0580		F	H
Electrical protection		Each solenoid must be protected separately with a suitable fuse with tripping characteristic K (inductive loads).	
Behavior in the event of a fault (solenoid is not enabled)		The solenoid surface temperature can be exceeded.	

⁵⁾ Special voltages on request

⁶⁾ Due to the surface temperatures of the solenoid coils, observe standards ISO 13732-1 and EN 982!

Notes!

- The manual override can only be operated up to a tank pressure of ca. 50 bar. Avoid damage to the bore for the manual override! (Special tool for operation, separate order, Material no. **R900024943**). When the manual override is blocked, the operation of the opposite solenoid must be ruled out!
- The simultaneous operation of the solenoids must be ruled out!

Note!

AC solenoids can be used for 2 or 3 mains;
e.g. solenoid type **W110** for:
110 V, 50 Hz; 110 V, 60 Hz; 120 V, 60 Hz

Ordering code	Mains
W42	42 V, 50 Hz 42 V, 60 Hz
W110	110 V, 50 Hz 110 V, 60 Hz 120 V, 60 Hz
W230	230 V, 50 Hz 230 V, 60 Hz

When establishing the electrical connection, properly connect the protective earth conductor (PE \perp).

Characteristic curves (measured with HLP46, $\vartheta_{oil} = 40 \text{ }^\circ\text{C} \pm 5 \text{ }^\circ\text{C} [104 \text{ }^\circ\text{F} \pm 9 \text{ }^\circ\text{F}]$)

Δp - q_v characteristic curves

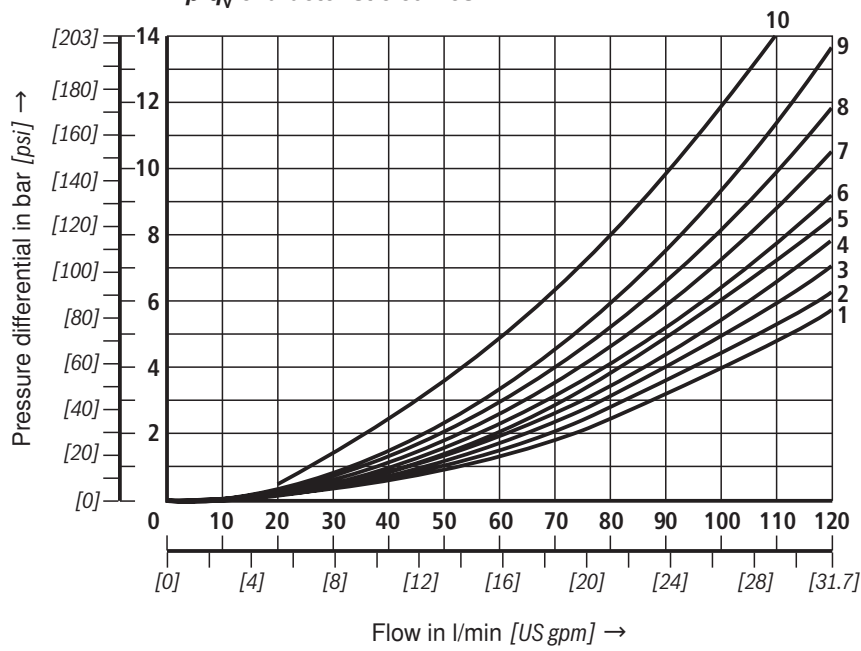

Spool symbol	Direction of flow			
	P - A	P - B	A - T	B - T
A; B	3	3	-	-
C	3	3	4	5
D; Y	5	5	6	6
E	1	1	4	4
F	2	3	7	4
G	3	3	6	7
H	1	1	6	7
J	1	1	3	3
L	2	2	3	5
M	1	1	4	5
P	4	2	5	7
Q	1	2	1	3
R	3	6	4	-
T	3	3	6	7
U; V	2	2	3	3
W	2	2	4	5

Central position:

Spool symbol	Direction of flow				
	P - A	P - B	B - T	A - T	P - T
F	4	-	-	9	9
P	-	5	8	-	10
G, T	-	-	-	-	9
H	-	-	-	-	3

Spool position:

Spool symbol	Direction of flow			
	P - A	B - A	A - T	P - T
R	-	9	-	-

Performance limits (measured with HLP46, $\vartheta_{oil} = 40 \text{ }^\circ\text{C} \pm 5 \text{ }^\circ\text{C}$ [104 °F ± 9 °F])

Attention!

The specified switching performance limits are valid for operation with two directions of flows (e.g. from P to A and simultaneous return flow from B to T).

Due to the flow forces acting within the valves, the permissible switching performance limit may be considerably lower

with only one direction of flow (e.g. from P to A while port B is blocked)!

In the case of such applications, please consult us!

The switching performance limit was established while the solenoids had reached operating temperature, at 10% undervoltage and without tank preloading.

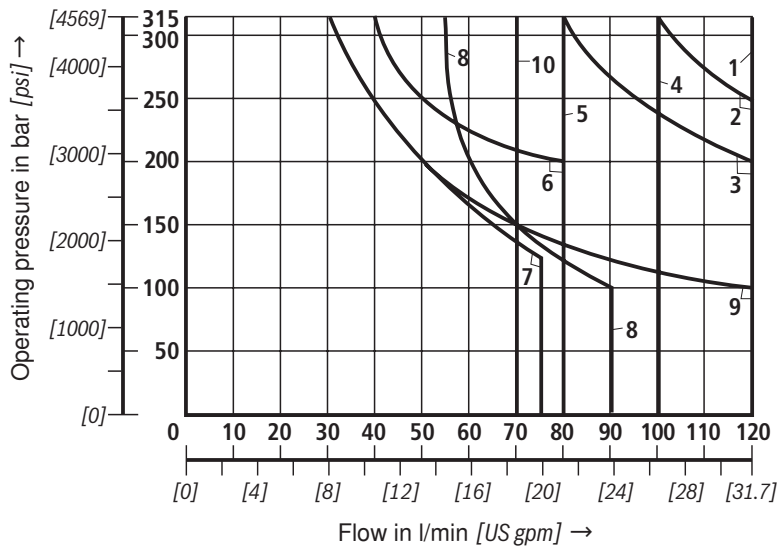

DC voltage	
Curve	Spool symbol
1	C; C/O; C/OF; D; D/O; D/OF; Y; M
2	E
3	A/O; A/OF; L; U; J; Q; W
4	H
5 ¹⁾	R; L ²⁾ ; U ²⁾
6	G
7	T
8	F; P
9	A; B
10	V

¹⁾ Return flow from actuator to tank (irrespective of the area ratio)

²⁾ Central position only

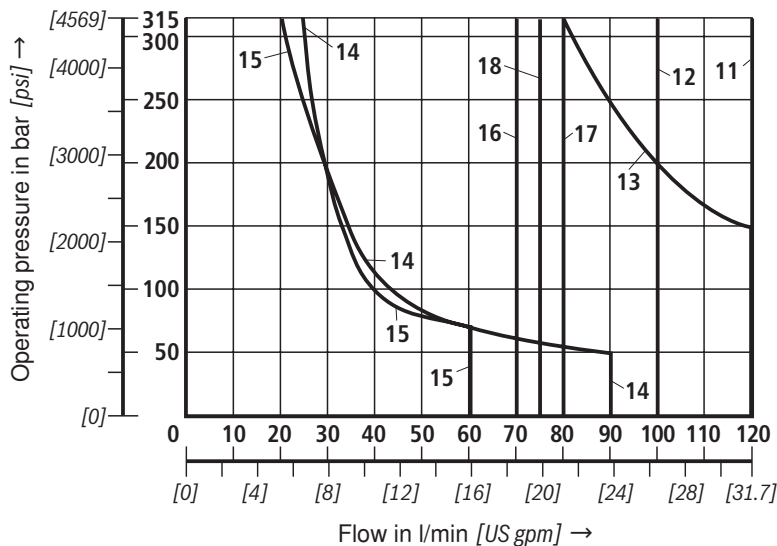

AC voltage	
Curve	Spool symbol
11	C; C/O; C/OF; D; D/O; D/OF; Y
12	E; L; U; Q; W
13	A/O; A/OF; J
14	F; P
15	T
16	H
17	R
18 ²⁾	L; U
19	M

²⁾ Central position only

42 V, 50 Hz; 110 V, 50 Hz; 120 V, 60 Hz; 127 V, 50 Hz; 220 V, 50 Hz; 240 V, 60 Hz

Performance limits (measured with HLP46, $\vartheta_{oil} = 40\text{ }^{\circ}\text{C} \pm 5\text{ }^{\circ}\text{C}$ [104 °F ± 9 °F])

Attention!

The specified switching performance limits are valid for operation with two directions of flows (e.g. from P to A and simultaneous return flow from B to T).

Due to the flow forces acting within the valves, the permissible switching performance limit may be considerably lower

with only one direction of flow (e.g. from P to A while port B is blocked)!

In the case of such applications, please consult us!

The switching performance limit was established while the solenoids had reached operating temperature, at 10% undervoltage and without tank preloading.

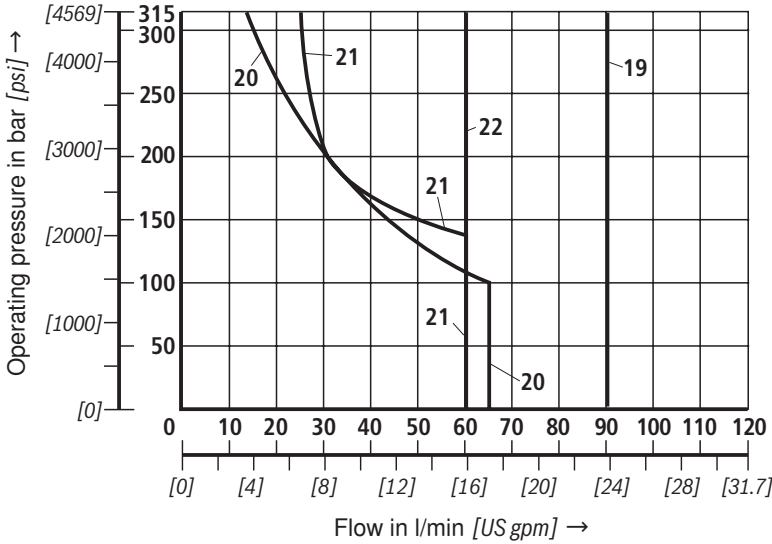

AC voltage	
Curve	Spool symbol
19	M
20	A, B
21	G
22	V

42 V, 50 Hz; 110 V, 50 Hz; 120 V, 60 Hz;
127 V, 50 Hz; 220 V, 50 Hz; 240 V, 60 Hz

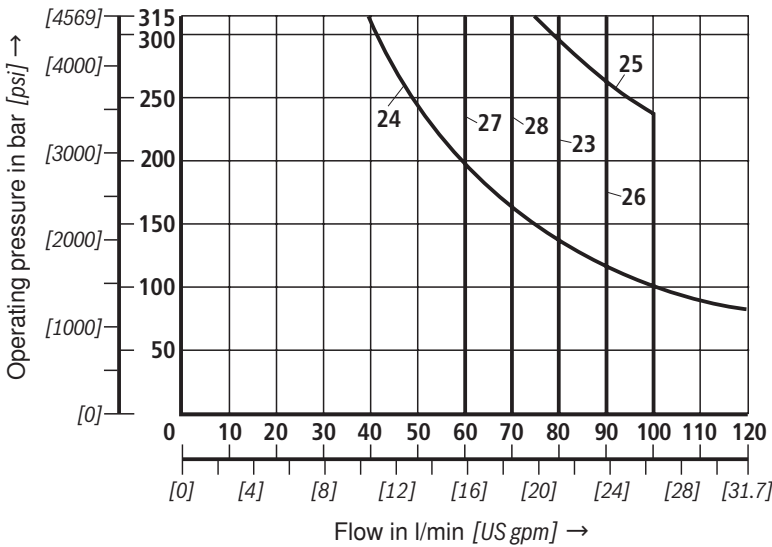

AC voltage	
Curve	Spool symbol
23	C; C/O; C/OF; D; D/O; D/OF; Y
24	A/O; A/OF
25	E
26	M
27	V
28	H

42 V, 60 Hz; 110 V, 60 Hz;
127 V, 60 Hz; 220 V, 60 Hz

For performance limits of other spools, please consult us!

Unit dimensions: Valve with DC solenoid (dimensions in mm [inch])

Individual connection

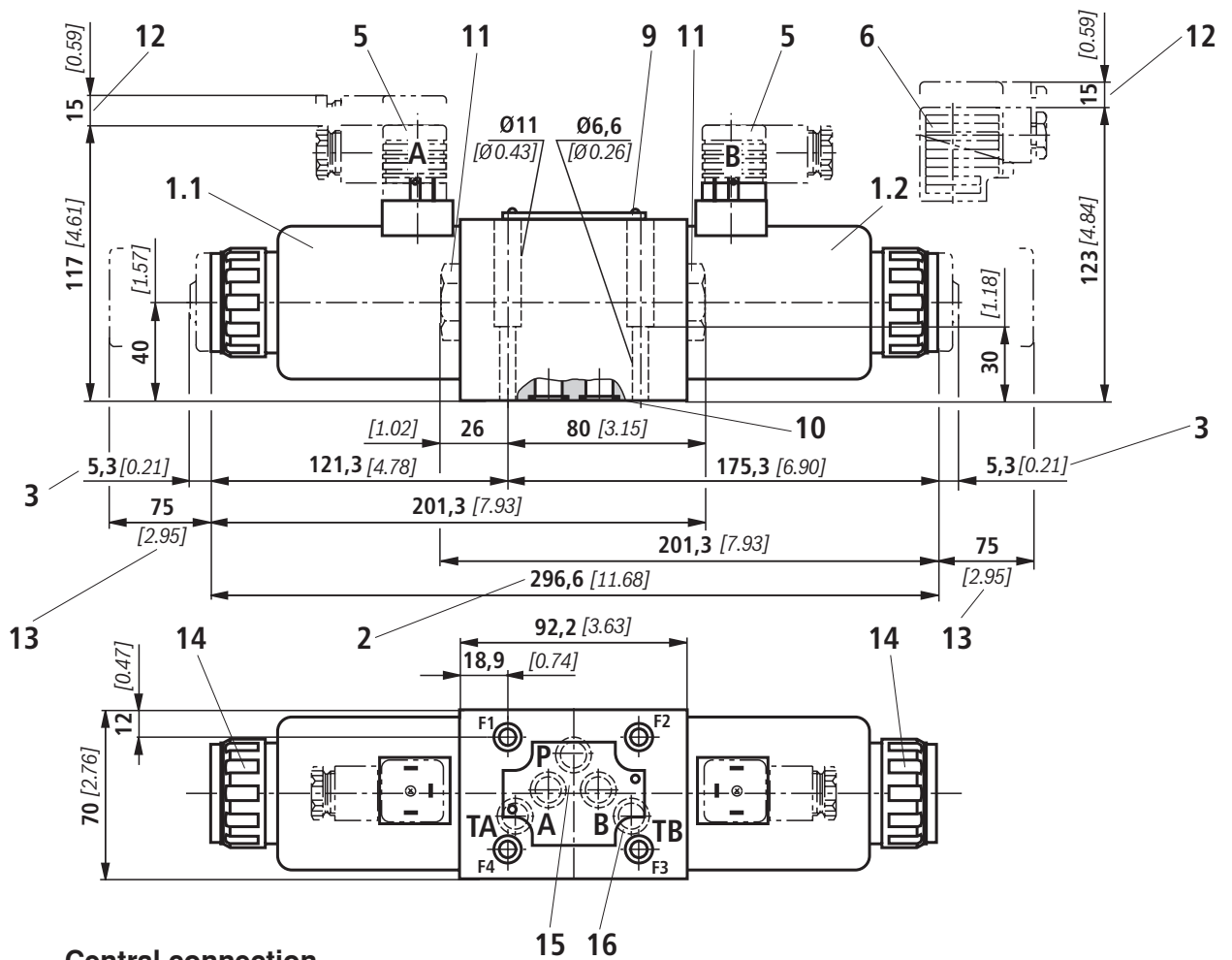

Central connection

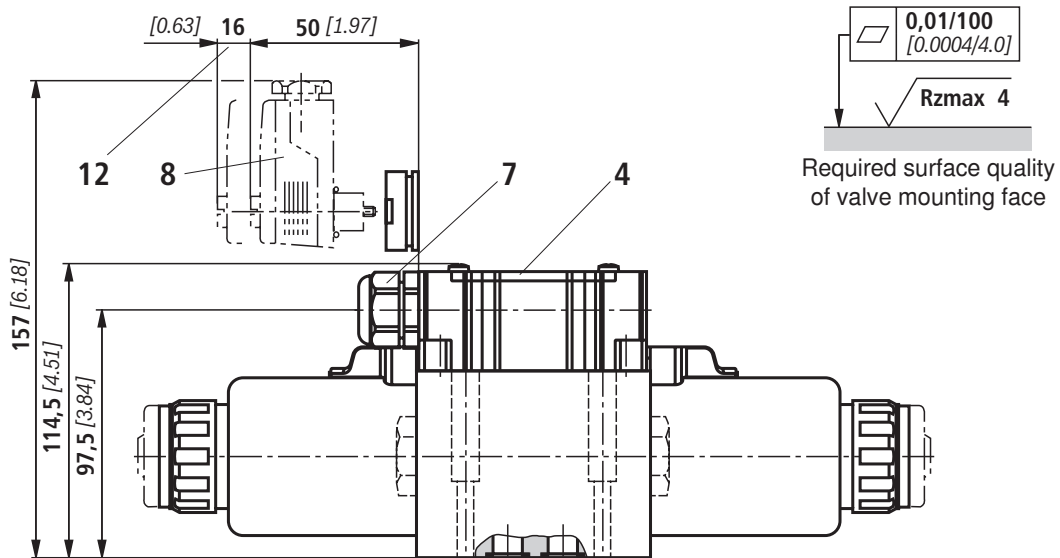

For explanations of items, valve mounting screws and subplates, see page 13.

Unit dimensions

- 1.1 Solenoid "a"
- 1.2 Solenoid "b"
 - 2 Dimension for solenoid **without** and **with concealed** manual override "N9" (standard)
 - 3 Dimension for solenoid **with** Manual override "N"
 - 4 Cover

Attention!
The valve may only be operated with properly mounted cover!
 - 5 Mating connector **without** circuitry (separate order, see page 3 and RE 08006)
 - 6 Mating connector **with** circuitry (separate order, see page 3 and RE 08006)
 - 7 Cable gland Pg 16 [1/2" NPT] "DL"
 - 8 Angled mating connector (color: red, separate order) Material no. **R900005538**
 - 9 Nameplate
 - 10 Identical seal rings for ports A, B, P, TA, TB (for valve with throttle insert, O-ring in channel P)
 - 11 Plug screw for valves with one solenoid
 - 12 Space required to remove mating connector/angled mating connector
 - 13 Space required to remove coil
 - 14 Locknut, tightening torque $M_T = 6^{+2}$ Nm [4.43^{+1.48} ft-lbs]
 - 15 Position of ports to ISO 4401-05-04-0-05 and NFPA T3.5.1 R2-2002 D05
 - 16 Port TB can only be used in conjunction with a bore to be provided separately.

Terminal assignment for central connection:

- **1 solenoid:**
Solenoid always to terminals 1 and 2, protective earth conductor to terminal \oplus PE
- **2 solenoids:**
Solenoid "a" to terminals 1 and 2, solenoid "b" to terminals 3 and 4, protective earth conductor to terminal \oplus PE

Subplates to data sheet RE 45054 (separate order)

G 66/01 (G3/8)

G 67/01 (G1/2)

G 534/01 (G3/4)

G 66/12 (SAE-6; 9/16-18)¹⁾

G 67/12 (SAE-8; 3/4-16)¹⁾

G 534/12 (SAE-12; 1-1/16-12)¹⁾

¹⁾ on request

Valve mounting screws (separate order)

4 hexagon socket head cap screws, metric

ISO 4762 - M6 x 40 - 10.9-flZn-240h-L

(Friction coefficient $\mu_{\text{total}} = 0.09$ to 0.14);

tightening torque $M_T = 12.5$ Nm [9.2 ft-lbs] $\pm 10\%$,

Material no. **R913000058**

or

4 hexagon socket head cap screws

ISO 4762 - M6 x 40 - 10.9 (to be provided by customer)

(Friction coefficient $\mu_{\text{total}} = 0.12$ to 0.17);

tightening torque $M_T = 15.5$ Nm [11.4 ft-lbs] $\pm 10\%$

4 hexagon socket head cap screws, UNC

1/4-20 UNC x 1-1/2" ASTM-A574

(Friction coefficient $\mu_{\text{total}} = 0.19$ to 0.24);

tightening torque $M_T = 20$ Nm [14.7 ft-lbs] $\pm 15\%$,

(Friction coefficient $\mu_{\text{total}} = 0.12$ to 0.17);

tightening torque $M_T = 14$ Nm [10.3 ft-lbs] $\pm 10\%$,

Material no. **R978800710**

Notes

Bosch Rexroth AG
Hydraulics
Zum Eisengießer 1
97816 Lohr am Main, Germany
Phone +49 (0) 93 52 / 18-0
Fax +49 (0) 93 52 / 18-23 58
documentation@boschrexroth.de
www.boschrexroth.de

© This document, as well as the data, specifications and other information set forth in it, are the exclusive property of Bosch Rexroth AG. It may not be reproduced or given to third parties without its consent. The data specified above only serve to describe the product. No statements concerning a certain condition or suitability for a certain application can be derived from our information. The information given does not release the user from the obligation of own judgment and verification. It must be remembered that our products are subject to a natural process of wear and aging.

Notes

Bosch Rexroth AG
Hydraulics
Zum Eisengießer 1
97816 Lohr am Main, Germany
Phone +49 (0) 93 52 / 18-0
Fax +49 (0) 93 52 / 18-23 58
documentation@boschrexroth.de
www.boschrexroth.de

© This document, as well as the data, specifications and other information set forth in it, are the exclusive property of Bosch Rexroth AG. It may not be reproduced or given to third parties without its consent. The data specified above only serve to describe the product. No statements concerning a certain condition or suitability for a certain application can be derived from our information. The information given does not release the user from the obligation of own judgment and verification. It must be remembered that our products are subject to a natural process of wear and aging.

Notes

Bosch Rexroth AG
Hydraulics
Zum Eisengießer 1
97816 Lohr am Main, Germany
Phone +49 (0) 93 52 / 18-0
Fax +49 (0) 93 52 / 18-23 58
documentation@boschrexroth.de
www.boschrexroth.de

© This document, as well as the data, specifications and other information set forth in it, are the exclusive property of Bosch Rexroth AG. It may not be reproduced or given to third parties without its consent. The data specified above only serve to describe the product. No statements concerning a certain condition or suitability for a certain application can be derived from our information. The information given does not release the user from the obligation of own judgment and verification. It must be remembered that our products are subject to a natural process of wear and aging.