

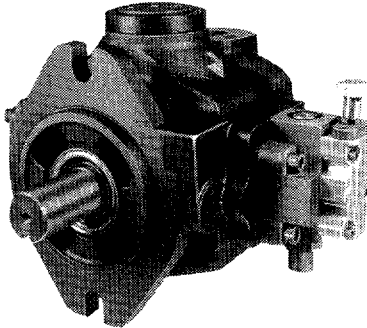

BOSCH



Engineering Data

VARIABLE VOLUME

VANE PUMPS

MODEL SV-80

MODEL SV-100

FLANGE MOUNTED

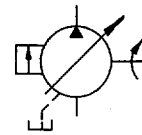

SYMBOL

QUICK REFERENCE CHART

MODEL	GPM @ 100 PSI & 1800 RPM	MAXIMUM PRESSURE (PSI)	MAXIMUM RPM	PRESSURE COMPENSATING RANGE (PSI)	THEORETICAL DISPLACEMENT IN ³ /REV	INPUT HP @ MAX PSI & 1800 RPM
SV-80	62	1500	1800	300-1500	8	62
SV-100	78	1000	1800	250-1000	10	51

STANDARD PUMP — The SV pump is a pressure compensated vane pump and is available in four basic displacements; one, two, four, and eight cubic inches. This bulletin covers the model SV-80 (eight cubic inch displacement) and variations of it all of which are dimensionally the same. The SV-100 is a modified SV-80 which uses a different ring to allow the ring to shift further and increase the displacement. By increasing the ring stroke, the vanes extend further and requires the maximum pressure rating to be reduced. Increasing the flow of the basic pump allows the design engineer to reduce circuit costs by using a smaller pump instead of selecting a larger size provided the reduced pressure rating is adequate.

PRODUCT LITERATURE DISCLAIMER

SPECIFICATIONS AND/OR DIMENSIONS ARE SUBJECT TO CHANGE WITHOUT PRIOR NOTICE. PLEASE CONSULT FACTORY.

SPECIFICATIONS

STANDARD PUMP

PRESSURE RATING —

SV-80 — 1500 psi (103 bar)
SV-100 — 1000 psi (69 bar)

PRESSURE COMPENSATING RANGE —

SV-80 — 300-1500 psi (28-103 bar)
SV-100 — 250-1000 psi (17-69 bar)

FLOW AT 1800 rpm —

SV-80 — 60 gpm (227 l/min) at 1400 psi
SV-100 — 75 gpm (284 l/min) at 900 psi

THEORETICAL DISPLACEMENT —

SV-80 — 8 in³/rev (131.2 ml/rev)
SV-100 — 10 in³/rev (164 ml/rev)

MAXIMUM INLET VACUUM AT SEA LEVEL —

SV-80 — 6 in. Hg (152 mm Hg)
SV-100 — 4 in. Hg (102 mm Hg)

MAXIMUM CASE PRESSURE — 10 psi (0.7 bar)

Case drain line should be full intended size (not reduced down). Case pressure spikes can be minimized by using as straight and direct a path to tank as possible. Other drain lines should not be connected to the pump drain line. Always terminate the drain line below the fluid level in the reservoir. Failure to do so will result in loss of pump prime approximately 30 minutes after it is shut down and possible introduction of air into the circuit. Case drain line should be routed to the opposite side of baffle in relation to suction line.

CASE DRAIN FLOW — The values listed below are the average flows which occur only when the pump is compensating. When the pump is not compensating, the values are much lower.

500 in³/min (8.2 l/min) at 1000 psi (69 bar)
600 in³/min (9.8 l/min) at 1500 psi (103 bar)

DRIVE SPEED RANGE — 750-1800 rpm

(Consult factory Applications Dept. for higher speeds)

MOUNTING — SAE D 2-Bolt Flange, side or rear ported.

ROTATION — Right hand rotation. Rotation is always determined when viewing the shaft end.

SEALS — Viton is compatible with all of the fluids mentioned.

FILTRATION — A 10 micrometre return line filter is recommended for increased pump life. Suction strainer is not recommended, but if used, it should not be finer than 100 mesh (149 micrometre) when using petroleum fluids. The higher specific gravity of fire resistant fluids and the higher vapor pressure of the water containing fluids will aggravate the pump inlet conditions. If a suction strainer is used with these fluids, the mesh must be coarser (60 mesh or 238 micrometre) than what is used with petroleum oil or the surface area increased to reduce the pressure drop.

OVERHUNG LOAD — Radial and axial forces on the shaft are not recommended. Pump and prime mover should be mounted with shafts inline (coaxial) and connected with a flexible coupling. Consult factory Applications Dept. for applications with overhung load.

FLUID RECOMMENDATIONS — A premium quality hydraulic oil with zinc complex anti-wear additives is highly recommended. Refer to BOSCH publication HPUS WRY S/106 US, "Petroleum Hydraulic Fluids" for a list of fluids which meet or exceed the BOSCH lubrication requirements.

Optimum Viscosity at Operating Temperature	200-300 SUS (43-65 cSt)
Minimum Operating Viscosity	150 SUS (32 cSt)
Maximum Operating Viscosity	1000 SUS (215 cSt)
Maximum Start-up Viscosity	4000 SUS (864 cSt)

To compensate for the reduced lubrication values of even the premium quality water containing fluids (glycols and water-in-oil emulsions), it is necessary to limit system pressure and rpm to the values listed in the table below for an equivalent life.

	Water Glycol	Water-in-Oil Emulsion
Maximum Pressure	1000 psi	750 psi
Maximum RPM	1800 rpm	1200 rpm

Refer to BOSCH publication HPUS WRY S/107 US, "Fire Resistant Fluids" for further details on fluid selection. Fluid suppliers should be consulted regarding proper fluid maintenance when using fire resistant fluids containing water.

TEMPERATURE — The temperature of the fluid in the reservoir should not exceed 130°F (54°C). The pump will operate with oil at higher temperatures provided the viscosity of the fluid is within the recommended range. Under no circumstances should the oil temperature exceed 160°F (71°C). When using fire resistant fluids containing water, the fluid temperature should not exceed 120°F (49°C) to prevent an excessive rate of water evaporation.

SCREW VOLUME CONTROL — The screw volume control is an adjustable stop which is used to reduce the maximum pump flow and is optional. Turning clockwise will reduce the flow in direct proportion to the displacement of the adjusting screw. During initial start-up, the flow setting should be at least 30% of the maximum pump flow.

SV-80 — 1/4 turn (90°) clockwise will reduce the flow approximately 5.6 gpm (21.2 l/min) when the pump is driven at 1800 rpm.

SV-100 — 1/4 turn (90°) clockwise will reduce the flow approximately 7 gpm (26.5 l/min) when the pump is driven at 1800 rpm.

When a volume control is used to reduce the maximum flow of the pump, the horsepower required to drive the pump is also reduced. To determine the Input HP, use the following formula:

$$\text{Input HP} = \frac{\text{gpm} \times \text{psi}}{1714} + \text{Deadhead HP at the compensator setting}$$

MOUNTING POSITION — Pump should be mounted with the shaft horizontal. Caution must be exercised to prevent end thrust from being applied to the shaft.

SHAFT ALIGNMENT — Shaft alignment should be within 0.003" total indicator reading. If the shafts are not properly aligned, increased mechanical noise from the unit will result.

START-UP — To insure priming on initial start-up, air in the pump and inlet line must be allowed to escape. If the pump outlet is normally blocked, it must be temporarily vented. This can be accomplished by opening the valve, temporarily cracking a fitting, or installing an air bleed valve.

CONTROL OPTIONS — Many energy saving controls are available in addition to the standard two-stage pressure compensator.

COMBINATION MOUNTING — To simplify multi-pump circuits, adaptor kits are available to mount additional pumps in combination on the rear cover of the flange mounted (side ported) pumps.

WEIGHT (Approximate) —
 Flange Mounted Pump175 lbs. (78 Kg)
 Add for Screw Volume Control1 lbs. (0.5 Kg)

PERFORMANCE CHARACTERISTICS

STANDARD PUMP

DATA PLOTTED WITH OIL AT 120°F (49°C)
 VISCOSITY @ 120°F = 140 SUS (29.6 cSt)

SV-80 @ 1200 rpm

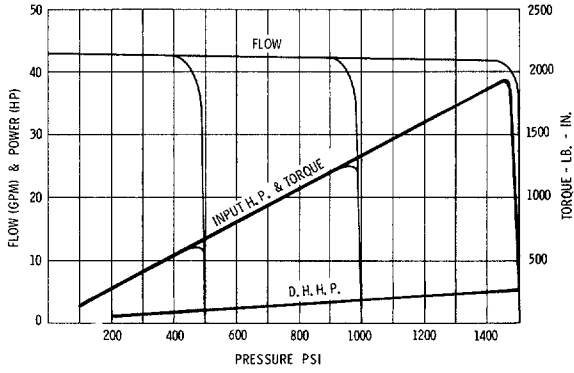

SV-80 @ 1800 rpm

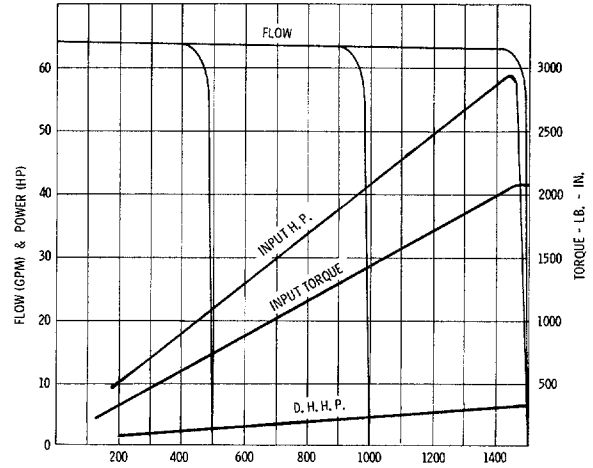

SV-100 @ 1200 rpm

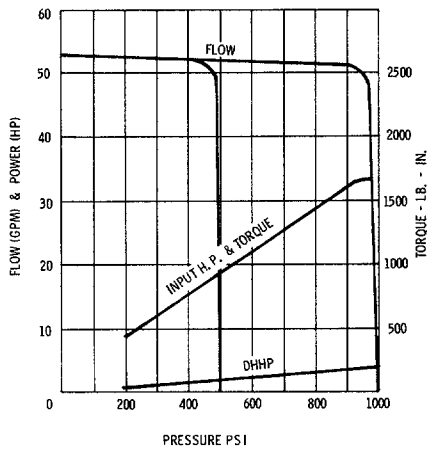

SV-100 @ 1800 rpm

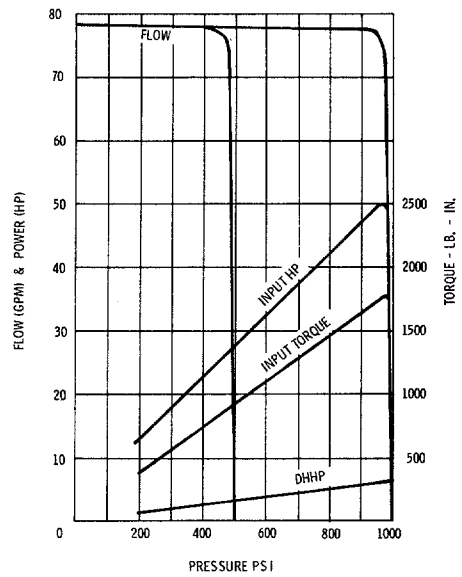

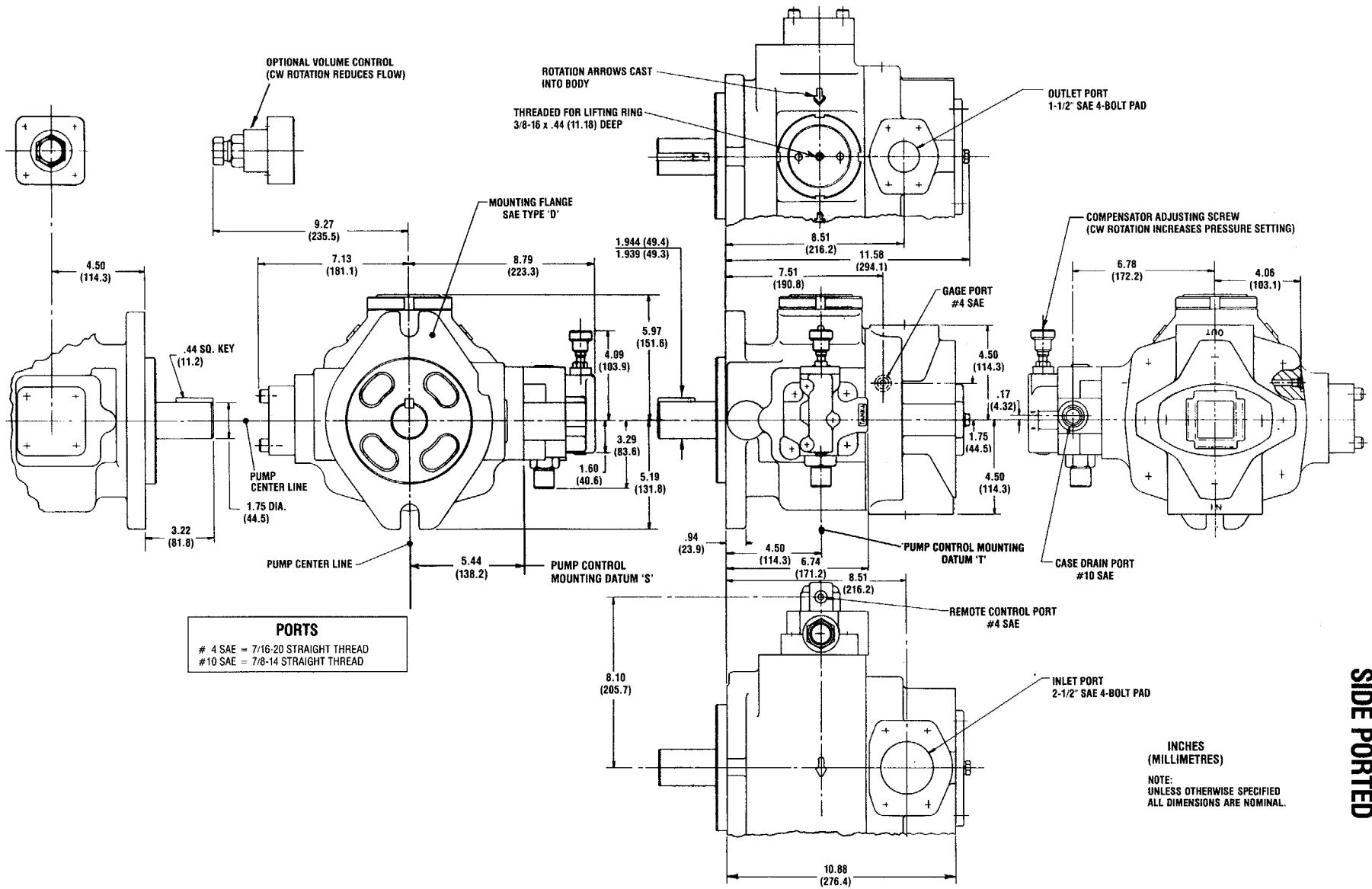

RIGHT HAND ROTATION
SIDE PORTED

DIMENSIONAL DATA

FOOT BRACKET (PSV-80-10B)

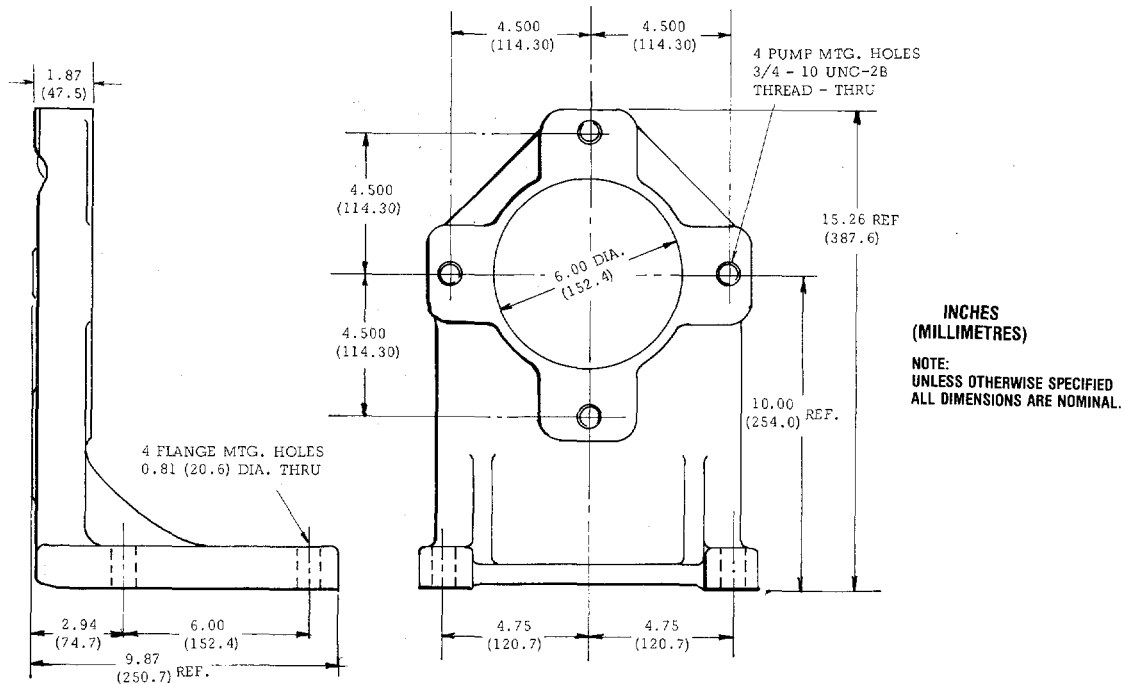

Bolt kit B-111 is included to mount the pump to the foot bracket. Consists of 2 each 3/4-10 x 3 hex head cap screw and washer.

The center line height of the shaft of an electric motor can be determined by dividing the first two numbers of the motor frame by four.

HOW TO ORDER

FOOT BRACKET

*BRACKET MODEL NUMBER	HEIGHT OF PUMP SHAFT CENTER LINE WHEN MOUNTED TO BRACKET
PSV-80-10B	10.00 (254 MM)

*Includes bolt kit B-111 to mount pump to bracket.

Foot bracket and mounting bolts are not included with the pump and must be specified in addition to the pump.

Example: (1) PSV-PNCO-80GRM-62 Pump
(1) PSV-80-10B Foot Bracket

FLANGE KIT

FLANGE KIT NO.	CONSISTING OF
PSV-80-20F	1 EA - 2-1/2" NPT FLANGE (INLET) 4 EA - 1/2-13 x 2-1/4 SOCKET HEAD CAP SCREW 1 EA - 1/8 x 2-3/4 x 3 O-RING 1 EA - 1-1/2 NPT FLANGE (OUTLET) 4 EA - 1/2-13 x 2 SOCKET HEAD CAP SCREW 1 EA - 1/8 x 1-7/8 x 2-1/8 O-RING

Flanges are not included with the pump and must be specified in addition to the pump.

Example: (1) PSV-PNCO-80GRM-62
(1) PSV-80-20F Flange Kit

STANDARD PUMP

PSV-PNCF-80GRM-62

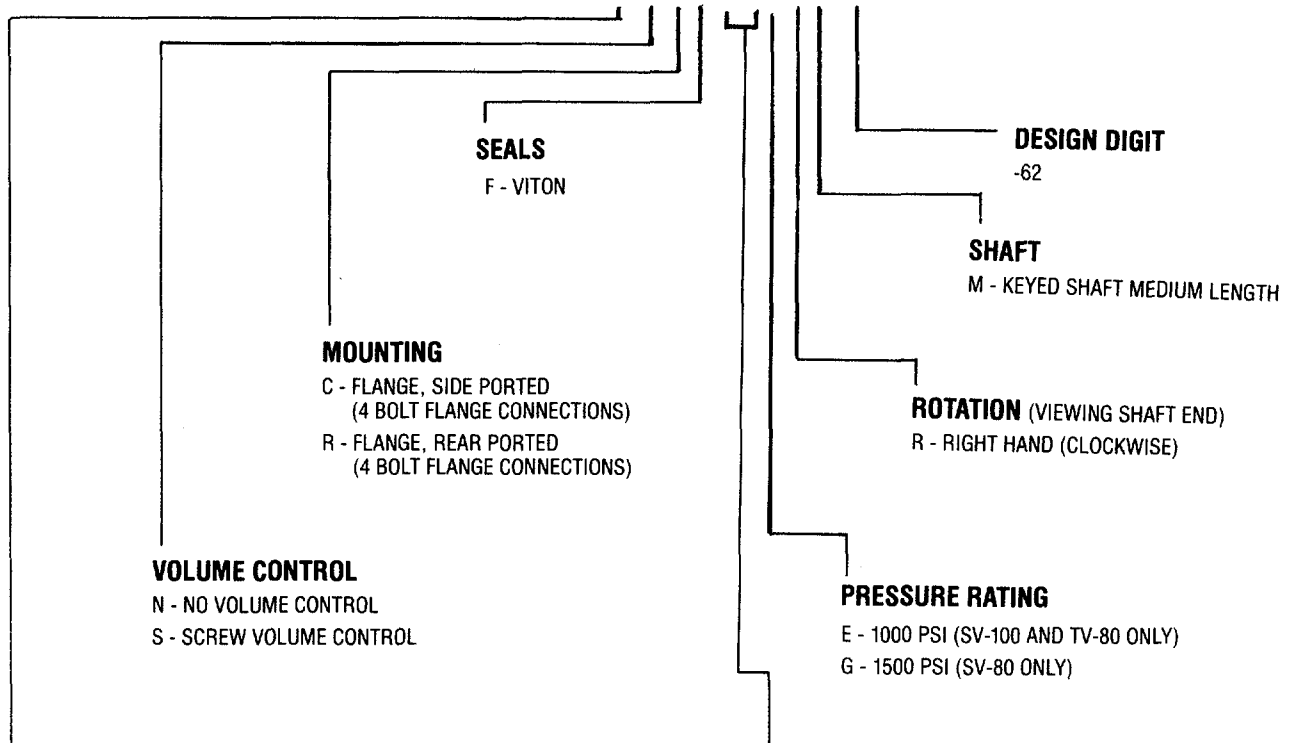

CONTROL OPTIONS

- P - STANDARD PRESSURE COMPENSATOR
- *S - SOLENOID TWO-PRESSURE (NORMALLY LOW, ENERGIZE FOR HIGH PRESSURE)
- *H - SOLENOID TWO-PRESSURE (NORMALLY HIGH, ENERGIZE FOR LOW PRESSURE)
- *V - SOLENOID TWO-PRESSURE (NORMALLY VENTED, ENERGIZE FOR HIGH PRESSURE)
- J - HYDRAULIC TWO-PRESSURE (NORMALLY LOW, ENERGIZE FOR HIGH PRESSURE)
- L - LOAD SENSING
- T - TORQUE LIMITING
- K - SINGLE STAGE PRESSURE COMPENSATOR

*Indicate the desired solenoid voltage and frequency at the end of the pump code.

FLOW @ 1800 RPM

- 80 - 60 GPM @ 1400 PSI
- 100 - 75 GPM @ 900 PSI

SOLENOID VOLTAGES AVAILABLE
110/115 VAC 50/60 HZ (DUAL FREQUENCY)
220/230 VAC 50/60 HZ (DUAL FREQUENCY)
12 VDC
24 VDC
FOR SOLENOIDS WITH QUICK CONNECT (HIRSCHMANN TYPE) CONSULT FACTORY

NOTE: To order the lock for the compensator adjusting screw, specify "LOCK" at the end of the code.

9 535 233 091
HPUS AKY 003/4 US (1.96)

ROBERT BOSCH FLUID POWER CORPORATION
P.O. BOX 2025
RACINE, WISCONSIN 53401-2025 U.S.A.
Phone (414)554-7100, Fax (414)554-7117



BOSCH

PRINTED IN U.S.A.