

VPV Controls



Industrial Hydraulics

Table of Contents

Proper Setting of the Thrust Screw 2

Adjustment Procedures – Single Stage Compensator 4

Adjustment Procedures – Two-Stage Compensator 7

Solenoid Two-Pressure Control 9

Solenoid Vented 11

Load Sense (Flow Control) 12

Torque Limiter 15

VPV Compensator Part Numbers 20

Proper Setting of the Thrust Screw

1. Make sure the pump is in “deadhead” condition before attempting adjustment of the thrust screw. The “deadhead”, or compensated condition, can be reached by blocking the outlet port by shutting off downstream valves which means that the output flow is blocked. The output flow must be completely shut off. Any valve leakage will affect the proper setting of the pump.
2. Loosen the pressure adjustment locknut on the compensator.
3. Back off the pressure adjustment to its absolute minimum (until it stops) by turning counterclockwise. On a two-stage control, this adjustment is on the second stage (the top assembly).
4. If your pump has a torque limiter control, back out the torque limiter adjustment all the way.
5. Using a flat blade screwdriver back out the first stage adjustment to its absolute minimum (until it stops).
6. Determine the size and pressure rating of the pump by observing the I.D. tag on the pump cover. If you have a combination pump the I.D. tag is on the adaptor of pump #1. The hydraulic code will state the size in cc/rev in the following manner: 0513R18C3VPV63SM21HYBO1. The pressure in this example is 210 bar or 3000 PSI: 0513R18C3VPV63SM**21**HYBO1, **21**= 210 bar/3000 PSI, **14** = 140 bar /2000 PSI. Additional code information can be found in the catalog, document #9 535 233 724, or the Pump I.D. Guides, SAE #9 535 233 782, Metric #9 535 233 785. See the minimum thrust screw settings and differential pressures as shown below.

Table 1: 1800 rpm Two-Stage Compensator

Size	Thrust Screw	Differential Setting (1st stage)
VPV 16 2000 PSI	170-190 PSI	100-110 PSI
VPV 16 3000 PSI	170-190 PSI	100-110 PSI
VPV 25/32 2000 PSI	160-180 PSI	100-110 PSI
VPV 25/32 3000 PSI	190-205 PSI	100-110 PSI
VPV 45/63/80 2000 PSI	190-210 PSI	100-110 PSI
VPV 45/63/80 3000 PSI	230-250 PSI	100-110 PSI
VPV 100/130/164 2000 PSI	180-200 PSI	100-110 PSI
VPV 100/130/164 3000 PSI	210-230 PSI	100-110 PSI

Note:

On the VPV 16–32 the shock clipper port must be blocked when calibrating the pump. The first stage setting is always additive to the thrust screw setting.

Thrust Screw Setting + Differential Spring (first stage) = Total Minimum Setting

Example for the VPV 164 (1800 rpm, 3000 PSI):

1 st adjustment – Thrust screw adjustment	210-230 PSI
2 nd adjustment – Differential Spring (first stage)	100-110 PSI
Total adjustment setting	310-340 PSI

Proper Setting of the Thrust Screw

Table 2: 1500 rpm Two-Stage Compensator

Size	Thrust Screw	Differential Setting (1st stage)
VPV 16 2000 PSI (140 bar)	165-185 PSI	100-110 PSI
VPV 16 3000 PSI (210 bar)	165-185 PSI	100-110 PSI
VPV 25/32 2000 PSI	155-175 PSI	100-110 PSI
VPV 25/32 3000 PSI	170-185 PSI	100-110 PSI
VPV 45/63/80 2000 PSI	185-205 PSI	100-110 PSI
VPV 45/63/80 3000 PSI	210-225 PSI	100-110 PSI
VPV 100/130/164 2000 PSI	145-165 PSI	100-110 PSI
VPV 100/130/164 3000 PSI	190-210 PSI	100-110 PSI

Example for the VPV 164 (1500 rpm, 3000 PSI):

1 st adjustment – Thrust screw adjustment	190-210 PSI
2 nd adjustment – Differential Spring (first stage)	100-110 PSI
Total adjustment setting	290-320 PSI

7. If you are working with a VPV 16, 25 or 32 make sure the shock clipper port is blocked (located on the first stage, the lower section of the two-stage control) before adjusting the thrust screw. For VPV 45–164 there is no external shock clipper port, therefore proceed to the next step.
8. If the pump has a stroke limiter, also known as a max. flow limiter or volume control, make sure it is backed out all the way. This is done by turning the bolt at the position on the pump housing opposite the pump control.
9. To adjust the thrust screw loosen the thrust screw locking nut. For VPV 16–32 a 5/16" Allen wrench is required. For the VPV 45–164 a spanner wrench is required. The spanner is available in the VPV Tool Kit, Bosch part number 9 511 230 557.
 - While observing a pressure gage turn the thrust screw clockwise to increase pressure, or counter-clockwise to decrease pressure, to the appropriate thrust screw pressure in the proper table above. Be careful, the thrust screw should not be turned more than 1/4 turn in either direction.
 - Once the proper minimum thrust screw pressure is reached by adjusting the thrust screw, then adjust the differential pressure on the first stage compensator with a flat blade screwdriver. Adjust the first stage differential screw 110 PSI over the thrust screw setting.
 - It is useful to “jog” the pump from deadhead to full flow several times and then re-check the thrust screw setting to assure repeatability.
10. Turn the second stage compensator knob in to the desired pressure and lock the setting with the jam nut.
11. Replace the lock nut on the thrust screw and tighten securely.

Adjustment Procedures – Single Stage Compensator

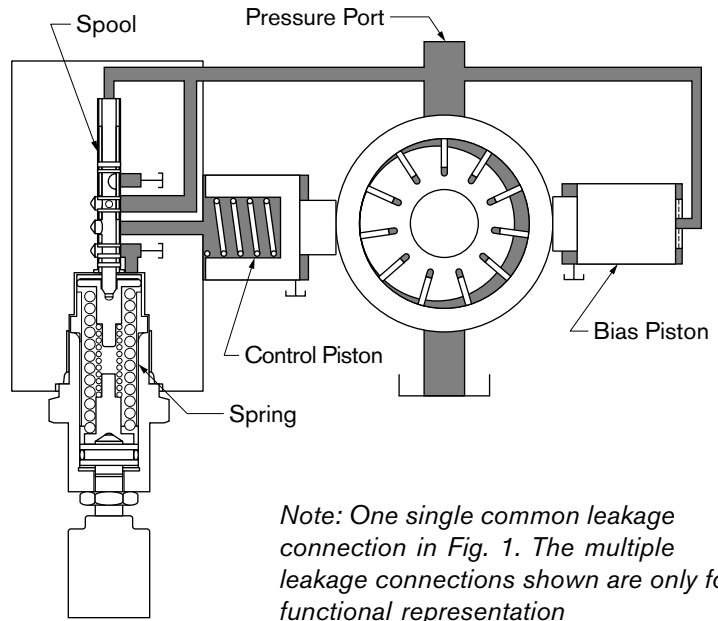
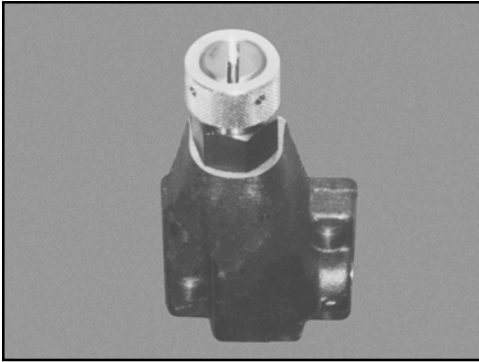

Fig. 1

Note: One single common leakage connection in Fig. 1. The multiple leakage connections shown are only for functional representation

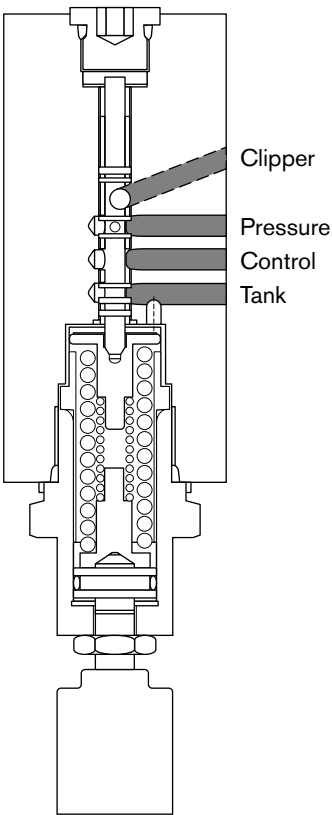

Fig. 2: Actual Representation of Fluid Paths.

The single stage compensator consists of a spool, spring and adjusting screw, which are assembled in a body and bolted to the pump body. To control the pressure at the control piston, the spool is designed to meter fluid in and out of the control piston chamber. A hole is drilled about three-fourths the length of the spool and intersects with a hole drilled at a right angle to the spool axis. The purpose of these holes is to allow fluid to flow from the pressure port of the pump to the end of the spool. No matter what position the spool is in, system pressure is applied to the end of the spool, creating a force, which opposes the spring force. As the system pressure increases, the force on the end of the spool also increases and the balance of forces determines the spool position. The spring cavity of the compensator is drained to tank to prevent any pressure buildup from leakage, which would add to the spring force and change the compensator setting.

The compensator spool (Fig. 2) is really an infinite positioning servo valve held offset by the compensator adjusting spring and activated by system pressure. To simplify the explanation, the spool travel will be broken down into two finite spool positions, which are shown in Table 3.

Table 3:

Spool Position	Pump Condition	System condition
1	Full Flow	System Pressure < Compensator Setting
2	Deadhead	System Pressure > Compensator Setting

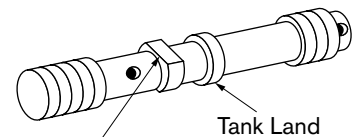

Two Flats are Placed on Orifice Land 180° Apart

Fig. 3: Compensator Spool

Adjustment Procedures – Single Stage Compensator

When there is no resistance to pump flow, the spring will force the spool into the spring offset or “bottomed out” position (Fig. 4) shown. In this position, fluid from the pressure port can flow through the compensator to the control piston and allow system pressure to be applied to the control piston. A land on the spool (tank land) prevents the fluid in the control piston chamber from flowing to tank. Because the control piston has twice the area of the bias piston and the same pressure is applied to both pistons, the greater force exerted by the control piston will force the ring into the on-stroke or flow position. The length of the bias piston, which bottoms out against the bias cover and prevents the ring from over-stroking and hitting the rotor, establishes the maximum flow rate.

As the resistance to pump flow increases, the pressure will be sensed on the end of the spool and when the force exerted is great enough to partially compress the spring, the spool will move. The ring will remain in the on-stroke or flow position because the tank line is still blocked and fluid can flow to the control piston through an orifice created by two flats ground on the adjacent land (orifice land).

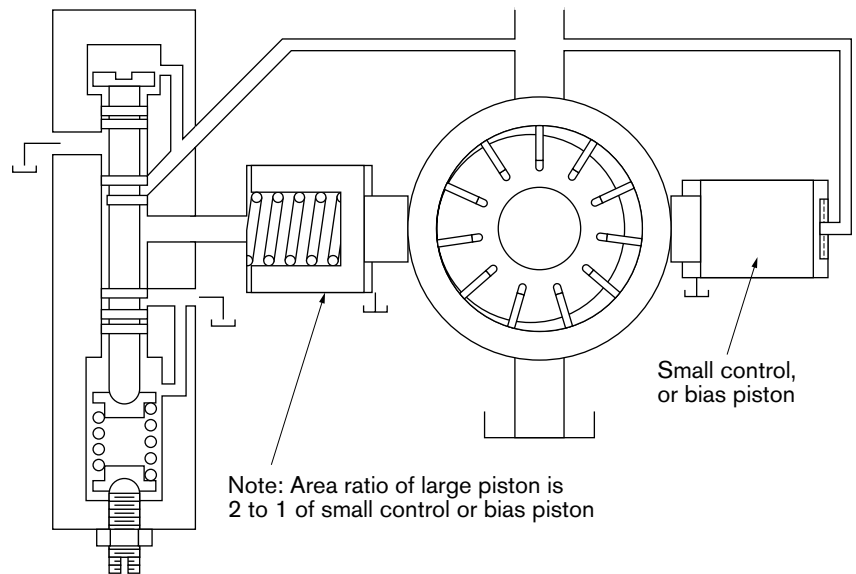

Fig. 4

As the resistance to pump flow increases, the pressure will be sensed on the end of the spool and when the force exerted is great enough to partially compress the spring, the spool will move. The ring will remain in the on-stroke or flow position because the tank line is still blocked and fluid can flow to the control piston through an orifice created by two flats ground on the adjacent land (orifice land).

Adjustment Procedures – Single Stage Compensator

When the system pressure reaches the compensator setting (spring precompression), the spool will move into position #2 (Fig. 5) which meters fluid out of the control piston chamber as well as into it.

The further the spool moves, the greater will be the amount of fluid bled off from the control piston chamber across the variable orifice created by the tank land. Since the flow of fluid to the control piston is limited by the orifice created by the flats on the pressure land, the pressure in the control chamber has dropped to approximately half of the outlet pressure, the bias piston force will exceed the control piston force and move the ring off-stroke, reducing flow. As the ring shifts, the flow rate out of the pump is being reduced and the compensator is positioning the ring to find the exact flow rate necessary to maintain the pressure setting on the compensator. If the pump flow becomes blocked, the ring will continue to be destroyed until the deadhead or no-flow position is reached. Remember that system pressure is always applied to the bias piston, which is trying to push the ring off-stroke. A balance of forces of the control piston versus bias piston determines the ring position.

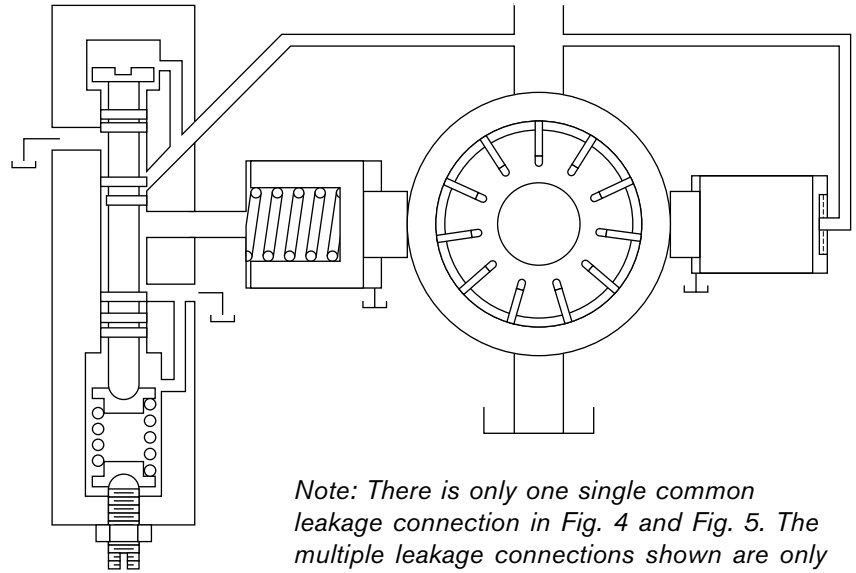

Note: There is only one single common leakage connection in Fig. 4 and Fig. 5. The multiple leakage connections shown are only for functional representation

Fig. 5: Position 2- Deadhead

To set-up a single stage compensator, follow the instructions given in Section 1 on how to set a thrust screw. Once the thrust screw pressure is set, adjust and lock the compensator knob at the maximum compensating pressure of your system.

If servicing of the single stage control is required, it is recommended to use the compensator seal kits identified in Table 4. Included in each compensator seal kit are all compensator O-rings, back-up rings a replacement poppet and poppet seat.

Table 4: Compensator Seal Kit for Single Stage Compensator 3000 PSI

VPV	SAE	METRIC
16/25/32	9 511 230 625	9 511 230 626

Adjustment Procedures – Two-Stage Compensator

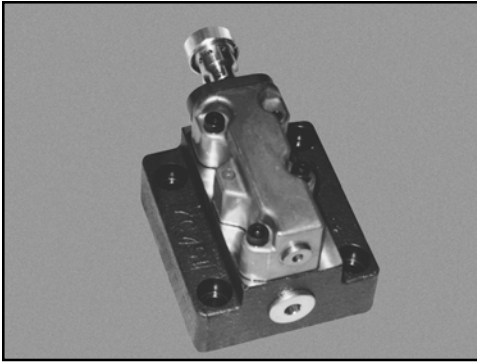

The two-stage control works exactly the same as the single stage control. However, instead of loading the spool with a spring, it is hydraulically loaded. To do this, a small relief valve referred to as the second stage is connected to the spring chamber.

Two additional flats are ground on the land at the end of the spool, which will allow fluid to flow into the spring chamber.

If there is a pressure spike in the system above the compensator setting, the spool will momentarily move to the over travel position in an effort to de-stroke the pump. Only position #2

(Fig. 5) is a true compensating condition. Do not become confused with the term “deadhead”, it means the same thing as compensating.

When the spring in the second stage is compressed, it will hold the poppet on its seat and block the flow to tank. With the flow blocked, the pressure at the bottom of the spool will be the same as the pressure at the top. Remember that pressure is equal throughout a static fluid. Since the area at the ends of the spool are equal, the hydraulic forces created are equal but opposite in direction and cancel each other out. To unbalance the forces, a light bias spring is added which pushes the spool into the bottomed-out position shown. With the spool in this position, system pressure is applied to the control piston and will push the ring on-stroke as it did in the single stage control.

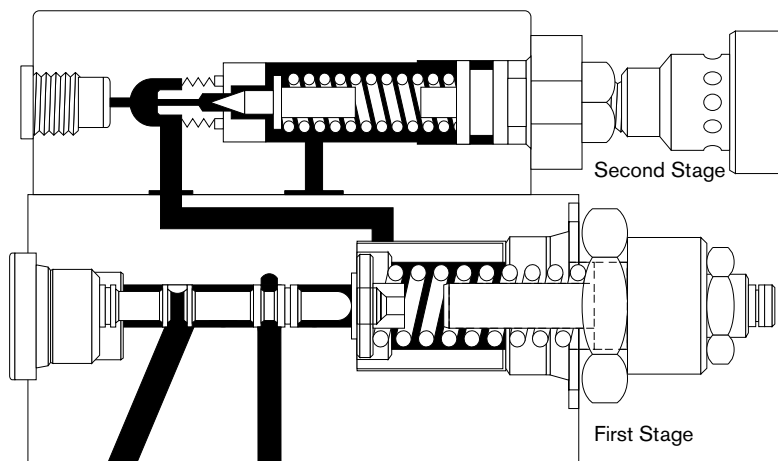

Fig. 6

Adjustment Procedures – Two-Stage Compensator

As system pressure increases, the pressure at the ends of the spool is always equal until it reaches the second stage setting. At that point the relief valve (second stage) will open and limit the pressure in the bias spring chamber by allowing fluid from the chamber to flow to tank. This will limit the amount of hydraulic force applied to the bottom end of the first stage spool. Fluid that is under pressure always takes the path of least resistance and, when the second stage opens, the entire pump flow is going to try to flow through the compensator to tank. To get to the tank, the fluid must flow through the very small flats ground on the end of the spool. As the entire pump flow tries to flow through the flats, they offer resistance to the flow, the pressure upstream of the flats is increased. This pressure is sensed at the top of the spool and, as the pressure increases, the hydraulic force pushing down on the spool increases. When this force becomes greater than the hydraulic force at the bottom, plus the bias spring force, the spool will be pushed towards the bias spring and vent the pressure behind the control piston to tank. The pump will then compensate as it did with the single stage control.

To set-up a two-stage compensator, follow the instructions given in Section 1 on how to set a thrust screw and differential setting. Once this is done, adjust and lock the compensator knob at the maximum compensating pressure of your system.

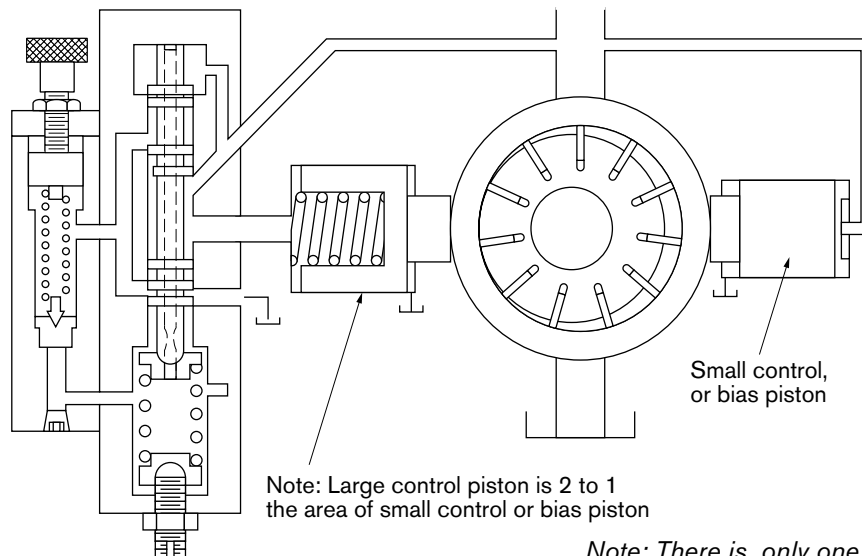
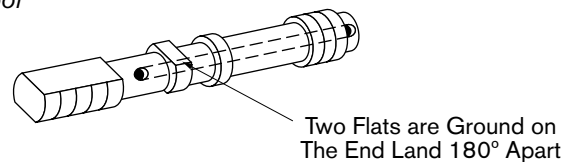

Fig. 7: Full Flow Position

Note: There is only one single common leakage connection common throughout in Fig. 7. The multiple leakage connections shown are only for functional representation.

Fig. 8: Two-Stage Compensator Spool



If servicing of the two-stage control is required, it is recommended to use the compensator seal kits identified in Table 5. Included in each compensator seal kit are all compensator O-rings, back-up rings a replacement poppet and poppet seat.

Table 5: Compensator Seal Kit for Two-Stage Compensator 3000 PSI

VPV	SAE	METRIC
16/25/32	9 511 230 627	9 511 230 628
45/63/80/100/130/164	9 511 230 660	9 511 230 661

Solenoid Two-Pressure Control

Multi-pressure pump control can markedly reduce horsepower demand and heat generation during periods of idle time or time in the machine operating cycle when maximum pressure is not required. The modular design of the standard two-stage compensator lends itself to variable preset multi-pressure control arrangements with integral or remotely located valving. Whenever remote relief valves and switching valves are used, care must be taken not to introduce too much contained fluid between the pump and the remote valving.

Severe reduction of the pump reaction time constants or erratic control may occur with lines of large size (larger than 1/4" O.D.T.) or of lengths exceeding 20 feet. Special circuits might be needed in certain cases to alleviate problems, including the use of orifices at each end of the remote line.

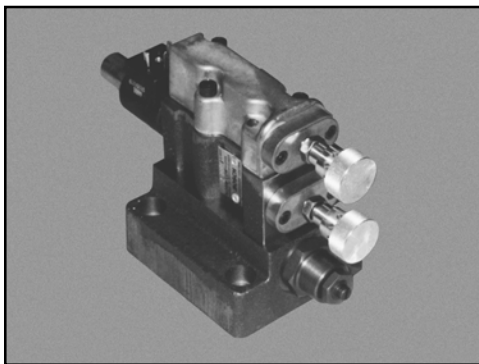

Fig. 9 shows the construction of the solenoid two-pressure compensator. The upper second stage is the high pressure control and serves to limit the maximum desired circuit pressure. The lower second stage contains either a normally open or normally closed two-way valve which is energized to select which of the two second stages will have control of the pump.

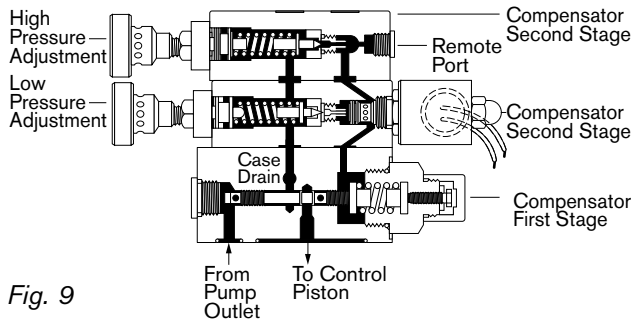

Fig. 9

Normally Open Valve Shown

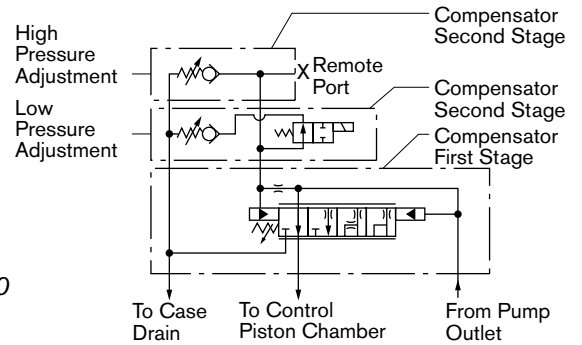

Fig. 10

Solenoid Two-Pressure Control

To adjust a solenoid operated two-pressure control, determine if the solenoid is normally open (N.O. means low pressure) or normally closed (N.C. means high pressure). The hydraulic code on the pump nametag will identify which type of solenoid is on the compensator, assuming that the pump and compensator have not been modified from the factory.

An example hydraulic code of a two-pressure control is: 0513R18C3VPV63SM21**X**AZB03. In this example, the **X** identifies the pump as a two-pressure compensator with a **normally open** solenoid. If the hydraulic code has a **Y** in this place, the solenoid is **normally closed**.

The solenoid must be closed to begin compensator adjustment. If the solenoid is normally closed, leave the solenoid de-energized. If the solenoid is normally open, energize the solenoid to close. Use the following steps to adjust the compensator:

1. Back out both the low pressure and high pressure adjusting knobs all the way.
2. Back out the first stage adjusting screw all the way.
3. Follow the procedure to set the thrust screw setting as detailed in Section 1, Proper Setting of the Thrust Screw.
4. Follow the procedure to set the first stage setting as detailed in Section 1, Proper Setting of the Thrust Screw.
5. With the solenoid closed, adjust the high pressure adjusting knob to set the maximum compensating pressure of the pump. Tighten the locknut on the adjusting screw to fix this pressure.
6. The solenoid must be opened to adjust the low pressure setting. After opening the solenoid (energize if N.C. or de-energize if N.O.), adjust the low pressure adjusting knob to set the second (i.e. low) pressure on the pump. Tighten the locknut on the adjusting screw to fix this pressure.

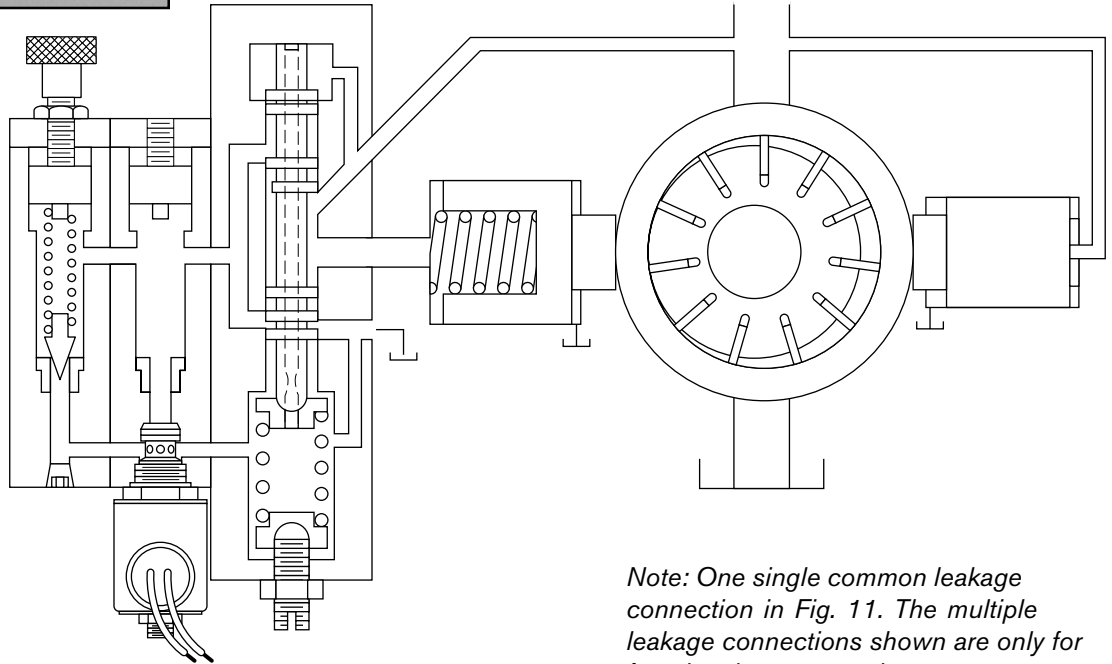
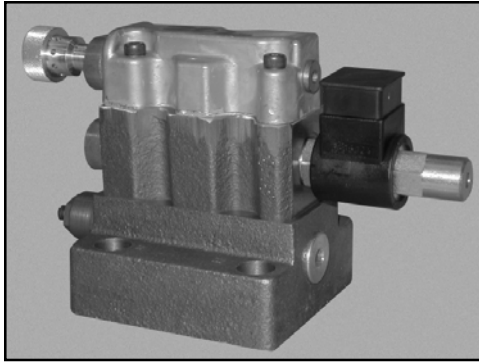
Solenoid Vented

Note: One single common leakage connection in Fig. 11. The multiple leakage connections shown are only for functional representation

Fig. 11

Figure 11 shows a hydraulic representation of a solenoid vented compensator. Once again, the solenoid must be closed to begin compensator adjustment.

Using the hydraulic code on the pump, determine if the solenoid is normally open or closed. An example hydraulic code of a solenoid vent is: 0513R18C3VPV63SM21ZAZB03. In this example, the **Z** identifies the pump as a solenoid vented compensator with a **normally open** solenoid. If the hydraulic code has a **W** in this place, the solenoid is **normally closed**.

If the solenoid is normally closed, leave the solenoid de-energized. If the solenoid is normally open, energize the solenoid to close. Use the following steps to adjust the compensator:

1. Back out the high pressure adjusting knob all the way.
2. Back out the first stage adjusting screw all the way.
3. Follow the procedure to set the thrust screw setting as detailed in Section 1, Proper Setting of the Thrust Screw.
4. Follow the procedure to set the first stage setting as detailed in Section 1, Proper Setting of the Thrust Screw.
5. With the solenoid closed, adjust the high pressure adjusting knob to set the maximum compensating pressure of the pump. Tighten the locknut on the adjusting screw to fix this pressure.
6. To check the solenoid vent pressure, the solenoid must be opened. After opening the solenoid (energize if N.C. or de-energize if N.O.), the system pressure should decrease to the first stage setting.

Load Sense (Flow Control)

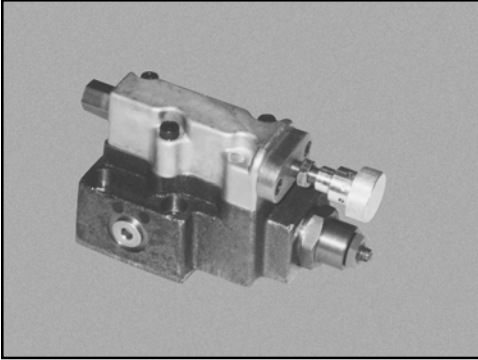

The purpose of the load sensing flow control is to maintain constant flow regardless of changes in load or pump shaft rotational speed. This is accomplished by using an external metering valve and continually sensing pressure drop across this valve with a pilot line. The pump becomes a “control element” with this option, very similar to a very accurate pressure compensated flow control. However, because manipulation of the hydraulic power source is extremely efficient and the pump only uses precisely enough pressure to accomplish the task, the load sensing flow compensator (LSFC) is very energy conserving. Accuracy of the LSFC is +2-5% of set flow rate

over the full range of load pressure. A changeable orifice is installed as standard and built into the compensator body.

The two-stage pressure compensator module is the basic foundation for the LSFC. The control seeks to maintain a constant pressure drop across a remote orifice. Any increase in flow due to decreasing load or increase in pump shaft rpm will cause an increase in the differential pressure. The VPV load sense P is factory set at 100 PSI (7 bar) for VPV 16–80 pumps and 200 PSI (14 bar) for VPV 100–164 pumps. The opposite control action occurs smoothly should the P fall below this differential setting, dynamically changing ring position to adjust for any differential pressure changes. Constant velocity of the load under widely varying pressure conditions results.

Should the load stall or otherwise be restricted from movement or use of fluid, the pressure compensator as secondary control will take over and maintain maximum deadhead pressure until the problem is corrected. Should the remote valve be totally closed, the pump will go to minimum deadhead.

The sensing pilot line P1, which is downstream, connects to the compensator as shown. A #4 SAE connector for P1 has a 0.040" orifice in it to dampen out any tendency to oscillate for sense lines of 1/4" tubing up to 8 feet long. Additional 0.030" orificing in each line might be necessary for longer lines. Sense lines should be hard tubing of approximately equal length and 1/4" diameter tapped into the main line, at least 10 pipe diameters upstream and downstream of the remote orifice. If located too close to the remote orifice, turbulent flow might create erratic action. Thorough air bleeding of the sense lines is absolutely essential to proper operation.

The quality of the remote valve is very important to the accuracy and stability of the LSFC. Successful valves are:

1. Standard flow control valves.
2. Electrohydraulic proportional flow controls of many types.

Load Sense (Flow Control)

All orifices must be non-pressure compensated and sharp edged for temperature stability. If only low accuracy is needed, the P of a four-way valve or other two-way is generally useable. Remember that at least 100 PSI (200 PSI for VPV 100–164) P must be developed at the minimum flow rate or the LSFC will not work well.

Figure 13, on following page, is the schematic for the LSFC plus a flow versus pressure characteristic curve. The curve shows that two areas (shaded) must be avoided! (30-60 CIPM is the normal control flow required). First, flow rates below 10% of maximum output at rated rpm and second pressures below minimum deadhead (generally 400 PSI on 3000 PSI rated pumps). Flat flow lines extend from minimum deadhead to approximately 100 PSI below the setting of the pressure compensator, at any flow rate within the limits of maximum to 10% of maximum capability.

The LSFC is intended for and should be applied on meter-in circuits only. Meter-out circuits could pose serious safety problems or design difficulties because of the P1 sense line location downstream of the orifice. This puts P1 at atmospheric or at tank line pressure, which can vary drastically. Please do not apply LSFC-equipped pumps on meter-out circuits until the factory advises otherwise.

The procedure to set-up a load sense control is essentially the same as the procedure to set-up a two-stage control. The differential setting (first stage adjustment) must be set to a minimum of 100 PSI (200 PSI for VPV 100–164 pumps) above the thrust screw setting. This P can be increased to 200 PSI (14 bar) for better operation, but this higher differential setting does increase the minimum compensating pressure at which the pump can operate at. Therefore, the higher differential setting should only be used if low pressure compensating is not a concern for your system.

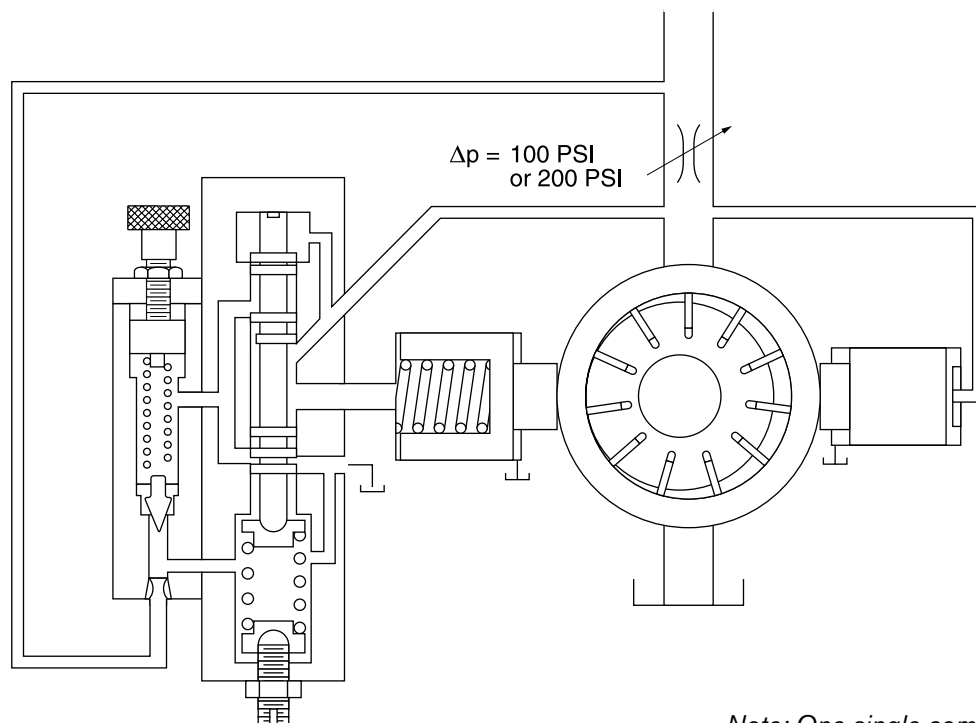

Note: One single common leakage connection in Fig. 12. The multiple leakage connections shown are only for functional representation

Fig. 12

Load Sense (Flow Control)

Load Sensing Flow Compensator Control

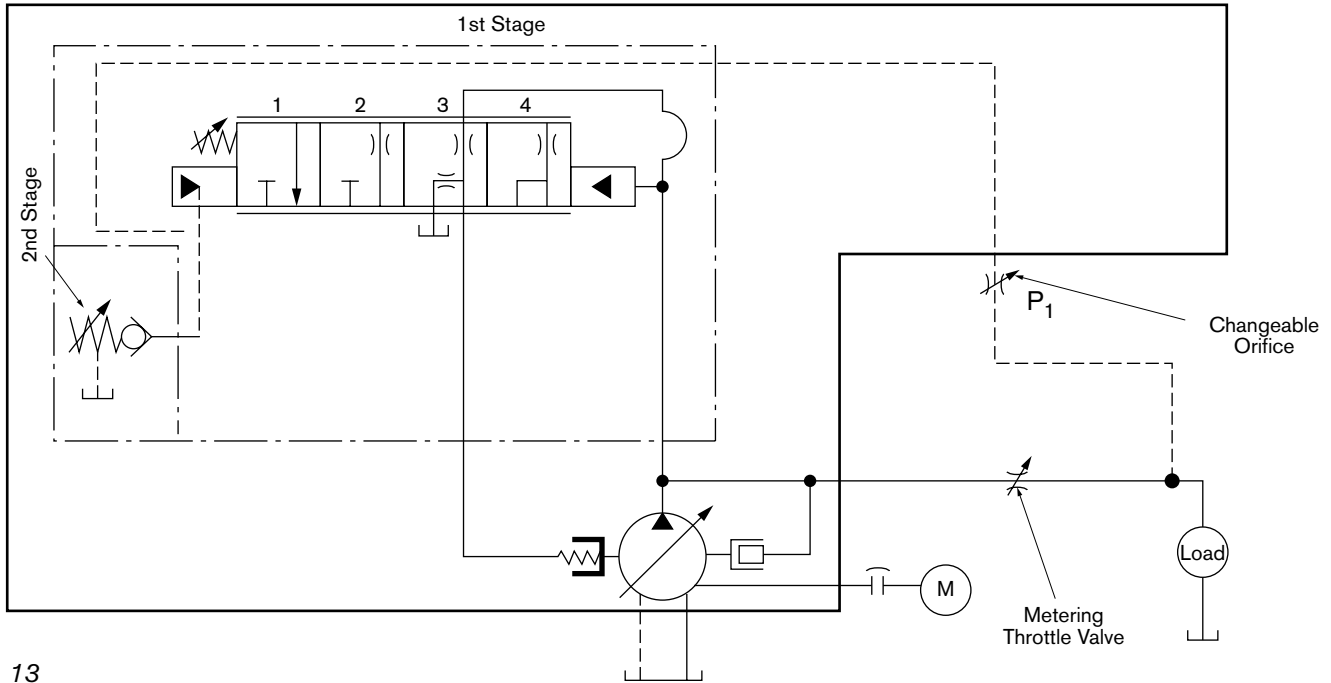

Fig. 13

Table 6:

LSFC Condition	Valve Position	Condition	System Condition
Rated P	3	On stroke to set flow	Constant flow close deadhead
Above Rated P	4	Minimum deadhead	External orifice shut off
Below Rated P	2 to 1	Full deadhead	External orifice open beyond pump displacement
Zero P	3 to 4 Comp. Override	Deadhead	Load resistance above compensator setting

LSFC Flow vs. Pressure Characteristic Curves

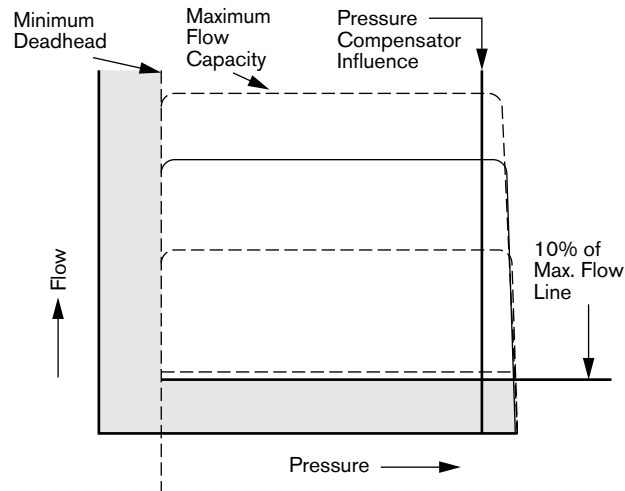
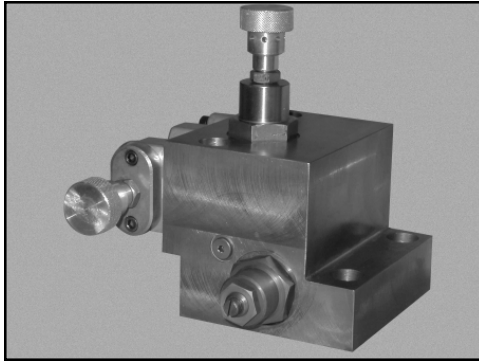

Fig. 14

Torque Limiter



The torque limiter control option is only available on VPV 45–164 pump sizes.

At this time point in time, torque limiting compensators are only available with SAE connections. Torque limiting controls featuring BSPP connections may be offered in the future. If your application requires BSPP connections, please contact the factory for availability.

The torque limiter control has two customer settable adjustments.

The second stage pressure adjustment (knurled knob parallel to inlet/outlet ports) is used to set the maximum deadhead pressure of the pump. A family of pressure cut-off curves, Fig. 15, are achievable using this adjustment. Clockwise adjustment increases the maximum deadhead pressure, while counter-clockwise adjustment decreases the maximum deadhead pressure.

The torque limiter adjustment (knurled knob perpendicular to the inlet/outlet ports) is used to set the torque cut-off curves. A family of torque cut-off curves, Fig. 16 and Fig. 17, are achievable using this adjustment. Clockwise adjustment increases the torque cut-off point, while counter-clockwise adjustment decreases the torque cut-off point.

Fig. 15 shows that it is possible to use a torque limiter control as a standard two-stage pressure compensator up to the maximum full-flow pressures as shown in Table 7.

Table 7: Maximum Full Flow Pressure

VPV	PSI (Bar)	
45	2250	(155)
63	2250	(155)
80	1750	(121)
100	2250	(155)
130	2250	(155)
164	1500	(103)

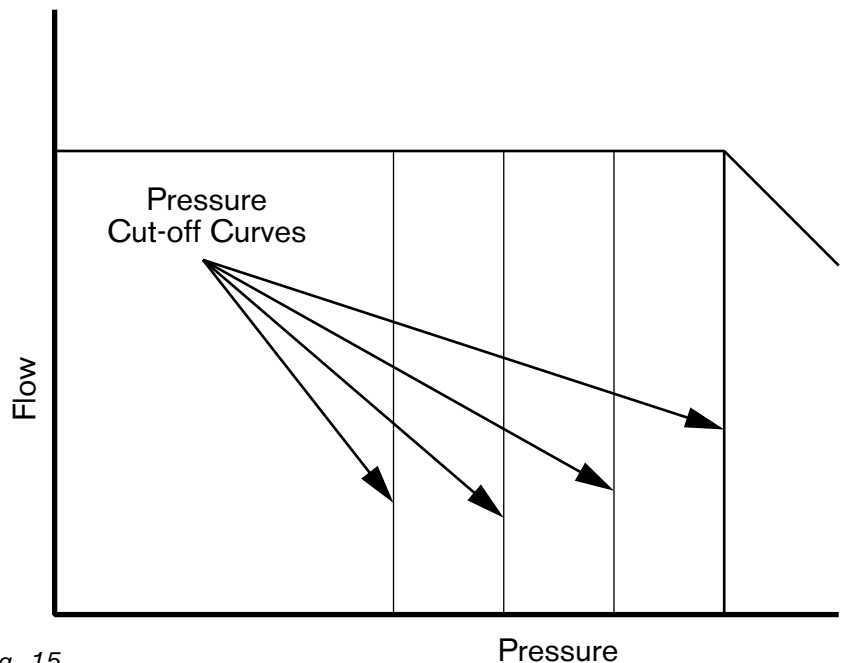

Fig. 15

Torque Limiter

Fig. 16 shows that the second stage pressure adjustment (pressure cut-off curve) will over-ride the torque limiter adjustment (torque cut-off curve) when the two intersect. This feature limits the maximum pressure of the pump.

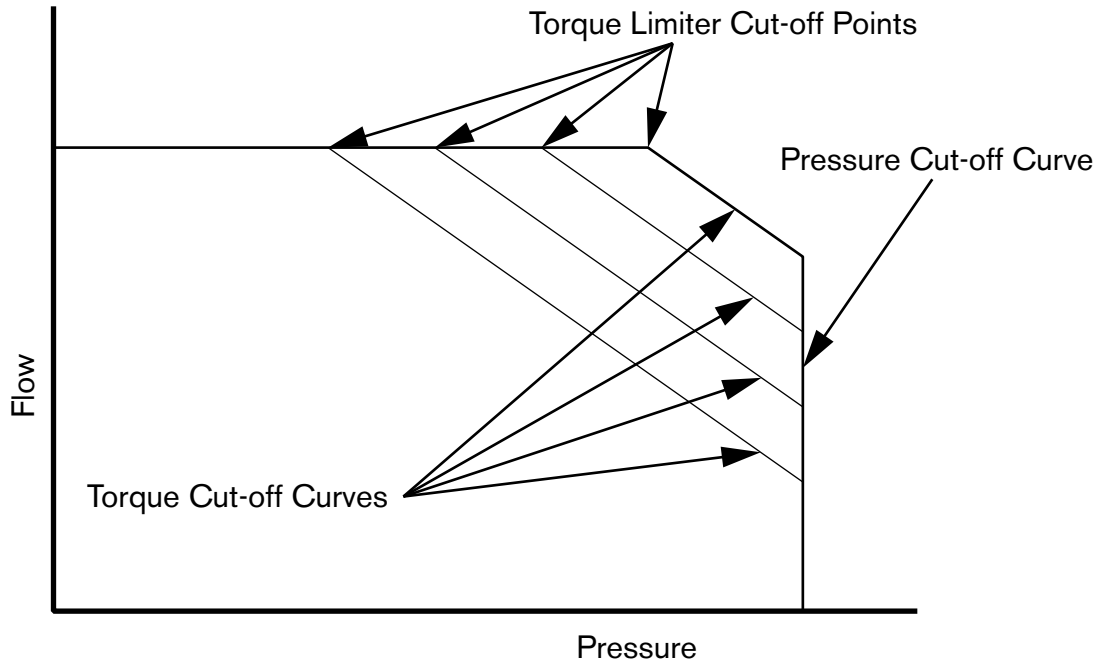

Fig. 16

Fig. 17 shows that it is possible to set the torque limiter cut-off point to a level where the pressure cut-off curve is not reached. In this case, the maximum deadhead pressure is limited by the torque limiter cut-off adjustment. It can also be seen that the torque limiter cut-off point can be set to a level where maximum output flow of the pump can not be achieved.

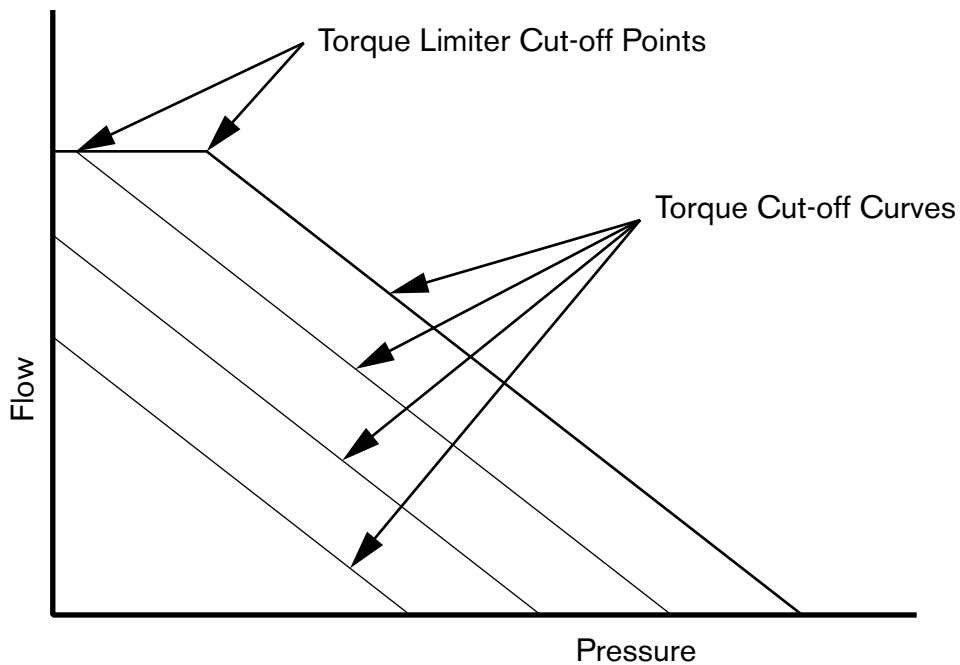

Fig. 17

Torque Limiter

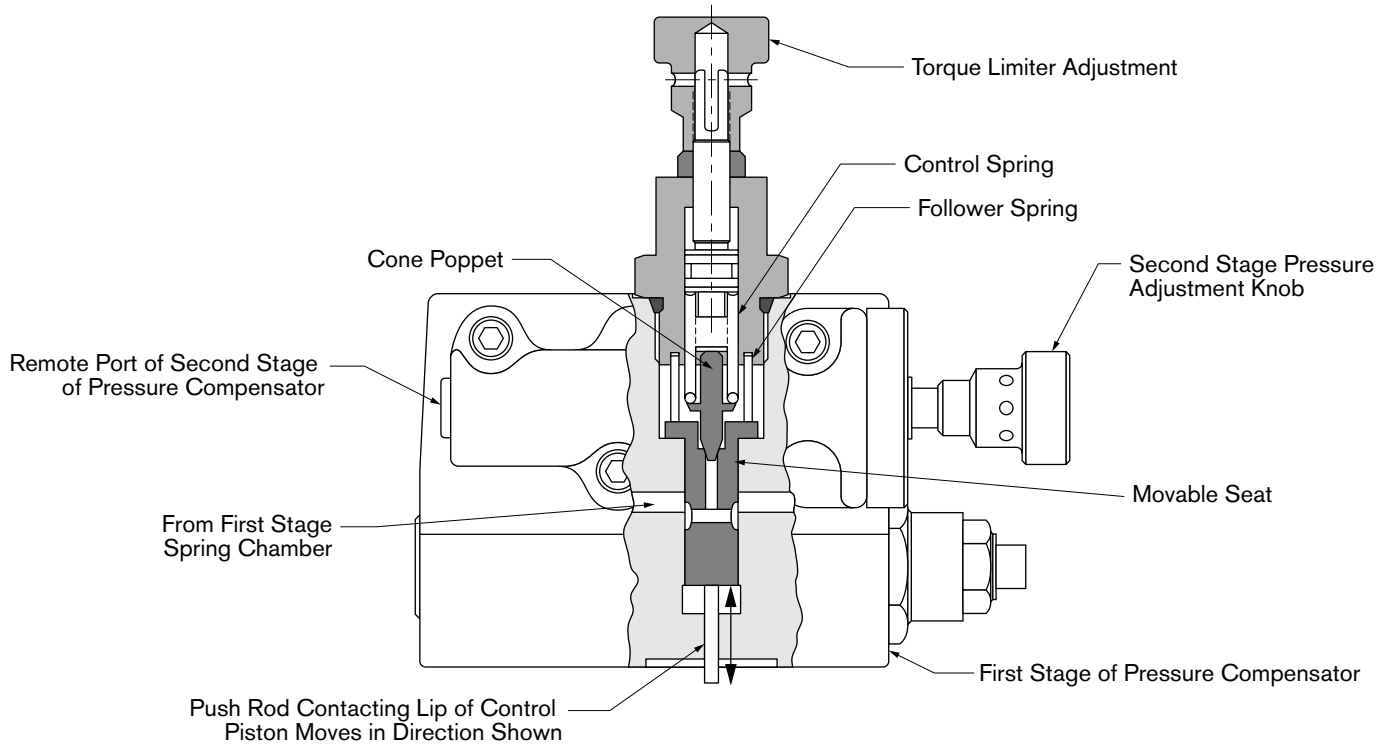

Fig. 18

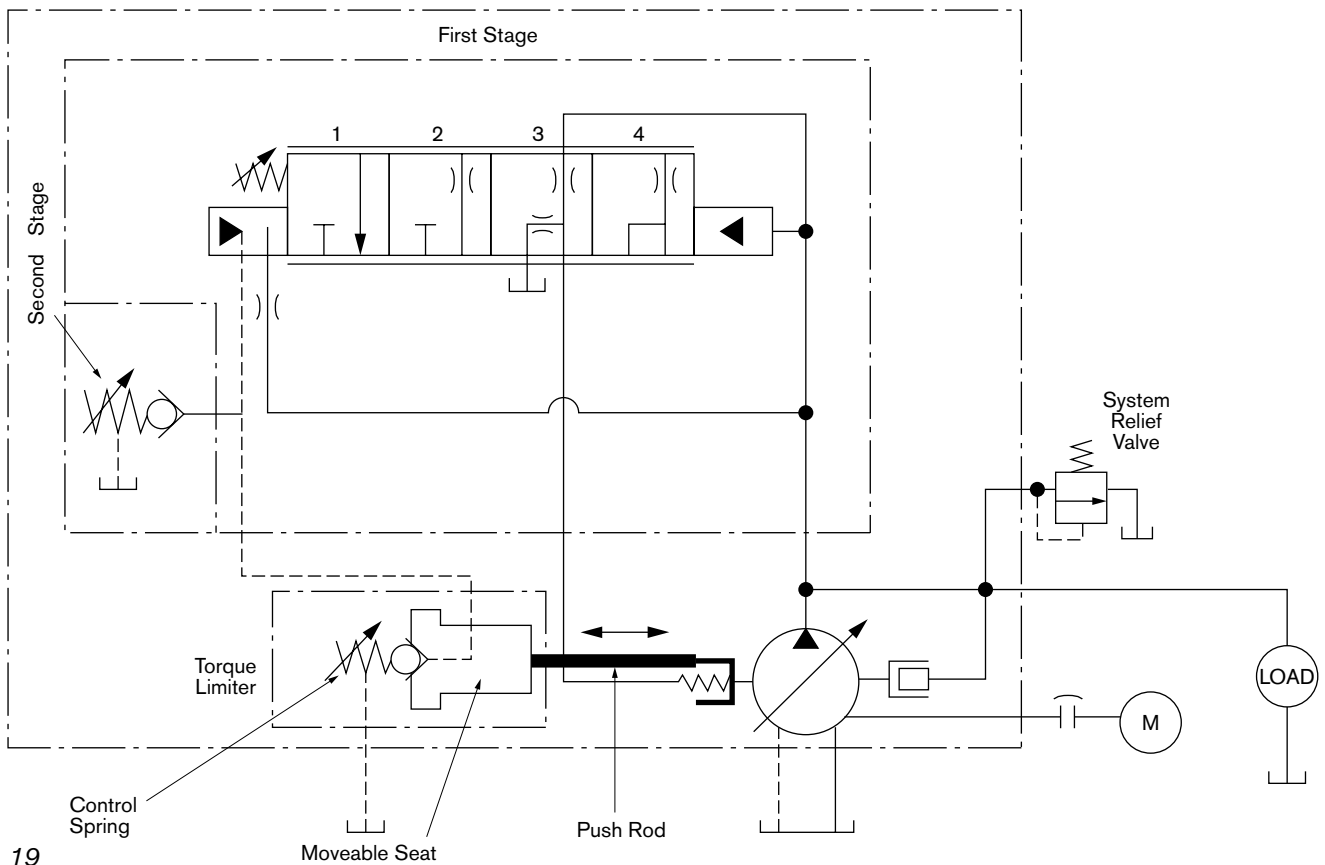

Fig. 19

Torque Limiter

Table 8:

Torque Limiter	Spool Position	Pump Condition	System Position
Poppet Seated	1	Free Flow	No Resistance
Poppet Opening	2	Full Flow	Resistance Starting
Poppet Metering	2 to 3	Reduced Stroke	Resistance Increasing
Poppet Metering	3	Deadhead	Blocked
Poppet Open	4	Spool Over Travel	Shock Pressure Above Deadhead

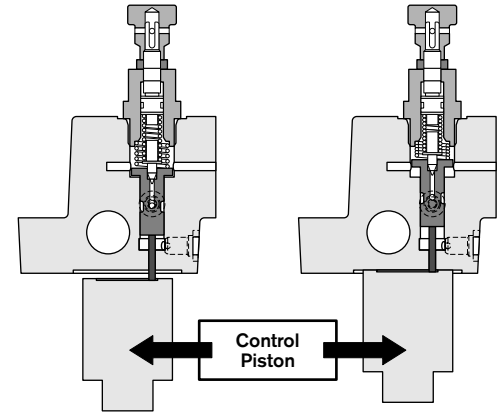

Fig. 20

Setting the Maximum Deadhead Pressure (Second Stage Setting)

Caution: VPV torque limiter adjustment stems that have the adjustment knob removed pose special concerns when the pump is re-started. Some internal control components can be damaged if the torque limiter is not adjusted properly. Please consult the factory if this condition exists.

1. If you received a pump straight from the factory, please skip to step 7. Otherwise, proceed with the following steps.
2. Before starting the pump, complete the following operations.
 - Back-out (counter-clockwise) the second stage of the compensator all the way.
 - Turn the torque limiter adjustment knob fully out (counter-clockwise).
3. Start the pump running into an open circuit under minimal load and at normal operating temperature.
4. If the pump does not prime, turn the thrust screw clockwise in small increments until the pump primes.
5. Close a load valve in the circuit such that the pump has no output flow (i.e. deadhead condition).
6. Follow the instructions given in Section 1 on how to set the proper thrust screw setting and first stage differential setting.
7. Torque limiter pumps straight from the factory should already have the proper thrust screw and first stage settings. With the pump operating in deadhead, turn the torque limiter adjustment knob fully in (i.e. clockwise). This will set the torque limiter function out of the way such that second stage pressure adjustment can be made.
8. Adjust the second stage pressure adjustment to the desired maximum deadhead pressure and lock in place with the jam nut. Proceed to setting the torque limiter adjustment.

Torque Limiter

Setting the Torque Limiter

1. With the pump still in deadhead, adjust the torque limiter knob out (counter-clockwise) as follows:
VPV45, VPV80, and VPV164 1½ full turns CCW
VPV63, VPV100, and VPV130 2 full turns CCW
2. Turning the torque limiter adjustment out by this amount will assure a low torque setting when the circuit is opened.
3. Take the pump out of deadhead by opening the circuit.
4. Load the hydraulic circuit and check to see if the desired flow/pressure/torque requirements of your system are achieved.
5. To adjust the torque limiter settings, turn the torque limiter adjustment knob in for higher torque and out for less torque in small increments.
6. Continue this process until the desired conditions are achieved.
7. Lock the jam nut under the torque limiter knob.

Application Notes:

1. When the torque limiter adjustment is fully backed out or near its lowest setting, the pump may not reach full flow.
2. Putting a flow and pressure load on the pump with the torque limiter adjusted fully in may cause the pump motor to stall or be damaged if the motor is undersized for full flow and high pressure.
3. It is possible for the torque limiter to control the maximum deadhead pressure of the pump. This condition can occur if the torque limiter curve reaches zero output flow before the second stage maximum deadhead pressure is achieved.

VPV Compensator Part Numbers

	Control Code	3000 PSI (210 BAR)				2000 PSI (140 BAR)			
		VPV16-32 SAE	VPV45-164 SAE	VPV16-32 ISO	VPV45-164 ISO	VPV16-32 SAE	VPV45-164 SAE	VPV16-32 ISO	VPV45-164 ISO
Single Stage	F	9511230595	–	9511230596	–	9511230513	9511230548	9511230512	9511230548
Single Stage Lockable	G	–	–	9511230710	–	–	–	–	–
Two Stage	H	9511230601	9511230610	9511230602	9511230611	9511230514	9511230550	9511230515	9511230551
Second Stage Only (H control)		9511230698	9511230698	9511230697	9511230697	–	–	–	–
Two Stage Lockable	HL	9511230752	9511230751	–	–	–	–	–	–
Second Stage Lockable Only (HL control)		9511230750	9511230750	–	–	–	–	–	–
Load Sense	J	9511230603	9511230612	9511230604	9511230613	9511230600	9511230589	9511230690	9511230588
Second Stage Only (J control)		–	–	9511230762	9511230762	–	–	–	–
Solenoid Two-Pressure Complete Controls									
N.O., 115VAC, DIN connector	XA	–	–	–	–	9511230555	–	–	–
N.O., 12VDC, DIN connector	XC	–	–	–	–	9511230614	–	–	–
N.O., 24VDC, DIN connector	XD	9511230699	–	–	–	–	9511230630	–	–
N.O., 115VAC, flying leads	XE	9511230672	9511230671	–	–	9511230662	9511230629	–	–
N.O., 12VDC, flying leads	XG	–	–	–	–	9511230553	–	–	–
N.O., 24VDC, flying leads	XH	9511230668	–	–	–	9511230663	–	–	–
N.C., 115VAC, DIN connector	YA	9511230677	–	–	–	–	9511230637	–	–
N.C., 24VDC, DIN connector	YD	9511230678	–	–	–	–	–	–	–
Solenoid Two-Pressure Sandwich Module Only									
N.O., 115VAC, DIN connector	XA	–	–	–	–	9511230669	9511230669	9511230669	9511230669
N.O., 24VDC, DIN connector	XD	–	–	–	–	9511230670	9511230670	9511230670	9511230670
N.O., 115VAC, flying leads	XE	9511230679	9511230679	9511230679	9511230679	–	–	–	–
N.O., 230VAC, flying leads	XF	9511230704	9511230704	9511230704	9511230704	–	–	–	–
N.O., 24VDC, flying leads	XH	–	–	–	–	9511230593	9511230593	9511230593	9511230593
N.C., 115VAC, DIN connector	YA	9511230688	9511230688	9511230688	9511230688	–	–	–	–
N.C., 115VAC, flying leads	YE	9511230696	9511230696	9511230696	9511230696	–	–	–	–
Solenoid Vent Complete Controls									
N.O., 115VAC, DIN connector	ZA	–	–	–	–	–	9511230617	–	–
N.O., 24VDC, DIN connector	ZD	9511230719	–	–	–	–	–	–	–
Solenoid Vent Sandwich Module Only									
N.O., 115VAC, DIN connector	ZA	9511230683	9511230683	9511230683	9511230683	–	–	–	–
N.O., 24VDC, DIN connector	ZD	9511230686	9511230686	9511230686	9511230686	–	–	–	–
N.O., 115VAC, flying leads	ZE	9511230735	9511230735	9511230735	9511230735	–	–	–	–

	Control Code	VPV16	VPV25	VPV32	VPV45	VPV63	VPV80	VPV100	VPV130	VPV164
Torque Limiter (SAE Only)	S	Not Available	Not Available	Not Available	9511230713	9511230714	9511230715	9511230708	9511230700	9511230716
Proportional Pressure	VA									
180 bar, 2.5 Amp Valve		9511230711	9511230711	9511230711	–	–	–	–	–	–
250 bar 800 mAmp Valve		–	–	–	9511230712	9511230712	9511230712	9511230712	9511230712	9511230712
315 bar 2.5 Amp Valve		–	–	–	9511230703	9511230703	9511230703	9511230703	9511230703	9511230703
P/Q Electrohydraulic	T	Not Available	Not Available	Consult factory	Consult factory	Consult factory	Consult factory	Consult factory	Consult factory	Consult factory

Additional Notes:

All control and sandwich module kits that have 9511 numbers are pre-tested and include the necessary o-rings and bolts to mount the control to the pump.

Seal kits especially for F and H style compensators are referenced in Sections 2 and 3.

2000 and 3000 psi versions define the pressure at which the controls are tested and pinned at for maximum pressure.

Additional control kits may be developed upon request. Consult factory in these situations.

Bosch Rexroth Corporation
Industrial Hydraulics Division
7505 Durand Avenue
Sturtevant, Wisconsin 53177
Phone (262) 554-7100
Fax (262) 554-7117
Email: webmasterbrirc
@boschrexroth-us.com
www.boschrexroth-us.com

Bosch Rexroth Corporation*#
Pneumatics
P.O. Box 13597
1953 Mercer Road
Lexington, KY 40511-1021
Phone (859) 254-8032
Fax (859) 254-4188
(800) 489-4188
Email: customer.pneumatics
@boschrexroth-us.com
www.boschrexroth-us.com

Bosch Rexroth Corporation
Electric Drives and Controls
5150 Prairie Stone Parkway
Hoffman Estates, IL 60192-3707
Phone (847) 645-3600
Fax (847) 645-6201
Email: info@indramat.com
www.boschrexroth-us.com

Bosch Rexroth Corporation
Linear Motion and
Assembly Technologies
816 East Third Street
Buchanan, MI 49107
Phone (616) 695-0151
Fax (616) 695-5363
www.boschrexroth-us.com

Bosch Rexroth Corporation*
Mobile Hydraulics Division
P.O. Box 395
1700 Old Mansfield Road
Wooster, OH 44691-0394
Phone (330) 263-3300
Fax (330) 263-3333
Email: info@rexroth.com
www.boschrexroth-us.com

Bosch Rexroth AG
Zum Eisengiesser 1
D-97816 Lohram Main
Telefon +49 (0) 93 52/18-11
Fax +49 (0) 93 52/18-11 90
Email: pr@rexroth.de
www.boschrexroth.de

*ISO9001 Certified Quality System
#QS9000 Certified Quality System

For more information, you may contact your nearest Bosch Rexroth distributor: