



BOSCH

REPAIR PARTS

VARIABLE VOLUME SILENTVANE PUMPS

MODEL SV10 **2000 PSI**
 7.5 GPM

MODEL SV15 **1500 PSI**
 11 GPM

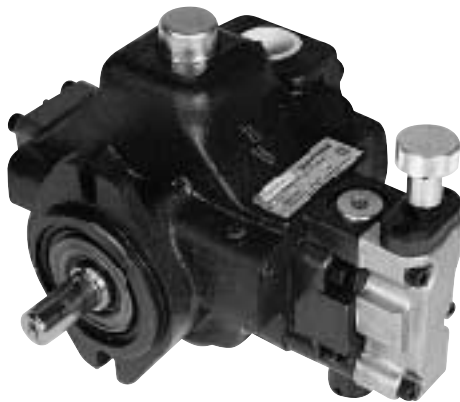

MANIFOLD MOUNTED FLANGE MOUNTED COMBINATION CAPABILITY

When ordering parts, furnish:

1. Complete code number
2. Parts required
3. Shipping instructions

Write factory or visit our website at www.boschfluidpower.com for nearest authorized parts and service center.

PUMP CODING

PSV-PNSF-10HRM-52

J - Hydraulic Two-Pressure Control
(normally low, energized
to high pressure)

K - Single Stage

L - Load Sensing Flow Control

P - Pressure Compensator (STD)

S - Solenoid Two-Pressure Control
(normally low energized
to high pressure)

T - Torque Limiting Control

N - No Volume Control

S - Screw Volume Control

S - Subplate

A - Flange, Side Ported
(SAE Straight Thread)

B - Flange, Rear Ported
(SAE Straight Thread)

F - Viton Seals

Flow Rate @ 1800 RPM

10 - 7.5 GPM

15 - 11 GPM

Pressure Rating Max.

H - 2000 PSI

E - 1000 PSI (SV15 only)*

D - 750 PSI

50/60 - Original Design/
Combination Pump

51/61 - 2nd Stage Update

52/62 - 1st & 2nd Stage Changes

53/63 - Sol. 2-Press. Control Only

54/64 - Low Noise Port Plates

55/65 - Modified Vane Tip Profile

56/66 - New Port Plate Coating

M - Medium Keyed Shaft

D - Thru Keyed Shaft

W - Keyed Shaft (Metric)

R - Right Hand Rotation

Q - Left Hand Rotation

Opposite Drive Shaft - Manifold Mounted

*1500 PSI Maximum Intermittent
Pressure (non-shock)

MANIFOLD MOUNTING RIGHT HAND ROTATION PUMP SHOWN WITH MEDIUM KEYED SHAFT

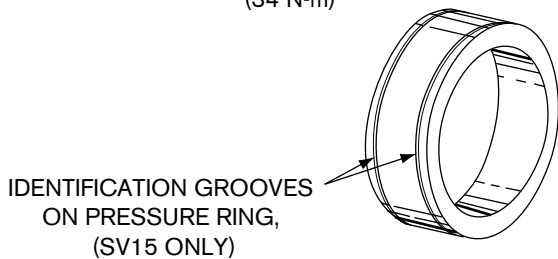
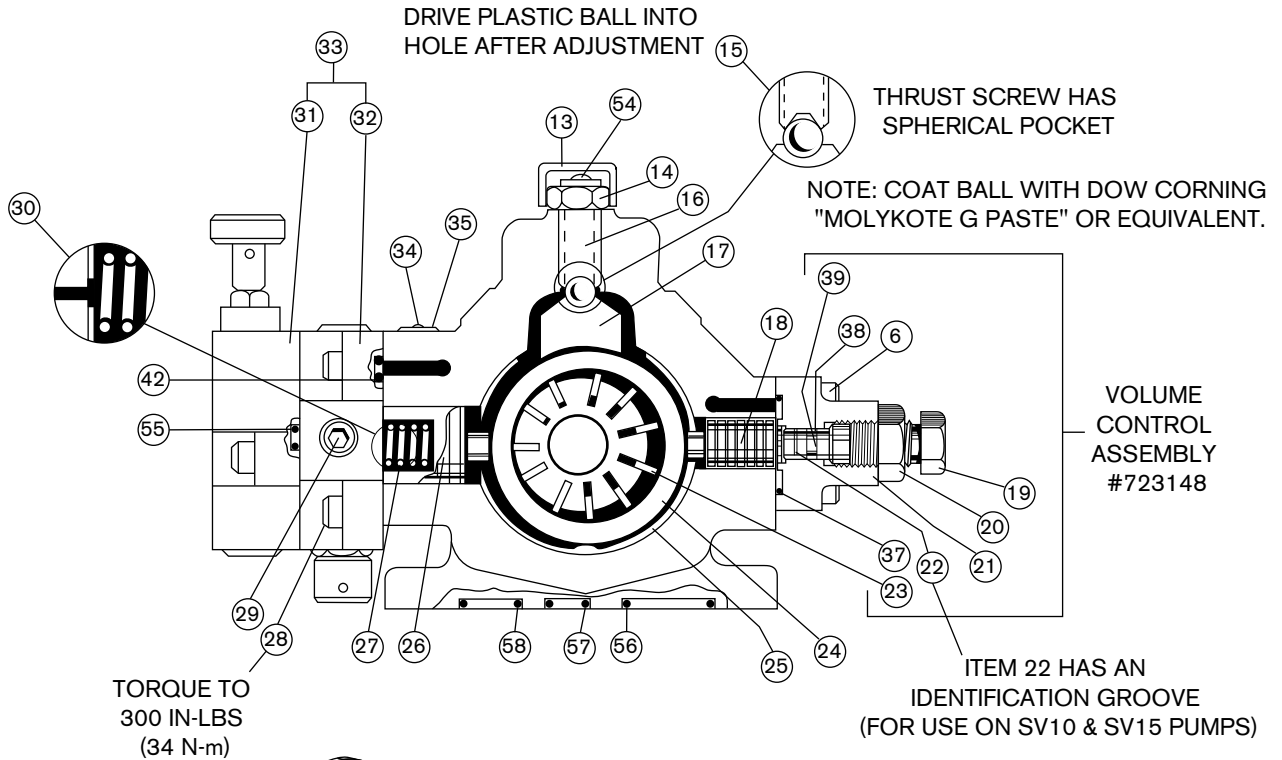
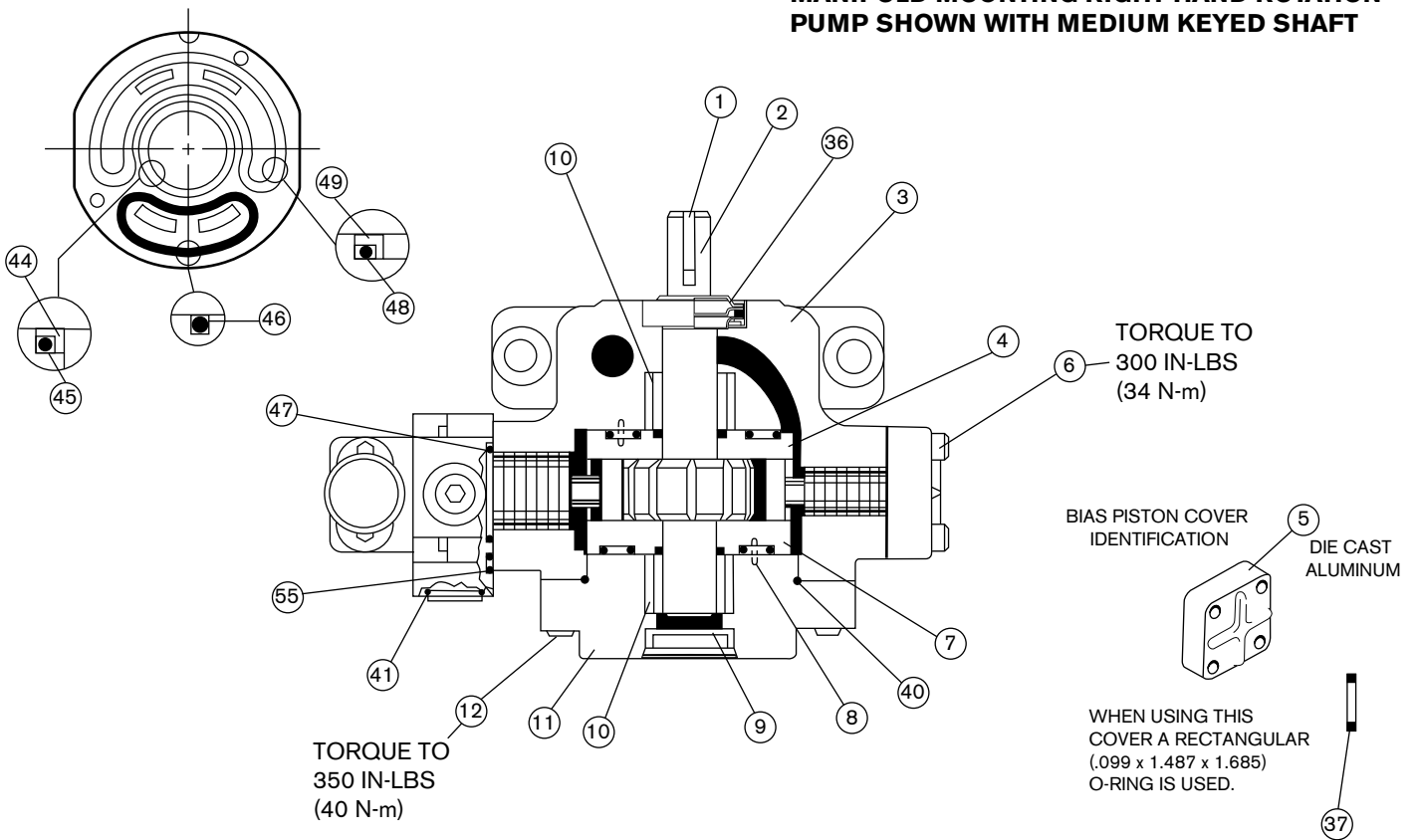

IDENTIFICATION DIMPLES ON SPACER RING (SV15 ONLY)

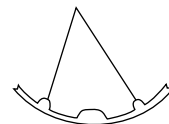

Ref. No.	Part No.	Description	Qty.
1	408128	Key	1 or 2
2	308333	Rotor Shaft, Standard	1
2	308334	Rotor Shaft, Thru (-56 design)	1
2	308985	Rotor Shaft, Combination (-66 design)	1
3	222832	Body, Subplate Mounted (-56 design)	1
3	222868	Body, Flange Mounted (-66 design) RH -	1
4	223235	Port Plate, Body	1
5	492010	Bias cover, Die Cast Aluminum	1
6	400789	Screw, 5/16-18 x 1-1/4	4
7	223237	Port Plate, Cover	1
8	401712	Roll Pin	4
9	490778	Expansion Plug (-56 design)	1
10	778355	Sleeve & Bearing Assembly	2
11	222834	Cover, Subplate Mounted (-56 design)	1
11	222931	Cover, Rear Ported SAE (-66 design)	1
11	222989	Cover, Side Ported SAE (-66 design)	1
12	400809	Screw, 3/16-16 x 1-1/2	4
13	490775	Cap, Thrust Screw	1
14	401015	Lock Nut, 5/8-18	1
15	401069	Steel Ball	1
*16	308701	Thrust Screw	1
17	490768	Thrust Block	1
18	308329	Bias Piston	1
19	308127	Adjusting Screw	1

Ref. No.	Part No.	Description	Qty.
20	401016	Lock Nut	1
21	222524	Body, Volume Control	1
22	308322	Piston	1
23	778277	Vane (309203) 11 - Vane Kit	1
24	308330	Pressure Ring	1
24	308666	Pressure Ring (SV15 only)	1
25	308331	Spacer Ring	1
25	308700	Spacer Ring (SV15 only)	1
26	308129	Control Piston	1
27	408717	Spring	1
**28	400789	Screw, 5/16-18 x 1-1/4	4
28	491838	Screw, Ferry Head, 5/16-18 x 1-1/4	4
29	491832	Plug, #8 SAE	1
30	492742	Shim (SV15 only)	1
31	-	Second stage of two-stage compensator	1
32	-	First stage of two-stage compensator	1
33	-	Assembly, two-stage compensator	4
34	491865	Rivet, Nameplate	2
35	491854	Nameplate	1
-	400925	Plug, 1/16 N.P.T.F. (Not shown)	4
50	492568	Gasket (Viton)	1
51	222975	End Cover	1
52	407799	Washer	2
53	400721	Screw, 3/8-16 x 7/8	2
54	492143	Plastic Ball	1
***59	406618	Plug, #4 SAE (Gage Port)	1

* Included in seal kits used for both SV10 and SV15.

** On standard Compensated and Load Sensing Compensating Pumps, this screw is used to mount the 1st stage to the pump body. All other optional compensators or controls use 491838 ferry head cap screws.
CAUTION: Do not over torque.

*** Not shown.

SEAL KIT (VITON)

SV10/15 **Single** End Shaft Pumps: Kit #778358

SV10/15 **Through** Shaft Pumps: Kit #778364

Ref. No.	Part No.	Description	Qty.
36	794467	Shaft Seal Assembly (457614)	1 or 2
37	492122	O-Ring, Rectangular (Aluminum Cap)	1
37	406513	O-Ring, 3/32 x 1-9/16 x 1-3/4 (-129) (Ductile Cap)	1
38	408846	Back-up Ring	1
39	406269	O-Ring, 1/16 x 3/8 x 1/2 (-012)	1
40	491015	O-Ring, 3/32 x 3-3/4 x 3-15/16 (-154)	1
41	407139	O-Ring, #8 SAE (-908)	2
42	406797	O-Ring 1/16 x 5/16 x 7/16 (-011) (Used with powered metal body)	1
42	406565	O-Ring, 1/16 x 7/16 x 9/16 (-013) (Used with the iron body)	1
44	490746	Back-up Ring	2
45	409156	O-Ring, 1-1/4 x 1-3/8 x 1/16 (-026)	2
46	406711	O-Ring, 1-7/16 x 1-5/8 x 3/32 (-127)	2

NOTE: Kit #778364 consists of 1 piece: 778358 and 1 piece: 794468.

Ref. No.	Part No.	Description	Qty.
47	407105	O-Ring, 1/16 x 1-1/2 x 1-5/8 (-029)	1
48	491016	O-Ring, 3/32 x 3 x 3-3/16 (-151)	2
49	491812	Back-up Ring	2
55	406797	O-Ring, 1/16 x 5/16 x 7/16 (-011)	4
56	407148	O-Ring, 3/32 x 1-3/8 x 1-3/16 (-123)	1
57	406518	O-Ring, 3/32 x 3/4 x 9/16 (-113)	1
58	406555	O-Ring, 3/32 x 1 x 13/16 (-117)	1
***	406579	O-Ring, 3/32 x 7/16 x 5/8 (-111)	1
***	407141	O-Ring, (-904)	2
***	407138	O-Ring, #10 SAE (-910)	1
***	490418	Back-up Ring	1

*** Shown on pages 5, 6, and 7.

REPAIR KITS

Description	Design Digit	Assembly No. SV10	Assembly No. SV15
Std. Medium Keyed Shaft - Viton	-50 thru -66	794107	794110
Double-ended Shaft - Viton	-50 thru -56	794109	794111
Combination Shaft - Viton	-60 thru -66	794395	794397

NOTE: Each kit contains the following parts: one rotor shaft, one key, one set of vanes, four roll pins, two port plates, two bearings, one pressure ring and one seal kit.

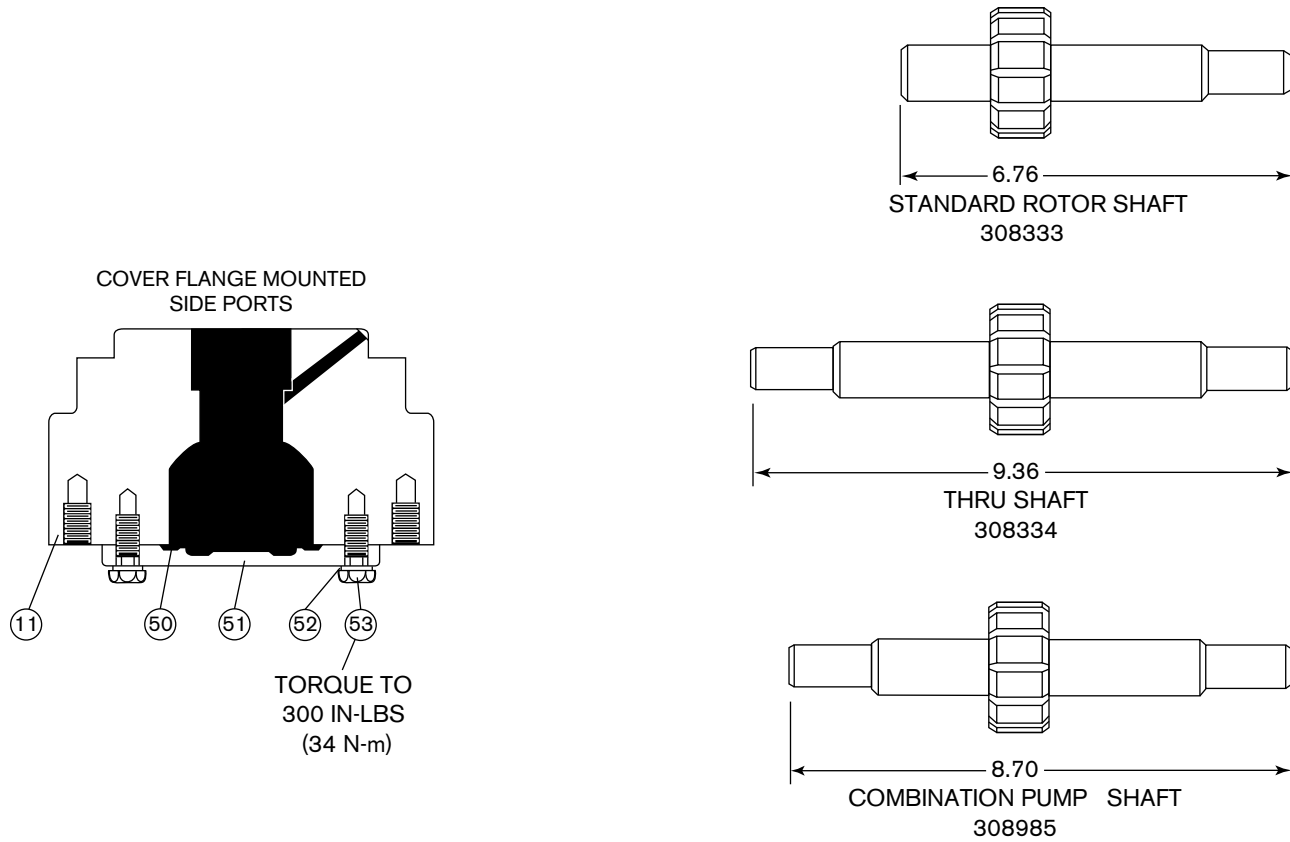

ADAPTOR/COUPLING SYSTEM

The distance from the pump mounting flange to the center of the port, increased by 3/8" (SV10 and SV15).

**PORT CHANGES
DASH-50 VERSUS DASH-60 DESIGNS**

Pump Model (Port Type)	Dash-50 Design		Dash-60 Design	
	Inlet	Outlet	Inlet	Outlet
SV10/SV15 (Straight Thread)	SAE 16 1-5/16 x 12	SAE 12 1-1/16 x 12	SAE 20 1-5/8 x 12	SAE 12 1-1/16 x 12

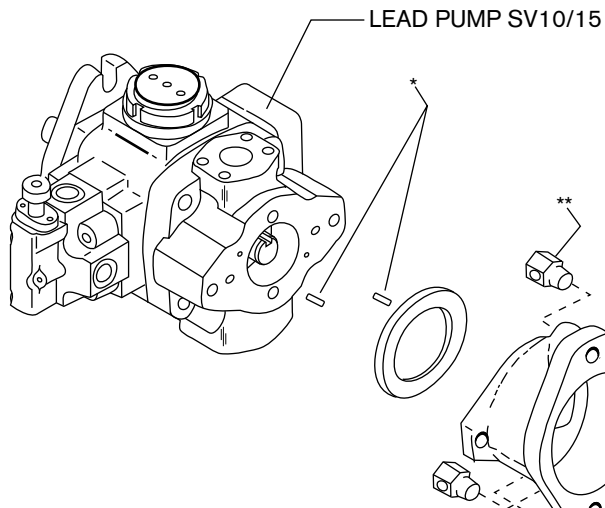

ASSEMBLE WITH DRIVE TANG AS SHOWN

ADAPTOR KITS

Description	Hydraulic Code	List #
SV10/SV10	PSV10/10	956101
SV10/PSQ	PSV10/10	956101
SV10/E055	SV10/E055	956177
SV10/20 H, L	SV10/20 H, L	956178
SV10/80 H, M, L	SV10/80 H, M, L	956179
SV10/BOSCH F	SV10/BOSCH F GEAR	956320

NOTE: Coupling system is a "Wet Design." The lead pump does not have a rear shaft seal. This allows the adaptor to fill with fluid to lubricate and cool the coupling.

** NOTE: When the weight of the trailing pump(s) exceeds 65 lbs., this part must be used.

* NOTE: Roll pins should be pressed into pump prior to assembly.

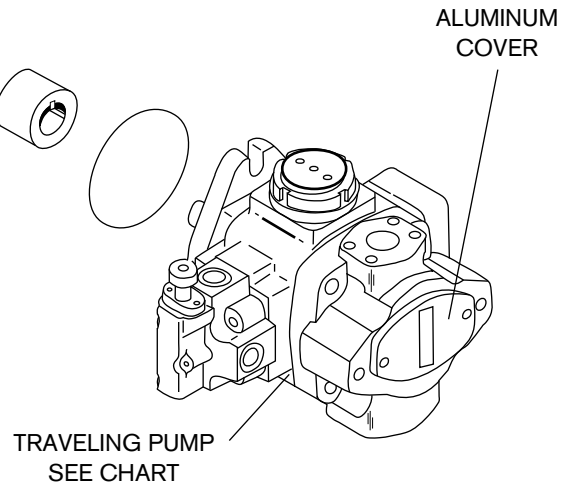

COMPLETE ASSEMBLY
 956302 – SV10 – 2000 PSI
 956304 – SV15 – 1000 PSI

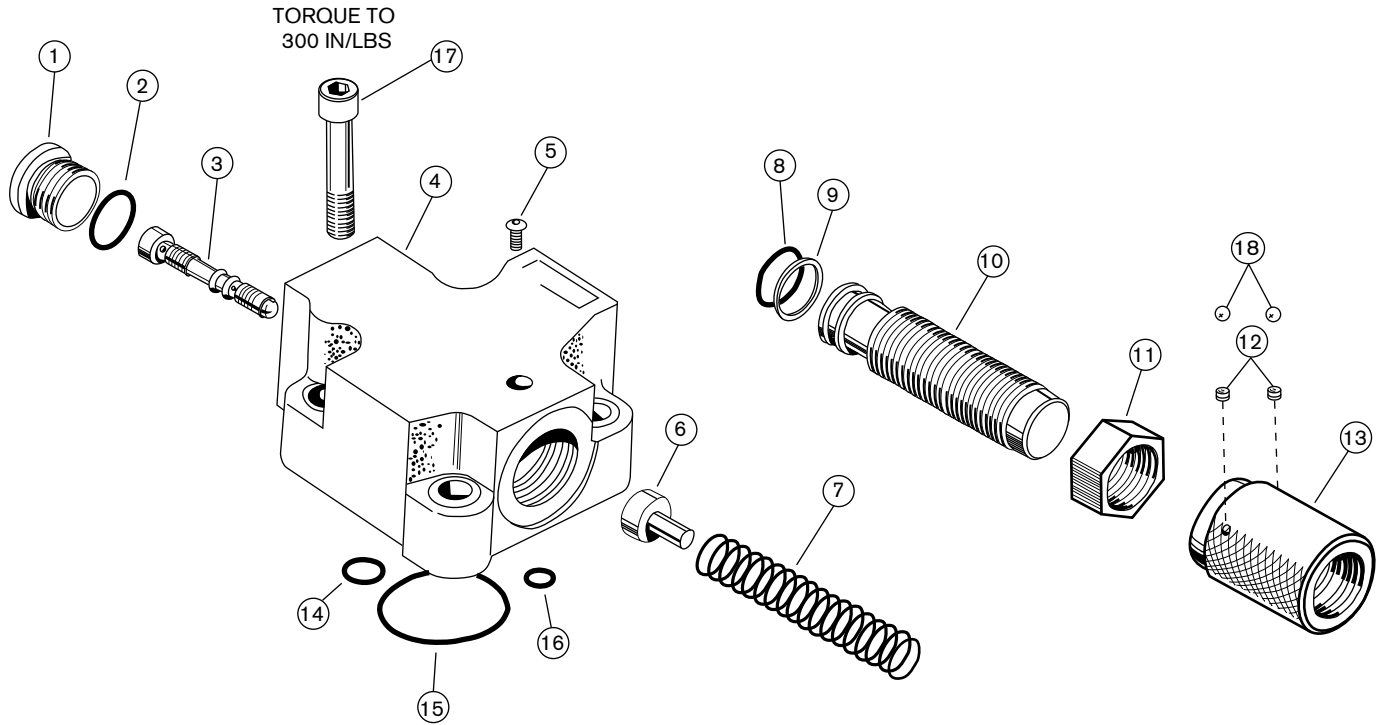

Ref. No.	Part No.	Description	Qty.
1	491832	Plug, SAE #8	1
2	407139	O-Ring, SAE #8 -908	1
3	309291	Spool	1
4	233109	Body	1
5	457564	Screw	1
6	309290	Spring Seat	1
7	457561	Spring	1
8	406554	O-Ring, 5/8 x 3/4 x 1/6 -016	1
9	492369	Back-up Ring	1
10	309289	Internal Adjustment Barrel	1
11	309019	Lock Nut	1
12	457688	Set Screw, 1/4-20 x 1/8	2
13	309292	Pressure Adjustment Knob	1
14	406797	O-Ring, 1-16 x 5/16 x 7/16 -011	1
15	407105	O-Ring, 1-16 x 1-1/2 x 1-5/8 -029	1
16	406565	O-Ring, 1-16 x 7/16 x 9/16 -013	1
*17	400789	Screw, 5/16-18 x 1-1/4	4
18	457689	Plastic Ball, 9/64 Diameter	2

Item 17 is not included in the complete assembly.

STANDARD TWO-STAGE COMPENSATOR—FIRST STAGE

**-56 DESIGN
-66 DESIGN**

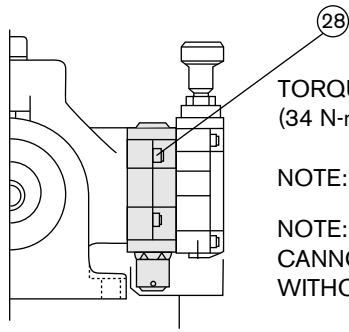

TORQUE TO 300 IN-LBS
(34 N-m)

NOTE: RIGHT HAND ROTATION SHOWN.

NOTE: THE FIRST STAGE
CANNOT BE PURCHASED
WITHOUT THE SECOND STAGE.

STANDARD TWO STAGE
PRESSURE COMPENSATOR
SV10 956131
SV15 956112

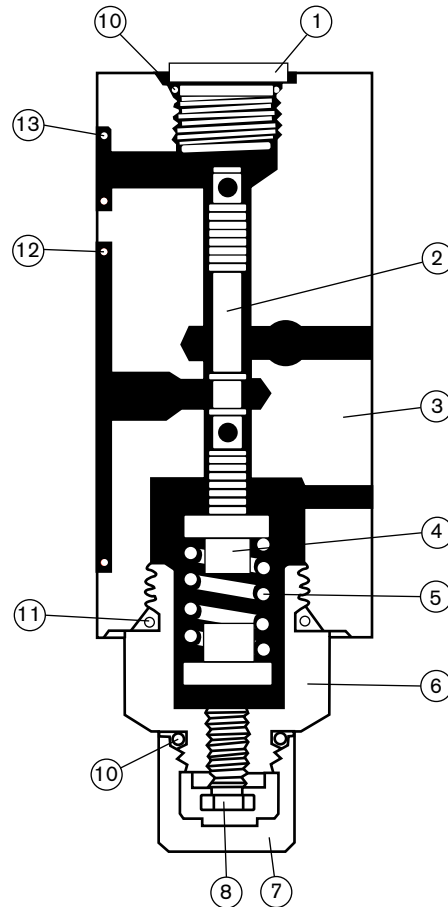

Ref. No.	Part No.	Description	Qty.
1	491832	Plug, SAE #8	1
2	308736	Spool (White)	1
3	223052	Body, 1st Stage (Iron)	1
4	308943	Spring Seat	2
5	491831	Spring	1
6	309052	Adaptor	1
7	308936	Safety Cap	1
8	778459	Adjustment Screw & Locknut	1
*10	407139	O-Ring, #8 SAE (-908)	2
*11	407138	O-Ring, #10 SAE (-910)	1
*12	407105	O-Ring, 1/16 x 1-1/2 x 1-5/8	1
*13	406797	O-Ring, 1/16 x 5/16 x 7/16 (Used with 223052)	1
**14	406565	O-Ring, 1/16 x 7/16 x 9/16	1
***28	400789	Screw, Socket Head, 5/16-18 x 1-1/4	4

* Included in Seal Kit 778358.

** Not shown.

*** On standard Compensated and Load Sensing Compensating Pumps, this screw is used to mount the 1st stage to the pump body. All other optional compensators or controls use 491838 ferry head cap screws.
CAUTION: Do not over torque.

-56 DESIGN
-66 DESIGN

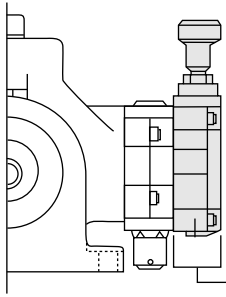

NOTE: RIGHT HAND
ROTATION SHOWN.

SECOND STAGE (ONLY)
PRESSURE COMPENSATOR
SV10 956119
SV15 956120

Ref. No.	Part No.	Description*	Qty.
1	402396	Screw, #10-24 X 1/2	2
2	401714	Roll Pin	1
3	308730	Knob	1
4	490418	Back-up Ring	1
5	406579	O-ring, (-111 Viton 75)	1
6	406618	Plug, #4 SAE with O-Ring (-904)	1
7	406797	O-Ring, 1/16 x 5/16 x 7/16	3
8	400779	Screw, 1/4-20 x 1-1/4	3
9	221777	Retaining Cap	1
10	309028	Adjusting Screw	1
11	401011	Lock Nut	1
12	407846	Spring	1
13	222962	Body	1
14	309057	Poppet	1
15	778462	Seat & O-Ring	1

* Not valid for design series -53/-63.

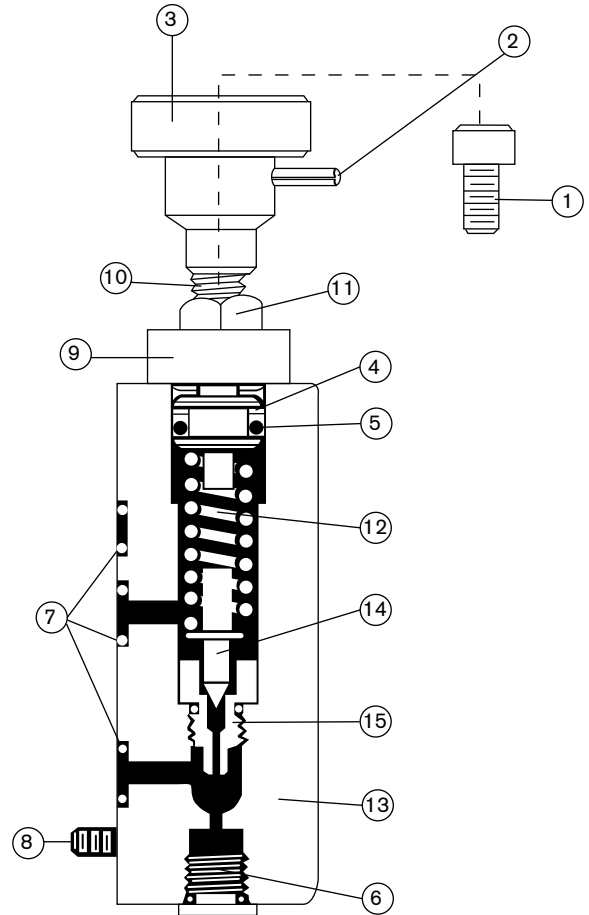

Bosch Automation Technology

NORTH AMERICA

Robert Bosch Corporation
Automation Technology Division
Fluid Power Products
7505 Durand Avenue
Racine, Wisconsin 53406
Phone (262) 554-7100
Fax (262) 554-7117
FAXline (888) 308-3424
www.boschat.com

Robert Bosch Corporation
Automation Technology Division
Factory Automation Products
816 East Third Street
Buchanan, MI 49107
Phone (616) 695-0151
Fax (616) 695-5363
FAXline (888) 308-3424
www.boschat.com

Robert Bosch Corporation
Automation Technology Division
Industrial Electronics Products
40 Darling Drive
Avon, CT 06001-4217
Phone (860) 409-7070
Fax (860) 409-7080
FAXline (888) 308-3424
www.boschat.com

EUROPE

Robert Bosch GmbH
Geschäftsbereich
Automationstechnik
Postfach 30 02 07
D-70442 Stuttgart
Telefax (0711) 811-7712

For more information, you may contact your nearest Bosch distributor:



BOSCH