



BOSCH

Engineering Data

VARIABLE VOLUME

VANE PUMPS

MODEL SV-40

MODEL TV-40

FLANGE MOUNTED

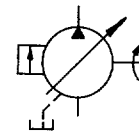
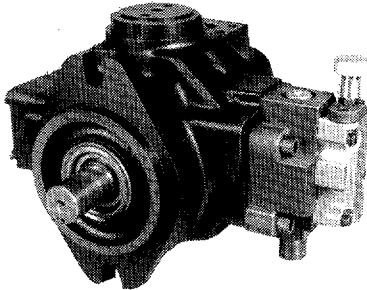

SYMBOL

QUICK REFERENCE CHART

MODEL	GPM @ 100 PSI	MAXIMUM PRESSURE (PSI)	MAXIMUM RPM	PRESSURE COMPENSATING RANGE (PSI)	THEORETICAL DISPLACEMENT IN ³ /REV	INPUT HP @ MAX PSI & 1800 RPM
SV-40	31 @ 1800 RPM	2000	1800	250-2000	4	41
TV-40	23 @ 1200 RPM	1000	1500	250-1000	4.4	16

STANDARD PUMP — The SV pump is a pressure compensated vane pump and is available in four basic displacements; one, two, four, and eight cubic inches. This bulletin covers the model SV-40 (four cubic inch displacement) and a variation of it which is dimensionally the same.

TWINVANE PUMP — The TV-40 (TWINVANE) pump is a standard pump with internal changes which allow it to operate on either high water content fluids (HWCF) or petroleum fluids. It provides an equivalent life on HWCF with only a slight reduction in volumetric and overall efficiency when compared to operation with petroleum oil at the same pressure and rpm.

PUMP MODEL	SERVICE BULLETIN
SV-40	7.50-52 & 62
TV-40	7.52-62
PUMP CONTROLS	7.90-63

FOR REPAIR PARTS, REFER TO THE SERVICE BULLETIN LISTED IN THE TABLE.

SPECIFICATIONS

STANDARD PUMP

PRESSURE RATING —

SV-40 — 2000 psi (140 bar)

PRESSURE COMPENSATING RANGE —

SV-40 — 250-2000 psi (17-138 bar)

FLOW AT 1800 rpm —

SV-40 — 30 gpm (136/min) at 1900 psi

THEORETICAL DISPLACEMENT —

SV-40 — 4 in³/rev (65.6 ml/rev)

MAXIMUM INLET VACUUM AT SEA LEVEL —

6 in. Hg (152 mm Hg)

3 in. Hg (76 mm Hg) with fluids containing water

MAXIMUM CASE PRESSURE — 10 psi (0.7 bar)

Case drain line should be full intended size (not reduced down). Case pressure spikes can be minimized by using as straight and direct a path to tank as possible. Other drain lines should not be connected to the pump drain line. Always terminate the drain line below the fluid level in the reservoir. Failure to do so will result in loss of pump prime approximately 30 minutes after it is shut down and possible introduction of air into the circuit. Case drain line should be routed to the opposite side of baffle in relation to suction line.

CASE DRAIN FLOW — The values listed below are the average flows which occur only when the pump is compensating. When the pump is not compensating, the values are much lower.

300 in³/min (4.9 l/min) at 1000 psi (69 bar)

400 in³/min (6.6 l/min) at 2000 psi (138 bar)

DRIVE SPEED RANGE — 750-1800 rpm (Consult factory Applications Dept. for higher speeds)

MOUNTING — SAE C 2-Bolt Flange, side or rear ported.

ROTATION — Right hand and left hand rotation is available. Rotation is always determined when viewing the shaft end.

SEALS — Buna N seals are compatible with petroleum oil, water glycol, and water-in-oil emulsion. When using phosphate ester, viton seals must be specified. Viton is compatible with all of the fluids mentioned.

FILTRATION — A 10 micrometre return line filter is recommended for increased pump life. If a suction strainer is used, it should not be finer than 100 mesh (149 micrometre) when using petroleum fluids. The higher specific gravity of fire resistant fluids and the higher vapor pressure of the water containing fluids will aggravate the pump inlet conditions. If a suction strainer is used with these fluids, the mesh must be coarser (60 mesh or 238 micrometre) than what is used with petroleum oil or the surface area increased to reduce the pressure drop.

OVERHUNG LOAD — Radial and axial forces on the shaft are not recommended. Pump and prime mover should be mounted with shafts inline (coaxial) and connected with a flexible coupling. Consult factory Applications Dept. for applications with overhung load.

FLUID RECOMMENDATIONS — A premium quality hydraulic oil with zinc complex anti-wear additives is highly recommended. Refer to RACINE publication S-106, "Petroleum Hydraulic Fluids" for a list of fluids which meet or exceed the RACINE lubrication requirements.

Optimum Viscosity at Operating Temperature	200-300 SUS (43-65 cSt)
Minimum Operating Viscosity	150 SUS (32 cSt)
Maximum Operating Viscosity	1000 SUS (215 cSt)
Maximum Start-up Viscosity	4000 SUS (864 cSt)

To compensate for the reduced lubrication values of even the premium quality water containing fluids (glycols and water-in-oil emulsions), it is necessary to limit system pressure and rpm to the values listed in the table below for an equivalent life.

	Water Glycol	Water-in-Oil Emulsion
Maximum Pressure	1000 psi	750 psi
Maximum RPM	1800 rpm	1200 rpm

Refer to RACINE publication S-107, "Fire Resistant Fluids", for further details on fluid selection. Fluid suppliers should be consulted regarding proper fluid maintenance when using fire resistant fluids containing water.

TEMPERATURE — The temperature of the fluid in the reservoir should not exceed 130°F (54°C). The pump will operate with oil at higher temperatures provided the viscosity of the fluid is within the recommended range. Under no circumstances should the oil temperature exceed 160°F (71°C). When using fire resistant fluids containing water, the fluid temperature should not exceed 120°F (49°C) to prevent an excessive rate of water evaporation.

SCREW VOLUME CONTROL — The screw volume control is an adjustable stop which is used to reduce the maximum pump flow and is optional. Turning clockwise will reduce the flow in direct proportion to the displacement of the adjusting screw. During initial start-up, the flow setting should be at least 30% of the maximum pump flow.

SV-40 — 1/4 turn (90°) clockwise will reduce the flow approximately 4 gpm (15.1 l/min) when the pump is driven at 1800 rpm.

When a volume control is used to reduce the maximum flow of the pump, the horsepower required to drive the pump is also reduced. To determine the Input HP, use the following formula:

$$\text{Input HP} = \frac{\text{gpm} \times \text{psi}}{1714} + \text{Deadhead HP at the compensator setting}$$

MOUNTING POSITION — Pump should be mounted with the shaft horizontal. Caution must be exercised to prevent end thrust from being applied to the shaft.

SHAFT ALIGNMENT — Shaft alignment should be within 0.003" total indicator reading. If the shafts are not properly aligned, increased mechanical noise from the unit will result.

START-UP — To insure priming on initial start-up, air in the pump and inlet line must be allowed to escape. If the pump outlet is normally blocked, it must be temporarily vented. This can be accomplished by opening the valve, temporarily cracking a fitting, or installing an air bleed valve (refer to Bulletin J-34).

CONTROL OPTIONS — Many energy saving controls are available in addition to the standard two-stage pressure compensator. Refer to Bulletin A-11 for performance and dimensional data.

COMBINATION MOUNTING — To simplify multi-pump circuits, adaptor kits are available to mount additional pumps in combination on the rear cover of the flange mounted (side ported) pumps. Refer to Bulletin A-14 for horsepower limitations, adaptors available, dimensional data, and How-To-Order.

WEIGHT (Approximate) —
Flange Mounted Pump 105 lbs. (47.2 Kg)
Add for Screw Volume Control 1 lbs. (0.5 Kg)

TWINVANE PUMP

NOTE: All of the specifications for the standard pump also pertain to the TWINVANE pump except those listed below.

PRESSURE RATING —
TV-40 — 1000 psi (69 bar)

PRESSURE COMPENSATING RANGE —
TV-40 — 260-1000 psi (18-69 bar)

FLOW —
23 gpm (100 l/min) at 1200 rpm and 100 psi (7 bar)
28.5 gpm (110 l/min) at 1500 rpm and 100 psi (7 bar)

Because of the low viscosity of HWCF, the internal leakage is greater and will result in a slight reduction in flow in comparison to petroleum oil. Refer to the performance characteristics on page 5.

THEORETICAL DISPLACEMENT —
TV-40 — 4.4 in³/rev (72 ml/rev)

MAXIMUM INLET VACUUM AT SEA LEVEL —
When using high water content fluids, a positive head is beneficial but not necessary. The TV-40 can be used up to 12 inches (30 cm) above the fluid level at altitudes to 2000 feet (610 m) above sea level.

CASE DRAIN FLOW — The value listed below is the average flow which will occur when the pump is compensating at 1000 psi. When the pump is not compensating, the flow is much lower.

2.5 gpm (11.3 l/min) at 1200 rpm (HWCF)

DRIVE SPEED RANGE — 750-1500 rpm

ROTATION — Right hand only. Clockwise when viewing shaft end.

SEALS — Viton seals are standard.

SCREW VOLUME CONTROL — The screw volume control is standard.

FLUID RECOMMENDATIONS — If a high water content fluid is used, please consult the factory Applications Dept. during the fluid selection process for current list of approved fluids. This pump is not compatible with phosphate ester fluids.

PERFORMANCE CHARACTERISTICS

STANDARD PUMP

DATA PLOTTED WITH OIL AT 120°F (49°C)
 VISCOSITY @ 120°F = 140 SUS (29.6 cSt)

SV-40 @ 1200 rpm

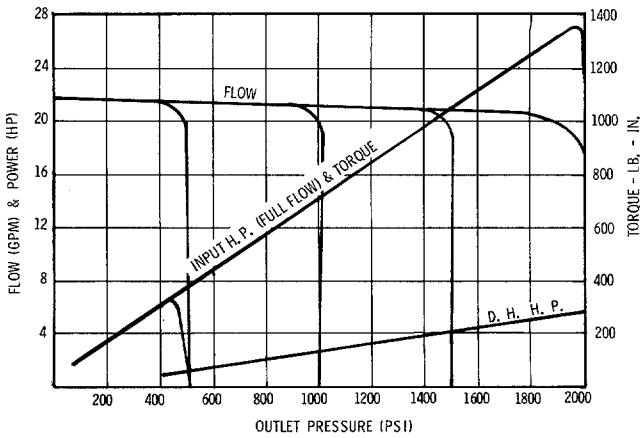

SV-40 @ 1800 rpm

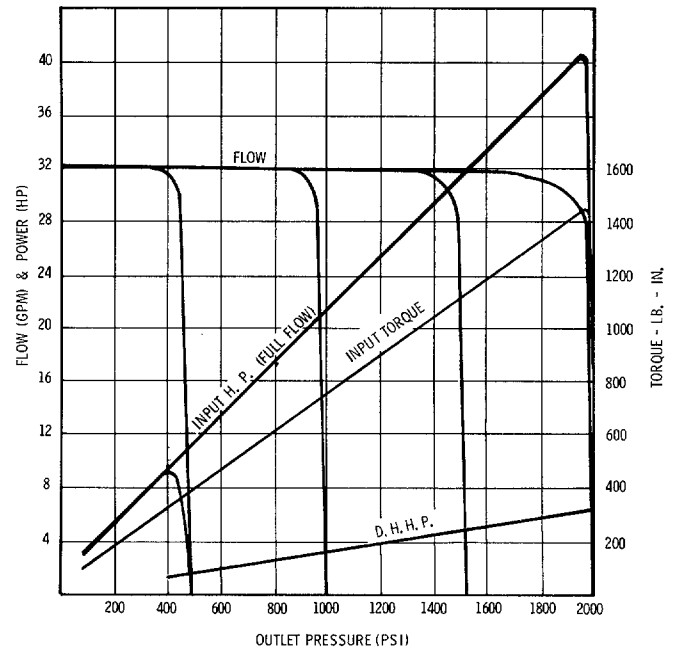

TWINVANE PUMP

— [HWCF @ 110°F (43°C)]
 - - - [140 SUS (29.6 cSt) @ 120°F (49°C)]

TV-40 @ 1200 rpm

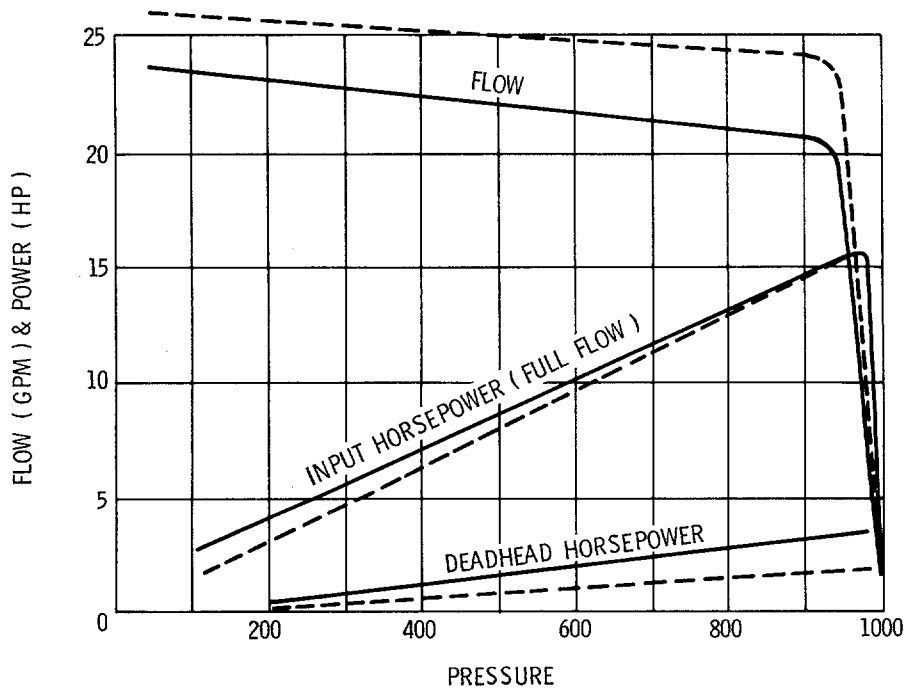

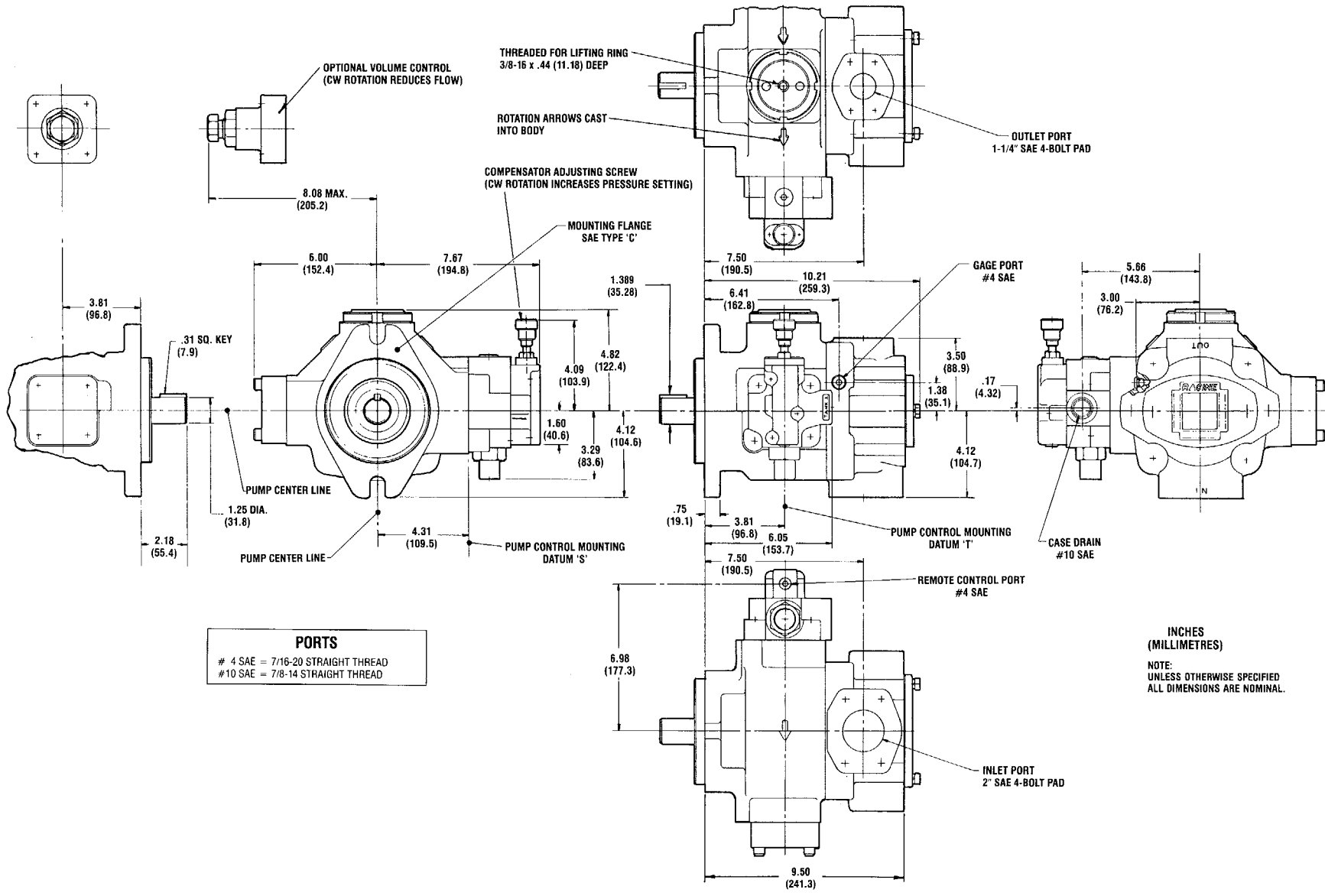

PORTS
 # 4 SAE = 7/16-20 STRAIGHT THREAD
 #10 SAE = 7/8-14 STRAIGHT THREAD

**INCHES
(MILLIMETRES)**
 NOTE:
 UNLESS OTHERWISE SPECIFIED
 ALL DIMENSIONS ARE NOMINAL.

DIMENSIONAL DATA
R.H. FLANGE MTD.
SIDE PORTED

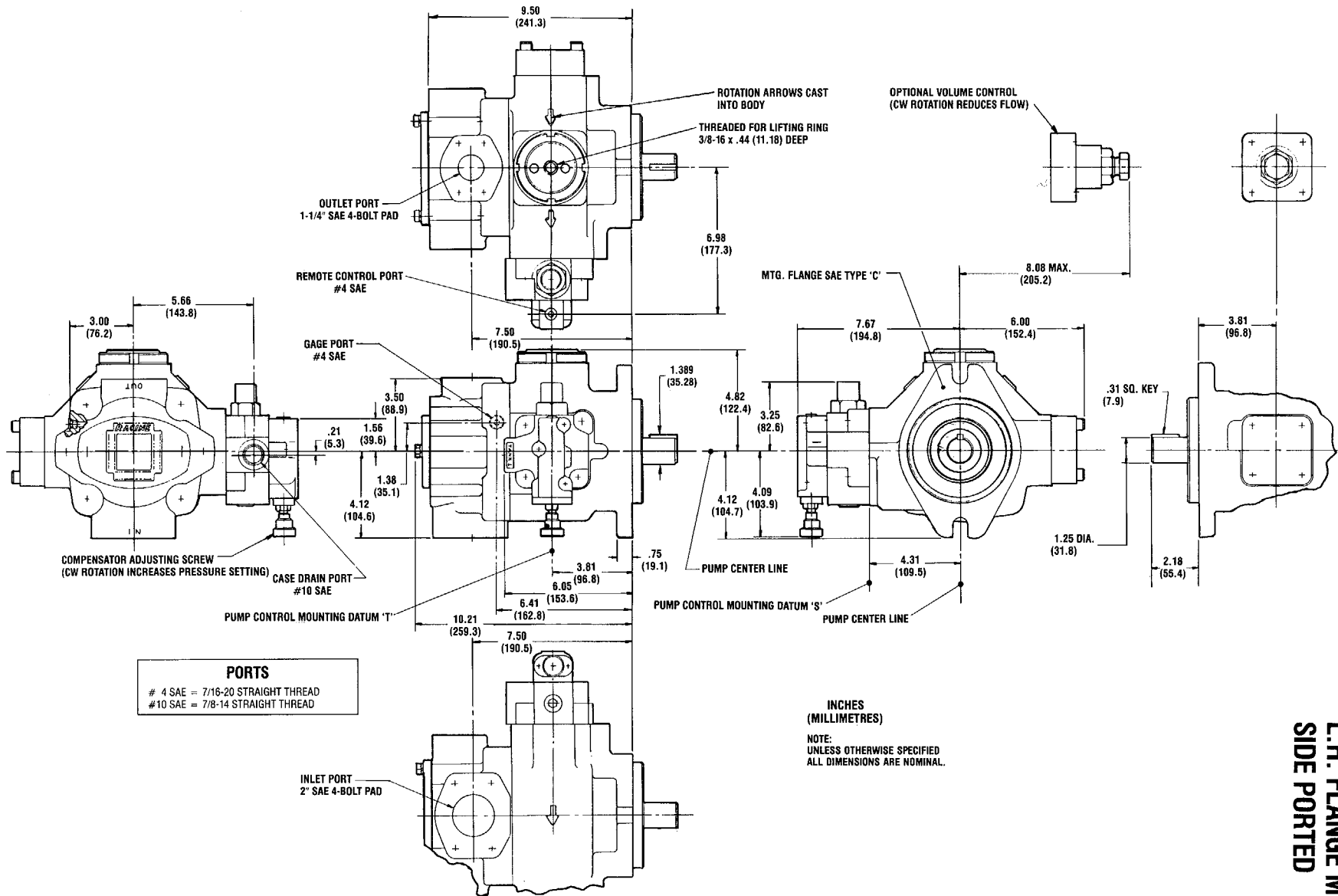

L.H. FLANGE MTD.
 SIDE PORTED

DIMENSIONAL DATA

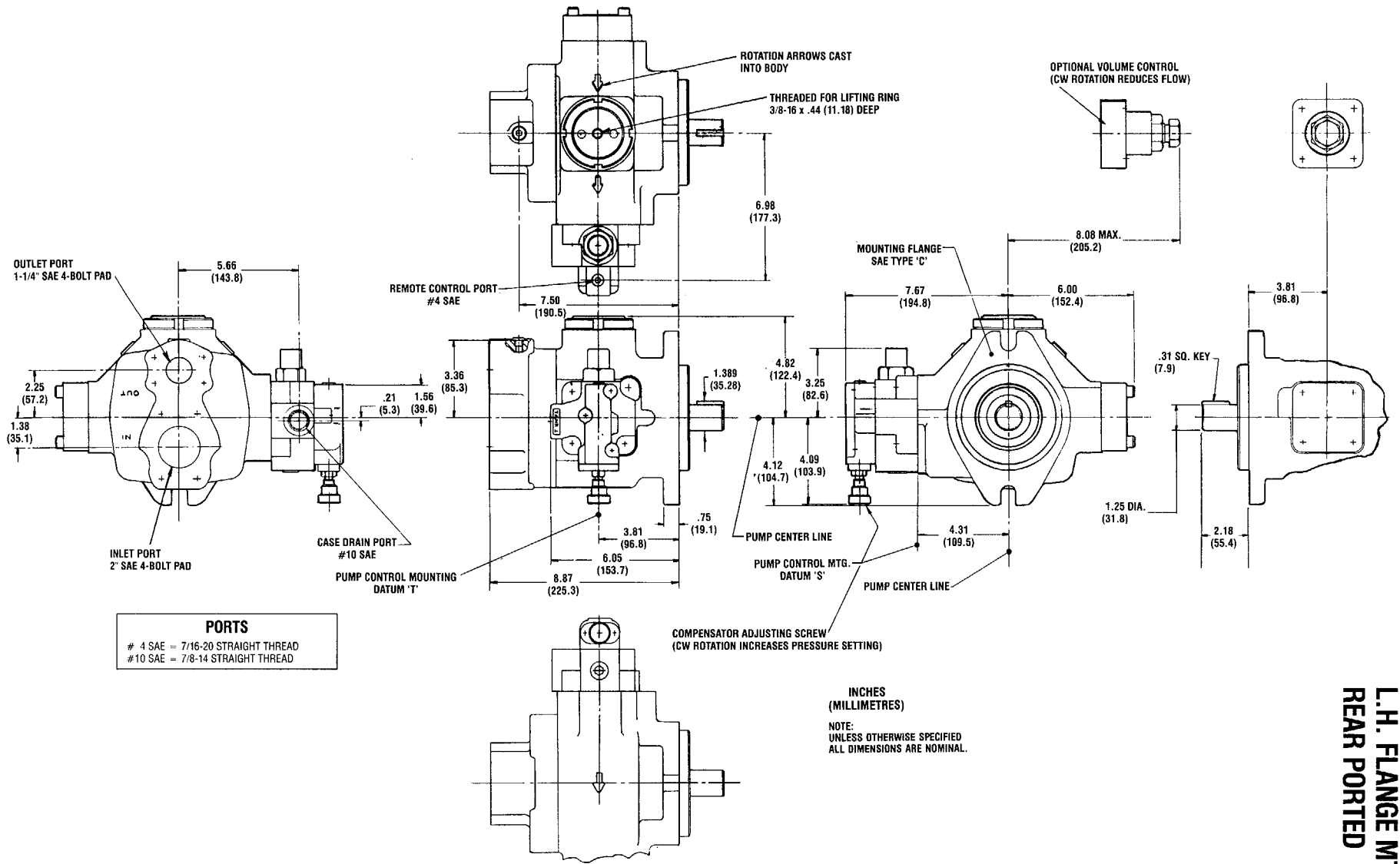

FOOT BRACKET (PSV-40-10B)

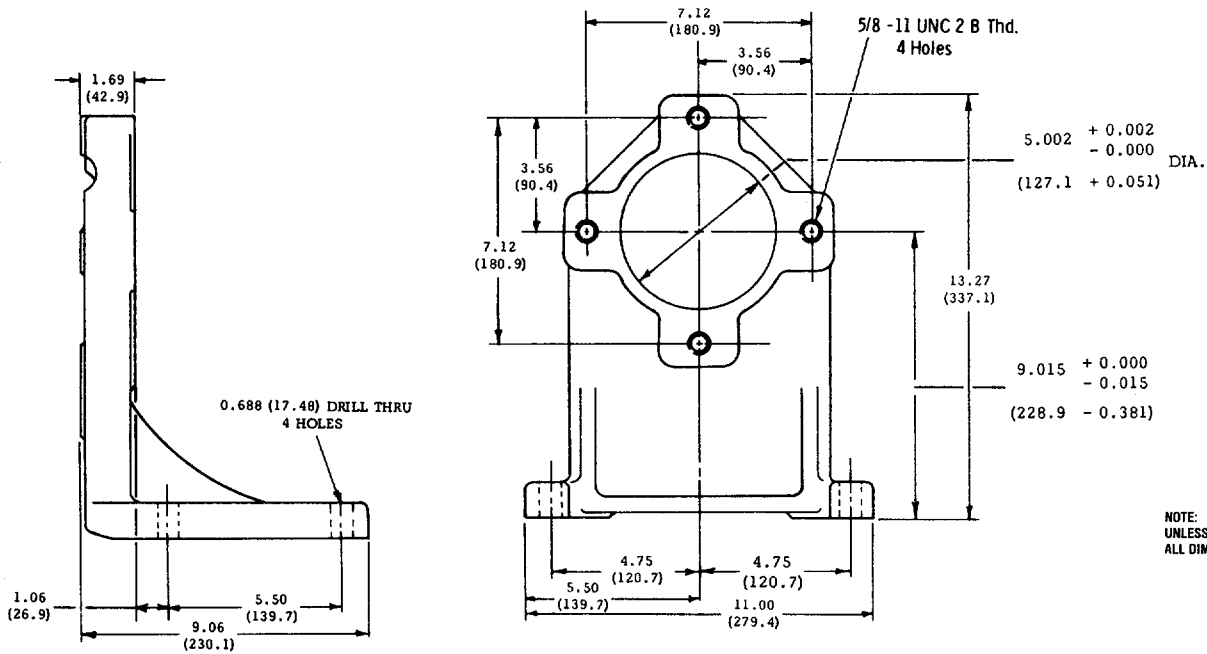

Bolt kit B-113 is included to mount the pump to the foot bracket. Consists of 2 each 5/8-11 x 2-1/4 hex head cap screw and washer.

The center line height of the shaft of an electric motor can be determined by dividing the first two numbers of the motor frame by four.

HOW TO ORDER

FOOT BRACKET

*BRACKET MODEL NUMBER	HEIGHT OF PUMP SHAFT CENTER LINE WHEN MOUNTED TO BRACKET
PSV-40-10B	9.00 (228.6 MM)

*Includes bolt kit B-113 to mount pump to bracket.

Foot bracket and mounting bolts are not included with the pump and must be specified in addition to the pump.

Example: (1) PSV-PNCO-40HRM-62 Pump
(1) PSV-40-10B Foot Bracket

FLANGE KIT

FLANGE KIT NO.	CONSISTING OF
PSV-40-20F-60	1 EA - 2" NPT FLANGE (INLET)
	4 EA - 1/2-13 x 1.75 SOCKET HEAD CAP SCREW
	1 EA - 1/8 x 2-1/4 x 2-1/2 O-RING
	1 EA - 1-1/4 NPT FLANGE (OUTLET)
	4 EA - 7/16-14 x 1-3/4 SOCKET HEAD CAP SCREW
	1 EA - 1/8 x 1-1/2 x 1-3/4 O-RING

Flanges are not included with the pump and must be specified in addition to the pump.

Example: (1) PSV-PNCO-40HRM-62
(1) PSV-40-20F-60 Flange Kit

STANDARD PUMP

PSV-PNCO-40HRM-62

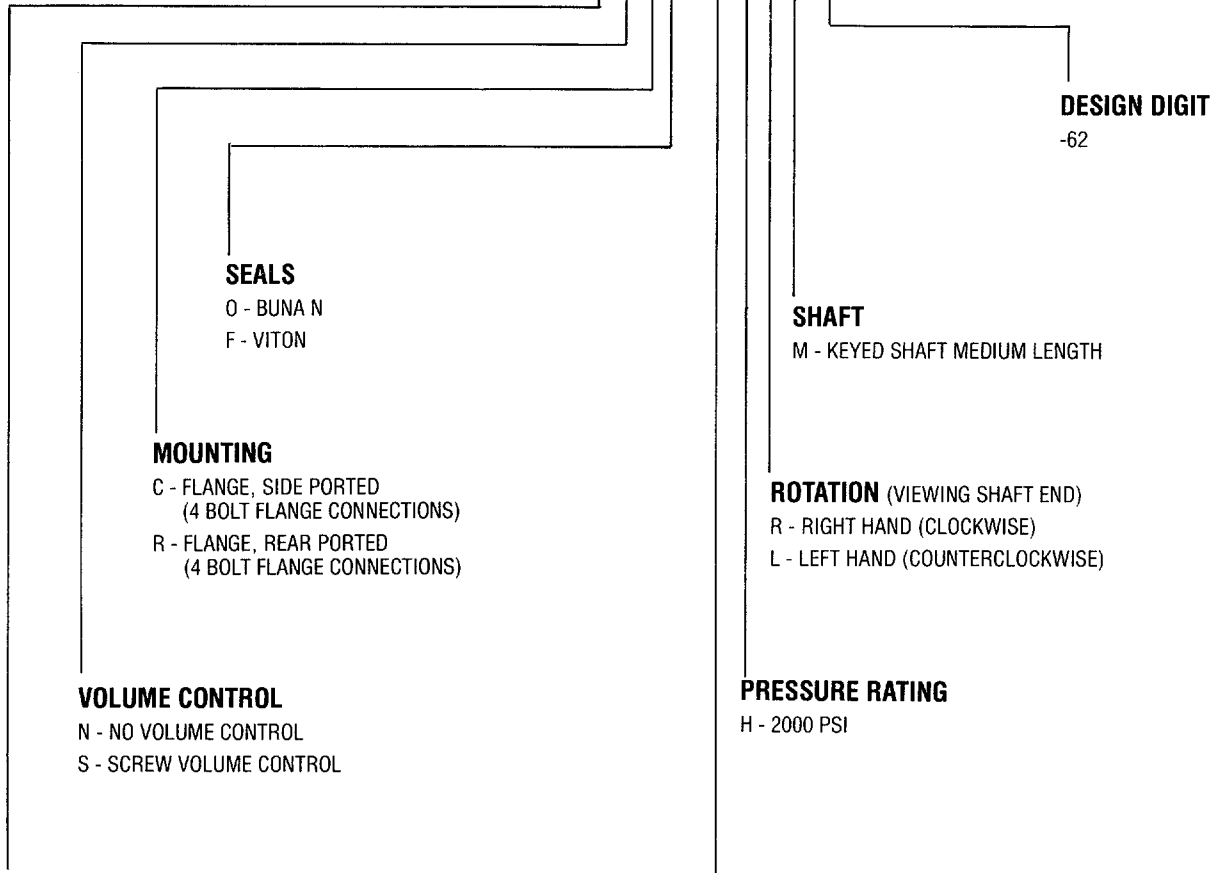

SEALS
 O - BUNA N
 F - VITON

MOUNTING
 C - FLANGE, SIDE PORTED
 (4 BOLT FLANGE CONNECTIONS)
 R - FLANGE, REAR PORTED
 (4 BOLT FLANGE CONNECTIONS)

VOLUME CONTROL
 N - NO VOLUME CONTROL
 S - SCREW VOLUME CONTROL

SHAFT
 M - KEYED SHAFT MEDIUM LENGTH

ROTATION (VIEWING SHAFT END)
 R - RIGHT HAND (CLOCKWISE)
 L - LEFT HAND (COUNTERCLOCKWISE)

PRESSURE RATING
 H - 2000 PSI

DESIGN DIGIT
 -62

CONTROL OPTIONS

- P - STANDARD PRESSURE COMPENSATOR
- *S - SOLENOID TWO-PRESSURE (NORMALLY LOW, ENERGIZE FOR HIGH PRESSURE)
- *H - SOLENOID TWO-PRESSURE (NORMALLY HIGH, ENERGIZE FOR LOW PRESSURE)
- *V - SOLENOID TWO-PRESSURE (NORMALLY VENTED, ENERGIZE FOR HIGH PRESSURE)
- J - HYDRAULIC TWO-PRESSURE (NORMALLY LOW, ENERGIZE FOR HIGH PRESSURE)
- L - LOAD SENSING
- T - TORQUE LIMITING
- K - SINGLE STAGE COMPENSATOR

*Indicate the desired solenoid voltage and frequency at the end of the pump code.

FLOW @ 1800 RPM
 40 - 30 GPM @ 900 PSI

SOLENOID VOLTAGES AVAILABLE
110/115 VAC 50/60 HZ (DUAL FREQUENCY) 220/230 VAC 50/60 HZ (DUAL FREQUENCY) 12 VDC 24 VDC
FOR SOLENOIDS WITH QUICK CONNECT (HIRSCHMANN TYPE) CONSULT FACTORY

To order the lock for the compensator adjusting screw, specify "LOCK" at the end of the code.

TWINVANE PUMP

PTV-PSCH-40ERM-62

DESIGN DIGIT
-62

SEALS
H - HIGH WATER CONTENT FLUID

MOUNTING
C - FLANGE, SIDE PORTED
(4 BOLT FLANGE CONNECTIONS)

VOLUME CONTROL
S - SCREW VOLUME CONTROL

SHAFT
M - KEYED SHAFT MEDIUM LENGTH

ROTATION (VIEWING SHAFT END)
R - RIGHT HAND (CLOCKWISE)

PRESSURE RATING
E - 1000 PSI

FLOW @ 1200 RPM
40 - 22 GPM @ 900 PSI

CONTROL OPTIONS

- P - STANDARD PRESSURE COMPENSATOR
- *S - SOLENOID TWO-PRESSURE (NORMALLY LOW, ENERGIZE FOR HIGH PRESSURE)
- *H - SOLENOID TWO-PRESSURE (NORMALLY HIGH, ENERGIZE FOR LOW PRESSURE)
- *V - SOLENOID TWO-PRESSURE (NORMALLY VENTED, ENERGIZE FOR HIGH PRESSURE)
- J - HYDRAULIC TWO-PRESSURE (NORMALLY LOW, ENERGIZE FOR HIGH PRESSURE)
- L - LOAD SENSING
- T - TORQUE LIMITING

*Indicate the desired solenoid voltage and frequency at the end of the pump code.

SOLENOID VOLTAGES AVAILABLE
110/115 VAC 50/60 HZ (DUAL FREQUENCY)
220/230 VAC 50/60 HZ (DUAL FREQUENCY)
12 VDC
24 VDC
FOR SOLENOIDS WITH QUICK CONNECT (HIRSCHMANN TYPE) CONSULT FACTORY

To order the lock for the compensator adjusting screw, specify "LOCK" at the end of the code.

9 535 233 090
HPUS AKY 003/3 US (7.94)

ROBERT BOSCH FLUID POWER CORPORATION
P.O. BOX 2025
RACINE, WISCONSIN 53401-2025 U.S.A.
Phone (414)554-7100, Fax (414)554-7117



BOSCH

PRINTED IN U.S.A.