

NG 6

1

Proportional-Druckvorsteuerventile

Proportional pilot pressure valves

Valves de pression pilotes proportionnels

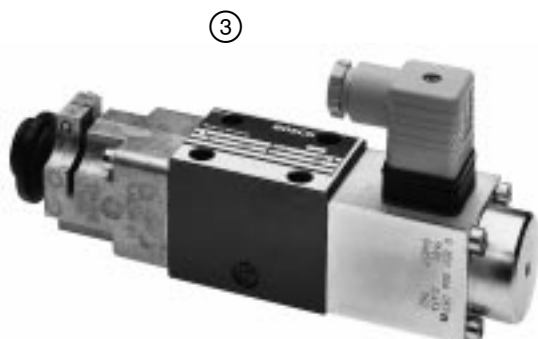
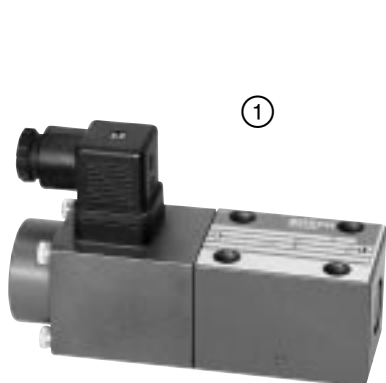

▶ ① **ohne** Lageregelung
Version: Standard 0,8 A / 2,5 A

▶▶ ② **mit** Lageregelung
Version: Standard LVDT – AC

▶▶▶ ③ **mit** Lageregelung
Version: Linear LVDT – AC

▶▶▶▶ ④ **mit** Lageregelung und eingebauter Elektronik – OBE

▶▶▶▶ ① **without** position control
Version: Standard 0.8 A / 2.5 A

▶▶▶▶▶ ② **with** position control
Version: Standard LVDT – AC

▶▶▶▶▶▶ ③ **with** position control
Version: Linear LVDT – AC

▶▶▶▶▶▶▶ ④ **with** position control and on-board electronics – OBE

▶▶▶▶▶▶▶▶ ① **sans** régulation de position
Version: Standard 0,8 A / 2,5 A

▶▶▶▶▶▶▶▶▶ ② **avec** régulation de position
Version: Standard LVDT – AC

▶▶▶▶▶▶▶▶▶▶ ③ **avec** régulation de position
Version: Linéaire LVDT – AC

▶▶▶▶▶▶▶▶▶▶▶ ④ **avec** régulation de position et amplificateur intégré – OBE

Bauart: Sitzventil

Hinweis: Technische Angaben und Kennlinien bezogen auf $Q = 1 \text{ l/min.}$

Construction: Poppet valve





Note: Technical data and performance curves based on $Q = 1 \text{ l/min.}$



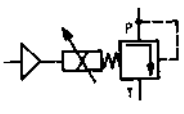
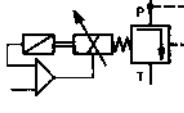
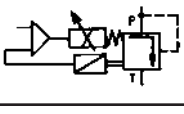
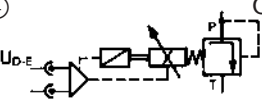

Construction: Valve à clapet

Remarque: Les indications techniques et les courbes caractéristiques se rapportent à $Q = 1 \text{ l/min.}$

NG 6

Bestellübersicht Ordering range Gamme de commande

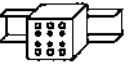
Sinnbild Symbol Symbole	 A/VA max	Q _{nom.} [l/min]	P _{max.} [bar]		Seite Page Page	Ⓜ
① 	0,8/25 (R _L = 20 Ω)	1	50	1-P	10	0 811 402 036
			80	4-P		0 811 402 018
			180	1-M		0 811 402 017
			250	1-K		0 811 402 019
			315			0 811 402 016
	2,5/30 (R _L = 3 Ω)	1	50	2-P		0 811 402 034
			80	3-P		0 811 402 030
			180	2-M		0 811 402 031
			250	2-K		0 811 402 035
			315			0 811 402 032
② 	3,7/60	1	25	3-K	15	0 811 402 013
			80	4-K		0 811 402 007
			180	5-K		0 811 402 003
			250			0 811 402 001
			315			0 811 402 004
③ 	2,7/35	1	80	6-K	20	0 811 402 023
			180	7-K		0 811 402 022
			250	8-K		0 811 402 021
			315			0 811 402 020
④ 	24 V= 40 VA max	1	80		25	0 811 402 072
			180			0 811 402 071
			250			0 811 402 073
			315			0 811 402 070

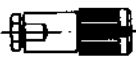
Verstärkertechnik	Amplifier type		Type d'amplificateurs	Seite Page Page	Ⓜ
Sinnbild Symbol Symbole	mit Rampe ● with ramp avec rampe	Alphanumerik Alpha numeric Code alphanumérique			
P 	●	AS 0.8 – V	1-P	246	0 811 405 144
	●	AS 2.5 – V	2-P		0 811 405 143
	●	AS 2.5 – mA	3-P		0 811 405 145
	●	AS 0.8 – mA	4-P		0 811 405 162
M 	●	1 M 0.8 – RGC1	1-M	253	0 811 405 126
	●	1 M 2.5 – RGC1	2-M		0 811 405 127
K 	●	1 M 45 – 0.8 A	1-K	266	0 811 405 081
	●	1 M 45 – 2.5 A	2-K		0 811 405 079
		PV 60	3-K		0 811 405 097
	●	PV 60 – RGC1	4-K		0 811 405 102
	●	PV 60 – RGC3	5-K		B 830 303 391
		PDL 1 –	6-K		0 811 405 095
	●	PDL 1 – RGC1	7-K		0 811 405 100
	●	PDL 1 – RGC3	8-K		B 830 303 387
	Stecker 7-polig für OBE Plug 7-pole for OBE Connecteur 7 pôles pour OBE			241	

NG 6

Druckbegrenzungsventile Pressure relief valves Limiteurs de pression



Funktion
Function
Fonction

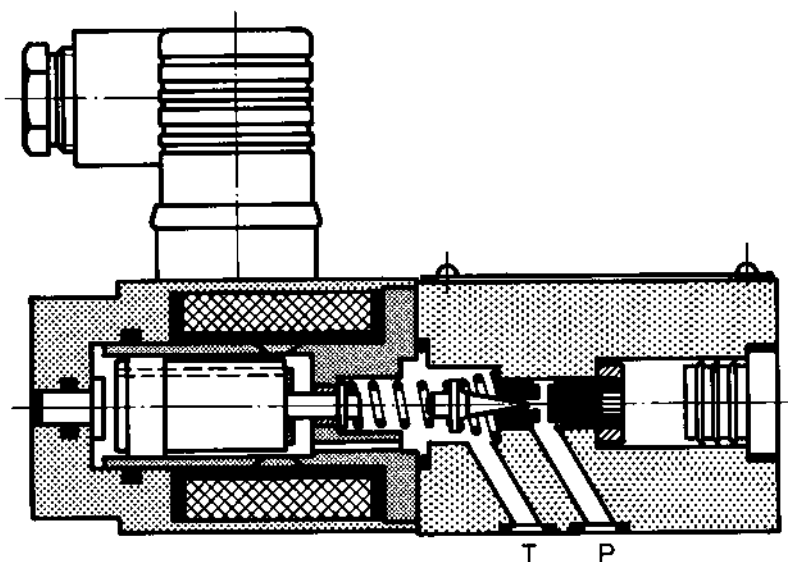

▶ Vorsteuerstufe ($Q_{nom.} = 1 \text{ l/min}$)
ohne Lageregelung

▶▶ Pilot stage ($Q_{nom.} = 1 \text{ l/min}$)
without position control

▶▶▶ Étage pilote ($Q_{nom.} = 1 \text{ l/min}$)
sans régulation de position

Sinnbild Symbol Symbole	A/VA max	$Q_{nom.}$ [l/min]	$p_{max.}$ [bar]		[kg]	⊕
	0,8/25 ($R_L = 20 \Omega$)	1	50	1-P	1,9	0 811 402 036
			80	4-P		0 811 402 018
			180	1-M		0 811 402 017
			250	1-K		0 811 402 019
			315			0 811 402 016
	2,5/30 ($R_L = 3 \Omega$)	1	50	2-P	1,9	0 811 402 034
			80	3-P		0 811 402 030
			180	2-M		0 811 402 031
			250	2-K		0 811 402 035
			315			0 811 402 032
(4 x) M 5 x 30 DIN 912-10.9						2 910 151 166
P	246	 Seite Page	AS 0.8 - V	1-P	0,15	0 811 405 144
	AS 2.5 - V		2-P	0 811 405 143		
	AS 2.5 - mA		3-P	0 811 405 145		
	AS 0.8 - mA		4 P	0 811 405 162		
	M	253	1 M 0.8 - RGC1	1-M	0,25	0 811 405 126
	1 M 2.5 - RGC1	2-M	0 811 405 127			
	K	266		1 M 45 - 0.8 A	1-K	0,20
	1 M 45 - 2.5 A	2-K		0 811 405 079		

Kenngrößen

Allgemein					
Bauart	Sitzventil				
Betätigung	Proportionalmagnet ohne Lageregelung				
Anschlussart	Plattenanschluss, Lochbild NG 6 (ISO 4401)				
Einbaulage	beliebig				
Umgebungstemperatur	-20 ... +50 °C				
Hydraulisch					
Druckmittel	Hydrauliköl nach DIN 51 524 ... 535, andere Medien nach Rückfrage				
Viskosität, empfohlen	20 ... 100 mm ² /s				
	max. zulässig 10 ... 800 mm ² /s				
Druckmitteltemperatur	-20 ... +80 °C				
Filterung	Zulässige Verschmutzungsstufe des Druckmittels nach NAS 1638				Zu erreichen mit Filter
	8				$\beta_x = 75$
	9				X = 10
	10				20
Entsprechend Betriebssicherheit und Lebensdauer					25
Durchflussrichtung	siehe Sinnbild				
Nennndruck (bei Q = 1 l/min)	50	80	180	250	315 bar
Minimaldruck (bei Q = 1 l/min)	2	3	4	5	8 bar
Hinweis: Bei Q _{max} = 1,5 l/min erhöhen sich die angegebenen Drücke					
Max. Betriebsdruck (statisch)	Anschluss P: 315 bar Anschluss T: 250 bar				
Elektrisch					
Relative Einschaltzeit	100% ED				
Schutzart	IP 65 nach DIN 40 050 und IEC 14 434/5				
Anschluss Magnet	Gerätesteckdose DIN 43 650/ISO 4400				
Magnetstrom	0,8 A				2,5 A
Spulenwiderstand R ₂₀	20 Ω				3 Ω
Max. Leistungsaufnahme bei 100% Last und Betriebstemperatur	25 VA max				30 VA max
Statisch/Dynamisch					
Hysterese	≦ 4%				
Umkehrspanne	≦ 3%				
Exemplarstreuung für p _{max}	≦ 10%				
Stellzeit 100% Signalsprung	EIN: < 60 ms				
	AUS: < 70 ms				

Alle Kenngrößen in Verbindung mit Proportionalverstärker: 1 M 45 – 0.8 A (max. 0,8 A)
1 M 45 – 2.5 A (max. 2,5 A)



Characteristics

General

Construction	Poppet valve
Actuation	Proportional solenoid without position control
Connection type	Subplate, mounting hole configuration NG 6 (ISO 4401)
Mounting position	optional
Ambient temperature range	-20 ... +50 °C

Hydraulic

Pressure medium	Hydraulic oil as per DIN 51 524 ... 535, other fluids after prior consultation				
Viscosity, recommended max. permitted	20 ... 100 mm ² /s				
	10 ... 800 mm ² /s				
Pressure medium temperature	-20 ... +80 °C				
Filtration	Permissible contamination class of pressure medium as per NAS 1638			Achieved using filter $\beta_x = 75$	
In line with operational reliability and service life	8			X = 10	
	9			20	
	10			25	
Flow direction	cf. symbol				
Nominal pressure (at Q = 1 l/min)	50	80	180	250	315 bar
Minimum pressure (at Q = 1 l/min)	2	3	4	5	8 bar
	Note: At $Q_{max} = 1.5$ l/min, the pressures stated here increase				
Max. working pressure (static)	Port P: 315 bar Port T: 250 bar				

Electrical

Cyclic duration factor	100%				
Degree of protection	IP 65 as per DIN 40 050 and IEC 14 434/5				
Solenoid connector	Connector DIN 43 650/ISO 4400				
Solenoid current	0.8 A			2.5 A	
Coil resistance R_{20}	20 Ω			3 Ω	
Max. Power consumption at 100% load and operational temperature	25 VA max			30 VA max	

Static/Dynamic

Hysteresis	$\leq 4\%$				
Range of inversion	$\leq 3\%$				
Manufacturing tolerance p_{max}	$\leq 10\%$				
Response time 100% signal change	ON: < 60 ms OFF: < 70 ms				

All characteristic values in connection with proportional amplifier: 1 M 45 – 0.8 A (max. 0.8 A)
1 M 45 – 2.5 A (max. 2.5 A)



Caractéristiques

Générales

Construction	Valve à clapet
Commande	Aimant à action proportionnelle sans régulation de position
Raccordement	Embase selon plan de pose NG 6 (ISO 4401)
Position de montage	indifférente
Température ambiante	-20 ... +50 °C

Hydrauliques

Fluide	Fluide hydraulique selon norme DIN 51 524 ... 535, autre fluide sur demande				
Viscosité, conseillée max. admissible	20 ... 100 mm ² /s				
	10 ... 800 mm ² /s				
Température du fluide	-20 ... +80 °C				
Filtration	Classe de pollution admissible du fluide selon NAS 1638			Avec un filtre	
	8			β _x = 75	
	9			X = 10	
	10			20	
Selon sécurité de fonctionnement et durée de vie				25	
Sens d'écoulement	voir symbole				
Pression nominale (pour Q = 1 l/min)	50	80	180	250	315 bar
Pression minimale (pour Q = 1 l/min)	2	3	4	5	8 bar
	Remarque: Les pressions indiquées augmentent pour Q _{max.} = 1,5 l/min				
Pression de service max. (statique)	Orifice P: 315 bar Orifice T: 250 bar				

Electriques

Facteur de marche réelle	FM 100%				
Degré de protection	IP 65 selon norme DIN 40 050 et IEC 14 434/5				
Branchement électro-aimant	par prise selon norme DIN 43 650/ISO 4400				
Courant d'alimentation de l'électro-aimant	0,8 A			2,5 A	
Résistance de la bobine R ₂₀	20 Ω			3 Ω	
Consommation max. pour charge 100% et température de service	25 VA max			30 VA max	

Statiques/Dynamiques

Hystérésis	≅ 4%				
Seuil d'inversion	≅ 3%				
Dispersion pour p _{max.}	≅ 10%				
Temps de réponse pour une course de 100%	Marche: < 60 ms				
	Arrêt: < 70 ms				

Toute caractéristique en liaison avec l'amplificateur électronique proportionnel: 1 M 45 – 0,8 A (max. 0,8 A)

1 M 45 – 2,5 A (max. 2,5 A)

1

Kennlinie
Performance curve
Courbe caractéristique
 $v = 35 \text{ mm}^2/\text{s}$

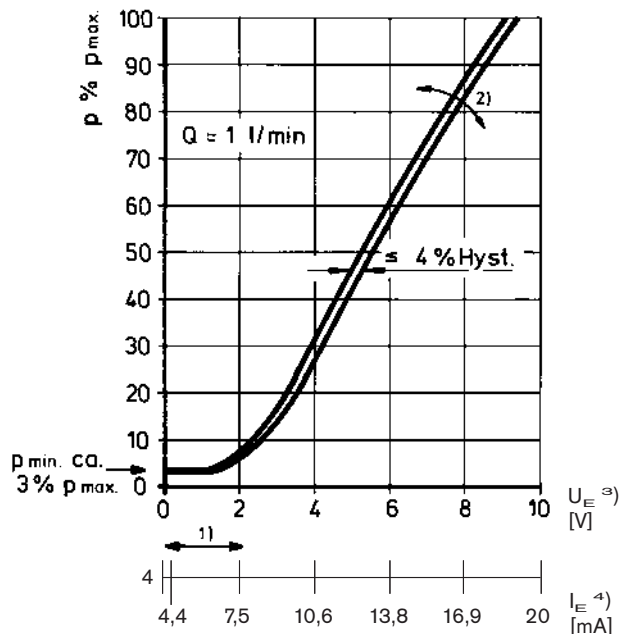

Ventilverstärker

- 1) Nullpunkt-Justierung
- 2) Empfindlichkeits-Justierung
- 3) Version: $U_E = 0 \dots +10 \text{ V}$
- 4) Version: $I_E = 4 \dots 20 \text{ mA}$

Valve amplifier

- 1) Zero adjustment
- 2) Gain adjustment
- 3) Version: $U_E = 0 \dots +10 \text{ V}$
- 4) Version: $I_E = 4 \dots 20 \text{ mA}$

Amplificateur de valve

- 1) Tarage du zéro
- 2) Tarage du gain
- 3) Version: $U_E = 0 \dots +10 \text{ V}$
- 4) Version: $I_E = 4 \dots 20 \text{ mA}$

Abmessungen
Dimensions
Cotes d'encombrement

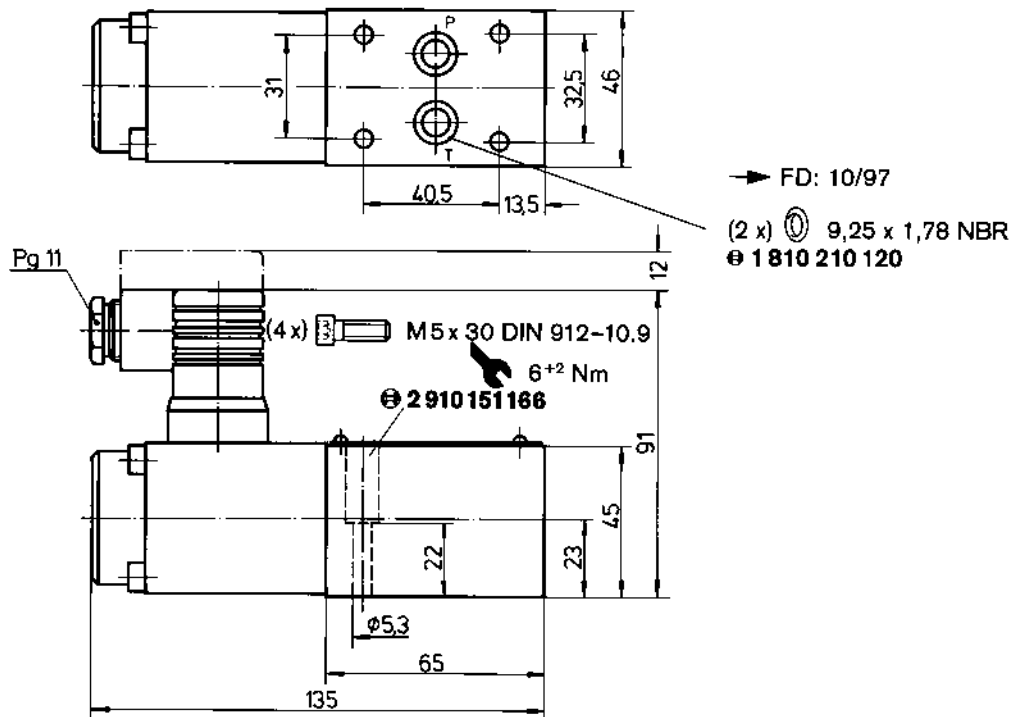

Abmessungen des Anschlusslochbildes NG 6 ISO 4401 siehe Seite 212

Dimensions of mounting hole configuration NG 6 ISO 4401 see page 212

Cotes du plan de pose NG 6 ISO 4401 voir page 212

NG 6

Druckbegrenzungsventile Pressure relief valves Limiteurs de pression



1

Funktion
Function
Fonction

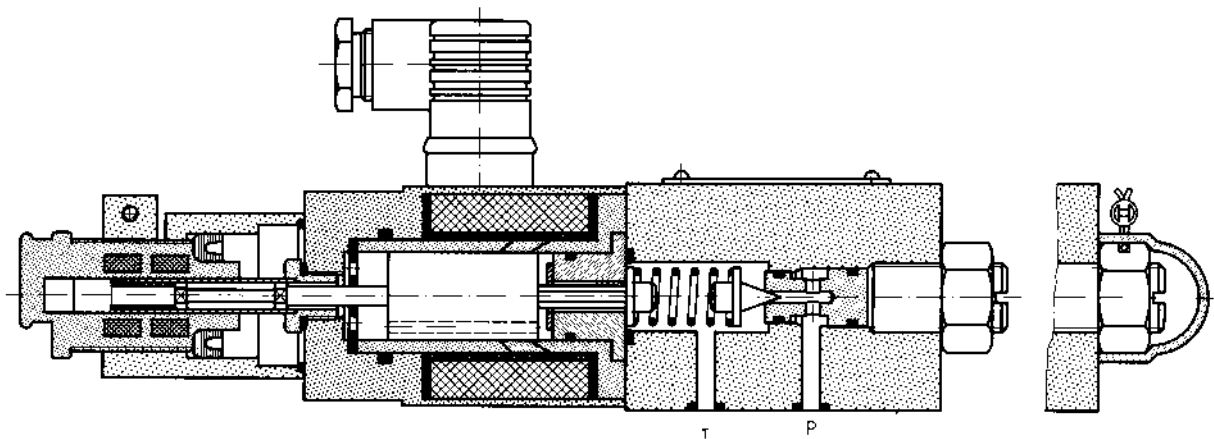

▶ Vorsteuerstufe ($Q_{nom.} = 1$ l/min)
mit Lageregelung

▶▶ Pilot stage ($Q_{nom.} = 1$ l/min)
with position control

▶▶▶ Étage pilote ($Q_{nom.} = 1$ l/min)
avec régulation de position

Sinnbild Symbol Symbole	A/VA max	$Q_{nom.}$ [l/min]	$P_{nom.}$ [bar]		[kg]	⊕
②	3,7/60	1	1,5 ... 28	3-K	4,5	0 811 402 013
			3 ... 80	4-K		0 811 402 007 *
			4 ... 180	5-K		0 811 402 003
			5 ... 250			0 811 402 001 *
			6 ... 315			0 811 402 004
(4 x) M 5 x 50 DIN 912-10.9						
K	 Seite Page 266	PV 60		3-K	0,2	0 811 405 097
		PV 60 – RGC1		4-K	0,2	0 811 405 102
		PV 60 – RGC3		5-K	0,3	B 830 303 391

* mit Plombierung
with seal
avec plombage

Kenngößen

Allgemein

Bauart	Sitzventil
Betätigung	Proportionalmagnet mit Lageregelung
Anschlussart	Plattenanschluss, Lochbild NG 6 (ISO 4401)
Einbaulage	beliebig
Umgebungstemperatur	-20 ... +50 °C

Hydraulisch

Druckmittel	Hydrauliköl nach DIN 51 524 ... 535, andere Medien nach Rückfrage				
Viskosität, empfohlen max. zulässig	20 ... 100 mm ² /s				
	10 ... 800 mm ² /s				
Druckmitteltemperatur	-20 ... +80 °C				
Filterung	Zulässige Verschmutzungsstufe				Zu erreichen mit Filter
	des Druckmittels nach NAS 1638				$\beta_x = 75$
	8				X = 10
	9				20
Entsprechend Betriebssicherheit und Lebensdauer	10				25
	siehe Sinnbild				
Nenndruck (bei Q = 1 l/min)	28	80	180	250	315 bar
Minimaldruck (bei Q = 1 l/min)	1,5	3	4	5	6 bar
	Hinweis: Bei Q _{max.} = 3 l/min erhöhen sich die angegebenen Drücke				
Max. Betriebsdruck	Anschluss P: 315 bar Anschluss T: ≤ 2 bar				

Elektrisch

Relative Einschaltdauer	100% ED
Schutzart	IP 65 nach DIN 40 050 und IEC 14 434/5
Anschluss Magnet	Gerätesteckdose DIN 43 650/ISO 4400
Anschluss Wegaufnehmer	Spezialsteckdose
Magnetstrom	max. 3,7 A
Spulenwiderstand R ₂₀	2,5 Ω
Max. Leistungsaufnahme bei 100% Last und Betriebstemperatur	60 VA max

Statisch/Dynamisch

Hysterese	≤ 0,3%
Umkehrspanne	≤ 0,2%
Exemplarstreuung für p _{max.}	≈ 6%
Stellzeit 100% Signalsprung	45 ms
	10% Signalsprung

Alle Kenngößen in Verbindung mit Proportionalverstärker: PV 60



Characteristics

General

Construction	Poppet valve
Actuation	Proportional solenoid with position control
Connection type	Subplate, mounting hole configuration NG 6 (ISO 4401)
Mounting position	optional
Ambient temperature range	-20 ... +50 °C

Hydraulic

Pressure medium	Hydraulic oil as per DIN 51 524 ... 535, other fluids after prior consultation				
Viscosity, recommended	20 ... 100 mm ² /s				
	max. permitted 10 ... 800 mm ² /s				
Pressure medium temperature	-20 ... +80 °C				
Filtration	Permissible contamination class of pressure medium as per NAS 1638			Achieved using filter $\beta_x = 75$	
In line with operational reliability and service life	8			X = 10	
	9			20	
	10			25	
Flow direction	cf. symbol				
Nominal pressure (at Q = 1 l/min)	28	80	180	250	315 bar
Minimum pressure (at Q = 1 l/min)	1.5	3	4	5	6 bar
	Note: At Q _{max.} = 3 l/min, the pressure stated here increase				
Max. working pressure	Port P: 315 bar Port T: ≤ 2 bar				

Electrical

Cyclic duration factor	100%
Degree of protection	IP 65 as per DIN 40 050 and IEC 14 434/5
Solenoid connector	Connector DIN 43 650/ISO 4400
Position transducer connector	Special connector
Solenoid current	max. 3.7 A
Coil resistance R ₂₀	2.5 Ω
Max. power consumption at 100% load and operational temperature	60 VA max

Static/Dynamic

Hysteresis	≤ 0.3%
Range of inversion	≤ 0.2%
Manufacturing tolerance p _{max.}	≈ 6%
Response time 100% signal change	45 ms
	10% signal change

All characteristic values in connection with proportional amplifier: PV 60



Caractéristiques

Générales

Construction	Valve à clapet
Commande	Aimant à action proportionnelle avec régulation de position
Raccordement	Embase selon plan de pose NG 6 (ISO 4401)
Position de montage	indifférente
Température ambiante	-20 ... +50 °C

Hydrauliques

Fluide	Fluide hydraulique selon norme DIN 51 524 ... 535, autre fluide sur demande				
Viscosité, conseillée max. admissible	20 ... 100 mm ² /s				
	10 ... 800 mm ² /s				
Température du fluide	-20 ... +80 °C				
Filtration Selon sécurité de fonctionnement et durée de vie	Classe de pollution admissible du fluide selon NAS 1638		Avec un filtre $\beta_x = 75$		
	8		X = 10		
	9		20		
	10		25		
Sens d'écoulement	voir symbole				
Pression nominale (pour Q = 1 l/min)	28	80	180	250	315 bar
Pression minimale (pour Q = 1 l/min)	1,5	3	4	5	6 bar
	Remarque: Les pressions indiquées augmentent pour $Q_{max.} = 3$ l/min				
Pression de service max.	Orifice P: 315 bar Orifice T: ≤ 2 bar				

Electriques

Facteur de marche réelle	FM 100%
Degré de protection	IP 65 selon norme DIN 40 050 et IEC 14 434/5
Branchement électro-aimant	par prise selon norme DIN 43 650/ISO 4400
Branchement du capteur de position	Prise spéciale
Courant d'alimentation de l'électro-aimant	max. 3,7 A
Résistance de la bobine R_{20}	2,5 Ω
Consommation max. pour charge 100% et température de service	60 VA max

Statiques/Dynamiques

Hystérésis	$\leq 0,3\%$
Seuil d'inversion	$\leq 0,2\%$
Dispersion pour $p_{max.}$	env. 6%
Temps de réponse pour une course	
	de 100%
de 10%	25 ms

Toute caractéristique en liaison avec l'amplificateur électronique proportionnel: PV 60

Kennlinie
Performance curve
Courbe caractéristique
 $v = 35 \text{ mm}^2/\text{s}$

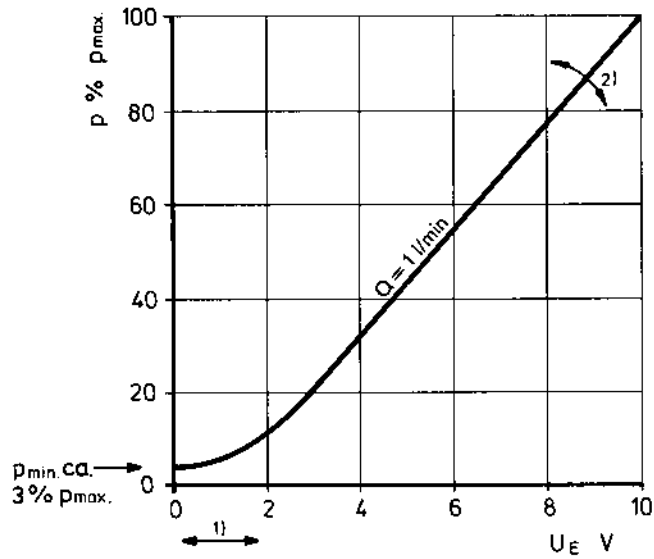

► **Ventilverstärker**
 1) Nullpunkt-Justierung
 2) Empfindlichkeits-Justierung

►► **Valve amplifier**
 1) Zero adjustment
 2) Gain adjustment

►►► **Amplificateur de valve**
 1) Tarage du zéro
 2) Tarage du gain

Abmessungen
Dimensions
Cotes d'encombrement

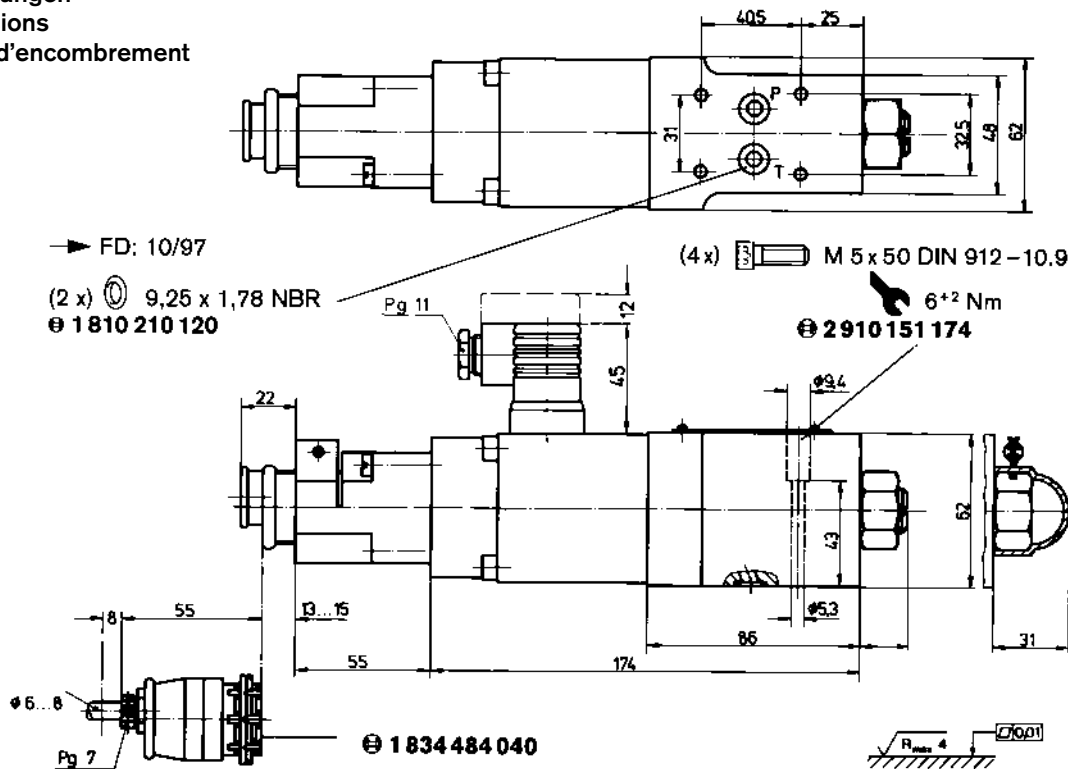

► Abmessungen des Anschlusslochbildes NG 6 ISO 4401 siehe Seite 212

►► Dimensions of mounting hole configuration NG 6 ISO 4401 see page 212

►►► Cotes du plan de pose NG 6 ISO 4401 voir page 212

NG 6 (PDL)

1

Lineare Druckbegrenzungsventile Linear pressure relief valves Limiteurs de pression linéaire



Funktion
Function
Fonction

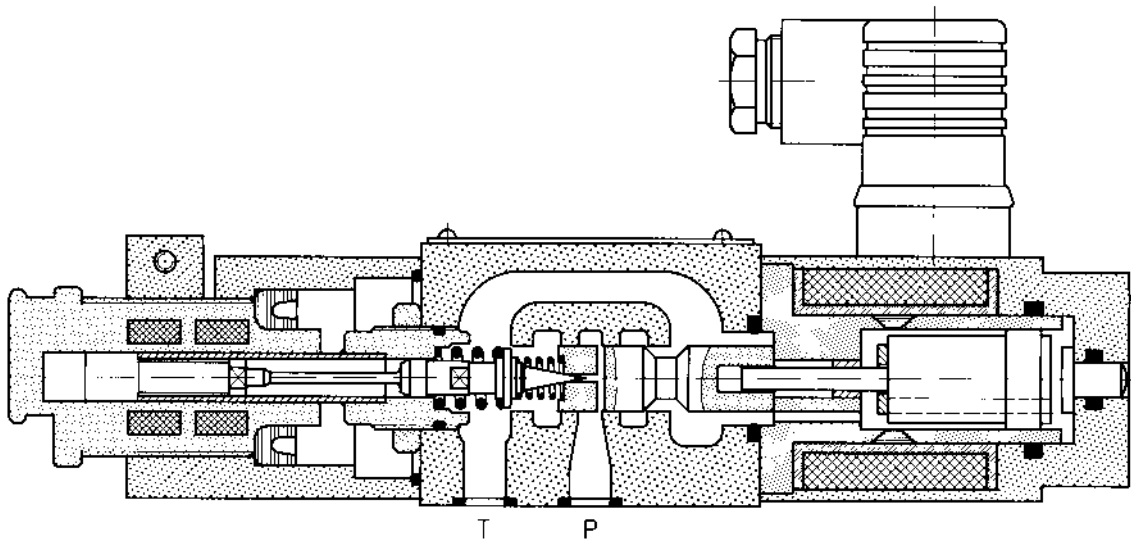

▶ Vorsteuerstufe ($Q_{nom.} = 1 \text{ l/min}$)
mit Lageregelung

▶▶ Pilot stage ($Q_{nom.} = 1 \text{ l/min}$)
with position control

▶▶▶ Étage pilote ($Q_{nom.} = 1 \text{ l/min}$)
avec régulation de position

Sinnbild Symbol Symbole	A/VA max 	$Q_{nom.}$ [l/min]	$p_{nom.}$ [bar]		[kg]	Ⓔ
③	2,7/35	1	3 ... 80	6-K	2,3	0 811 402 023
			4 ... 180	7-K		0 811 402 022
			5 ... 250	8-K		0 811 402 021
			6 ... 315			0 811 402 020
(4 x)						2 910 151 166
K	Seite Page 266	PDL 1		6-K	0,2	0 811 405 095
				7-K	0,2	0 811 405 100
				8-K	0,3	B 830 303 387



Allgemeines

Das PDL-Ventil gehört zur Gruppe der Proportional-Druckventile. Die Position des Ventilsitzes wird über den Proportionalmagnet eingestellt und über das am Ventilkegel angebundene Wegmesssystem erfasst.

Entsprechend der Sollwertvorgabe ändert sich der Magnetstrom. Dieser bewirkt unterschiedliche Magnetkräfte, die den Ventilsitz positionieren. Die Gegenkraft wird über die auf den Ventilkegel wirkende Feder aufgebaut. Das Ergebnis der Anordnung des Wegaufnehmers auf der Ventilkegel-seite ist ein linearer Zusammenhang zwischen dem elektrischen Eingangssignal und dem Regeldruck.



General

The PDL valve is a proportional pressure valve. The valve seating position is adjusted by the proportional solenoid, while the position measurement system attached to the valve cone determines the position.

The solenoid current is adjusted according to the prescribed setpoint. This results in variations in the magnetic forces which position the valve. The counterforce is provided by the spring which exerts pressure on the valve cone. Placing the position transducer on the valve cone results in a linear relationship between the electrical input signal and the control pressure.



Généralités

La valve PDL fait partie du groupe des valves de réglage de pression proportionnelles. La position du siège est réglée par un aimant à action proportionnelle et saisie par le capteur de position solidaire du clapet.

Le courant magnétique varie en fonction du signal de consigne. Il induit différentes forces magnétiques qui positionnent le siège de valve. La force de réaction est développée par le ressort agissant sur le pointeau. L'implantation du capteur de position sur le côté du pointeau résulte en un rapport linéaire entre le signal d'entrée électrique et la pression de régulation.



Kenngößen

Allgemein

Bauart	Sitzventil		
Betätigung	Proportionalmagnet mit Lageregelung		
Anschlussart	Plattenanschluss, Lochbild NG 6 (ISO 4401)		
Einbaulage	waagrecht, senkrecht Magnet oben		
Umgebungstemperatur	-20 ... +50 °C		

Hydraulisch

Druckmittel	Hydrauliköl nach DIN 51 524 ... 535, andere Medien nach Rückfrage			
Viskosität, empfohlen max. zulässig	20 ... 100 mm ² /s			
	10 ... 800 mm ² /s			
Druckmitteltemperatur	-20 ... +80 °C			
Filterung	Zulässige Verschmutzungs-klasse des Druckmittels nach NAS 1638		Zu erreichen mit Filter	
	8		β _x = 75	
	9		X = 10	
	10		20	
Entsprechend Betriebssicherheit und Lebensdauer	8		20	
	9		25	
	10		25	
Durchflussrichtung	siehe Sinnbild			
Nennndruck (bei Q = 1 l/min)	80	180	250	315 bar
Minimaldruck (bei Q = 1 l/min)	3	4	5	6 bar
Hinweis: Bei Q _{max} = 3 l/min erhöhen sich die angegebenen Drücke				

Zusätzliche Maximaldruckabsicherung erforderlich

Max. Betriebsdruck (statisch)	Anschluss P: 315 bar Anschluss T: ≤ 200 bar
-------------------------------	--

Elektrisch

Relative Einschaltdauer	100% ED
Schutzart	IP 65 nach DIN 40 050 und IEC 14 434/5
Anschluss Magnet	Gerätesteckdose DIN 43 650/ISO 4400
Anschluss Wegaufnehmer	Spezialsteckdose
Magnetstrom	max. 2,7 A
Spulenwiderstand R ₂₀	3 Ω
Max. Leistungsaufnahme bei 100% Last und Betriebstemperatur	35 VA max

Statisch/Dynamisch

Hysterese	≤ 1%
Umkehrspanne	≤ 0,8%
Linearitätsabweichung	≤ 2%
Stellzeit 100% Signalsprung	45 ms
	10% Signalsprung

Alle Kenngößen in Verbindung mit Proportionalverstärker: PDL 1



Characteristics

General

Construction	Poppet valve
Actuation	Proportional solenoid with position control
Connection type	Subplate, mounting hole configuration NG 6 (ISO 4401)
Mounting position	horizontal, vertical solenoid at top
Ambient temperature range	-20 ... +50 °C

Hydraulic

Pressure medium	Hydraulic oil as per DIN 51 524 ... 535, other fluids after prior consultation			
Viscosity, recommended max. permitted	20 ... 100 mm ² /s			
	10 ... 800 mm ² /s			
Pressure medium temperature	-20 ... +80 °C			
Filtration	Permissible contamination class of pressure medium as per NAS 1638		Achieved using filter $\beta_x = 75$	
In line with operational reliability and service life	8		X = 10	
	9		20	
	10		25	
Flow direction	cf. symbol			
Nominal pressure (at Q = 1 l/min)	80	180	250	315 bar
Minimum pressure (at Q = 1 l/min)	3	4	5	6 bar
Note: At $Q_{max.} = 3$ l/min, the pressures stated here increase				

Additional maximum pressure protection required

Max. working pressure (static)	Port P: 315 bar Port T: ≤ 200 bar
--------------------------------	---

Electrical

Cyclic duration factor	100%
Degree of protection	IP 65 as per DIN 40 050 and IEC 14 434/5
Solenoid connector	Connector DIN 43 650/ISO 4400
Position transducer connector	Special connector
Solenoid current	max. 2.7 A
Coil resistance R_{20}	3 Ω
Max. power consumption at 100% load and operational temperature	35 VA max

Static/Dynamic

Hysteresis	$\leq 1\%$
Range of inversion	$\leq 0.8\%$
Manufacturing tolerance $p_{max.}$	$\leq 2\%$
Response time 100% signal change 10% signal change	45 ms
	25 ms

All characteristic values in connection with proportional amplifier: PDL 1



Caractéristiques

Générales

Construction	Valve à clapet
Commande	Aimant à action proportionnelle avec régulation de position
Raccordement	Embase selon plan de pose NG 6 (ISO 4401)
Position de montage	horizontale, verticale électro-aimant en haut
Température ambiante	-20 ... +50 °C

Hydrauliques

Fluide	Fluide hydraulique selon norme DIN 51 524 ... 535, autre fluide sur demande			
Viscosité, conseillée max. admissible	20 ... 100 mm ² /s			
	10 ... 800 mm ² /s			
Température du fluide	-20 ... +80 °C			
Filtration	Classe de pollution admissible du fluide selon NAS 1638		Avec un filtre $\beta_x = 75$	
	8	X = 10		
	9	20		
	10	25		
Selon sécurité de fonctionnement et durée de vie				
Sens d'écoulement	voir symbole			
Pression nominale (pour Q = 1 l/min)	80	180	250	315 bar
Pression minimale (pour Q = 1 l/min)	3	4	5	6 bar
Remarque: Les pressions indiquées augmentent pour $Q_{max.} = 3$ l/min				

Protection supplémentaire obligatoire contre les pressions maximales

Pression de service max. (statique)	Orifice P: 315 bar Orifice T: ≤ 200 bar
-------------------------------------	---

Electriques

Facteur de marche réelle	FM 100%
Degré de protection	IP 65 selon norme DIN 40 050 et IEC 14 434/5
Branchement électro-aimant	par prise selon norme DIN 43 650/ISO 4400
Branchement du capteur de position	Prise spéciale
Courant d'alimentation de l'électro-aimant	max. 2,7 A
Résistance de la bobine R_{20}	3 Ω
Consommation max. pour charge 100% et température de service	35 VA max

Statiques/Dynamiques

Hystérésis	$\leq 1\%$
Seuil d'inversion	$\leq 0,8\%$
Ecart de linéarité $p_{max.}$	$\leq 2\%$
Temps de réponse pour une course de 100%	45 ms
	de 10%

Toute caractéristique en liaison avec l'amplificateur électronique proportionnel: PDL 1

1

Kennlinie
Performance curve
Courbe caractéristique
 $v = 35 \text{ mm}^2/\text{s}$

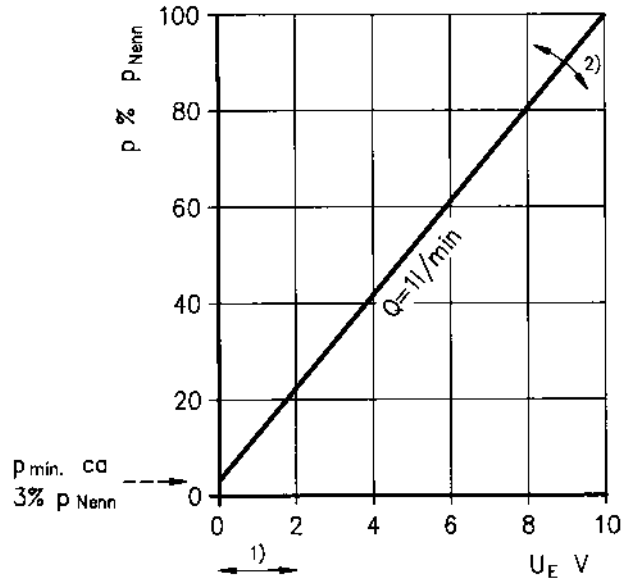

Ventilverstärker
 1) Nullpunkt-Justierung
 2) Empfindlichkeits-Justierung

Valve amplifier
 1) Zero adjustment
 2) Gain adjustment

Amplificateur de valve
 1) Tarage du zéro
 2) Tarage du gain

Abmessungen
Dimensions
Cotes d'encombrement

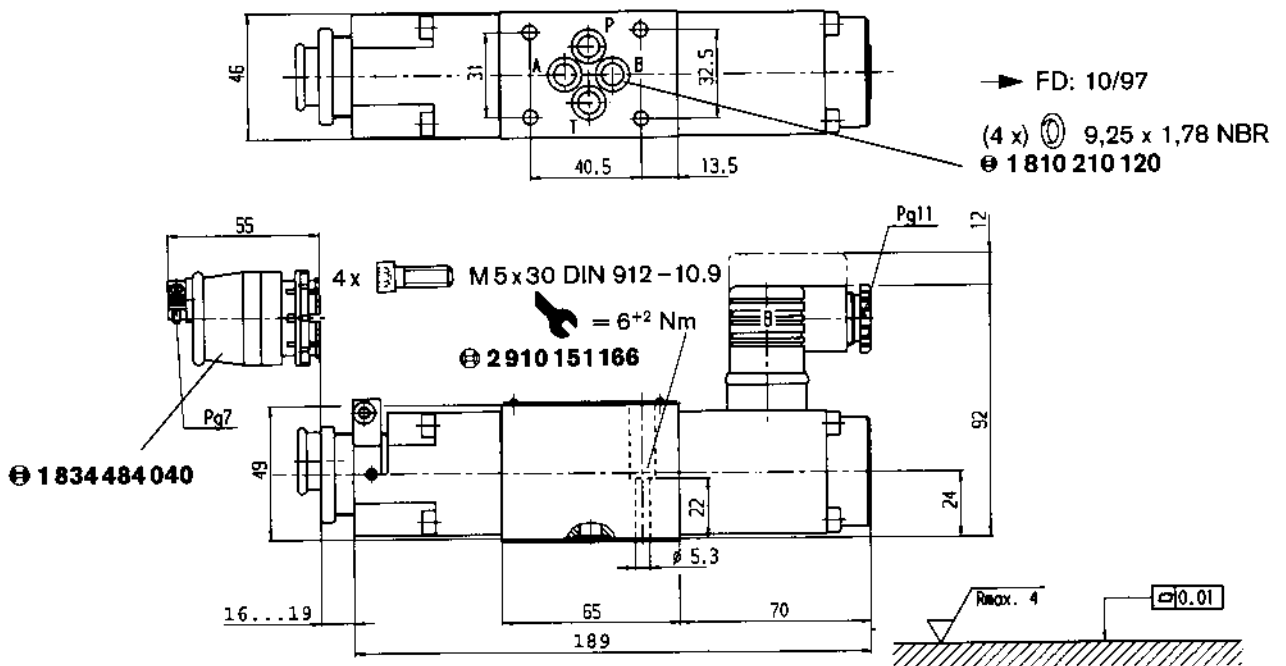

Abmessungen des Anschlusslochbildes NG 6 ISO 4401
 siehe Seite 212

Dimensions of mounting hole configuration NG 6 ISO 4401
 see page 212

Cotes du plan de pose NG 6 ISO 4401
 voir page 212

NG 6

Druckbegrenzungsventile mit OBE Pressure relief valves with OBE Limiteurs de pression avec OBE



1

Funktion
Function
Fonction

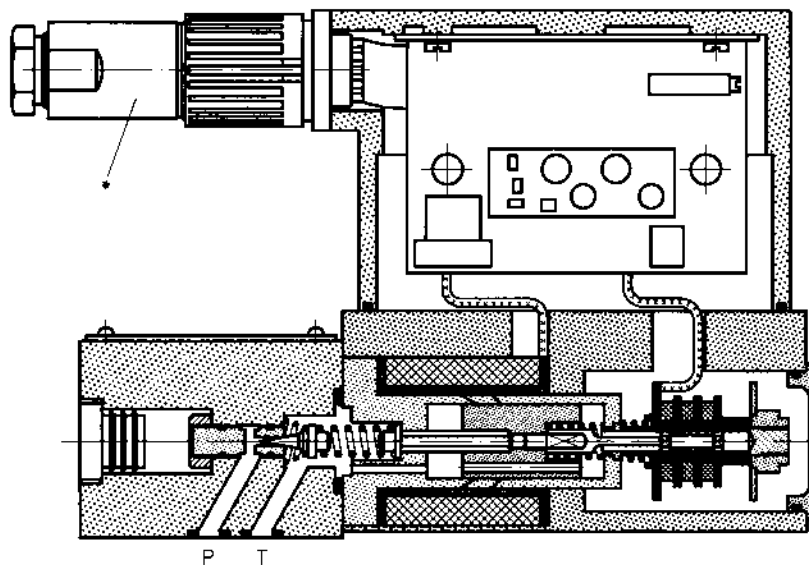
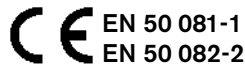

▶ Vorsteuerstufe ($Q_{nom.} = 1 \text{ l/min}$)
mit Lageregelung

▶▶ Pilot stage ($Q_{nom.} = 1 \text{ l/min}$)
with position control

▶▶▶ Étage pilote ($Q_{nom.} = 1 \text{ l/min}$)
avec régulation de position

Sinnbild Symbol Symbole	V/VA max 24 V= 40 VA max $U_{D-E} 0 \dots +10 \text{ V}$	$Q_{nom.}$ [l/min]	$P_{nom.}$ [bar]		[kg]	Ⓢ
④ OBE 		1	3 ... 80		2,7	0 811 402 072
			4 ... 180			0 811 402 071
			5 ... 250			0 811 402 073
			8 ... 315			0 811 402 070
(4 x)						2 910 151 166
* Stecker 7-polig Plug 7-pole Connecteur 7 pôles Seite Page 241						1 834 482 022
						1 834 482 026
						1 834 482 023
						1 834 482 024
						1 834 484 252

Variante 4 ... 20 mA-Signal auf Anfrage
4 ... 20 mA version on request
Variante signal 4 ... 20 mA sur demande

Kenngrößen

Allgemein

Bauart	Sitzventil
Betätigung	Proportionalmagnet mit Lageregelung und mit eingebauter Elektronik
Anschlussart	Plattenanschluss, Lochbild NG 6 (ISO 4401)
Einbaulage	beliebig
Umgebungstemperatur	-20 ... +50 °C
Rüttelfestigkeit, Prüfbedingung	max. 25 g, Raumschüttelprüfung in allen Richtungen (24 h)

Hydraulisch

Druckmittel	Hydrauliköl nach DIN 51 524 ... 535, andere Medien nach Rückfrage		
Viskosität, empfohlen max. zulässig	20 ... 100 mm ² /s		
	10 ... 800 mm ² /s		
Druckmitteltemperatur	-20 ... +70 °C		
Entsprechend Betriebssicherheit und Lebensdauer	Zulässige Verschmutzungsstufe des Druckmittels nach NAS 1638	Zu erreichen mit Filter $\beta_x = 75$	
	8	X = 10	
	9	20	
	10	25	

Durchflussrichtung	siehe Sinnbild			
Nenndruck (bei Q = 1 l/min)	80	180	250	315 bar
Minimaldruck (bei Q = 1 l/min)	3	4	5	8 bar
	Hinweis: Bei $Q_{max} = 1,5$ l/min erhöhen sich die angegebenen Drücke			

Max. Betriebsdruck	Anschluss P: 315 bar Anschluss T: 250 bar			
--------------------	--	--	--	--

Statisch/Dynamisch

Hysterese	$\leq 0,2\%$
Umkehrspanne	$\leq 0,1\%$
Exemplarstreuung	$< \pm 5\%$
Stellzeit 100% Signalsprung	30 ms
	10 ms
Temperaturdrift	$< 1\%$ bei $\Delta T = 40$ °C
Konformität	EN 50 081-1
	EN 50 082-2

Elektrische Kenngrößen

siehe Seite 216 (OBE)

Steckerbelegung 7P

Ventil ... mit Lageregelung

Version: $U_E = 0 \dots +10$ V
 $R_i = 100$ k Ω

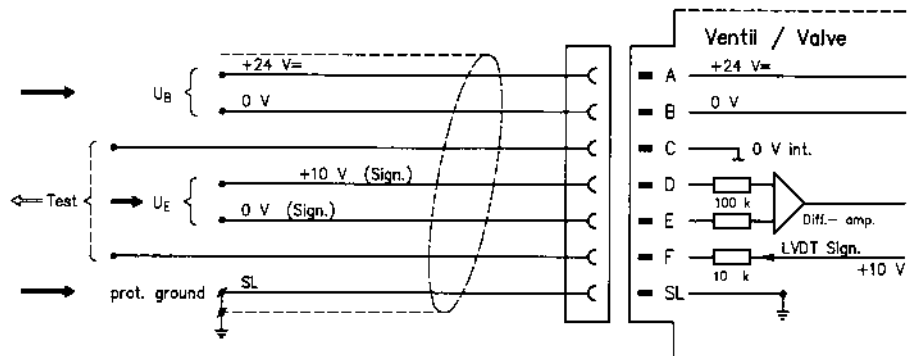

Version: $I_E = 4 \dots 20$ mA
Bürde = 200 Ω

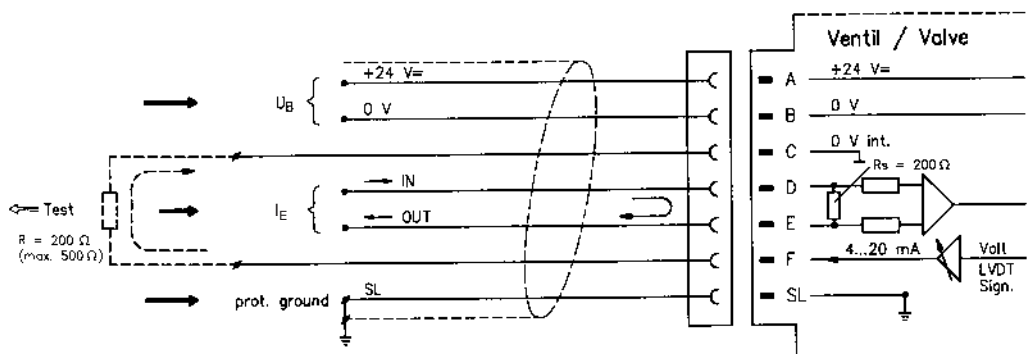

►► **Characteristics**

General				
Construction	Poppet valve			
Actuation	Proportional solenoid with position control and on-board electronics			
Connection type	Subplate, mounting hole configuration NG 6 (ISO 4401)			
Mounting position	optional			
Ambient temperature range	-20 ... +50 °C			
Vibration resistance, test condition	max. 25 g, shaken in 3 dimensions (24 h)			
Hydraulic				
Pressure medium	Hydraulic oil as per DIN 51 524 ... 535, other fluids after prior consultation			
Viscosity, recommended	20 ... 100 mm ² /s			
max. permitted	10 ... 800 mm ² /s			
Pressure medium temperature	-20 ... +70 °C			
Filtration	Permissible contamination class of pressure medium as per NAS 1638	Achieved using filter		
In line with operational reliability and service life	8	β _x = 75		
	9	X = 10		
	10	20		
Flow direction	cf. symbol			
Nominal pressure (at Q = 1 l/min)	80	180	250	315 bar
Minimum pressure (at Q = 1 l/min)	3	4	5	8 bar
	Note: At Q _{max} = 1.5 l/min, the pressures stated here increase			
Max. working pressure	Port P: 315 bar Port T: 250 bar			
Static/Dynamic				
Hysteresis	≅ 0.2%			
Range of inversion	≅ 0.1%			
Manufacturing tolerance	< ± 5%			
Response time 100% signal change	30 ms			
10% signal change	10 ms			
Thermal drift	< 1%, at ΔT = 40 °C			
Conformity	EN 50 081-1 EN 50 082-2			
Electrical characteristics				
	see page 216 (OBE)			

►►

Pin assignment 7P
Valve ... with position control

Version: U_E = 0 ... +10 V
R_i = 100 kΩ

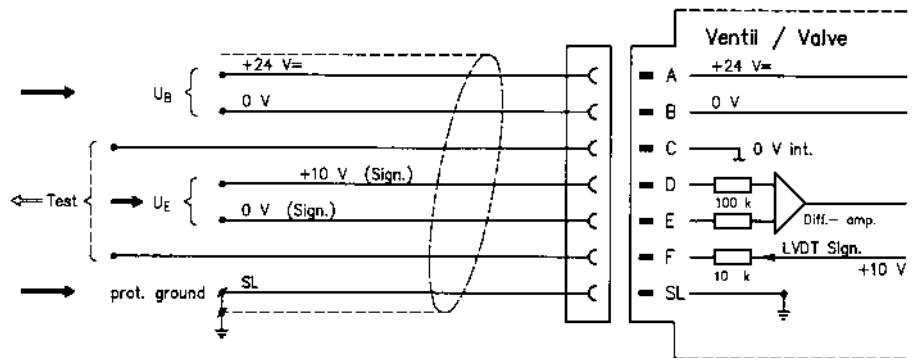

Version: I_E = 4 ... 20 mA
Load = 200 Ω

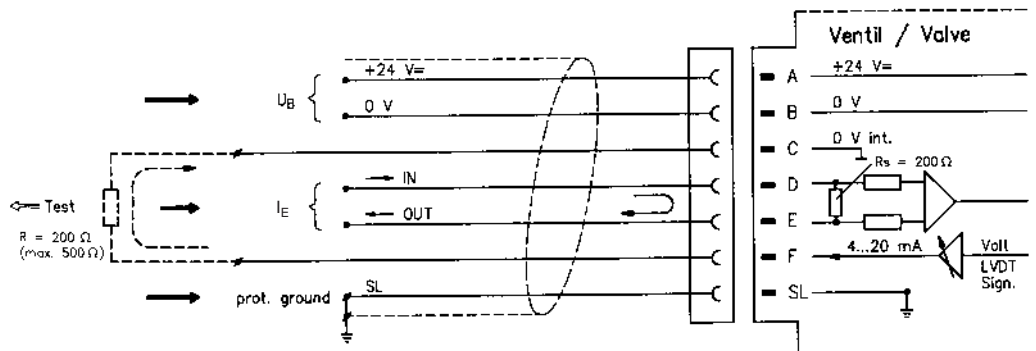

►►► **Caractéristiques Générales**

Construction	Valve à clapet			
Commande	Aimant à action proportionnelle avec régulation de position avec amplificateur intégré			
Raccordement	Embase selon plan de pose NG 6 (ISO 4401)			
Position de montage	indifférente			
Température ambiante	-20 ... +50 °C			
Vibrations, condition du test	max. 25 g, 3 dimensions (24 h)			

Hydrauliques

Fluide	Fluide hydraulique selon norme DIN 51 524 ... 535, autre fluide sur demande			
Viscosité, conseillée	20 ... 100 mm ² /s			
max. admissible	10 ... 800 mm ² /s			
Température du fluide	-20 ... +70 °C			
Filtration	Classe de pollution admissible du fluide selon NAS 1638	Avec un filtre		
Selon sécurité de fonctionnement et durée de vie	8	β _v = 75		
	9	X = 10		
	10	20		
		25		
Sens d'écoulement	voir symbole			
Pression nominale (pour Q = 1 l/min)	80	180	250	315 bar
Pression minimale (pour Q = 1 l/min)	3	4	5	8 bar
Pression de service max.	Remarque: Les pressions indiquées augmentent pour Q _{max.} = 1,5 l/min Orifice P: 315 bar Orifice T: 250 bar			

Statiques/Dynamiques

Hystérésis	≤ 0,2%
Seuil d'inversion	≤ 0,1%
Dispersion	< ± 5%
Temps de réponse pour une course de 100%	30 ms
de 10%	10 ms
Dérive en température	< 1% pour ΔT = 40 °C
Conformité	EN 50 081-1 EN 50 082-2

Caractéristiques électriques

voir page 216 (OBE)



**Affectation du connecteur 7P
Valve ... avec régulation de position**

Version: U_E = 0 ... +10 V
R_i = 100 kΩ

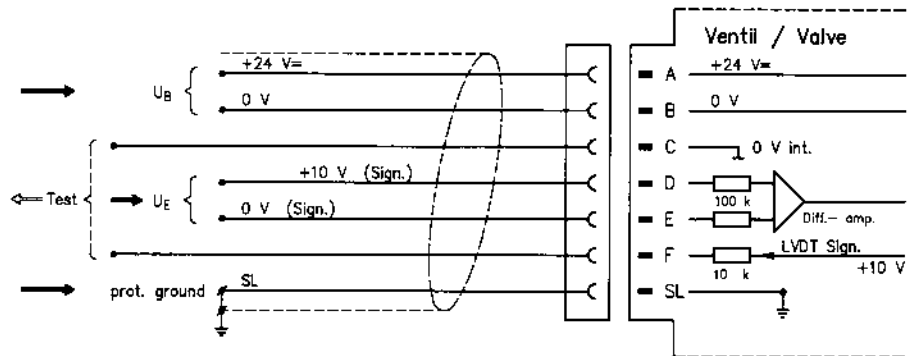

Version: I_E = 4 ... 20 mA
Charge = 200 Ω

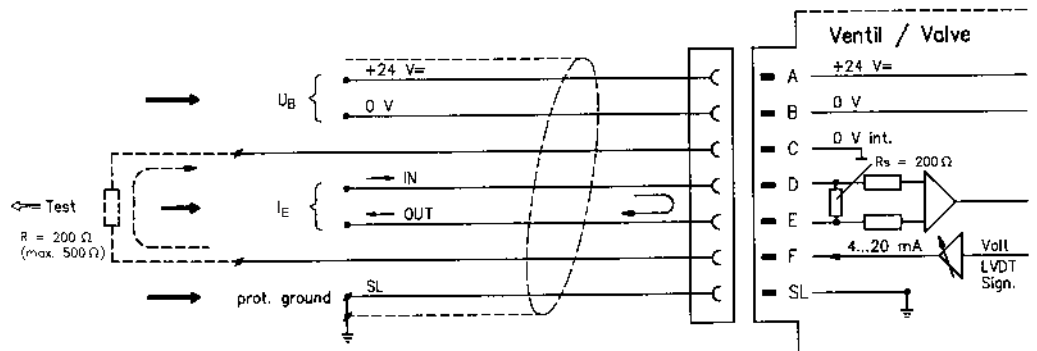

Kennlinie
Performance curve
Courbe caractéristique
 $v = 35 \text{ mm}^2/\text{s}$

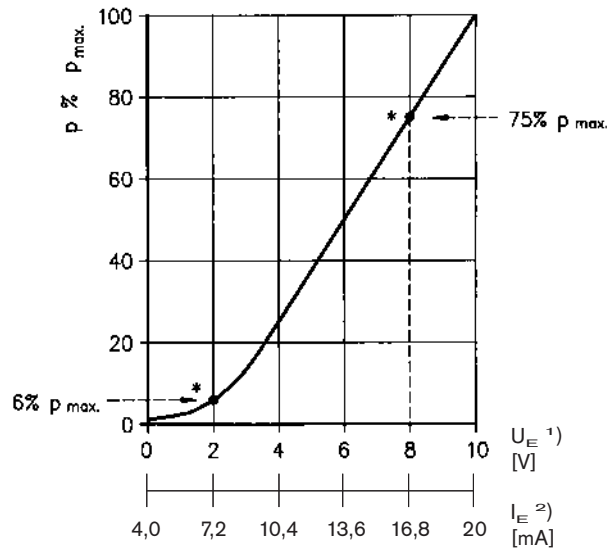

► * WerkEinstellung bei $Q = 1 \text{ l/min}$
 $\pm 2\%$ Exemplarstreuung
 1) Version: $U_E = 0 \dots +10 \text{ V}$
 2) Version: $I_E = 4 \dots 20 \text{ mA}$

►► * Factory setting at $Q = 1 \text{ l/min}$
 $\pm 2\%$ manufacturing tolerance
 1) Version: $U_E = 0 \dots +10 \text{ V}$
 2) Version: $I_E = 4 \dots 20 \text{ mA}$

►►► * Réglage par l'usine à $Q = 1 \text{ l/min}$
 $\pm 2\%$ dispersion
 1) Version: $U_E = 0 \dots +10 \text{ V}$
 2) Version: $I_E = 4 \dots 20 \text{ mA}$

Abmessungen
Dimensions
Cotes d'encombrement

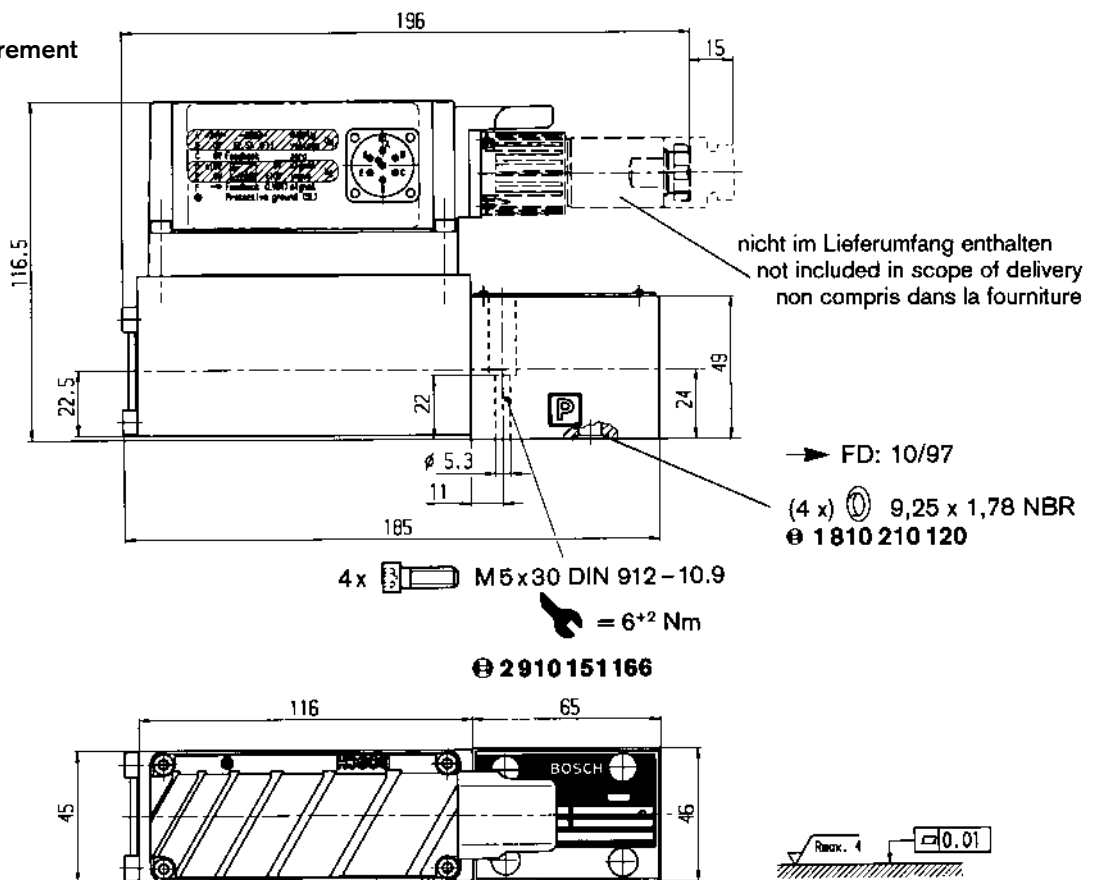

► Abmessungen des Anschlusslochbildes NG 6 ISO 4401
 siehe Seite 212

►► Dimensions of mounting hole configuration NG 6 ISO 4401
 see page 212

►►► Cotes du plan de pose NG 6 ISO 4401
 voir page 212