

NG 10

Proportional-Wegeventile

Proportional directional control valves

Distributeurs proportionnels

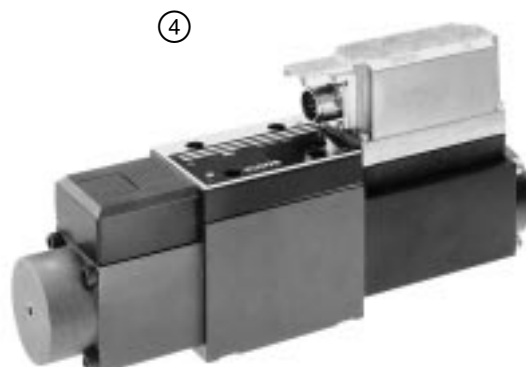
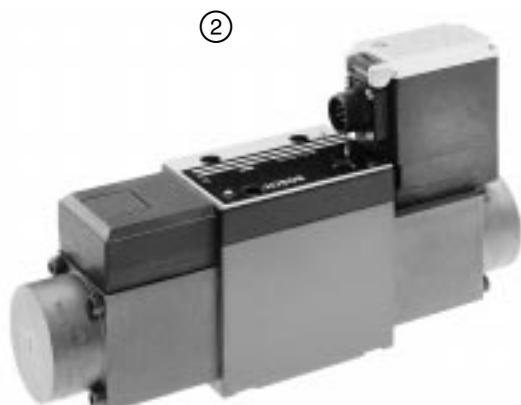
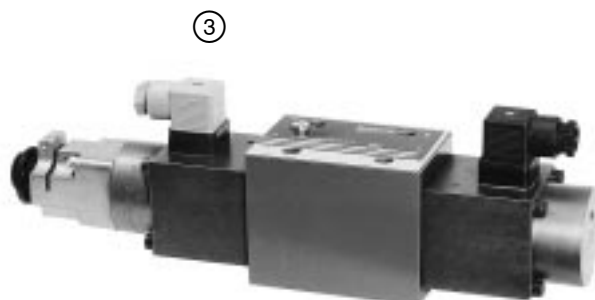

7

▶ ① **ohne** Lageregelung
Version: Standard 2,5 A

▶▶ ② **ohne** Lageregelung und
eingebauter Elektronik – OBE

▶▶▶ ③ **mit** Lageregelung
Version: LVDT – AC

▶▶▶▶ ④ **mit** Lageregelung und
eingebauter Elektronik – OBE

▶▶▶▶ ① **without** position control
Version: Standard 2.5 A

▶▶▶▶▶ ② **without** position control and
on-board electronics – OBE

▶▶▶▶▶▶ ③ **with** position control
Version: LVDT – AC

▶▶▶▶▶▶▶ ④ **with** position control and
on-board electronics – OBE

▶▶▶▶▶▶▶▶ ① **sans** régulation de position
Version: Standard 2,5 A

▶▶▶▶▶▶▶▶▶ ② **sans** régulation de position et
amplificateur intégré – OBE

▶▶▶▶▶▶▶▶▶▶ ③ **avec** régulation de position
Version: LVDT – AC

▶▶▶▶▶▶▶▶▶▶▶ ④ **avec** régulation de position et
amplificateur intégré – OBE









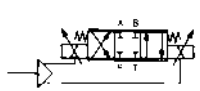

Bauart: Schieberventil

Construction: Spool type valve

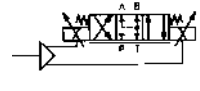
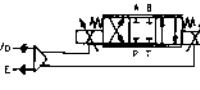

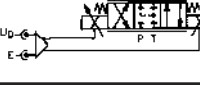
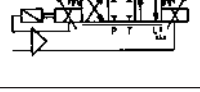
Construction: Distributeur à tiroir

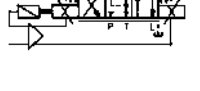
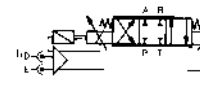
NG 10

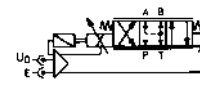
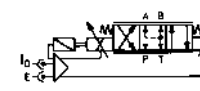
Bestellübersicht Ordering range Gamme de commande

Sinnbild Symbol Symbole	 A/VA max	Δp [bar]	$Q_{nom.}$ [l/min]		$p_{max.}$ [bar]		Seite Page Page	Ⓢ		
			Q_A	Q_B						
①  01	2,5/55 ($R_L = 5,8 \Omega$)	5	32	32	P, A, B: 315 T: 250		176	0 811 404 830		
			63	63					0 811 404 832	
			32	32						0 811 404 831
			63	63						0 811 404 833
①  01 + L										
②  OBE 01	24 V= 60 VA max $U_{D-E} + 10 V$	5	35	35	P, A, B: 315 T: 250		182	0 811 404 852		
			65	65				0 811 404 850		
			35	35				0 811 404 853		
			65	65				0 811 404 851		
②  OBE 01 + L										
③  01	3,7/60	5	32	32	P, A, B: 315 T: 250		188	0 811 404 003		
			63	63				0 811 404 001		
			63	36,5				0 811 404 086		
			32	32				0 811 404 081		
			63	63				0 811 404 080		
			63	36,5				0 811 404 087		
③  01 + L										
④  OBE 01	24 V= 60 VA max $U_{D-E} + 10 V$	5	50	50	P, A, B: 315 T: 200		194	0 811 404 770		
			80	80				0 811 404 771		
			80	50				0 811 404 774		
			50	50				0 811 404 772		
			80	80				0 811 404 773		
			80	50				0 811 404 777		
④  OBE 01 + L										
④  OBE 01 + L	24 V= 60 VA max $I = 4 \dots 20 \text{ mA}$	5	50	50				0 811 404 778		

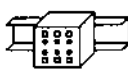
01 + L Mittelstellung mit Leckölentlastung / Central position with leakage drain / Position zéro avec drain des fuites

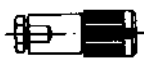
Sinnbild Symbol Symbole	Amplifier type			Seite Page Page	Ⓢ
	mit Rampe ● with ramp avec rampe	Alphanumerik Alpha numeric Code alphanumérique			
M 	●	2 M 2.5 – RGC2	1-M	253	0 811 405 106
K 	●	2 M 45 – 2.5 A	1-K	266	0 811 405 080
	●	WV 60 – RGC2	2-K		0 811 405 120
	●	WV 60 – RGC4	3-K		0 811 405 138
	Stecker 7-polig für OBE Plug 7-pole for OBE Connecteur 7 pôles pour OBE			241	

NG 10

Wegeventile

Directional control valves

Distributeurs

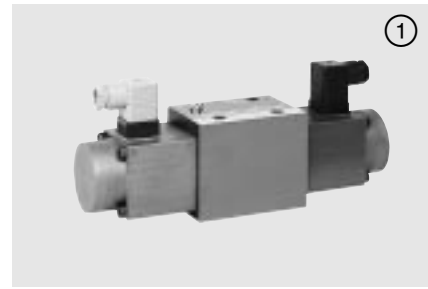

Funktion
Function
Fonction

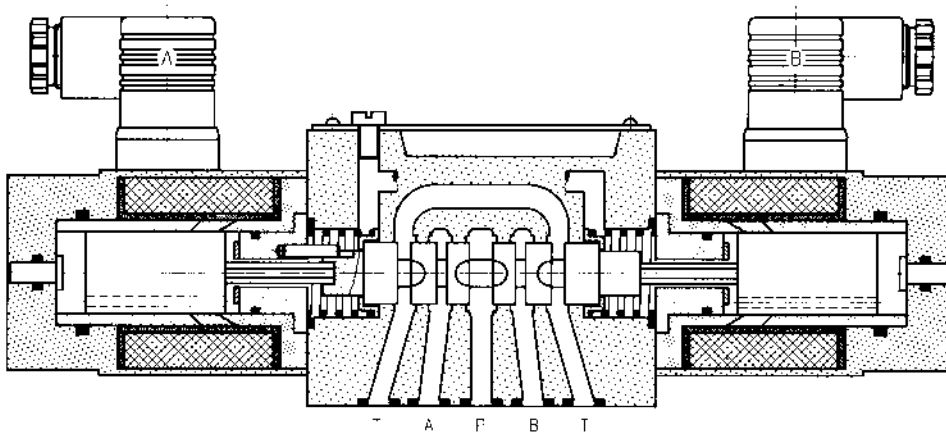







7

▶ ohne Lageregelung

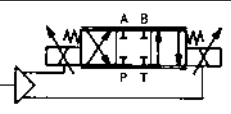
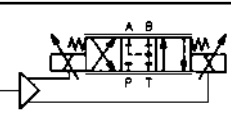
▶▶ without position control

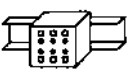
▶▶▶ sans régulation de position

Sinnbild Symbol Symbole		Δp [bar]	$Q_{nom.}$ [l/min]	$p_{max.}$ [bar]		[kg]	Ⓢ	
	A/VA max 2,5/55 ($R_L = 5,8 \Omega$)*	5	Q_A Q_B					
①  01			32 32	P, A, B: 315 T: 250	1-M 1-K	7,7	0 811 404 830	
			63 63				0 811 404 832	
①  01 + L			32 32				0 811 404 831	
			63 63				0 811 404 833	
(4 x)  M 6 x 35 DIN 912-10.9								2 910 151 207
M 	253		2 M 2.5 - RGC2		1-M	0,3	0 811 405 106	
K 	266		Seite Page	2 M 45 - 2.5 A		1-K	0,25	0 811 405 080

* Verstärker mit Ventil nur für $U_B = 24 V_{nom.}$ zulässig

* Amplifier with valve only permitted for $U_B = 24 V_{nom.}$

* Amplificateur avec valve pour $U_B = 24 V_{nom.}$ seulement autorisé

Kenngrößen

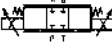
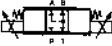
Allgemein		
Bauart	Schieberventil	
Betätigung	Proportionalmagnet ohne Lageregelung	
Anschlussart	Plattenanschluss, Lochbild NG 10 (ISO 4401)	
Einbaulage	beliebig	
Umgebungstemperatur	-20 ... +50 °C	
Hydraulisch		
Druckmittel	Hydrauliköl nach DIN 51 524 ... 535, andere Medien nach Rückfrage	
Viskosität, empfohlen max. zulässig	20 ... 100 mm ² /s	
	10 ... 800 mm ² /s	
Druckmitteltemperatur	-20 ... +80 °C	
Filterung	Zulässige Verschmutzungsstufe des Druckmittels nach NAS 1638	Zu erreichen mit Filter β _x = 75
	8	X = 10
	9	20
	10	25
Entsprechend Betriebssicherheit und Lebensdauer		
Durchflussrichtung	siehe Sinnbild	
Nenndurchfluss (bei Δp = 5 bar)*	32	63 l/min (pro Kanal)
Lecköl/Steuerkante (Δp = 100 bar)		A → T = 80 cm ³ /min
		B → T = 80 cm ³ /min
Leckölentlastung (Δp = 5 bar)		A → T = 0,4 ... 0,8 l/min
		B → T = 0,4 ... 0,8 l/min
Max. Betriebsdruck	Anschluss P, A, B: 315 bar	
	Anschluss T: 250 bar	
Elektrisch		
Relative Einschaltdauer	100% ED	
Schutzart	IP 65 nach DIN 40 050 und IEC 14 434/5	
Anschluss Magnet	Gerätesteckdose DIN 43 650/ISO 4400	
Magnetstrom	max. 2,5 A	
Spulenwiderstand R ₂₀	5,8 Ω	
Max. Leistungsaufnahme bei 100% Last und Betriebstemperatur	55 VA max	
Statisch/Dynamisch		
Hysterese	≤ 6%	
Umkehrspanne	≤ 4%	
Stellzeit 100% Signalsprung	100 ms	

Alle Kenngrößen in Verbindung mit Proportionalverstärker: 2 M 45 – 2.5 A

*** Nenndurchfluss**

Dieser bezieht sich immer auf eine Druckdifferenz an der Drosselstelle von Δp = 5 bar. Der Durchfluss bei anderen Differenzdrücken berechnet sich nach:

$$Q_x = Q_{nom.} \cdot \sqrt{\frac{\Delta p_x}{5}}$$

Hierbei sind jedoch die **Einsatzgrenzen** zu beachten. Bei Überschreitung der Einsatzgrenzen treten Strömungskräfte auf, die zu unkontrollierbaren Schieberbewegungen führen. Durch die Verwendung von **Druckwaagen** wird Δp sicher begrenzt.



Characteristics

General

Construction	Spool type valve
Actuation	Proportional solenoid without position control
Connection type	Subplate, mounting hole configuration NG 10 (ISO 4401)
Mounting position	optional
Ambient temperature range	-20 ... +50 °C

Hydraulic

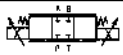
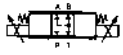
Pressure medium	Hydraulic oil as per DIN 51 524 ... 535, other fluids after prior consultation	
Viscosity, recommended	20 ... 100 mm ² /s	
max. permitted	10 ... 800 mm ² /s	
Pressure medium temperature	-20 ... +80 °C	
Filtration	Permissible contamination class of pressure medium as per NAS 1638	Achieved using filter β _x = 75
In line with operational reliability and service life	8	X = 10
	9	20
	10	25
Flow direction	cf. symbol	
Nominal flow (at Δp = 5 bar)*	32	63 l/min (per channel)
Leakage/Metering edge (Δp = 100 bar)		A → T = 80 cm ³ /min B → T = 80 cm ³ /min
Leakage drain (Δp = 5 bar)		A → T = 0.4 ... 0.8 l/min B → T = 0.4 ... 0.8 l/min
Max. working pressure	Ports P, A, B: 315 bar Port T: 250 bar	

Electrical

Cyclic duration factor	100%
Degree of protection	IP 65 as per DIN 40 050 and IEC 14 434/5
Solenoid connector	Connector DIN 43 650/ISO 4400
Solenoid current	max. 2.5 A
Coil resistance R ₂₀	5.8 Ω
Max. power consumption at 100% load and operational temperature	55 VA max

Static/Dynamic

Hysteresis	≤ 6%
Range of inversion	≤ 4%
Response time 100% signal change	100 ms

All characteristic values in connection with proportional amplifier: 2 M 45 – 2.5 A

* Nominal flow

This is always based on a pressure differential of Δp = 5 bar at the throttle point.

Where other pressure differentials are involved, flow is calculated according to the following formula:

$$Q_x = Q_{\text{nom.}} \cdot \sqrt{\frac{\Delta p_x}{5}}$$

However, the **operating limits** must be borne in mind here.

When the operating limits are exceeded, the ensuing flow forces lead to uncontrollable spool movements.

To achieve effective limitation of Δp, use is made of **pressure compensators**.



Caractéristiques

Générales

Construction	Distributeur à tiroir
Commande	Aimant à action proportionnelle sans régulation de position
Raccordement	Embase selon plan de pose NG 10 (ISO 4401)
Position de montage	indifférente
Température ambiante	-20 ... +50 °C

Hydrauliques

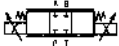
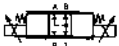
Fluide	Fluide hydraulique selon norme DIN 51 524 ... 535, autre fluide sur demande		
Viscosité, conseillée max. admissible	20 ... 100 mm ² /s		
	10 ... 800 mm ² /s		
Température du fluide	-20 ... +80 °C		
Selon sécurité de fonctionnement et durée de vie	Filtration	Classe de pollution admissible du fluide selon NAS 1638	Avec un filtre β _x = 75
		8	X = 10
		9	20
		10	25
Sens d'écoulement	voir symbole		
Débit nominal (pour Δp = 5 bar)*	32	63 l/min (par canal)	
Fuites internes/Arête de distribution (Δp = 100 bar)		A → T = 80 cm ³ /min B → T = 80 cm ³ /min	
Drainage de fuites internes (Δp = 5 bar)		A → T = 0,4 ... 0,8 l/min B → T = 0,4 ... 0,8 l/min	
Pression de service max.	Orifice P, A, B: 315 bar Orifice T: 250 bar		

Electriques

Facteur de marche réelle	FM 100%
Degré de protection	IP 65 selon norme DIN 40 050 et IEC 14 434/5
Branchement électro-aimant	par prise selon norme DIN 43 650/ISO 4400
Courant d'alimentation de l'électro-aimant	max. 2,5 A
Résistance de la bobine R ₂₀	5,8 Ω
Consommation max. pour charge 100% et température de service	55 VA max

Statiques/Dynamiques

Hystérésis	≤ 6%
Seuil d'inversion	≤ 4%
Temps de réponse pour une course de 100%	100 ms

Toute caractéristique en liaison avec l'amplificateur électronique proportionnel: 2 M 45 – 2.5 A

*** Débit nominal**

Toujours par rapport à une différence de pression à l'étranglement de Δp = 5 bar.

Le débit pour d'autres différences de pression se calcule comme suit:

$$Q_x = Q_{nom.} \cdot \sqrt{\frac{\Delta p_x}{5}}$$

Il faut néanmoins tenir compte des **limites d'utilisation.**

En cas de dépassement de ces plages d'utilisation, une pression trop élevée entraîne des déplacements de tiroir non contrôlés. L'utilisation de **balances de pression** permet de limiter en toute sécurité le Δp.

Kennlinie
Performance curve
Courbe caractéristique
 $v = 35 \text{ mm}^2/\text{s}$

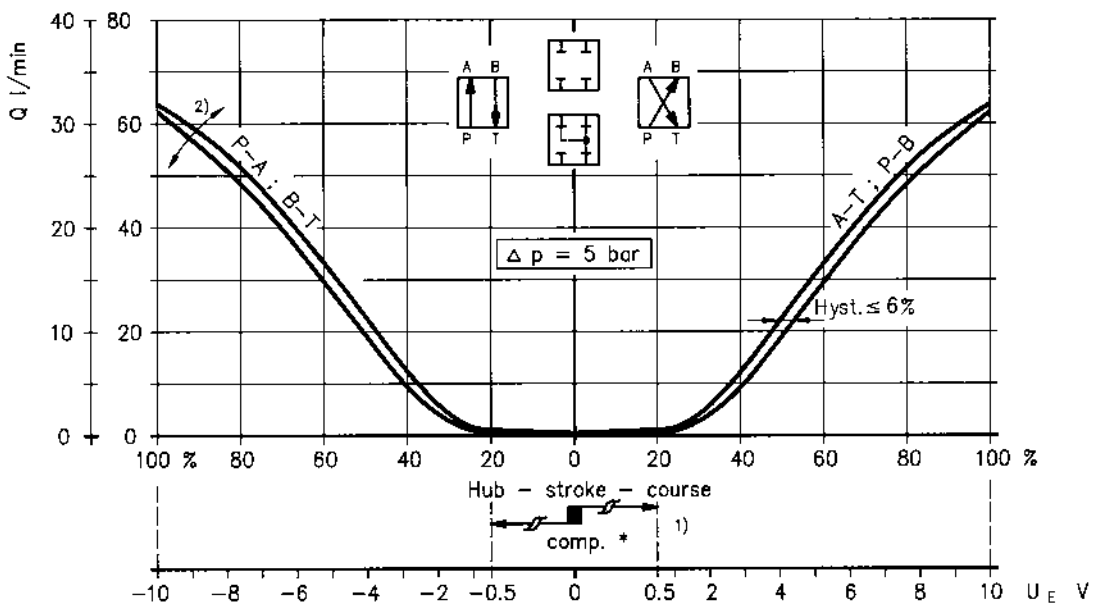

7

Ventilverstärker

- 1) Nullpunkt-Justierung
- 2) Empfindlichkeits-Justierung

Valve amplifier

- 1) Zero adjustment
- 2) Gain adjustment

Amplificateur de valve

- 1) Tarage du zéro
- 2) Tarage du gain

Einsatzgrenzen
Operating limits
Limites d'utilisation

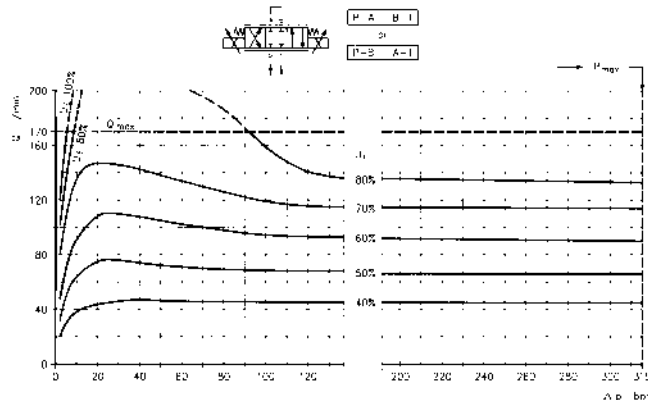
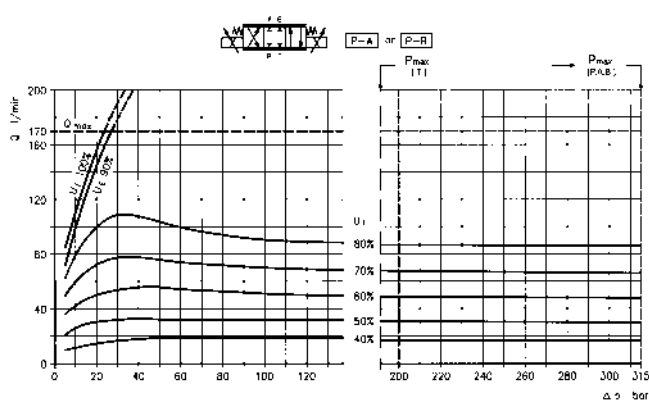

**Abmessungen
Dimensions
Cotes d'encombrement**

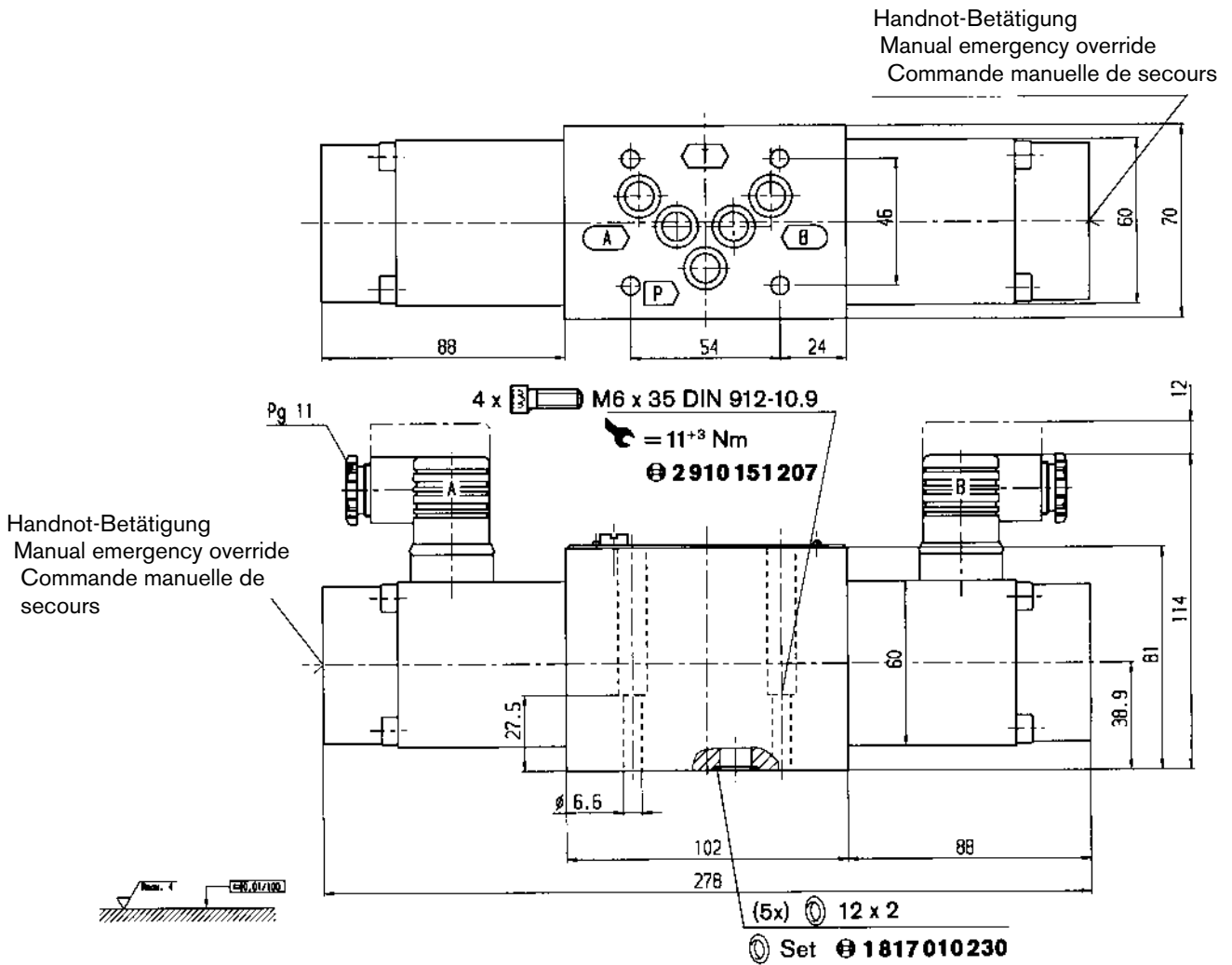

► Abmessungen des Anschlusslochbildes NG 10 ISO 4401 siehe Seite 212

►► Dimensions of mounting hole configuration NG 10 ISO 4401 see page 212

►►► Cotes du plan de pose NG 10 ISO 4401 voir page 212

NG 10

Wegeventile mit OBE

Directional control valves with OBE

Distributeurs avec OBE



Funktion
Function
Fonction

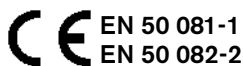



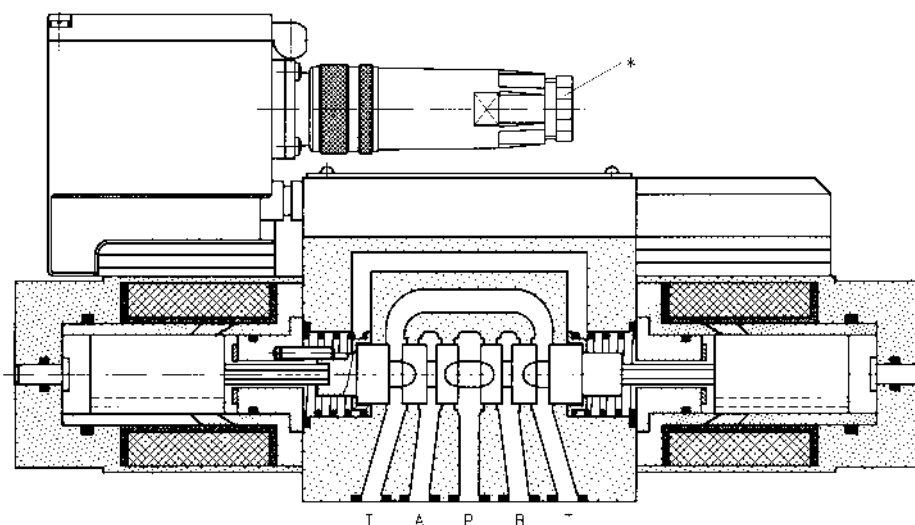



7

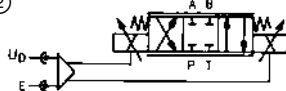

▶ ohne Lageregelung

▶▶ without position control

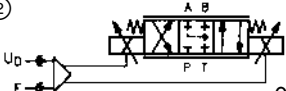
▶▶▶ sans régulation de position

Sinnbild Symbol Symbole	 V/VA max	Δp [bar]	$Q_{nom.}$ [l/min] Q_A Q_B	$P_{max.}$ [bar]		[kg]	Ⓔ
②  OBE $U_D = 24 V =$ $60 VA \text{ max}$ $U_{D-E} 0 \dots \pm 10 V$		5	35 35	P, A, B: 315 T: 250		8,3	0 811 404 852
01			65 65				0 811 404 850
②  OBE			35 35	0 811 404 853			
01 + L			65 65	0 811 404 851			
(4 x)  M 6 x 35 DIN 912-10.9							2 910 151 207
* 					KS	1 834 482 022	
Stecker 7-polig					KS	1 834 482 026	
Plug 7-pole					MS	1 834 482 023	
Connecteur 7 pôles					MS	1 834 482 024	
Seite					KS 90°	1 834 484 252	
Page 241							

Kenngrößen

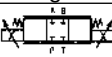
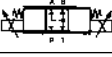
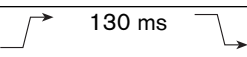
Allgemein		
Bauart	Schieberventil	
Betätigung	Proportionalmagnet ohne Lageregelung und mit eingebauter Elektronik	
Anschlussart	Plattenanschluss, Lochbild NG 10 (ISO 4401)	
Einbaulage	beliebig	
Umgebungstemperatur	-20 ... +50 °C	
Rüttelfestigkeit, Prüfbedingung	max. 25 g, Raumschüttelprüfung in allen Richtungen (24 h)	
Hydraulisch		
Druckmittel	Hydrauliköl nach DIN 51 524 ... 535, andere Medien nach Rückfrage	
Viskosität, empfohlen	20 ... 100 mm ² /s	
	max. zulässig 10 ... 800 mm ² /s	
Druckmitteltemperatur	-20 ... +70 °C	
Filterung	Zulässige Verschmutzungsstufe des Druckmittels nach NAS 1638	Zu erreichen mit Filter β _x = 75
	7	X = 5
	8	10
	9	15
Durchflussrichtung	siehe Sinnbild	
Max. Betriebsdruck (statisch)	Anschluss P, A, B: 315 bar Anschluss T: 250 bar	
Nenndurchfluss (bei Δp = 5 bar)*	35	65 l/min (pro Steuerkante)
	Q _A bei 8 V	28 ± 2 l/min
Einsatzgrenze	siehe Diagramm	
Lecköl/Steuerkante (Δp = 100 bar)		A → T = 80 cm ³ /min B → T = 80 cm ³ /min
Leckölentlastung (Δp = 5 bar)		A → T = 0,4 ... 0,8 l/min B → T = 0,4 ... 0,8 l/min
Statisch/Dynamisch		
Hysterese	≦ 8%	
Ansprechempfindlichkeit	≦ 5%	
Stellzeit 100% Signalsprung (Rampe = T _{min})	90 ms	 130 ms
Elektrische Kenngrößen	siehe Seite 230 (OBE)	

*** Nenndurchfluss**
Dieser bezieht sich immer auf eine Druckdifferenz an der Drosselstelle von Δp = 5 bar.
Der Durchfluss bei anderen Differenzdrücken berechnet sich nach:

$$Q_x = Q_{\text{nom.}} \cdot \sqrt{\frac{\Delta p_x}{5}}$$

Hierbei sind jedoch die **Einsatzgrenzen** zu beachten. Bei Überschreitung der Einsatzgrenzen treten Strömungskräfte auf, die zu unkontrollierbaren Schieberbewegungen führen. Durch die Verwendung von **Druckwaagen** wird Δp sicher begrenzt.



Characteristics

General

Construction	Spool type valve
Actuation	Proportional solenoid without position control and with on-board electronics
Connection type	Subplate, mounting hole configuration NG 10 (ISO 4401)
Mounting position	optional
Ambient temperature range	-20 ... +50 °C
Vibration resistance, test condition	max. 25 g, shaken in 3 dimensions (24 h)

Hydraulic

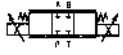
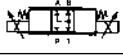
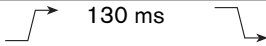
Pressure medium	Hydraulic oil as per DIN 51 524 ... 535, other fluids after prior consultation	
Viscosity, recommended	20 ... 100 mm ² /s	
max. permitted	10 ... 800 mm ² /s	
Pressure medium temperature	-20 ... +70 °C	
Filtration	Permissible contamination class of pressure medium as per NAS 1638	Achieved using filter β _x = 75
In line with operational reliability and service life	7	X = 5
	8	10
	9	15
Flow direction	cf. symbol	
Max. working pressure (static)	Ports P, A, B: 315 bar Port T: 250 bar	
Nominal flow (at Δp = 5 bar)*	35	65 l/min (per metering edge)
	Q _A at 8 V	28 ± 2 l/min
Operating limits	see diagram	
Leakage/Metering edge (Δp = 100 bar)		A → T = 80 cm ³ /min B → T = 80 cm ³ /min
Leakage drain (Δp = 5 bar)		A → T = 0.4 ... 0.8 l/min B → T = 0.4 ... 0.8 l/min
Static/Dynamic		
Hysteresis	≅ 8%	
Response sensitivity	≅ 5%	
Response time 100% signal change (Ramp = T _{min})	90 ms	 130 ms
Electrical characteristics	see page 230 (OBE)	

* Nominal flow

This is always based on a pressure differential of Δp = 5 bar at the throttle point.

Where other pressure differentials are involved, flow is calculated according to the following formula:

$$Q_x = Q_{\text{nom.}} \cdot \sqrt{\frac{\Delta p_x}{5}}$$

However, the **operating limits** must be borne in mind here.

When the operating limits are exceeded, the ensuing flow forces lead to uncontrollable spool movements.

To achieve effective limitation of Δp, use is made of **pressure compensators**.



Caractéristiques



Générales

Construction	Distributeur à tiroir
Commande	Aimant à action proportionnelle sans régulation de position avec amplificateur intégré
Raccordement	Embase selon plan de pose NG 10 (ISO 4401)
Position de montage	indifférente
Température ambiante	-20 ... +50 °C
Vibrations, condition du test	max. 25 g, 3 dimensions (24 h)

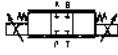
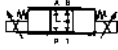
Hydrauliques

Fluide	Fluide hydraulique selon norme DIN 51 524 ... 535, autre fluide sur demande	
Viscosité, conseillée	20 ... 100 mm ² /s	
max. admissible	10 ... 800 mm ² /s	
Température du fluide	-20 ... +70 °C	
Filtration	Classe de pollution admissible du fluide selon NAS 1638	Avec un filtre β _x = 75
Selon sécurité de fonctionnement et durée de vie	7	X = 5
	8	10
	9	15
Sens d'écoulement	voir symbole	
Pression de service max. (statique)	Orifice P, A, B: 315 bar Orifice T: 250 bar	
Débit nominal (pour Δp = 5 bar)*	35	65 l/min (par arête de distribution)
	Q _A à 8 V	28 ±2l/min 58 ±3l/min
Limites d'utilisation	voir diagramme	
Fuites internes/Arête de distribution (Δp = 100 bar)		A → T = 80 cm ³ /min B → T = 80 cm ³ /min
Drainage de fuites internes (Δp = 5 bar)		A → T = 0,4 ... 0,8 l/min B → T = 0,4 ... 0,8 l/min

Statiques/Dynamiques

Hystérésis	≤ 8%
Seuil de réponse	≤ 5%
Temps de réponse pour une course de 100% (Rampe = T _{min})	90 ms  130 ms 
Caractéristiques électriques	voir page 230 (OBE)

*** Débit nominal**

Toujours par rapport à une différence de pression à l'étranglement de Δp = 5 bar.

Le débit pour d'autres différences de pression se calcule comme suit:

$$Q_x = Q_{nom.} \cdot \sqrt{\frac{\Delta p_x}{5}}$$

Il faut néanmoins tenir compte des

limites d'utilisation.

En cas de dépassement de ces plages d'utilisation, une pression trop élevée entraîne des déplacements de tiroir non contrôlés. L'utilisation de

balances de pression permet de

limiter en toute sécurité le Δp.

Kennlinien
Performance curves
Courbes caractéristiques
 $v = 35 \text{ mm}^2/\text{s}$

$Q_{\text{nom.}} = 35 \text{ l/min}$

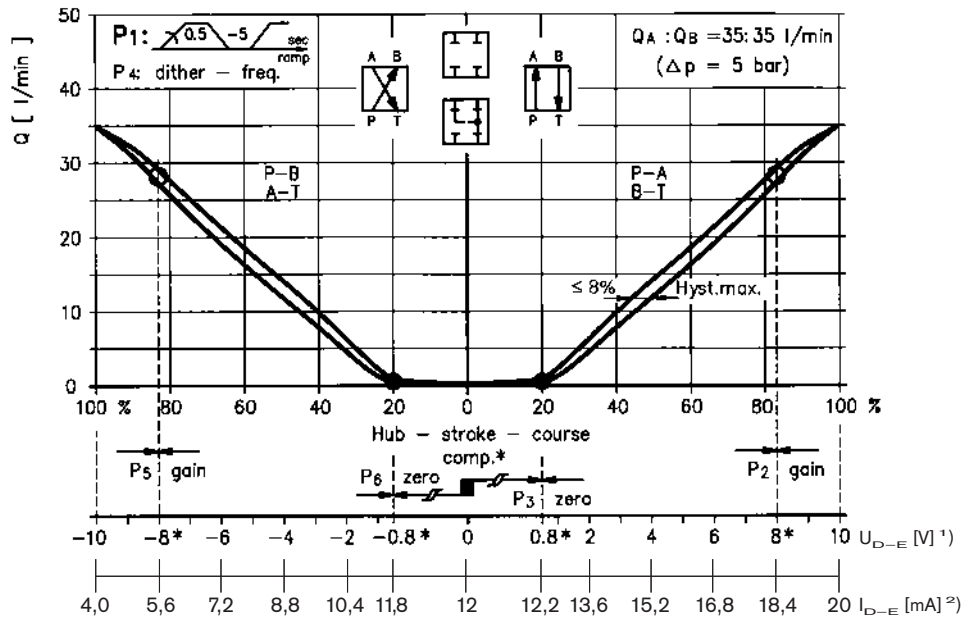

$Q_{\text{nom.}} = 65 \text{ l/min}$

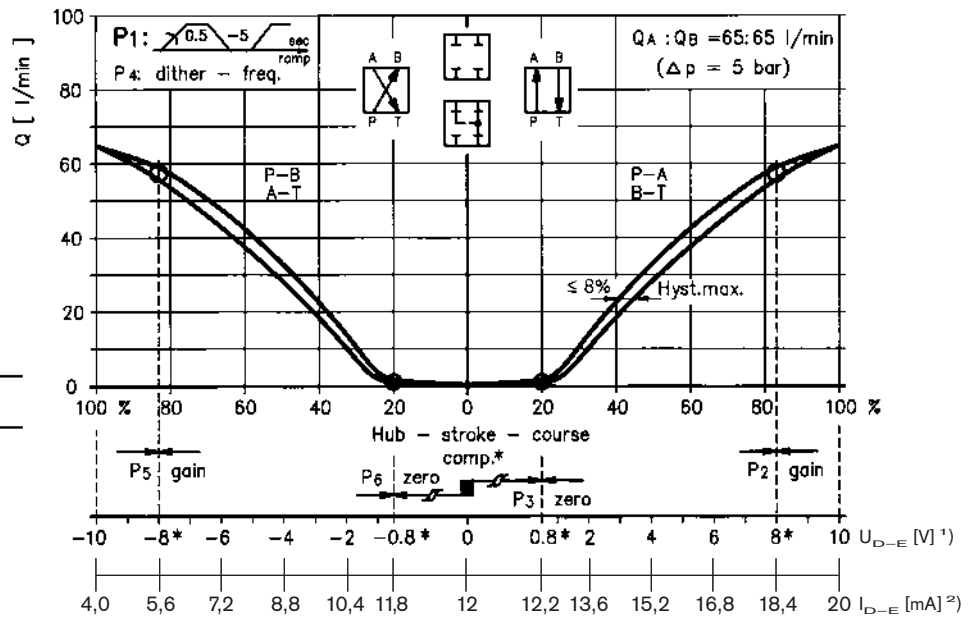

Hinweis/Remark/Note:

- P1 ramp
- P2 ... P6
- * Ab Werk eingestellt
- * Factory calibrated
- * Réglage par l'usine

7

▶ Elektronikabgleich
 siehe Seite 230
 1) Version: $U_E = 0 \dots +10 \text{ V}$
 2) Version: $I_E = 4 \dots 20 \text{ mA}$

▶▶ Electronics adjustment
 see page 230
 1) Version: $U_E = 0 \dots +10 \text{ V}$
 2) Version: $I_E = 4 \dots 20 \text{ mA}$

▶▶▶ Tarage de l'électronique
 voir page 230
 1) Version: $U_E = 0 \dots +10 \text{ V}$
 2) Version: $I_E = 4 \dots 20 \text{ mA}$

Einsatzgrenzen
Operating limits
Limites d'utilisation

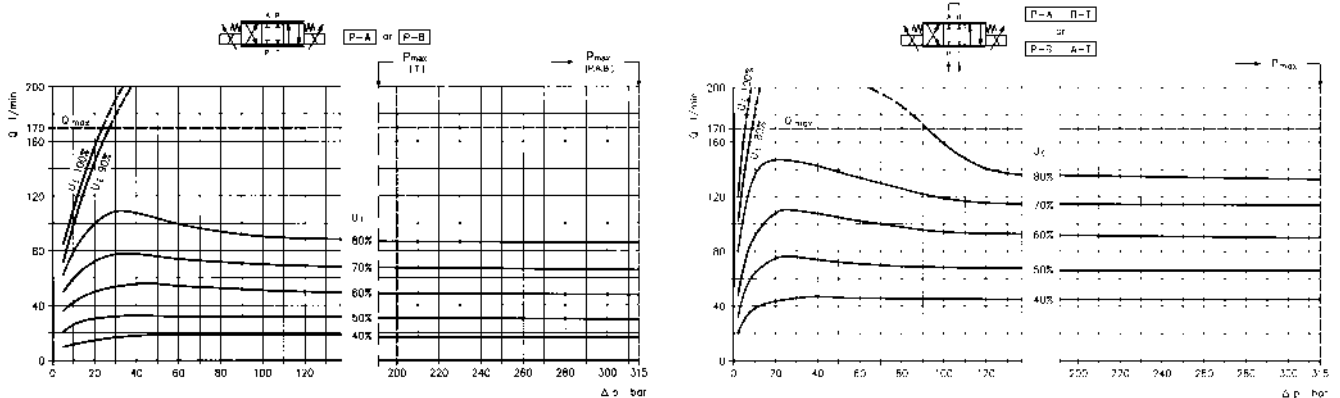

**Abmessungen
Dimensions
Cotes d'encombrement**

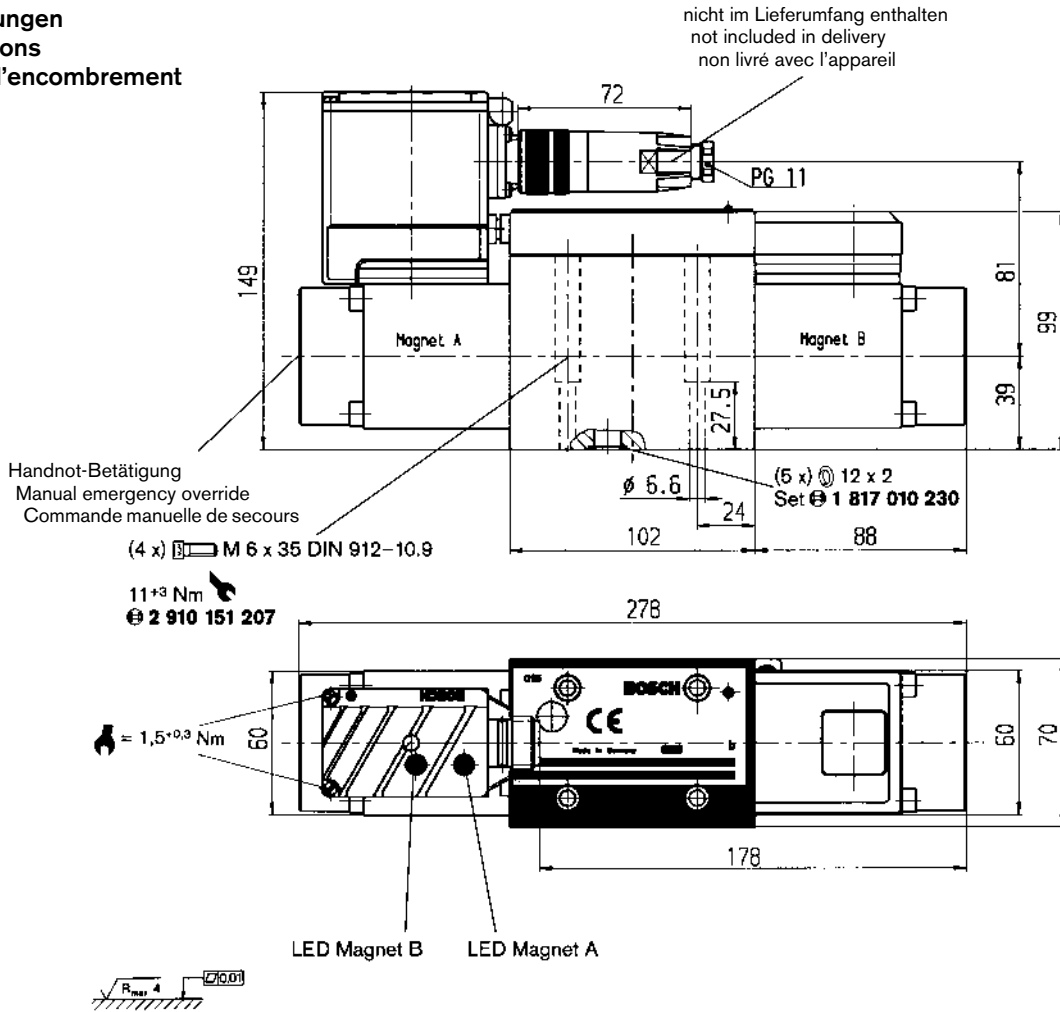

Abmessungen des Anschlusslochbildes NG 6 ISO 4401 siehe Seite 212

Dimensions of mounting hole configuration NG 6 ISO 4401 see page 212

Cotes du plan de pose NG 6 ISO 4401 voir page 212

Steckerbelegung ohne Lageregelung

Pin assignment without position control

Affectation du connecteur sans régulation de position

Version: $U_E = 0 \dots +10 \text{ V}$
 $R_i = 100 \text{ k}\Omega$

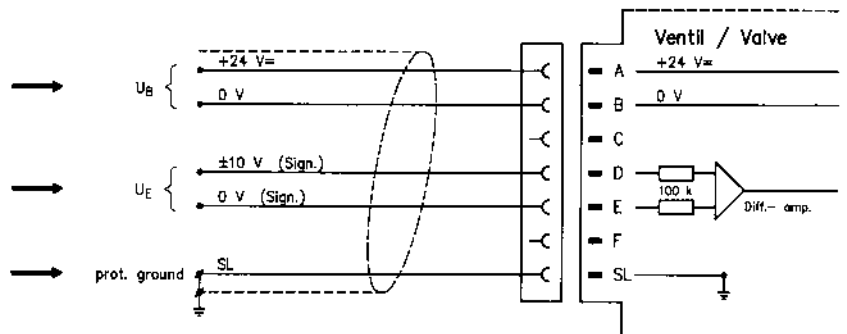

Version: $I_E = 4 \dots 12 \dots 20 \text{ mA}$

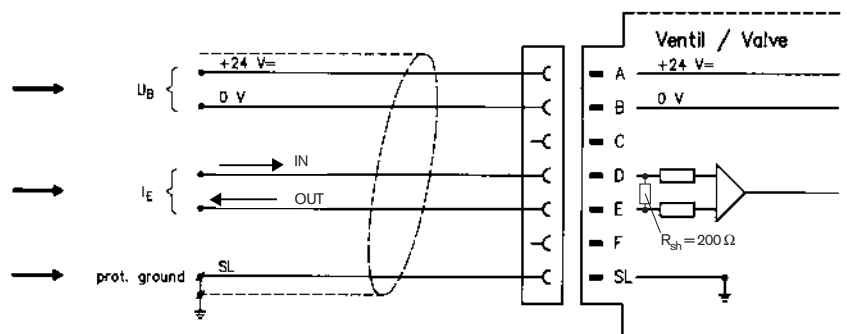

NG 10

Wegeventile Directional control valves Distributeurs

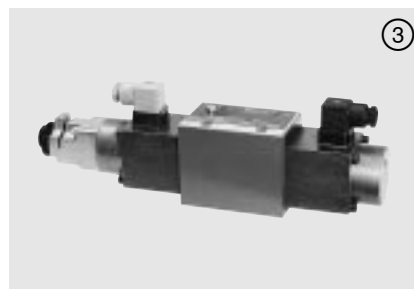

Funktion
Function
Fonction

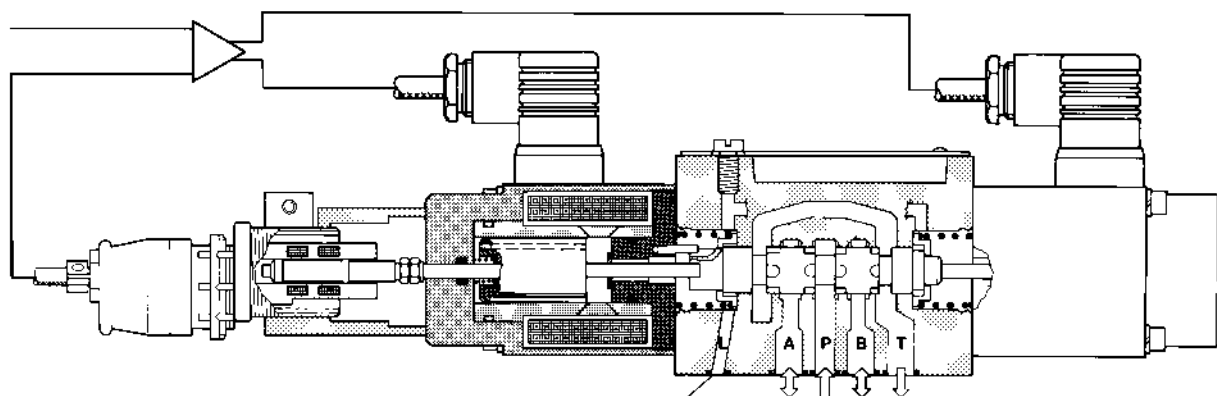





Zusätzlicher Leckölanschluss
Additional drain port
Drainage supplémentaire
 $p_{max.} \leq 2 \text{ bar}$

7

▶ mit Lageregelung

▶▶ with position control

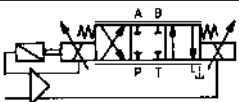
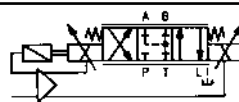
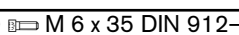
▶▶▶ avec régulation de position

Sinnbild Symbol Symbole	 A/VA max	Δp [bar]	$Q_{nom.}$ [l/min] Q_A Q_B		$p_{max.}$ [bar]	 [kg]	⊕	
③  01	3,7/60	5	32	32	P, A, B: 315 T: 250	2-K 3-K	8	0 811 404 003
③  01 + L			63	63				0 811 404 001
			63	36,5				0 811 404 086
(4 x)  M 6 x 35 DIN 912-10.9							2 910 151 207	
 K			WV 60 – RGC2		2-K	0,25	0 811 405 120	
			WV 60 – RGC4		3-K	0,3	0 811 405 138	
	Seite Page 266							

Kenngrößen

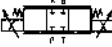
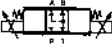
Allgemein			
Bauart	Schieberventil		
Betätigung	Proportionalmagnet mit Lageregelung		
Anschlussart	Plattenanschluss, Lochbild NG 10 (ISO 4401) + L		
Einbaulage	beliebig		
Umgebungstemperatur	-20 ... +50 °C		
Hydraulisch			
Druckmittel	Hydrauliköl nach DIN 51 524 ... 535, andere Medien nach Rückfrage		
Viskosität, empfohlen	20 ... 100 mm ² /s		
	max. zulässig 10 ... 800 mm ² /s		
Druckmitteltemperatur	-20 ... +80 °C		
Filterung	Zulässige Verschmutzungsstufe		Zu erreichen mit Filter
	des Druckmittels nach NAS 1638		β _x = 75
	8		X = 10
	9		20
Entsprechend Betriebssicherheit und Lebensdauer	10		25
	siehe Sinnbild		
Nenndurchfluss (bei Δp = 5 bar)*	32	63	63 : 36,5 l/min (pro Kanal)
Lecköl/Steuerkante (Δp = 100 bar)		A → T = 80 cm ³ /min	
		B → T = 80 cm ³ /min	
Leckölentlastung (Δp = 5 bar)		A → T = 0,4 ... 0,8 l/min	
		B → T = 0,4 ... 0,8 l/min	
Max. Betriebsdruck	Anschluss P, A, B: 315 bar		
	Anschluss T: 250 bar		
	Anschluss L: ≤ 2 bar		
Elektrisch			
Relative Einschaltdauer	100% ED		
Schutzart	IP 65 nach DIN 40 050 und IEC 14 434/5		
Anschluss Magnet	Gerätesteckdose DIN 43 650/ISO 4400		
Anschluss Wegaufnehmer	Spezialsteckdose		
Magnetstrom	max. 3,7 A		
Spulenwiderstand R ₂₀	2,5 Ω		
Max. Leistungsaufnahme bei 100% Last und Betriebstemperatur	60 VA max		
Statisch/Dynamisch			
Hysterese	≤ 0,75%		
Umkehrspanne	≤ 0,5%		
Exemplarstreuung	≈ 10%		
Stellzeit 100% Signalsprung	50 ms		
	10% Signalsprung 20 ms		

Alle Kenngrößen in Verbindung mit Proportionalverstärker: WV 60 – RGC 2

*** Nenndurchfluss**

Dieser bezieht sich immer auf eine Druckdifferenz an der Drosselstelle von Δp = 5 bar. Der Durchfluss bei anderen Differenzdrücken berechnet sich nach:

$$Q_x = Q_{nom.} \cdot \sqrt{\frac{\Delta p_x}{5}}$$

Hierbei sind jedoch die **Einsatzgrenzen** zu beachten. Bei Überschreitung der Einsatzgrenzen treten Strömungskräfte auf, die zu unkontrollierbaren Schieberbewegungen führen. Durch die Verwendung von **Druckwaagen** wird Δp sicher begrenzt.



Characteristics

General

Construction	Spool type valve
Actuation	Proportional solenoid with position control
Connection type	Subplate, mounting hole configuration NG 10 (ISO 4401) + L
Mounting position	optional
Ambient temperature range	-20 ... +50 °C

Hydraulic

Pressure medium	Hydraulic oil as per DIN 51 524 ... 535, other fluids after prior consultation		
Viscosity, recommended max. permitted	20 ... 100 mm ² /s		
	10 ... 800 mm ² /s		
Pressure medium temperature	-20 ... +80 °C		
Filtration	Permissible contamination class of pressure medium as per NAS 1638	Achieved using filter β _x = 75	
In line with operational reliability and service life	8	X = 10	
	9	20	
	10	25	
Flow direction	cf. symbol		
Nominal flow (at Δp = 5 bar)*	32	63	63 : 36.5 l/min (per channel)
Leakage/Metering edge (Δp = 100 bar)		A → T = 80 cm ³ /min B → T = 80 cm ³ /min	
Leakage drain (Δp = 5 bar)		A → T = 0.4 ... 0.8 l/min B → T = 0.4 ... 0.8 l/min	
Max. working pressure	Ports P, A, B: 315 bar Port T: 250 bar Port L: ≤ 2 bar		

Electrical

Cyclic duration factor	100%
Degree of protection	IP 65 as per DIN 40 050 and IEC 14 434/5
Solenoid connector	Connector DIN 43 650/ISO 4400
Position transducer connector	Special connector
Solenoid current	max. 3.7 A
Coil resistance R ₂₀	2.5 Ω
Max. power consumption at 100% load and operational temperature	60 VA max

Static/Dynamic

Hysteresis	≤ 0.75%
Range of inversion	≤ 0.5%
Manufacturing tolerance	≈ 10%
Response time 100% signal change 10% signal change	50 ms
	20 ms

All characteristic values in connection with proportional amplifier: WV 60 – RGC 2

* Nominal flow

This is always based on a pressure differential of Δp = 5 bar at the throttle point.

Where other pressure differentials are involved, flow is calculated according to the following formula:

$$Q_x = Q_{\text{nom.}} \cdot \sqrt{\frac{\Delta p_x}{5}}$$

However, the **operating limits** must be borne in mind here.

When the operating limits are exceeded, the ensuing flow forces lead to uncontrollable spool movements.

To achieve effective limitation of Δp, use is made of **pressure compensators**.



Caractéristiques

Générales

Construction	Distributeur à tiroir
Commande	Aimant à action proportionnelle avec régulation de position
Raccordement	Embase selon plan de pose NG 10 (ISO 4401) + L
Position de montage	indifférente
Température ambiante	-20 ... +50 °C

Hydrauliques

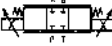
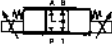
Fluide	Fluide hydraulique selon norme DIN 51 524 ... 535, autre fluide sur demande		
Viscosité, conseillée max. admissible	20 ... 100 mm ² /s		
	10 ... 800 mm ² /s		
Température du fluide	-20 ... +80 °C		
Selon sécurité de fonctionnement et durée de vie	Filtration	Classe de pollution admissible du fluide selon NAS 1638	Avec un filtre β _x = 75
		8	X = 10
		9	20
		10	25
Sens d'écoulement	voir symbole		
Débit nominal (pour Δp = 5 bar)*	32	63	63 : 36,5 l/min (par canal)
Fuites internes/Arête de distribution (Δp = 100 bar)		A → T = 80 cm ³ /min B → T = 80 cm ³ /min	
Drainage de fuites internes (Δp = 5 bar)		A → T = 0,4 ... 0,8 l/min B → T = 0,4 ... 0,8 l/min	
Pression de service max.	Orifice P, A, B: 315 bar Orifice T: 250 bar Orifice L: ≅ 2 bar		

Electriques

Facteur de marche réelle	FM 100%
Degré de protection	IP 65 selon norme DIN 40 050 et IEC 14 434/5
Branchement électro-aimant	par prise selon norme DIN 43 650/ISO 4400
Branchement du capteur de position	Prise spéciale
Courant d'alimentation de l'électro-aimant	max. 3,7 A
Résistance de la bobine R ₂₀	2,5 Ω
Consommation max. pour charge 100% et température de service	60 VA max

Statiques/Dynamiques

Hystérésis	≅ 0,75%
Seuil d'inversion	≅ 0,5%
Dispersion	≈ 10%
Temps de réponse pour une course	de 100%
	de 10%
	50 ms
	20 ms

Toute caractéristique en liaison avec l'amplificateur électronique proportionnel: WV 60 – RGC 2

*** Débit nominal**

Toujours par rapport à une différence de pression à l'étranglement de Δp = 5 bar.
Le débit pour d'autres différences de pression se calcule comme suit:

$$Q_x = Q_{nom.} \cdot \sqrt{\frac{\Delta p_x}{5}}$$

Il faut néanmoins tenir compte des **limites d'utilisation**.
En cas de dépassement de ces plages d'utilisation, une pression trop élevée entraîne des déplacements de tiroir non contrôlés. L'utilisation de **balances de pression** permet de limiter en toute sécurité le Δp.

Kennlinien
Performance curves
Courbes caractéristiques
 $v = 35 \text{ mm}^2/\text{s}$

$Q_{\text{nom.}} = 32 \text{ l/min}$
 Symb. 01 und/and/et 01 + L

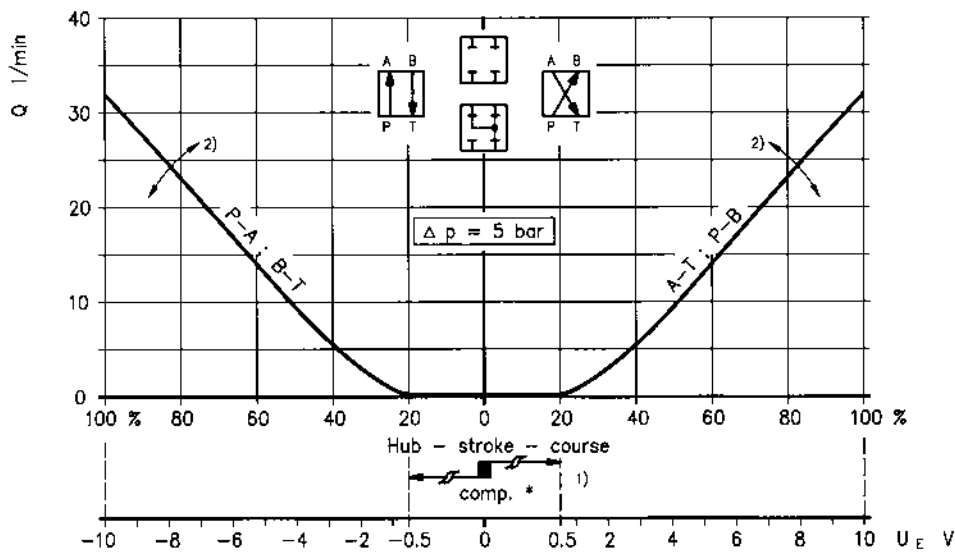

$Q_{\text{nom.}} = 63 \text{ l/min}$
 Symb. 01 und/and/et 01 + L

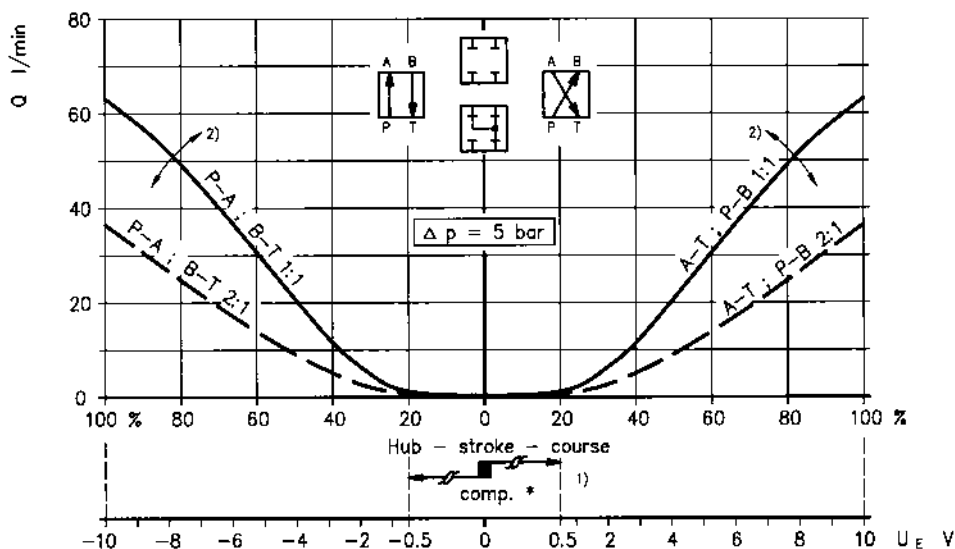

7

► **Ventilverstärker**
 1) Nullpunkt-Justierung → ±0,5 V
 2) Empfindlichkeits-Justierung

►► **Valve amplifier**
 1) Zero adjustment → ±0.5 V
 2) Gain adjustment

►►► **Amplificateur de valve**
 1) Tarage du zéro → ±0,5 V
 2) Tarage du gain

Einsatzgrenzen
Operating limits
Limites d'utilisation

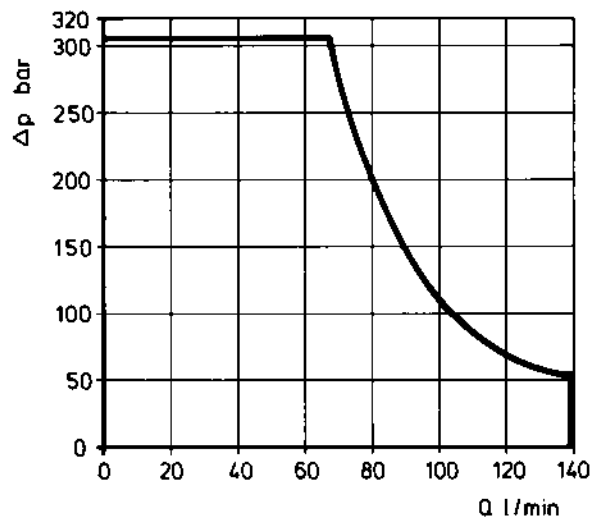

**Abmessungen
Dimensions
Cotes d'encombrement**

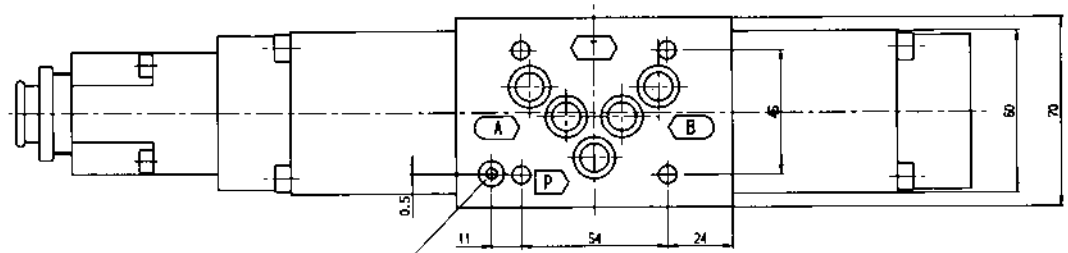

(1 x) \varnothing 6 x 2

1834484040

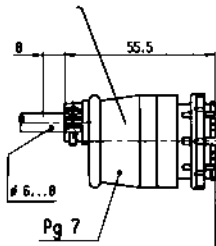

(4 x) \square M 6x35 DIN 912-10.9

11⁺³ Nm
2910151207

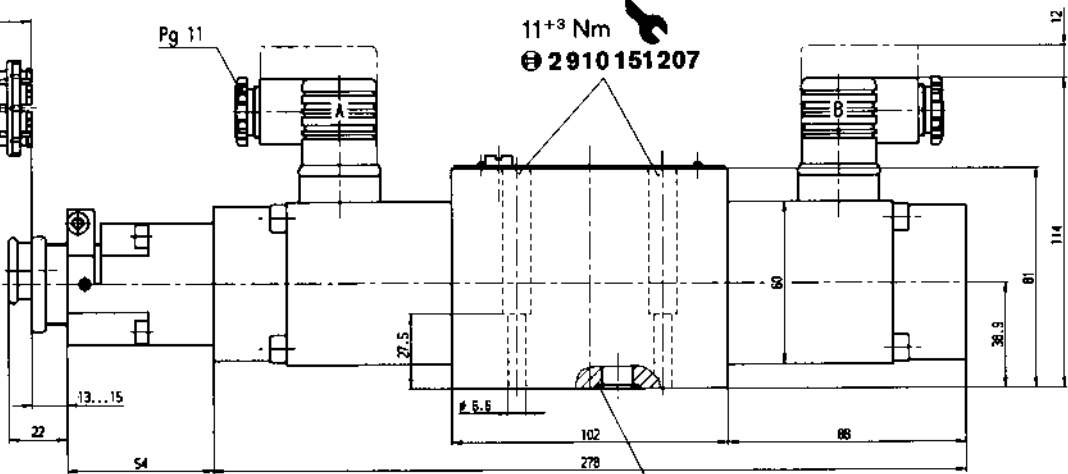

(5 x) \varnothing 12 x 2

\varnothing Set **1817010230**

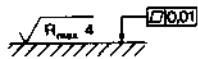

► Abmessungen des Anschlusslochbildes NG 10 ISO 4401 (Zusätzlicher L-Anschluss) siehe Seite 212

►► Dimensions of mounting hole configuration NG 10 ISO 4401 (Additional port L) see page 212

►►► Cotes du plan de pose NG 10 ISO 4401 (Orifice L supplémentaire) voir page 212

NG 10

Wegeventile mit OBE

Directional control valves with OBE

Distributeurs avec OBE

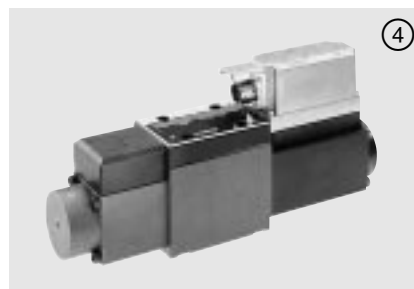

Funktion
Function
Fonction

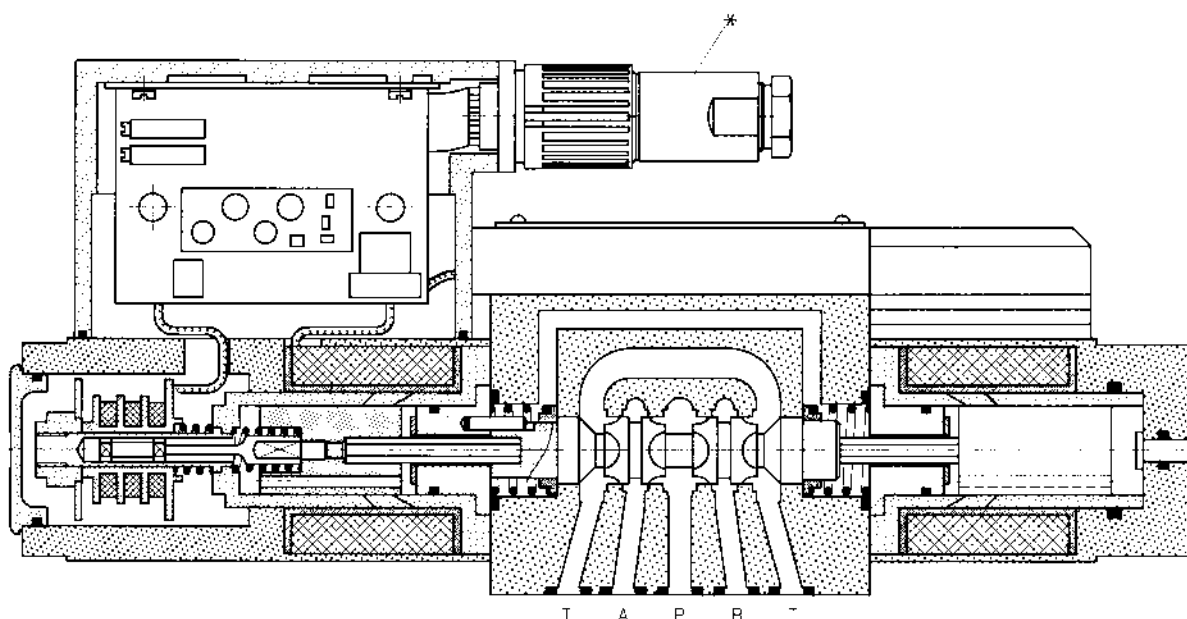
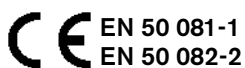







7

▶ mit Lageregelung

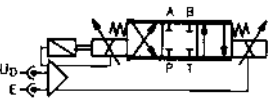
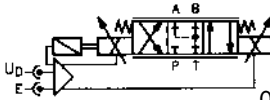
▶▶ with position control

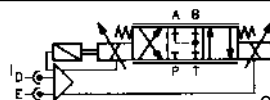
▶▶▶ avec régulation de position

Sinnbild Symbol Symbole		Δp [bar]	$Q_{nom.}$ [l/min]	$p_{max.}$ [bar]		\oplus	
④  OBE 01	V/VA max 24 V= 60 VA max $U_{D-E} 0 \dots \pm 10 V$	5	Q_A 50	Q_B 50	P, A, B: 315 T: 200	8,3	0 811 404 770
			80	80			0 811 404 771
			80	50			0 811 404 774
④  OBE 01 + L			50	50			0 811 404 772
			80	80			0 811 404 773
			80	50			0 811 404 777
④  OBE 01 + L	24 V= 60 VA max $I = 4 \dots 20 mA$		50	50			0 811 404 778
(4 x)  M 6 x 40 DIN 912-10.9							2 910 151 209
* 		Stecker 7-polig		KS		1 834 482 022	
		Plug 7-pole		KS		1 834 482 026	
		Connecteur 7 pôles		MS		1 834 482 023	
		Seite		MS		1 834 482 024	
		Page 241		KS 90°		1 834 484 252	

Kenngrößen

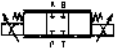
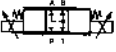
Allgemein		
Bauart	Schieberventil, ohne Stahlhülse	
Betätigung	Proportionalmagnet mit Lageregelung und mit eingebauter Elektronik	
Anschlussart	Plattenanschluss, Lochbild NG 10 (ISO 4401)	
Einbaulage	beliebig	
Umgebungstemperatur	-20 ... +50 °C	
Rüttelfestigkeit, Prüfbedingung	max. 25 g, Raumschüttelprüfung in allen Richtungen (24 h)	
Hydraulisch		
Druckmittel	Hydrauliköl nach DIN 51 524 ... 535, andere Medien nach Rückfrage	
Viskosität, empfohlen max. zulässig	20 ... 100 mm ² /s	
	10 ... 800 mm ² /s	
Druckmitteltemperatur	-20 ... +70 °C	
Entsprechend Betriebssicherheit und Lebensdauer	Zulässige Verschmutzungsstufe des Druckmittels nach NAS 1638	Zu erreichen mit Filter β _x = 75
	7	X = 5
	8	10
	9	15
Durchflussrichtung	siehe Sinnbild	
Max. Betriebsdruck (statisch)	Anschluss P, A, B: 315 bar Anschluss T: 200 bar	
Nenndurchfluss (bei Δp = 5 bar)*	50	80 l/min (pro Steuerkante)
	Q _A bei 8 V	35 ±3% 70 ±3%
Einsatzgrenze	siehe Diagramm	
Lecköl/Steuerkante (Δp = 100 bar)		A → T = 80 cm ³ /min
		B → T = 80 cm ³ /min
Leckölentlastung (Δp = 5 bar)		A → T = 0,4 ... 0,8 l/min
		B → T = 0,4 ... 0,8 l/min
Statisch/Dynamisch		
Hysterese	< 0,3%	
Umkehrspanne	< 0,2%	
Exemplarstreuung	≤ ±3%	
Stellzeit 100% Signalsprung	40 ms	
	10% Signalsprung	
Temperaturdrift	< 1% bei ΔT = 40 °C	
Elektrische Kenngrößen	siehe Seite 223 (OBE)	

*** Nenndurchfluss**

Dieser bezieht sich immer auf eine Druckdifferenz an der Drosselstelle von Δp = 5 bar. Der Durchfluss bei anderen Differenzdrücken berechnet sich nach:

$$Q_x = Q_{nom.} \cdot \sqrt{\frac{\Delta p_x}{5}}$$

Hierbei sind jedoch die **Einsatzgrenzen** zu beachten. Bei Überschreitung der Einsatzgrenzen treten Strömungskräfte auf, die zu unkontrollierbaren Schieberbewegungen führen. Durch die Verwendung von **Druckwaagen** wird Δp sicher begrenzt.



Characteristics

General

Construction	Spool type valve, without steel sleeve
Actuation	Proportional solenoid with position control and with on-board electronics
Connection type	Subplate, mounting hole configuration NG 10 (ISO 4401)
Mounting position	optional
Ambient temperature range	-20 ... +50 °C
Vibration resistance, test condition	max. 25 g, shaken in 3 dimensions (24 h)

Hydraulic

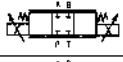
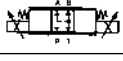
Pressure medium	Hydraulic oil as per DIN 51 524 ... 535, other fluids after prior consultation	
Viscosity, recommended	20 ... 100 mm ² /s	
max. permitted	10 ... 800 mm ² /s	
Pressure medium temperature	-20 ... +70 °C	
Filtration	Permissible contamination class of pressure medium as per NAS 1638	Achieved using filter $\beta_x = 75$
In line with operational reliability and service life	7	X = 5
	8	10
	9	15
Flow direction	cf. symbol	
Max. working pressure (static)	Ports P, A, B: 315 bar Port T: 200 bar	
Nominal flow (at $\Delta p = 5$ bar)*	50	80 l/min (per metering edge)
	Q_A at 8 V	35 ±3% 70 ±3%
Operating limits	see diagram	
Leakage/Metering edge ($\Delta p = 100$ bar)		A → T = 80 cm ³ /min B → T = 80 cm ³ /min
Leakage drain ($\Delta p = 5$ bar)		A → T = 0.4 ... 0.8 l/min B → T = 0.4 ... 0.8 l/min
Static/Dynamic		
Hysteresis	< 0.3%	
Range of inversion	< 0.2%	
Manufacturing tolerance	≅ ±3%	
Response time 100% signal change	40 ms	
	10% signal change	
Thermal drift	< 1%, at $\Delta T = 40$ °C	
Electrical characteristics	see page 223 (OBE)	

* Nominal flow

This is always based on a pressure differential of $\Delta p = 5$ bar at the throttle point.

Where other pressure differentials are involved, flow is calculated according to the following formula:

$$Q_x = Q_{\text{nom.}} \cdot \sqrt{\frac{\Delta p_x}{5}}$$

However, the **operating limits** must be borne in mind here.

When the operating limits are exceeded, the ensuing flow forces lead to uncontrollable spool movements.

To achieve effective limitation of Δp , use is made of **pressure compensators**.



Caractéristiques

Générales

Construction	Distributeur à tiroir, sans fourreau en acier
Commande	Aimant à action proportionnelle avec régulation de position avec amplificateur intégré
Raccordement	Embase selon plan de pose NG 10 (ISO 4401)
Position de montage	indifférente
Température ambiante	-20 ... +50 °C
Vibrations, condition du test	max. 25 g, 3 dimensions (24 h)

Hydrauliques

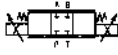
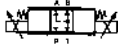
Fluide	Fluide hydraulique selon norme DIN 51 524 ... 535, autre fluide sur demande	
Viscosité, conseillée max. admissible	20 ... 100 mm ² /s	
	10 ... 800 mm ² /s	
Température du fluide	-20 ... +70 °C	
Filtration	Classe de pollution admissible du fluide selon NAS 1638	Avec un filtre β _x = 75
	7	X = 5
	8	10
	9	15
Selon sécurité de fonctionnement et durée de vie		
Sens d'écoulement	voir symbole	
Pression de service max. (statique)	Orifice P, A, B: 315 bar Orifice T: 200 bar	
Débit nominal (pour Δp = 5 bar)* Q _A à 8 V	50	80 l/min (par arête de distribution)
	35 ±3%	70 ±3%
Limites d'utilisation	voir diagramme	
Fuites internes/Arête de distribution (Δp = 100 bar)		A → T = 80 cm ³ /min B → T = 80 cm ³ /min
Drainage de fuites internes (Δp = 5 bar)		A → T = 0,4 ... 0,8 l/min B → T = 0,4 ... 0,8 l/min

Statiques/Dynamiques

Hystérésis	< 0,3%
Seuil d'inversion	< 0,2%
Dispersion	≅ ±3%
Temps de réponse pour une course de 100%	40 ms
	de 10%
Dérive en température	< 1% pour ΔT = 40 °C
Caractéristiques électriques	voir page 223 (OBE)

*** Débit nominal**

Toujours par rapport à une différence de pression à l'étranglement de Δp = 5 bar.
Le débit pour d'autres différences de pression se calcule comme suit:

$$Q_x = Q_{nom.} \cdot \sqrt{\frac{\Delta p_x}{5}}$$

Il faut néanmoins tenir compte des **limites d'utilisation.**

En cas de dépassement de ces plages d'utilisation, une pression trop élevée entraîne des déplacements de tiroir non contrôlés. L'utilisation de **balances de pression** permet de limiter en toute sécurité le Δp.

Kennlinien

Performance curves

Courbes caractéristiques

$v = 35 \text{ mm}^2/\text{s}$

$Q_{\text{nom.}} = 50 \text{ l/min}$

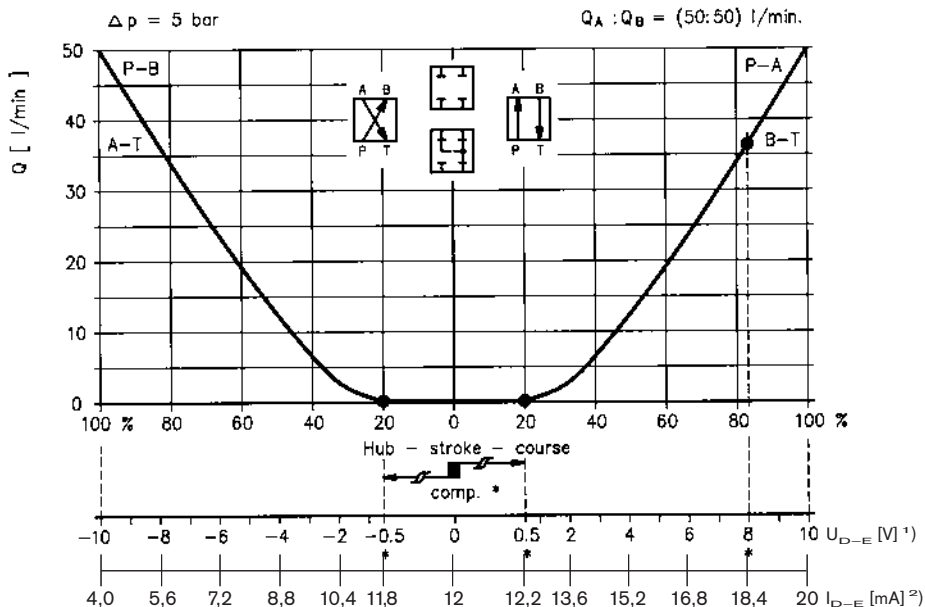

$Q_{\text{nom.}} = 80 \text{ l/min}$

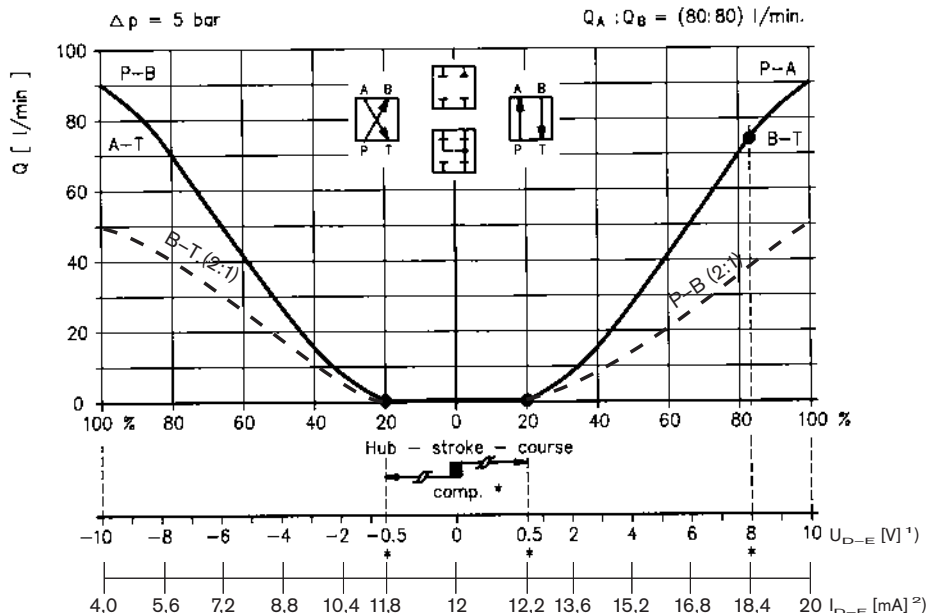

7

- ▶ * WerkEinstellung $\leq \pm 3\%$
- 1) Version: $U_E = 0 \dots +10 \text{ V}$
- 2) Version: $I_E = 4 \dots 20 \text{ mA}$

- ▶▶ * Factory setting $\leq \pm 3\%$
- 1) Version: $U_E = 0 \dots +10 \text{ V}$
- 2) Version: $I_E = 4 \dots 20 \text{ mA}$

- ▶▶▶ * Réglage par l'usine $\leq \pm 3\%$
- 1) Version: $U_E = 0 \dots +10 \text{ V}$
- 2) Version: $I_E = 4 \dots 20 \text{ mA}$

Einsatzgrenzen

Operating limits

Limites d'utilisation

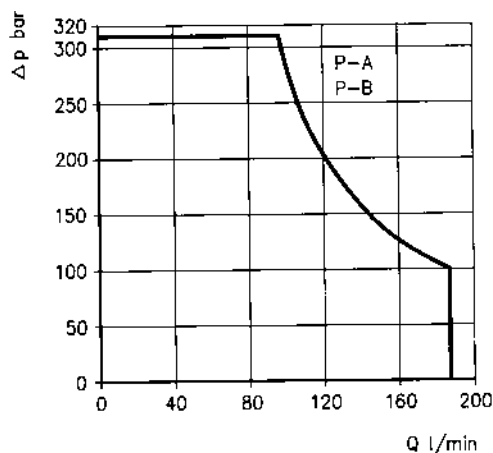

**Abmessungen
Dimensions
Cotes d'encombrement**

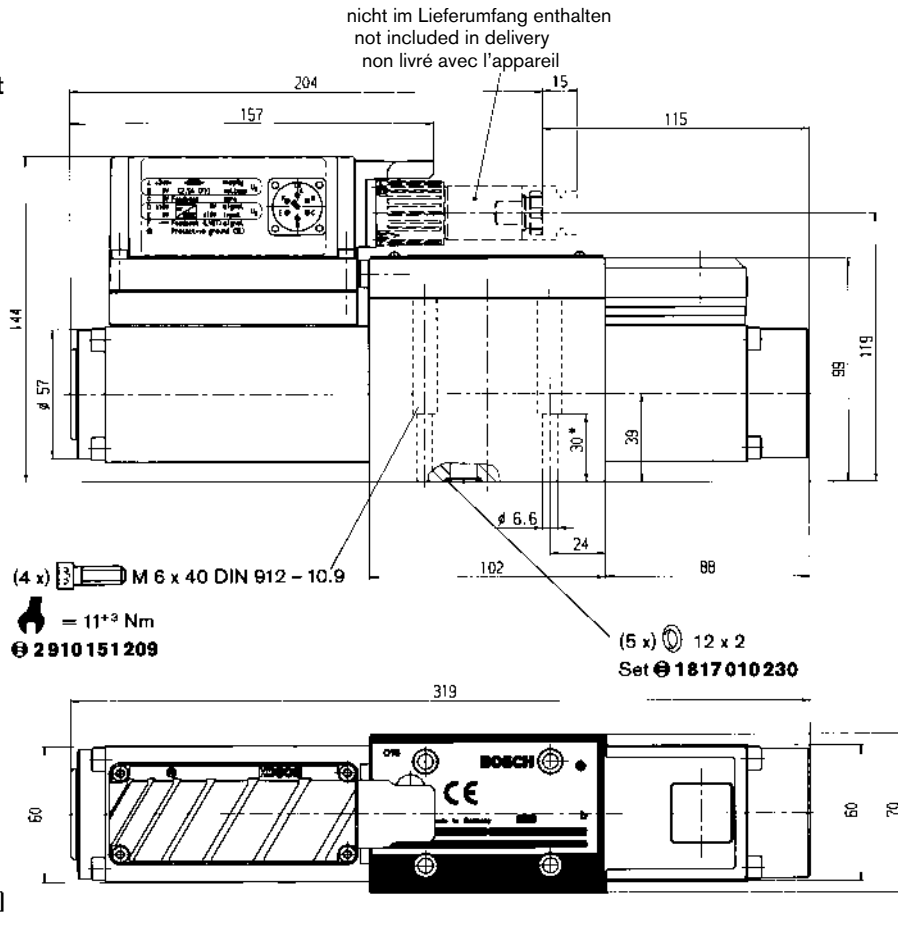

▶ Abmessungen des Anschlusslochbildes NG 6 ISO 4401 siehe Seite 212

▶▶ Dimensions of mounting hole configuration NG 6 ISO 4401 see page 212

▶▶▶ Cotes du plan de pose NG 6 ISO 4401 voir page 212

Steckerbelegung mit Lageregung

Pin assignment with position control

Affectation du connecteur avec régulation de position

Version: $U_E = 0 \dots +10 \text{ V}$
 $R_i = 100 \text{ k}\Omega$

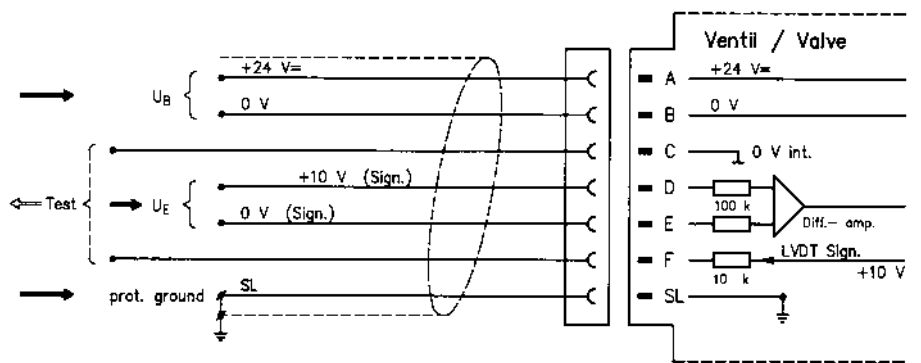

Version: $I_E = 4 \dots 12 \dots 20 \text{ mA}$

