

Relief valves

- Subplate mounted
- Pilot operated
- NG 10 and NG 25

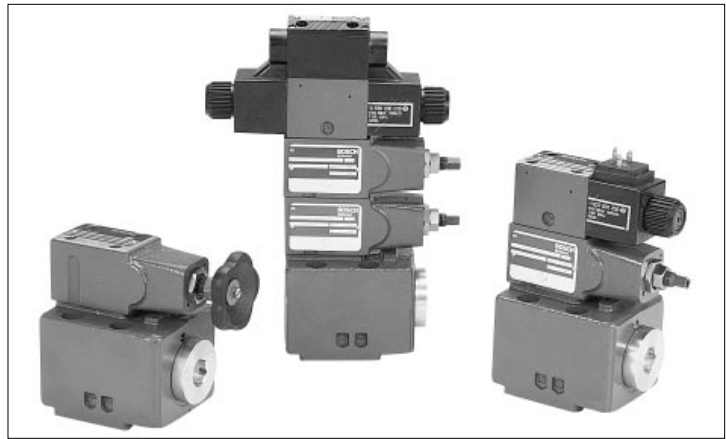

Specifications	
Mounting type	Subplate NG 10 or NG 25
Mounting position	Not restricted
Ambient temperature	-13... 122°F (-25... 50°C)
Fluid	Mineral-oil or fluid HFA / B / C / D
Viscosity	60... 2500 SUS (10...500 cst)
Fluid-temperature	-13 to 176°F (-25 to 80°C)
Filtration	Contamination class 10, according to NAS 1638 can be realized with filter $\beta_{25} = 75$
Seals	Viton
Direction of flow	As shown on symbol
Operating pressure	max. 4570 psi (315 bar)
Flow	NG 10: max 80 gpm (300 l/min) NG 25: max 100 gpm (400 l/min)

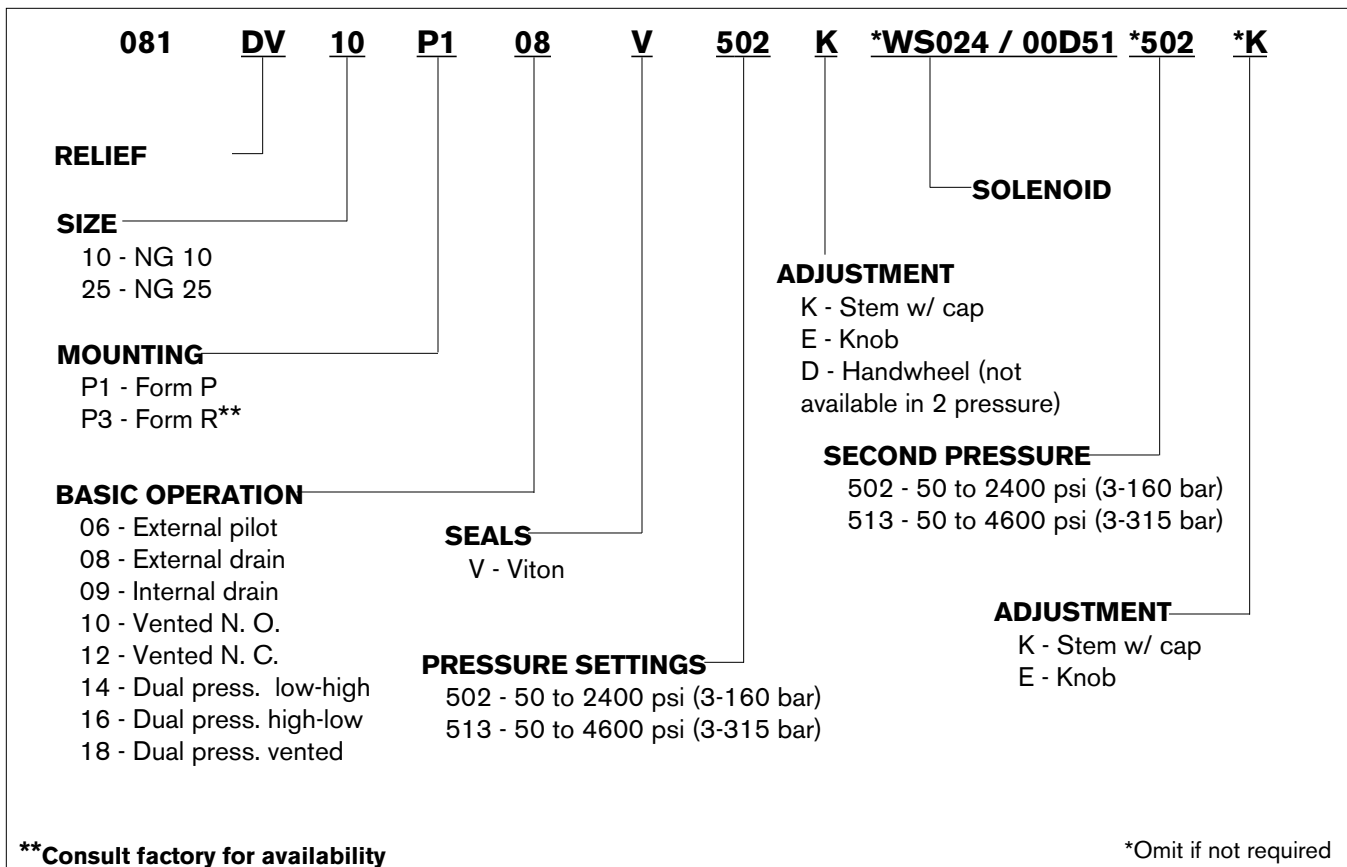

Performance characteristics

$v = 35 \text{ mm}^2/\text{s}$

Pressure relief valves

Symb. 08, 09, 10, 12, 14, 16, 18

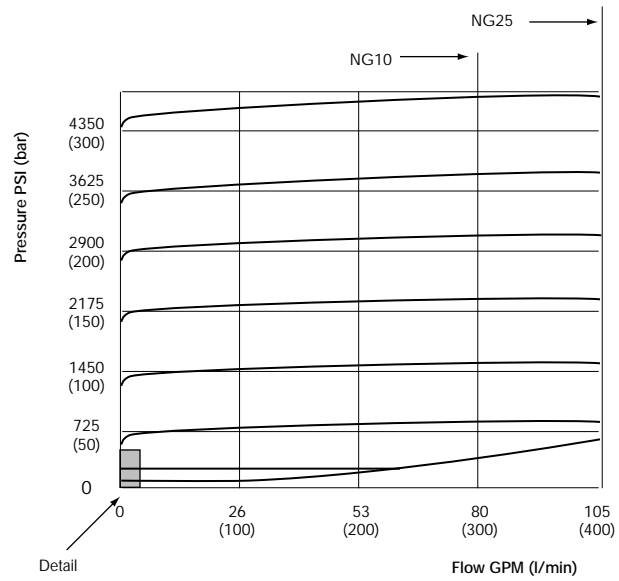
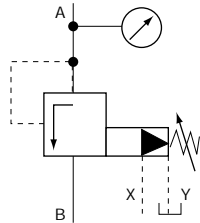

Detail

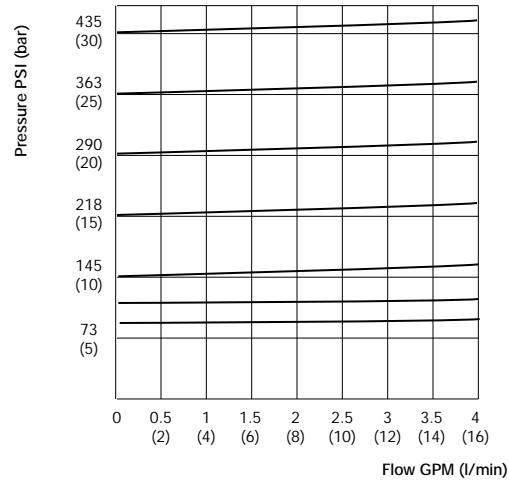

Control oil flow

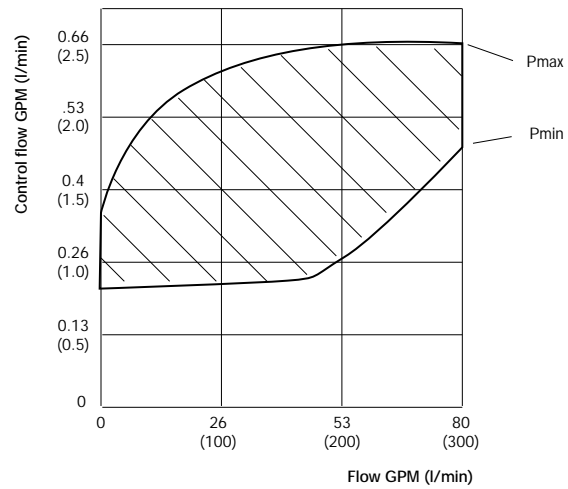

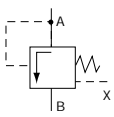
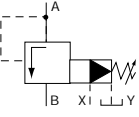
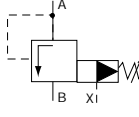
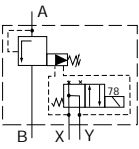
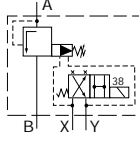
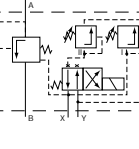
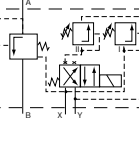
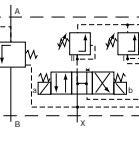
Symbol	Code	PSI (bar)	WS V / Hz	Lbs. (kg)	⊕ NG 10	Lbs. (kg)	⊕ NG 25			
	513	100... 4570 (7... 315)	-	16 (7)	9 811 230 038	17 (7.5)	9 811 230 138			
	502	44... 2300 (3... 160)								
	513	100... 4570 (7... 315)	D	18 (8)	9 811 230 001	19 (8.5)	9 811 230 101			
	502	44... 2300 (3... 160)	D		9 811 230 002		9 811 230 102			
	513	100... 4570 (7... 315)	K		9 811 230 003		9 811 230 103			
	502	44... 2300 (3... 160)	K		9 811 230 004		9 811 230 104			
	513	100... 4570 (7... 315)	D	18 (8)	9 811 230 005	19 (8.5)	9 811 230 105			
	502	44... 2300 (3... 160)	D		9 811 230 006		9 811 230 106			
	513	100... 4570 (7... 315)	K		9 811 230 007		9 811 230 107			
	502	44... 2300 (3... 160)	K		9 811 230 008		9 811 230 108			
	513	100... 4570 (7... 315)	K	024/00	22 (10)		9 811 230 009	9 811 230 109		
	513	100... 4570 (7... 315)	K	115/60			9 811 230 010	9 811 230 110		
	502	44... 2300 (3... 160)	K	024/00			9 811 230 011	9 811 230 111		
	502	44... 2300 (3... 160)	K	115/60			9 811 230 012	9 811 230 112		
	513	100... 4570 (7... 315)	E	024/00			9 811 230 013	9 811 230 113		
	513	100... 4570 (7... 315)	E	115/60			9 811 230 014	9 811 230 114		
	502	44... 2300 (3... 160)	E	024/00			9 811 230 015	9 811 230 115		
	502	44... 2300 (3... 160)	E	115/60			9 811 230 016	9 811 230 116		
	513	100... 4570 (7... 315)	K	024/00	22 (10)		9 811 230 017	23 (10.5)	9 811 230 117	
	513	100... 4570 (7... 315)	K	115/60			9 811 230 018		9 811 230 118	
	502	44... 2300 (3... 160)	K	024/00			9 811 230 019		9 811 230 119	
	502	44... 2300 (3... 160)	K	115/60			9 811 230 020		9 811 230 120	
	513	100... 4570 (7... 315)	E	024/00			9 811 230 021		9 811 230 121	
	513	100... 4570 (7... 315)	E	115/60			9 811 230 022		9 811 230 122	
	502	44... 2300 (3... 160)	E	024/00			9 811 230 023		9 811 230 123	
	502	44... 2300 (3... 160)	E	115/60			9 811 230 024		9 811 230 124	
	I	513	100... 4570 (7... 315)	K	024/00	24 (11)		25 (11.5)	9 811 230 025	9 811 230 125
	II	502	44... 2300 (3... 160)	K					9 811 230 026	
	I	513	100... 4570 (7... 315)	E	024/00					
	II	502	44... 2300 (3... 160)	E					9 811 230 027	
	I	513	100... 4570 (7... 315)	K	115/60					
	II	502	44... 2300 (3... 160)	K					9 811 230 028	
	I	513	100... 4570 (7... 315)	E	115/60					
	II	502	44... 2300 (3... 160)	E						
	I	513	100... 4570 (7... 315)	K	024/00			25 (11.5)	9 811 230 029	9 811 230 129
	II	502	44... 2300 (3... 160)	K					9 811 230 030	
	I	513	100... 4570 (7... 315)	E	024/00					
	II	502	44... 2300 (3... 160)	E					9 811 230 031	
	I	513	100... 4570 (7... 315)	K	115/60					
	II	502	44... 2300 (3... 160)	K					9 811 230 032	
	I	513	100... 4570 (7... 315)	E	115/60					
	II	502	44... 2300 (3... 160)	E						
	I	513	100... 4570 (7... 315)	K	024/00	26 (12)		28 (12.5)	9 811 230 033	9 811 230 133
	II	502	44... 2300 (3... 160)	K					9 811 230 034	
	I	513	100... 4570 (7... 315)	E	024/00					
	II	502	44... 2300 (3... 160)	E					9 811 230 035	
	I	513	100... 4570 (7... 315)	K	115/60					
	II	502	44... 2300 (3... 160)	K					9 811 230 036	
	I	513	100... 4570 (7... 315)	E	115/60					
	II	502	44... 2300 (3... 160)	E						

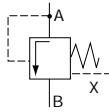
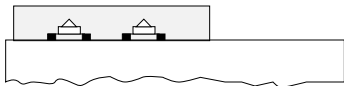
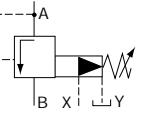
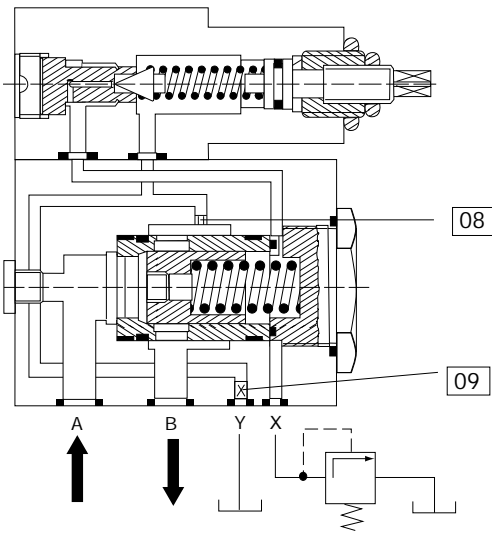
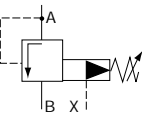

Pressure relief valve

<p>06</p> 	<p>Without pilot valve. remote control via port X</p>	<p>06</p> 
<p>08</p> 	<p>Control oil drain external (Y)</p>	<p>08 09</p> 
<p>09</p> 	<p>Control oil drain internal (B)</p>	

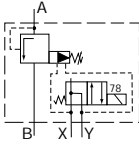
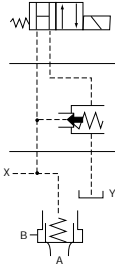
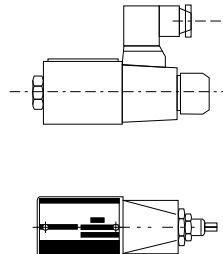
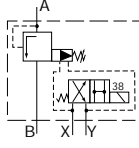
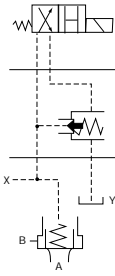
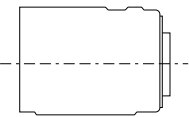
Pressure relief valve with electrical unloading

<p>10</p> 	<p>Normally vented</p>		
<p>12</p> 	<p>Normally at pressure</p>		

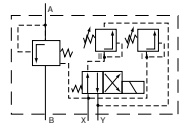
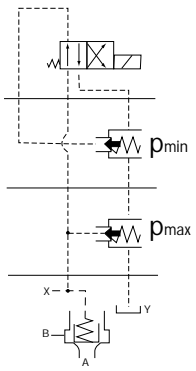
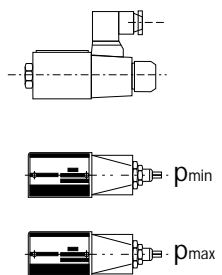
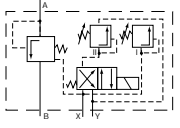
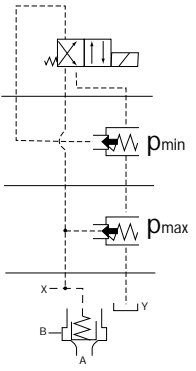
Pressure relief valve with solenoid pressure selection

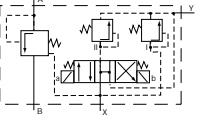
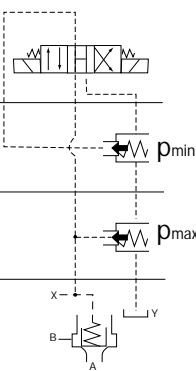
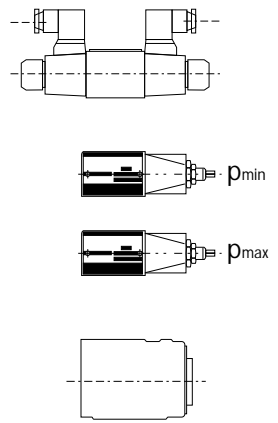
<p>14</p> 	<p>Solenoid controlled low pressure / high pressure</p>		<p>I</p> 
<p>16</p> 	<p>Solenoid controlled high pressure / low pressure</p>		<p>II</p> 
<p>18</p> 	<p>Solenoid controlled normally vented 2 pressure solenoid a: p_{min} solenoid b: p_{max}</p>		

Dimensions

Inches (millimeters)

Port configura-

**ISO 6264 - CETOP
RP 69 H, Form P**

NG 10

Symb. **06**

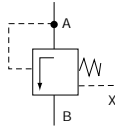

33

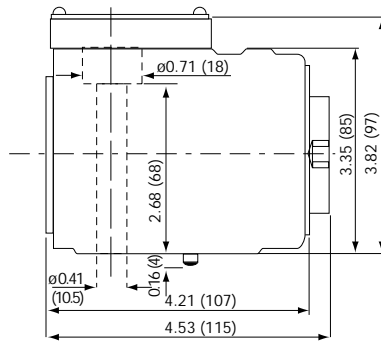
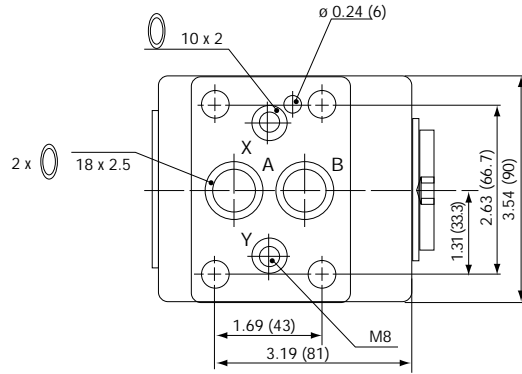
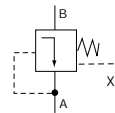

NG 25

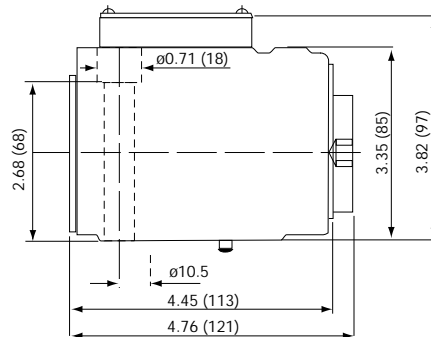
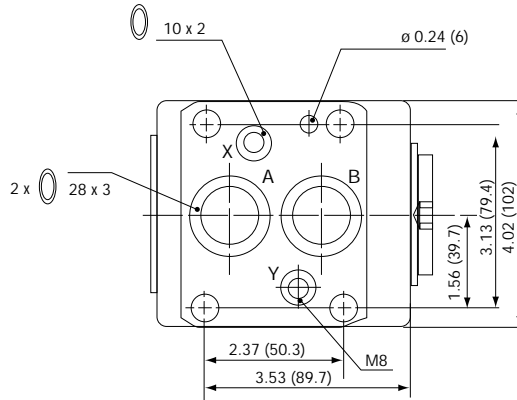

Dimensions

Inches (millimeters)

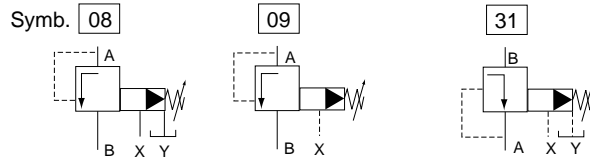

Port configura-

**ISO 6264 - CETOP
RP 69 H, Form P**

NG 10

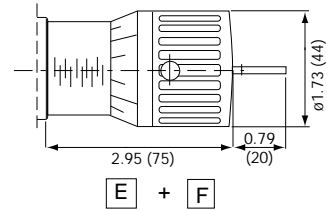
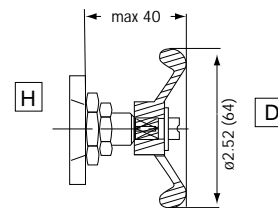
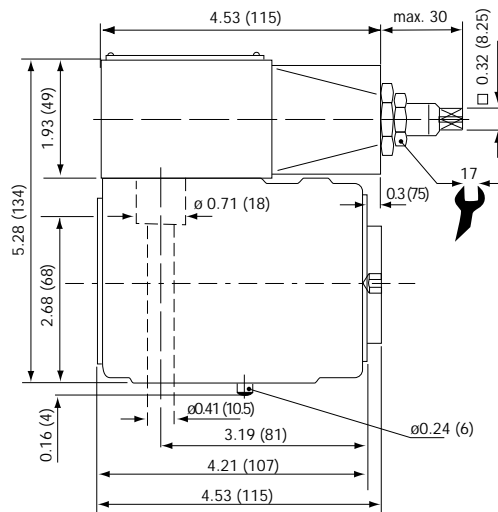

NG 25

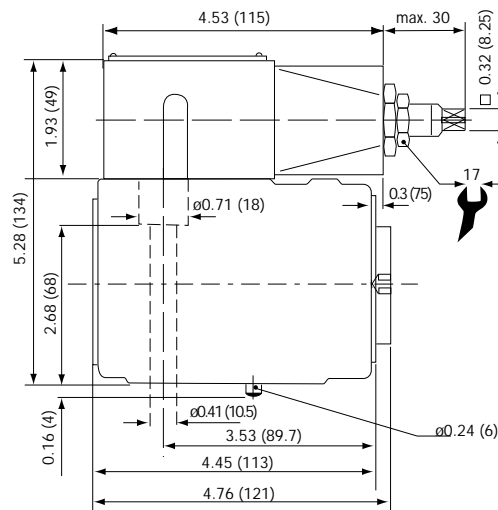

Dimensions

Inches (millimeters)

Port configura-

**ISO 6264 - CETOP
RP 69 H, Form P**

NG 10

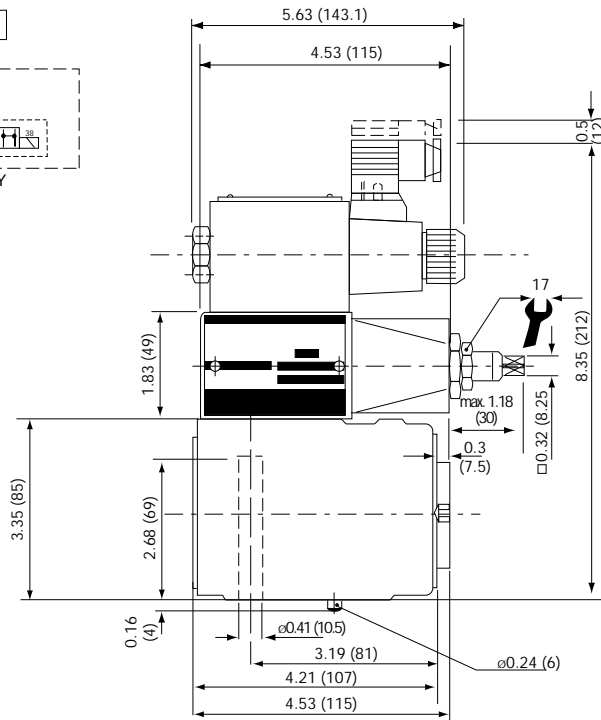
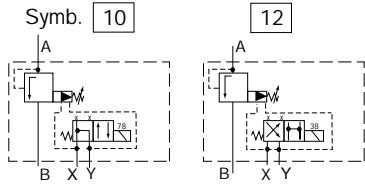

NG 25

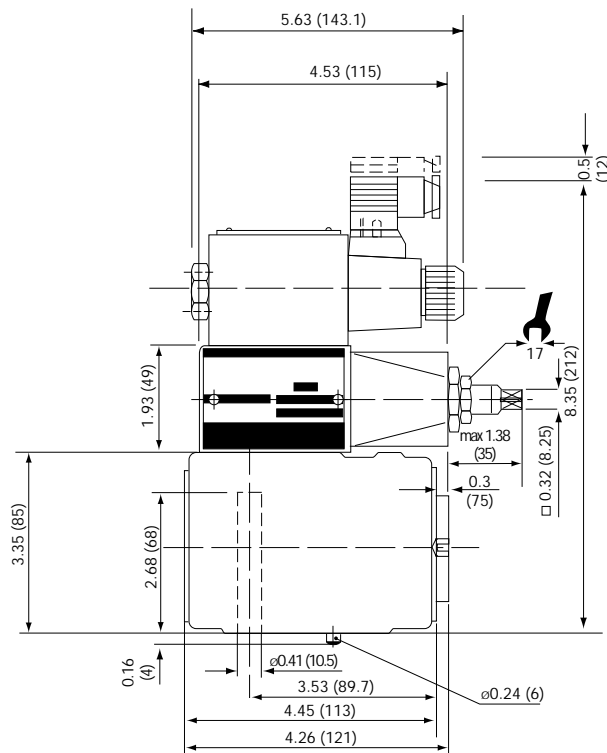

H

Dimensions

Port configura-

ISO 6264 - CETOP
RP 69 H, Form P

Inches (millimeters)

Symb.

14

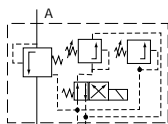

16

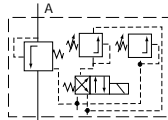

18

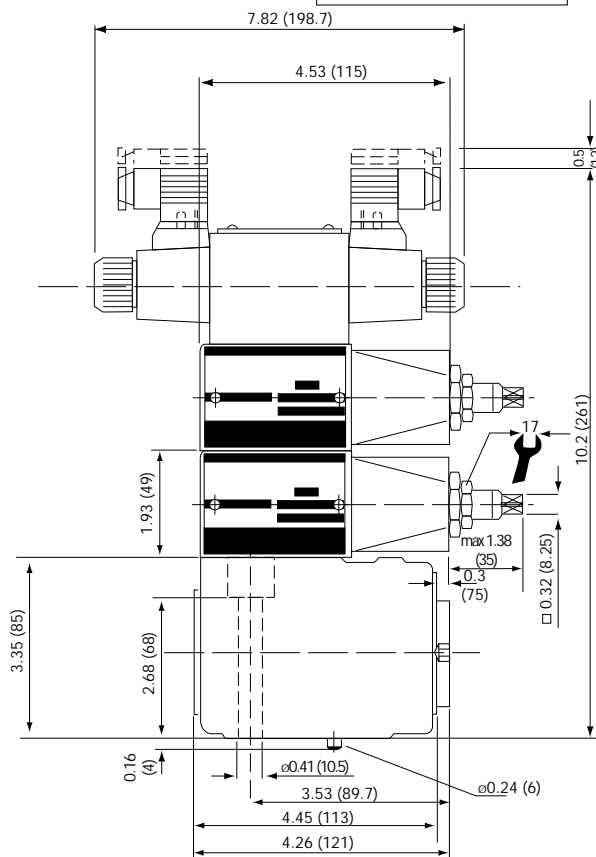
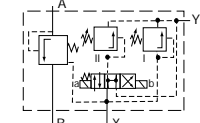

NG 10

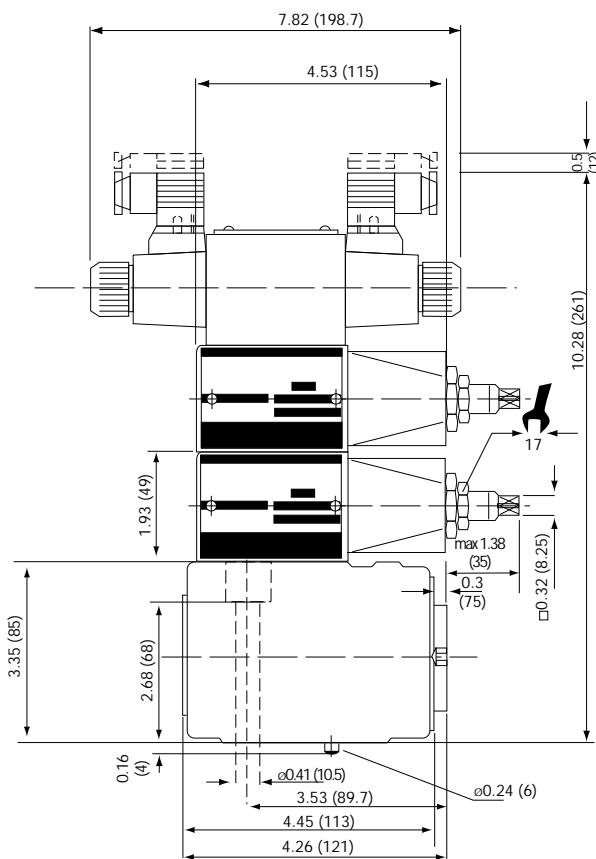

NG 25

Dimensions

Inches (millimeters)

Port configura- Type R
 (Consult factory for availability)

Symb. 06

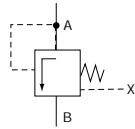

09

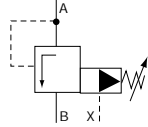

11

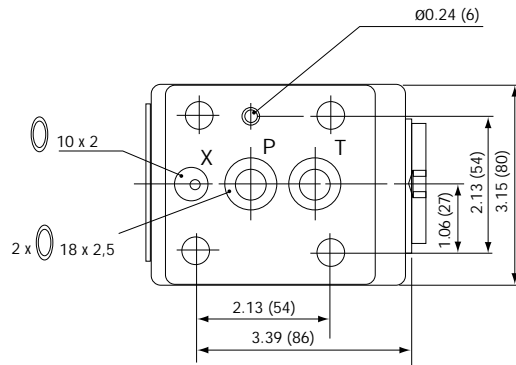
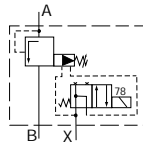

NG 10

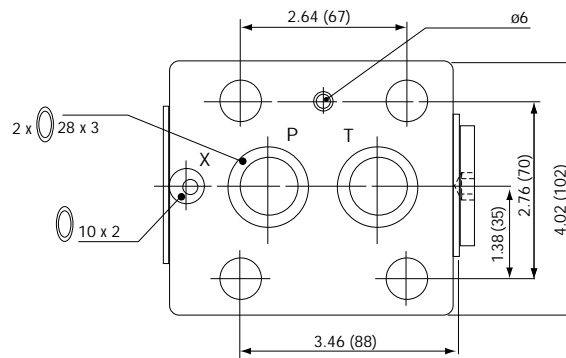
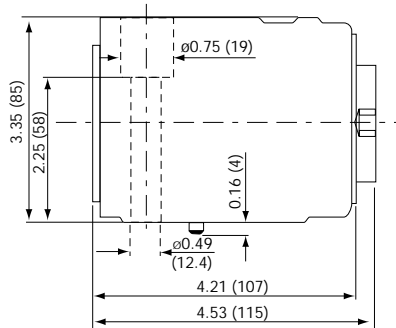

NG 25

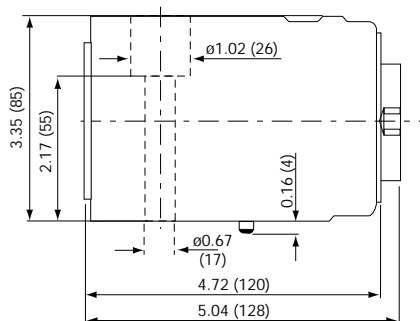

Relief valves

- Pilot valves for NG 10 – NG 25

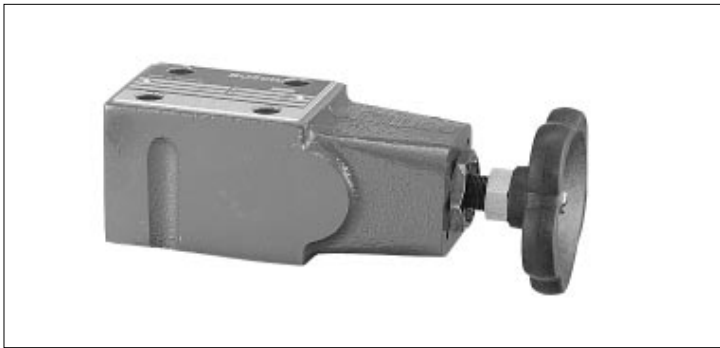

Application of pilot valves

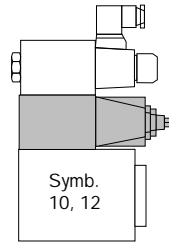
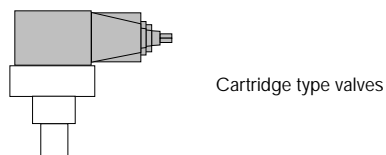
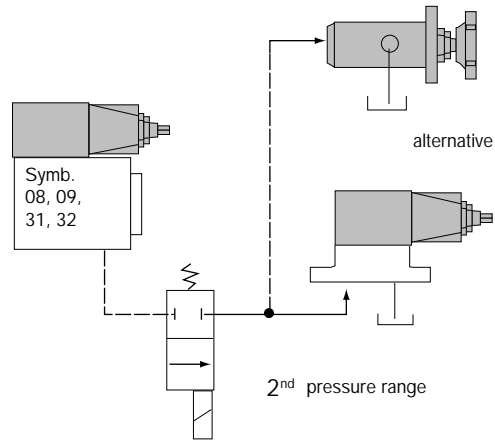
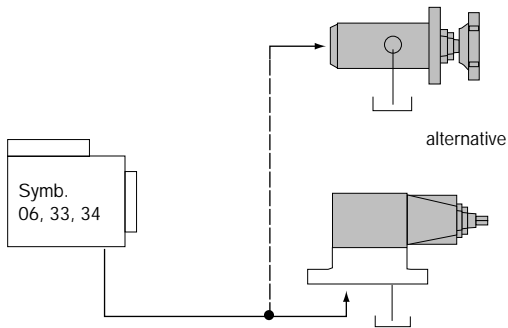
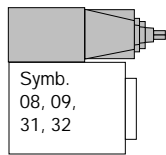

Electric venting

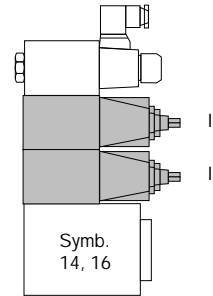

2 Pressure stages

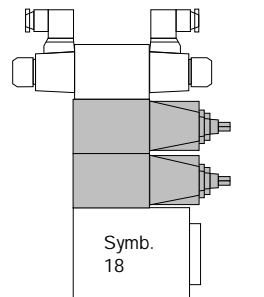

Venting and
2 pressure stages