

传感器技术

Sensor technology

▶ 该培训系统由基础组件，扩展组件和内容丰富的用于工业传感器技术培训的软件组成。它将最新的高科技工业元件与现代化的培训有机地结合起来。

特别是超声波测量装置与导向装置的组合，代表着长度测量技术的最新发展动态。装备的 Ultra 3.0 分析程序可以使系统进行更广范围的测量。该装置功能全，从材料识别和开关频率测量，一直到距离测量均可供您选择。

▶▶ The training programme comprises standard equipment, extension package, and a comprehensive teachware programme for training and further education in industrial sensor technology. This unique concept combines the latest hightech industrial components with the advantages of modern training.

In particular, the ultrasound gauge in combination with a guide unit reflects state-of-the-art length measurement technology. Equipped with the Ultra 3.0 analysis programme, the system can be used to conduct extensive tests. This equipment offers a wide spectrum of features rang-

ing from material recognition and switch frequency measurements to distance measurements.

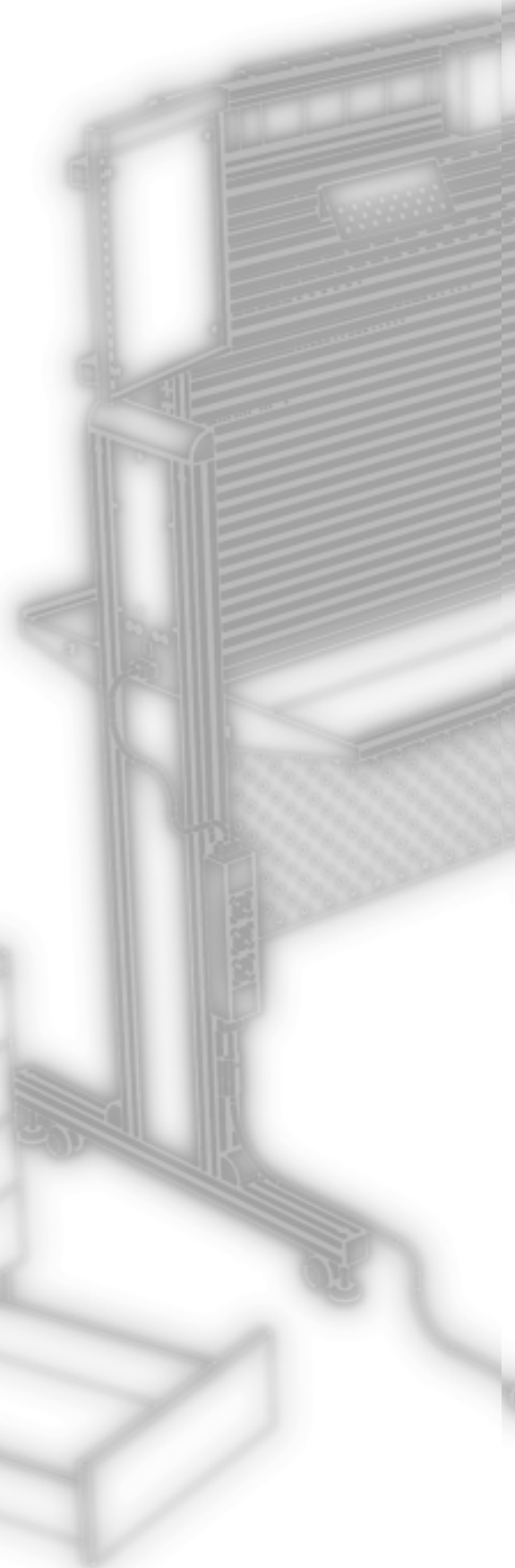



成套组件
Kits

4-2 — 4-6

元件
Components

4-2 — 4-16

培训软件
Teachware

4-17

成套组件

Kits



4-3

1 827 003 575*

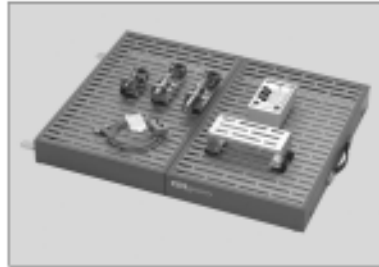

4-3

1 827 003 576*

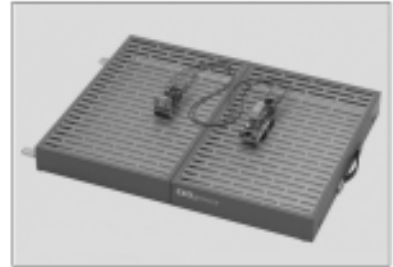

4-4

1 827 003 631*

槽板式培训箱

Grooved plate case



1 827 003 658

4-12



4-5

1 827 003 632*



4-5

1 827 003 673*



4-4

1 827 003 525



4-6

1 827 003 524

▶ 图示中的槽板式培训箱需单独订货。

▶▶ The pictured grooved plate case is not a part of the delivery

▶ S_n = 检测范围

▶▶ S_n = Measured switching distance/dedection range

成套组件

Kits

传感器技术的基本组件

Standard kit

数量	零件号	描述
9 x	1 827 003 215	5-11
10 x	1 827 003 216	5-11
9 x	1 827 003 217	4-15
1 x	1 827 003 640	4-8
1 x	1 827 003 641	4-8
1 x	1 827 003 642	4-8
1 x	1 827 003 655	4-10
1 x	1 827 003 587	5-7
1 x	1 827 003 645	4-9
1 x	1 827 003 647	4-9
1 x	1 827 003 648	4-9
1 x	1 827 003 649	4-9
1 x	1 827 003 654	4-10
1 x	1 827 003 656	4-10
1 x	1 827 003 657	4-10

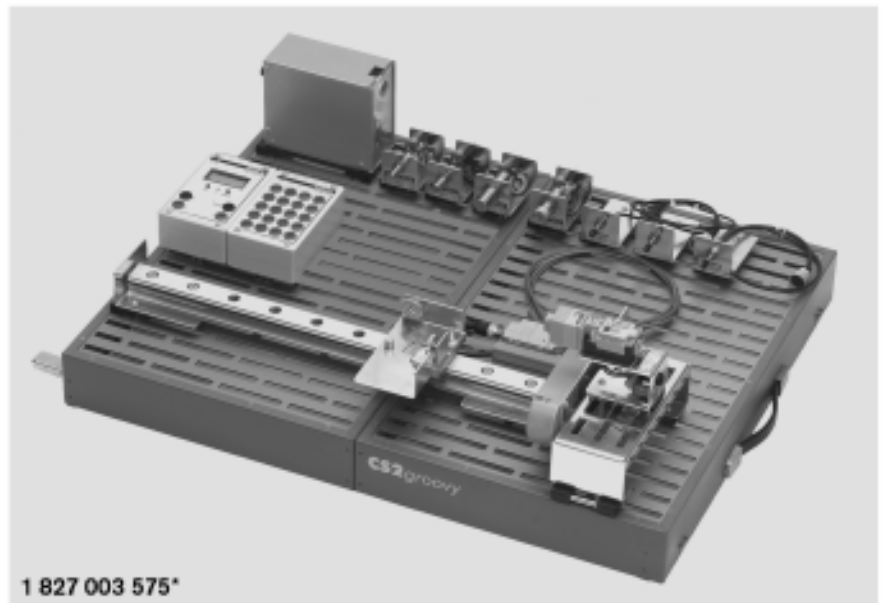

传感器技术的扩展组件

Extension kit

数量	零件号	描述
1 x	1 827 003 640	4-8
1 x	1 827 003 635	4-11
1 x	1 827 003 669	4-11
1 x	1 827 003 637	4-11
1 x	1 827 003 638	4-11

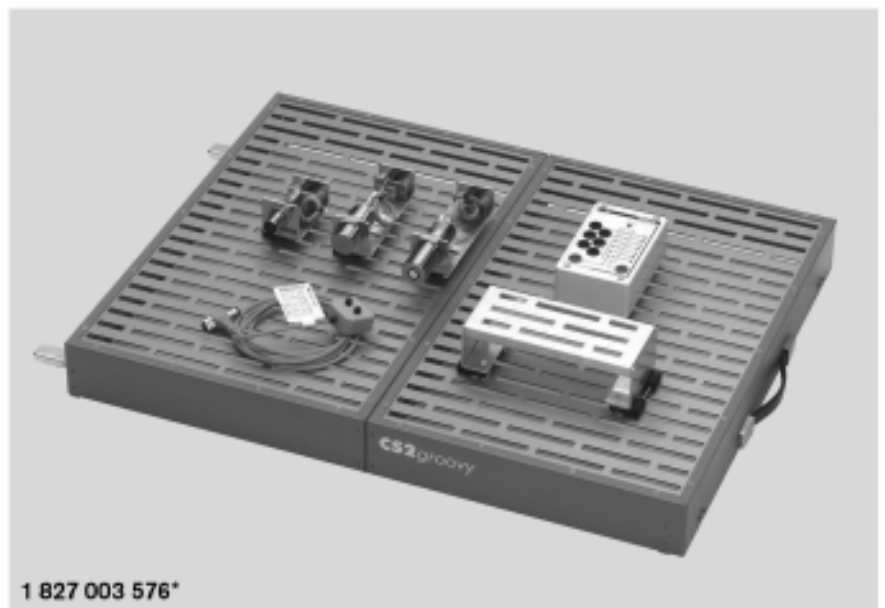

成套组件

Kits

补充组件 Namur

Namur supplement kit

		
1 x	1 827 003 660	4-12
1 x	1 827 003 667	4-12

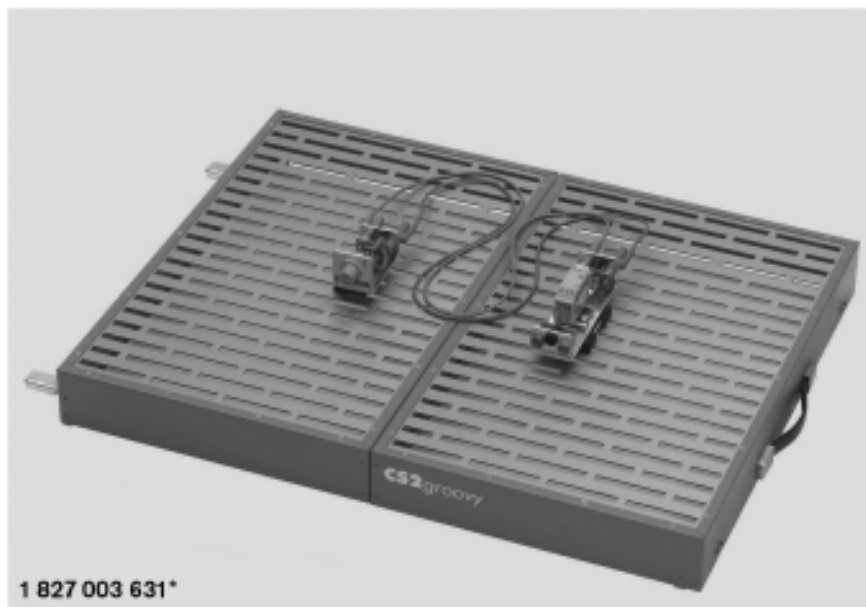

自动化技术补充组件

Automation technology

		
1 x	1 827 003 663	4-15
1 x	1 827 003 664	4-16
1 x	1 827 003 661	4-16
1 x	1 827 003 662	4-16
1 x	1 827 003 679	4-16



成套组件

Kits

AS-I 接口技术培训箱

AS-Interface training case

1 x	1 827 003 672	4-13
2 x	1 827 003 071	4-12
1 x	1 827 003 644	4-14
2 x	1 827 003 532	4-14
1 x	1 827 003 066	4-13
2 x	1 827 003 523	4-8
2 x	1 827 003 217	4-15
1 x	1 827 003 068	4-13
1 x	1 827 003 069	4-13
2 x	1 827 003 070	4-14

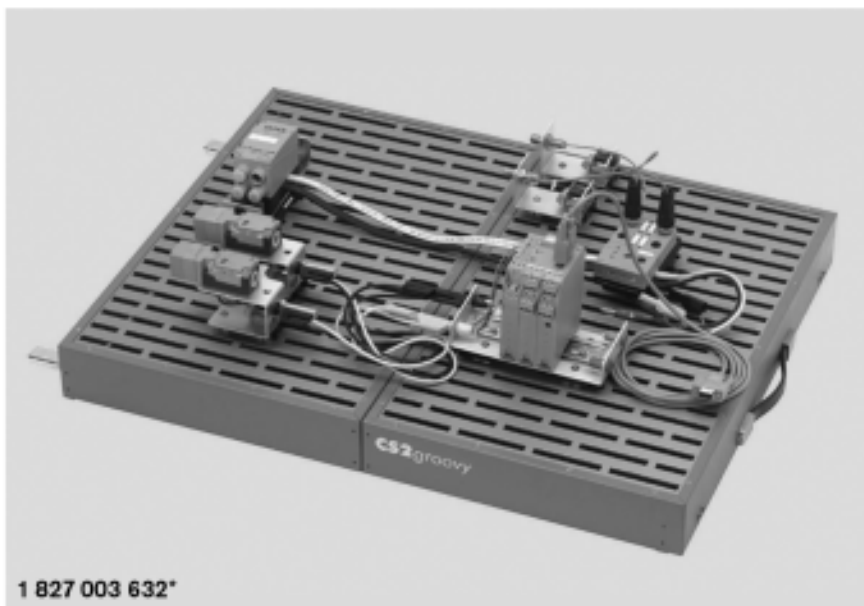

可选项

Opzione

1 x	1 827 003 658	4-12
-----	---------------	------

AS-I/Profibus DP 技术培训箱

AS-Interface training case /
Profibus DP

1 x	1 827 003 674	4-15
1 x	1 827 003 675	4-15
2 x	1 827 003 071	4-12
1 x	1 827 003 644	4-14
2 x	1 827 003 532	4-14
1 x	1 827 003 066	4-13
2 x	1 827 003 523	4-8
2 x	1 827 003 217	4-15
1 x	1 827 003 068	4-13
1 x	1 827 003 069	4-13
2 x	1 827 003 070	4-14

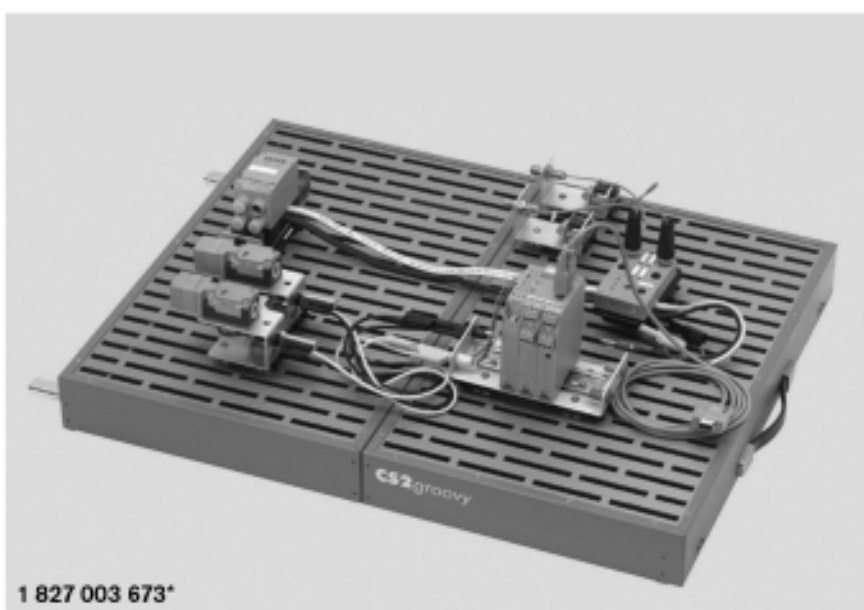

成套组件

Kits

材料样品箱

Material sample case



1 827 003 524

元件

Components



4-8 1 827 003 640



4-8 1 827 003 641



4-8 1 827 003 642



4-8 1 827 003 523



4-9 1 827 003 645



4-9 1 827 003 647



4-9 1 827 003 648



4-9 1 827 003 649



4-10 1 827 003 654



4-10 1 827 003 656



4-10 1 827 003 657

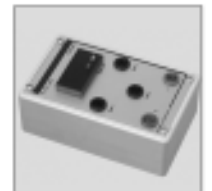

4-10 1 827 003 655



4-11 1 827 003 635



4-11 1 827 003 637



4-11 1 827 003 658



4-11 1 827 003 669



4-12 1 827 003 660



4-12 1 827 003 667



4-12 1 827 003 650



4-12 1 827 003 071



4-13 1 827 003 672



4-13 1 827 003 066



4-13 1 827 003 068



4-13 1 827 003 069



4-14 1 827 003 644



4-14 1 827 003 532



4-14 1 827 003 552



4-14 1 827 003 070



4-15 1 827 003 674



4-15 1 827 003 675



4-15 1 827 003 217



4-15 1 827 003 663



4-16 1 827 003 664



4-16 1 827 003 661



4-16 1 827 003 662



4-16 1 827 003 679

元件

Components

▶ 传感器安装架

▶▶ Height compensation for
snap-in sensors



1 827 003 640

▶ 导向机构, 450 mm 长, 带超声波 装置 + Ultra 3.0 软件

▶▶ 450 mm guide unit with
ultrasound gauge + Ultra 3.0
software

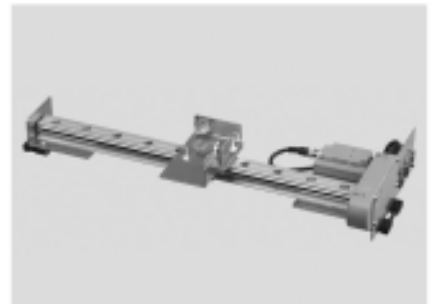

1 827 003 641

▶ 带调节器的电机单元

▶▶ Motor unit with regulator



1 827 003 642

▶ 测量导线, 500 mm 长, 黄色

▶▶ Measuring cable 500 mm, yellow



1 827 003 523

元件

Components

▶ 电感式传感器, $s_n = 8 \text{ mm}$ 

4-2

▶▶ Inductive sensor $s_n = 8 \text{ mm}$ 

4-2

▶ 电感式传感器, $s_n = 2 \text{ mm}$ 

4-2

▶▶ Inductive sensor $s_n = 2 \text{ mm}$ 

4-2

▶ 电容式传感器, $s_n = 8 \text{ mm}$ 

4-2

▶▶ Capacitive sensor $s_n = 8 \text{ mm}$ 

4-2

▶ 磁性传感器, $s_n = 60 \text{ mm}$ 

4-2

▶▶ Magnetic field sensor $s_n = 60 \text{ mm}$  4-2

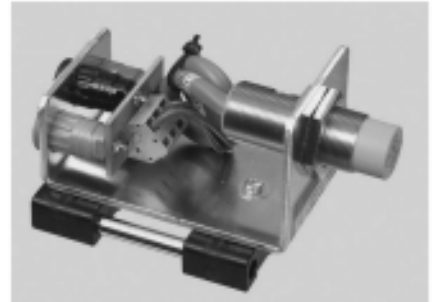

1 827 003 645

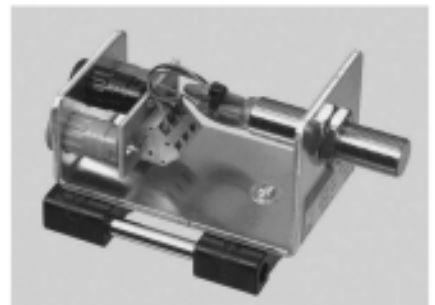

1 827 003 647

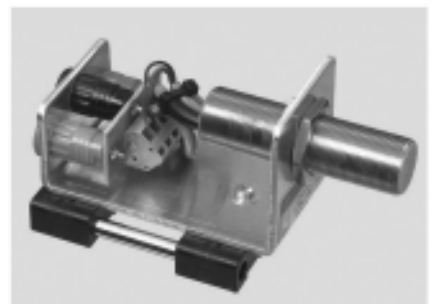

1 827 003 648



1 827 003 649

元件

Components

▶ 反射式光电传感器, $s_n = 200$ mm

▣ 4-2

▶▶ Reflection light scanner $s_n = 200$

mm ▣ 4-2

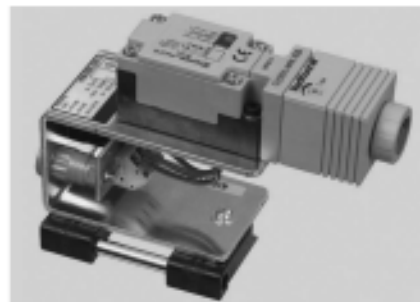

1 827 003 654

▶ 直接反射型光纤

▶▶ Key-operated optical waveguide



1 827 003 656

▶ 对射型光纤

▶▶ Single-mode optical waveguide



1 827 003 657

▶ TSI 频率计数器

▶▶ TSI frequency counter element

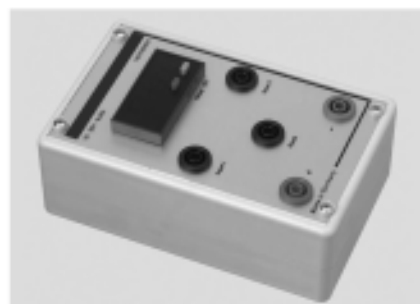

1 827 003 655

元件

Components

▶ 电感式模拟量传感器，测量范围
3-8 mm

▶▶ Inductive analogue transducer
3-8 mm measuring range



1 827 003 635

▶ 超声波传感器， $s_n = 60-300$ mm
4-2

▶▶ Ultrasound sensor $s_n = 60-300$
mm 4-2



1 827 003 637

▶ 反射式光栅， $s_n = 3000$ mm
4-2

▶▶ Reflection light barrier $s_n = 3000$
mm 4-2



1 827 003 638

▶ 数字式材料识别器

▶▶ Analysis unit for digital material
differentiation



1 827 003 669

元件

Components

▶ 防暴型电感式传感器，DIN EN 60947-5-6

▶▶ Ex-protected inductive sensor
DIN EN 60947-5-6

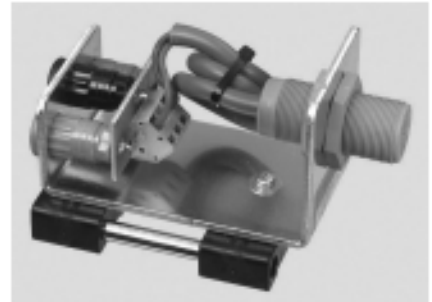

1 827 003 660

▶ 传感器输出转换器，带导线折断监控

▶▶ Sensor output transformer with
line break monitoring

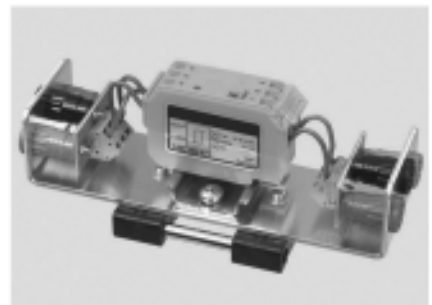

1 827 003 667

▶ BUS 监控器

▶▶ BUS monitor

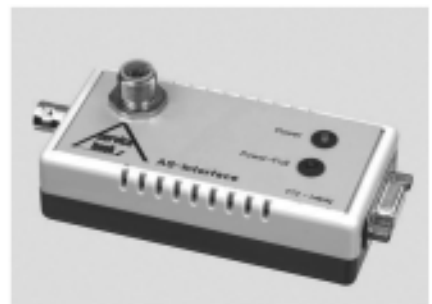

1 827 003 658

▶ AS-I 传感器

▶▶ AS-Interface sensors

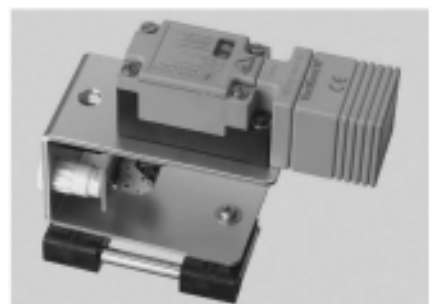

1 827 003 071

元件

Components

▶ AS-I 控制器，带 RS232 接口

▶▶ AS-Interface control master with RS232 Interface



1 827 003 672

▶ 电源（代替 AS-I 电源）

▶▶ Power extender (replaces the AS-Interface power supply unit)



1 827 003 066

▶ AS-I 扁形电缆，黄色

▶▶ AS-Interface cable, flat, yellow



1 827 003 068

▶ AS-I 扁形电缆，黑色

▶▶ AS-Interface cable, flat, black



1 827 003 069

元件

Components

▶ 两个 I/O 模块，用于连接两个非 AS-I 协调传感器 (I) 和执行元件 (O)

▶▶ 2 I/O modules for connecting two non-AS-Interface-compatible sensors (I) and actuators (O)



1 827 003 644

▶ 电感式双导线传感器

▶▶ Inductive two-wire sensor



1 827 003 532

▶ 空的组件箱

▶▶ Empty case for kits



1 827 003 552

▶ 用于连接传感器 / 执行元件到两个 I/O 模块上的插头

▶▶ Plug for connecting sensors / actuators to the 2 I/O module



1 827 003 070

元件

Components

▶ AS-I 控制器, 带 Profibus DP

▶▶ AS-Interface control master with Profibus DP Interface Control master de la Interface AS



1 827 003 674

▶ Profibus 模拟器

▶▶ Profibus Simulator

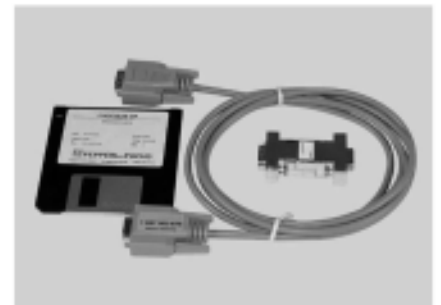

1 827 003 675

▶ 测量导线, 500 mm 长, 黑色

▶▶ Measuring cable 500 mm, black



1 827 003 217

▶ 步进电机, 带轴驱动装置

▶▶ Step motor with spindle drive

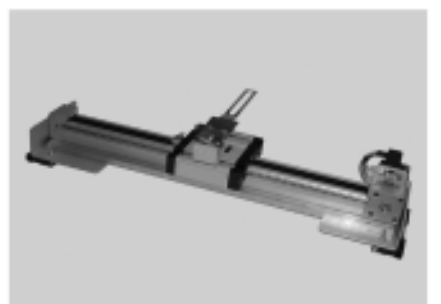

1 827 003 663

元件

Components

▶ 步进电机电子控制器

▶▶ Control electronics for step motor



1 827 003 664

▶ 带固定板的直接反射型光纤

▶▶ Key-operated optical waveguide with retaining plate



1 827 003 661

▶ 带扫描矩阵的条

▶▶ Strip with scanning matrix

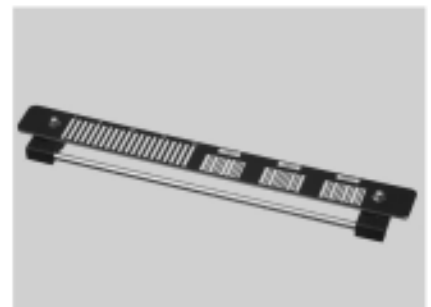

1 827 003 662

▶ 组件箱子(空的), 用于自动化技术组件

▶▶ Empty case for automation kit



1 827 003 679

光盘

▶ 所有的传感器培训教程均有德文和英文两种版本

内容:

理论手册, 练习题集, 答案和实验结果评定, 数据表, PLC 实验练习和Ultra 3.0分析程序

光盘

▶ 所有的传感器培训教程膜片均有德文和英文两种版本

内容:

传感器技术基础, 电感式传感器, 电容式传感器, 磁性传感器, 超声波传感器, 光电传感器

▶ 更多的信息

▶▶ Further informations

CD-ROM "SETgraphics"

▶▶ with all Training Packages Sensoric in German and English

Contents:

Manual for theory, set of exercises, solutions, data sheets, PLC Experiments and Ultra 3.0 analysis programme



R 961 000 795

CD-ROM "SETgraphics"

▶▶ with all Training Packages Sensoric in German and English

Contents:

SENSORIC transparencies, Basics; SENSORIC transparencies, Inductive sensors; SENSORIC transparencies, Capacitive sensors; SENSORIC transparencies, Magnetic sensors; SENSORIC transparencies, Ultrasonic sensors; SENSORIC transparencies, Optical sensors



R 961 000 796

