

Rexroth IndraMotion for Packaging

Flexible, open and intelligent



Rexroth IndraMotion for Packaging – the intelligent industry solution from the Automation House

IndraMotion for Packaging is a well-engineered industry solution from Rexroth's Automation House family of products. This modular package includes all of the elements you need to successfully deploy your automation designs. The broad portfolio of perfectly matched controllers, HMI devices and drives makes your automation projects virtually as easy as child's play.

The automation solutions used on today's production systems are becoming increasingly sophisticated. Users need higher productivity, greater flexibility, simpler integration and open designs which facilitate system expansion at a later date, and of course they want all of that at lower cost. It takes a partner with in-depth expertise and knowledge of the industry to provide complete, seamless solutions. Customers expect to get a full range of applications with motion control and PLC functionality, which cover everything from the drives to visualization and the HMI.

To give our customers exactly what they need, we continue to drive the development of our systems which already have an enviable reputation around the world.

The result of this development activity is our innovative Automation House, which is a modular family of products which includes all of the components you need for your flexible, intelligent automation solutions. Our modular kits are complete, scalable and future-proof.

- **IndraDrive and IndraDyn**
the drive system platform
- **IndraControl**
the control and visualization platform
- **IndraMotion**
the system software with integrated motion control
- **IndraLogic**
the standardized PLC platform
- **IndraWorks**
the fully-featured engineering framework for all systems

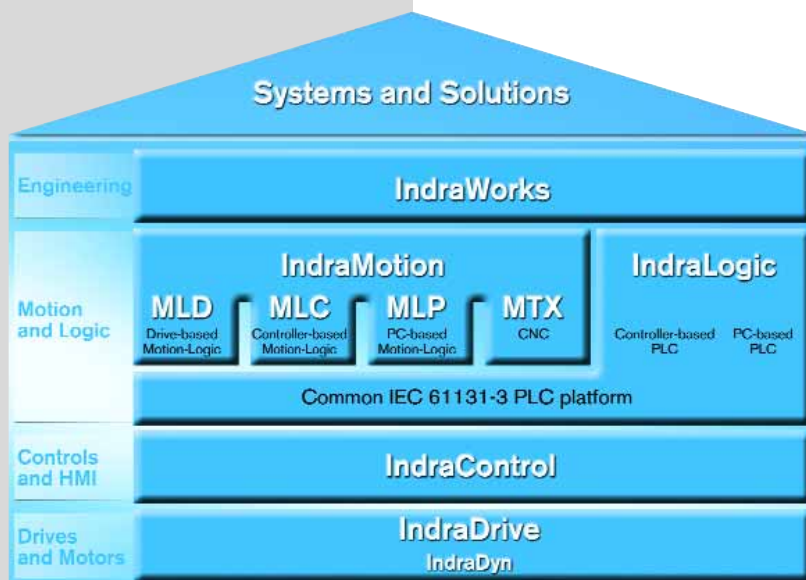

IndraMotion for Packaging is a complete, intelligent solution for the food and packaging industry, and it is based on Rexroth's Automation House. It includes the full range of system components which you need to implement your automation solutions. You get everything from drives and controllers to a powerful engineering framework and a user-friendly HMI.

The market for food and packing machinery is more differentiated and complex than ever, and machine manufacturers are expected to deliver more and more performance and features. IndraMotion for Packaging is the right automation tool for machine manufacturers who are prepared to face up to the challenges. It is the ideal choice for handling solids or liquids in production and for packaging applications in the pharmaceutical and food industries.

IndraMotion for Packaging bundles together Rexroth's extensive experience in providing complete, standardized solutions for all segments of the food and packaging industry:

- food
- beverages
- confectionery
- pharmaceuticals
- cosmetics
- tobacco

These solutions offer a whole range of advantages in any application, from individual machines to entire production lines:

- form and fill systems
- fill and seal machines
- thermoforming, fill and seal systems
- tubular bag machines
- labeling machines
- intelligent sorting machines
- multipacking machines
- cartoners
- pick-and-place robots
- palletizers

**IndraMotion for Packaging –
the open and scalable complete solution**



A competitive advantage for the end user

Global competition presents enormous challenges to manufacturers who produce food, tobacco, beverages, cosmetics or pharmaceuticals. The list of challenges includes low prices, top quality and high flexibility. Producers try to juggle all of these demands by increasing productivity and driving costs down.

The motto is: zero rejects, minimal idle time and fast cycle times throughout the entire process from production right through to final packaging.

IndraMotion for Packaging will help you meet these challenges.

We know, because our systems show what they can do every day in thousands of machines and systems around the world.

Increase your productivity:

- electronic cams
- high-precision drive synchronization solutions
- preventive diagnostics and maintenance
- safety on board to minimize idle time

Get added flexibility:

- faster changeover using electronic synchronization
- standardized communications interfaces
- open programming standards (IEC 61131-3, PLCopen, OMAC)
- Rexroth's cross-technology drive & control expertise

Drive down cost:

- scalable motion control solutions
- process-specific function libraries and technology functions
- fully-featured systems software boosts engineering efficiency
- safety on board reduces component and certification costs

Expect the best response when you need a service call:

- modular system design facilitates simple device swap
- plug-and-play reduces device swap time
- direct access to system using remote diagnostics
- holistic service expertise including 3rd party equipment

Alpenhain Anheuser-Busch Apetito Arla Foods Avon
 B. Braun Barilla Basic American Foods Bauer
 Bausch & Lomb Bayer Bayernland Beiersdorf Best Foods
 Bob Evans Farms Brach's Confections Cadbury Schweppes
 Campbell Soup Campina Chanel Charms Chocolat Frey
 Coca-Cola ConAgra Corwood Labs Danone Dean Foods
 Dial Dixie Dr. Oetker Dr. Pepper Edelweiss Ehrmann
 Ely Lilly Estée Lauder Ferrero Fresenius General Mills
 Gilde Brauerei Griesson - de Beukelaer Häagen-Dazs
 Hartmann Heinz Henkel Henkell & Söhnlein Hershey
 Hochland Hormel ITW Chem Design Johnson & Johnson
 Karwendel Kellogg's Kimberly-Clark Kraft Foods Kroger
 L'Oréal Lilly Mars Master Foods Mc Cain Mc Cormick & Co.
 McKee Foods Mead Johnson Meggle Merck
 Milch-Union Hoheifel Müller-Milch Nabisco Nestlé Pepsi
 Pfizer Philadelphia Chewing Gum Procter & Gamble
 Purina Mills Ralston Foods Revlon Roche Sara Lee Corp.
 Schering-Plough Schick Wilkinson Sword Schreiber Foods
 Schwartauer Werke Schwarz Pharma Scott Seagrams
 Solo Cup Sonoco Storck Straatman Sweetheart
 Tootsie Roll Tropicana Tyson Foods Unilever
 Van Law Food Products Vichy Weyerhaeuser Zott

Flexible automation solutions on standardized platforms

Today, open system architecture is the key to future-proofing your product automation solutions and protecting your investment. These systems offer standardized communications interfaces, open programming standards and modular design. Standardized interfaces enhance device technology and communication and simplify engineering to give you the flexibility you need when you develop your machine and controller configurations.

IndraMotion for Packaging makes uncompromising use of recognized worldwide standards and unlock the door to complete, open system solutions which are based on standardized hardware and software platforms. Drive, controller and PC-based motion logic control solutions give customers the business and engineering performance which they expect from best-in-class architecture.

IndraMotion for Packaging is ideal both as a stand-alone system or a multi-control solution in “total line automation” applications. The open, scalable system solution delivers all of the benefits of standardization and modular design on production systems, starting with the production process and continuing all the way through to the primary, secondary and final packaging stages.

The standardized user interface complies with all current PLC standards



Open communications based on support for all worldwide industry standards



Future-proof basic software for operating systems, middleware and applications



System architecture designed for the long term and simple integration of new technologies



Scalable hardware architecture

IndraMotion MLD
economic solutions
for simple applications

IndraMotion MLC
standard mid-range
to high end solution

IndraMotion MLP
highly-integrated
mid-range solution

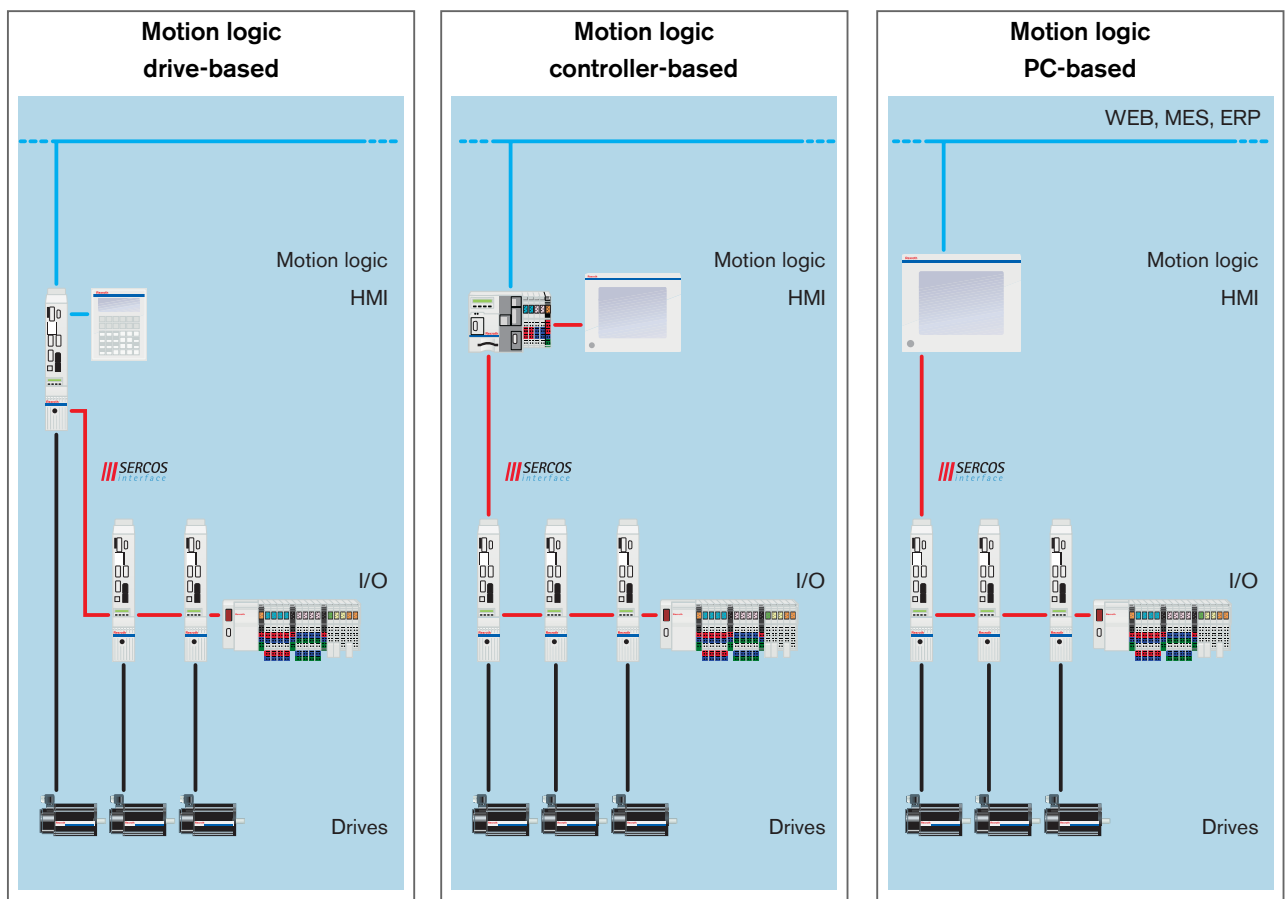

Complete automation system for drive-based, controller-based and PC-based applications

Open communications standards and standardized IEC 61131-3 compliant PLC platform

Controllers, drives, I/O and safety devices link into to the end-to-end SERCOS III system bus

Standardized IndraWorks engineering tool for motion, logic, HMI and drives

Industry-specific function libraries and technology functions

Standardized system software

Rexroth's IndraMotion for Packaging solution consolidates years of automation know-how in a standardized hardware and software platform. The solution is built around the convergence of highly advanced motion control and standardized PLC technology to create complete, integrated solutions. All versions of IndraMotion for Packaging use the same embedded PLC programming and runtime system kernel.

In order to facilitate integration of your state-of-the-art mechatronic solutions, IndraMotion for Packaging offers function libraries and technologies which complement the basic motion logic functionality.

- function libraries containing basic IEC and PLCopen function modules
- technology functions offering process-specific functions for print mark control, tension control, temperature control and much more.
- user libraries containing function modules which integrate customer-specific engineering know-how

The result

A user program which was created using any combination of existing and new function libraries and technology functions.

The advantages

Efficient machine programming reduces cost and saves time. Your programs are more clearly structured, and this added transparency facilitates re-use.

Standardized software architecture with no hardware dependencies

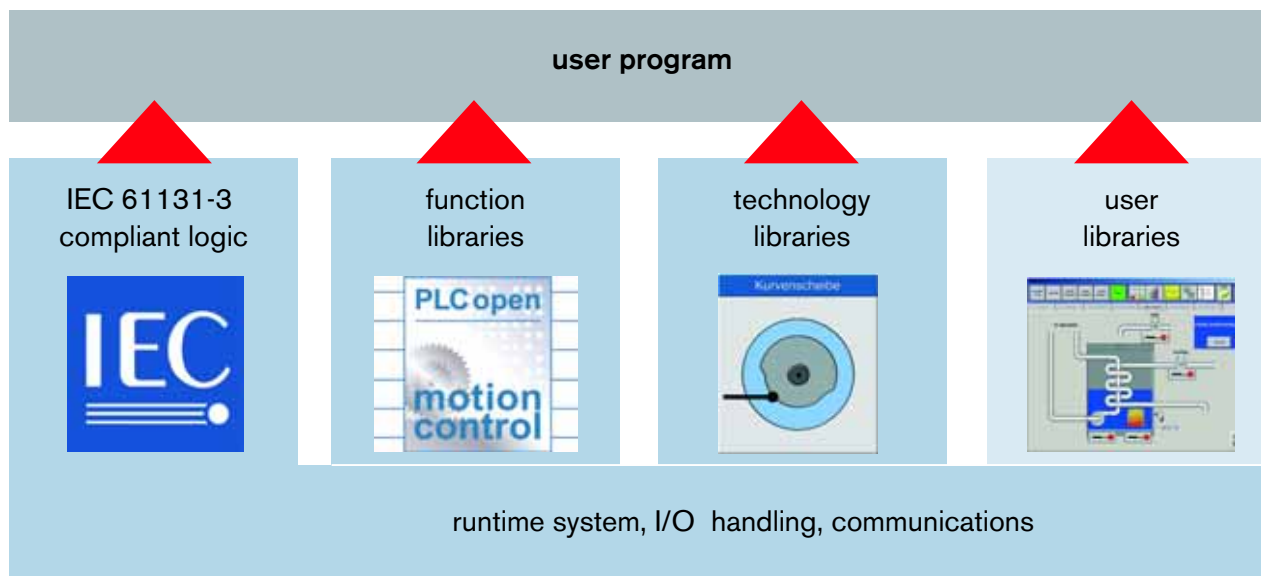

Standardized engineering environment with integrated technology functions

Our ready-to-use function libraries and pre-defined technology functions give you the tools which make it very easy for you to develop large, sophisticated applications. You then use the IndraWorks engineering framework to add these functions to your applications program and speed up configuration and parameterization of the entire system

The advantages

- quick reaction to market and customer requirements
- Ready-to-use function libraries and pre-defined technology functions help you implement complex processes
- efficient modifications for new machine and system designs
- simplified deployment of modular machine control designs

The portfolio

- print mark control
- handling
- crank kinematics
- controller-based and drive-based electronic cam
- cam group
- no gap - no seal
- no product - no bag
- measuring wheel
- touch probe function
- on-the-fly machining
- PID controller
- preventive diagnostics
- cross cutter
- register control
- sag control
- smart belt infeed
- temperature control
- adjusting
- winder
- tension control

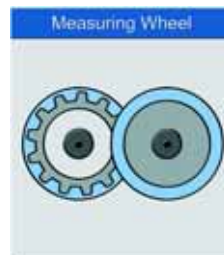
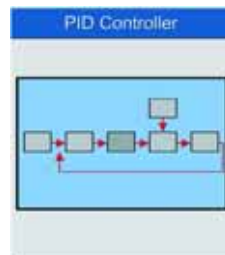
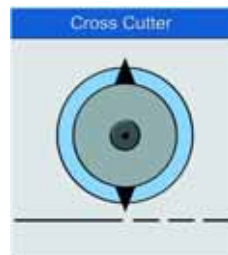
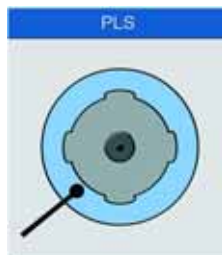

Turnkey technology functions for any process

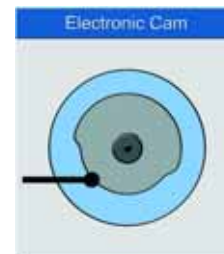
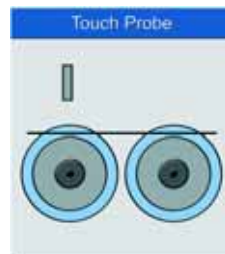
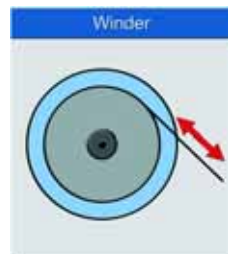
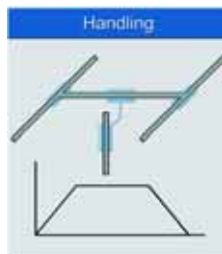

Streamlined engineering helps reduce time to market

Rexroth IndraWorks gives you all of the engineering tools you need in a single engineering environment, and you can use it for all of our automation systems. The fully-featured framework guides you through every step of the planning and programming process right through to visualization and diagnostics.

The big picture

IndraWorks provides an easy way of grouping your controllers and HMI devices. It does not matter whether you are working on a distributed system with controller on a network or a complex machine with centralized control and distributed HMI units. When you have a complex set of interfaces, IndraWorks makes sure that you always have the big picture.

Distributed Engineering

To get through the startup phase quicker, IndraWorks allows a number of engineers to work in parallel on various subsystems in an automation project.

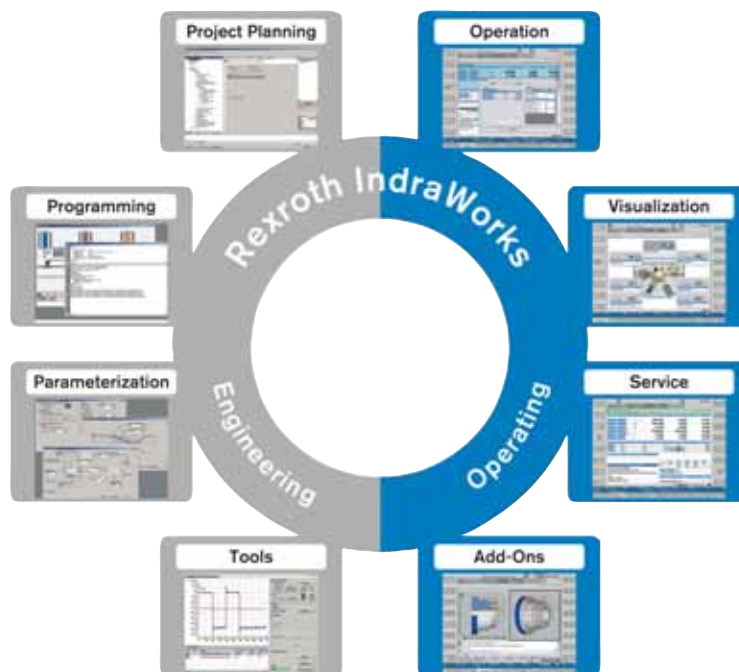

With Rexroth IndraWorks, you use a single software package for all of your engineering work on any industry application.

Customized configuration

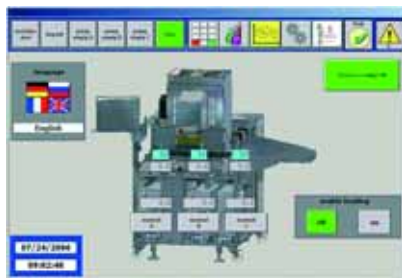

System diagrams, maintenance notes, online documentation and electronic handbooks can easily be added to the standard user interface. ActiveX controls provide an elegant way of adding complex visualization features.

Simple process monitoring

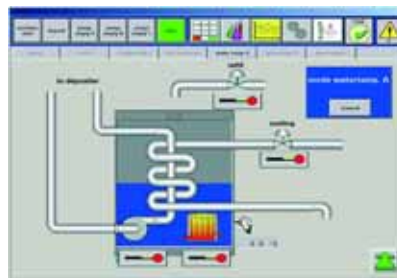

Open communications interfaces facilitate data access right down to the drive parameter level. All of the relevant data reflects the latest process status.

System features

1. Hardware	IndraMotion MLD	IndraMotion MLC	IndraMotion MLP (▼)
1.1 Number of axes	8	32 (64▼)	32
1.2 On-board interfaces			
SERCOS II		●	
SERCOS III	●	○	●
Ethernet (TCP/IP)	●	●	●
PROFIBUS	slave	master/slave	○
inputs/outputs	4 per drive	8/8	
RS232	●	●	
1.3 Function modules			
PROFIBUS master		○	
DeviceNet master		○	
high-speed cam group		○	
cross-communication interface		○	
leading axis transducer		▼	
SERCOS III		○	
1.4 External inputs/outputs			
Inline (IP20)		○	○
Fieldline (IP67)		○	○
SERCOS III	●	▼	▼
1.5 Drives supported			
IndraDrive	●	●	●
IndraDrive Fc (via fieldbus)		●	○
3rd party (via fieldbus)		●	○
1.6 HMI integration			
IndraControl VCP	●	●	
IndraControl VEP	●	●	
IndraControl VSP	●	●	
3rd party (on request)	○	●	
1.7 Pneumatic connection			
DDL	●	○	○
1.8 Remote maintenance			
Ethernet	●	●	●

● Standard

○ Option





▼ In preparation

2. Software	IndraMotion MLD	IndraMotion MLC	IndraMotion MLP (▼)
2.1 Programming			
Project templates	●	●	●
Motion control	●	●	●
Robot control		●	●
2.2 IndraWorks engineering framework			
Project management	●	●	●
System configurator	●	●	●
Library administration	●	●	●
Fieldbus and I/O configurator	●	●	●
Cam editor	●	●	●
IEC 61131-3 compliant programming	●	●	●
Online/offline switching	●	●	●
Startup wizards	●	●	●
Diagnostics and debugging	●	●	●
Firmware administration	●	●	●
2.3 Motion control			
Single axis with moment control	●	●	●
Single axis with speed control	●	●	●
Single axis positioning	●	●	●
ELS with angular synchronization	●	●	●
ELS with speed synchronization	●	●	●
Drive-based cams	4 per drive	4 per drive	4 per drive
Controller-based cams		2 per drive	2 per drive
Segmented cam profile	●	●	●
Virtual master	●	●	●
Real master	●	●	●
2.4 Robot control			
Kinematic transformation		●	●
Maximum number of interpolation axes		6	6
Belt synchronization (belt tracking)		●	●
Linear interpolation		●	●
Circular interpolation		●	●
Point-to-point		●	●
Speed control (path and axes)		●	●
Acceleration control (path and axes)		●	●
Overlooping		●	●
Protection zones		▼	▼
Teach-in function		▼	▼

Total line automation with Rexroth – expertise in every dimension

Whether you are producing or packaging food, beverages, tobacco, pharmaceuticals or cosmetics, the performance capabilities of the automation solution play a major role when you join up the individual machines and process steps to create highly flexible production lines.

IndraMotion for Packaging gives you all of the advantages of a fully modular, open automation solution, starting with the production process and continuing right up to primary, secondary and final packaging. Multi-tasking modes including single-axis positioning, multi-axis synchronization and coordinated path movement provide the ideal basis for machine automation in any application.

	Production
 <p>Food, dry</p>	<p>Baking bread Curing meat</p>
 <p>Food, liquid</p>	<p>Chesse production Butter dispensing</p>
 <p>Beverages</p>	<p>Bottling and capping</p>
 <p>Confectionery</p>	<p>Form and fill Ice cream production</p>
 <p>Pharmaceuticals</p>	<p>Granulate compaction Needle production</p>
 <p>Cosmetics</p>	<p>Lipstick filling Screw feeder</p>
 <p>Tobacco</p>	<p>Cigarette production</p>

Primary packaging

Cutting bread

Intelligent sorting

Piston filling

Multipacking

Tea bag production

Starpping for shipment

Vertical form, fill and seal

Secondary packaging

Labeling

Carton erection

Palettizing

Shrink packaging

Thermoforming, fill and seal

Tube filling

Sausage cutting

Final packaging

Horizontal form, fill and seal

Cartoning

Pick-and-place

Stretch wrapping

Bag packing

Rexroth automation solutions – Milestones in packaging technology

The name Rexroth stands for innovation and future-proof solutions in the world of packaging machine engineering. Our ongoing development activity continues to drive the evolution of packaging machinery:

- Generation II – intelligent servo drives and realtime communications via the SERCOS interface
- Generation III – electronic line shaft and PC-based controller architecture with up to 40 servo axes
- GenNext – Rexroth multi-technology solutions for maximum distributed intelligence

- Generation III**
Machine drive with electronic shaft
- excellent flexibility and automated changeover
 - short lead times and low operating costs
 - drastic reduction in mechanical elements

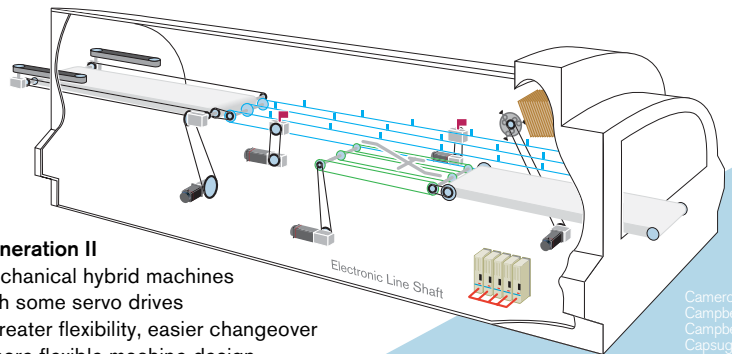

- Generation II**
Mechanical hybrid machines with some servo drives
- greater flexibility, easier changeover
 - more flexible machine design
 - some reduction in mechanical elements

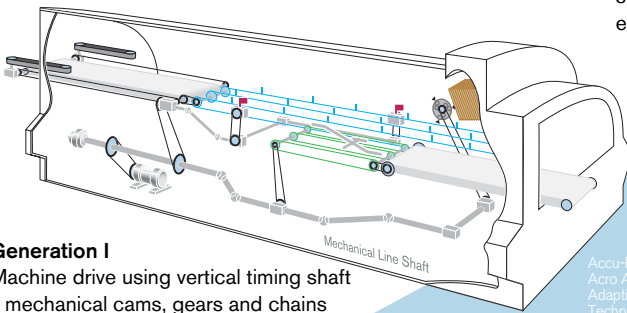

- Generation I**
Machine drive using vertical timing shaft
- mechanical cams, gears and chains
 - inflexible
 - high cost maintenance

A & F GmbH
A. & F. Snc
A.R.C.I.L. SA
Aagard
Aasted

Accu-Pak
Acro Automation
Adaptive Manufacturing Technologies
Adco
Adolf Illig
Advanced Air Products
Advanced Technology
Alcoa
Aldepack
All Fill

Allen Machinery
Allgemeine Behälter
Allisyncro
Alloyd
Allpac
Alvey
Alza
Ameripak
AMF
AMI
Amoco
Ampack-Ammann GmbH & Co. KG
Ampak
Amplas
Anton Egger
Appleton Papers
APV Baker
Armec
Arrowhead Conveyor
Associated Packaging
ATB GmbH
ATIA

Autoprod
Autowrappers
Aylward Industries
B&B Automation
Bafag Bäckereinrichtungen
Banner Packaging
Battenfeld Gloucester
Bay Packaging
Bemis
Benchmark
Benz + Hilgers GmbH
Berning Maschinenfabrik
Big Drum GmbH
Bindler
Blind Maschinenbau GmbH
Blueprint
Blueprint Automation B.V.
Blum
Bodolay
Bosch Packaging
Bradman-Lake
Brenton Engineering
Brown Machine
Buehler AG
Bühler Bindler GmbH
Buhmann Systeme GmbH
Burrows Paper
BWI Fords Holmatic

Cameron & Barkley
Campbell Hardage
Campbell Wrapper
Capsugel
Carle e Montanari S.p.A.
Carlton Bates
Cassady
CATTI 27
Cavanna S.p.A.
CFS Germany GmbH
Chesapeake Packaging
Cloud
CMA
CMD
Columbia
Constar International
Corpak
CP
Cryovac
Cryovac Sealed Air Corp
Culbro
Curwood
Custom Machinery Design
Cyro Industries
Davis Engineering
Delta Automation
Design Services
DILCO Service
Dienst Sondermaschinen
Dimension Industries
Distinctive Engineering
Dividella AG
Dobby

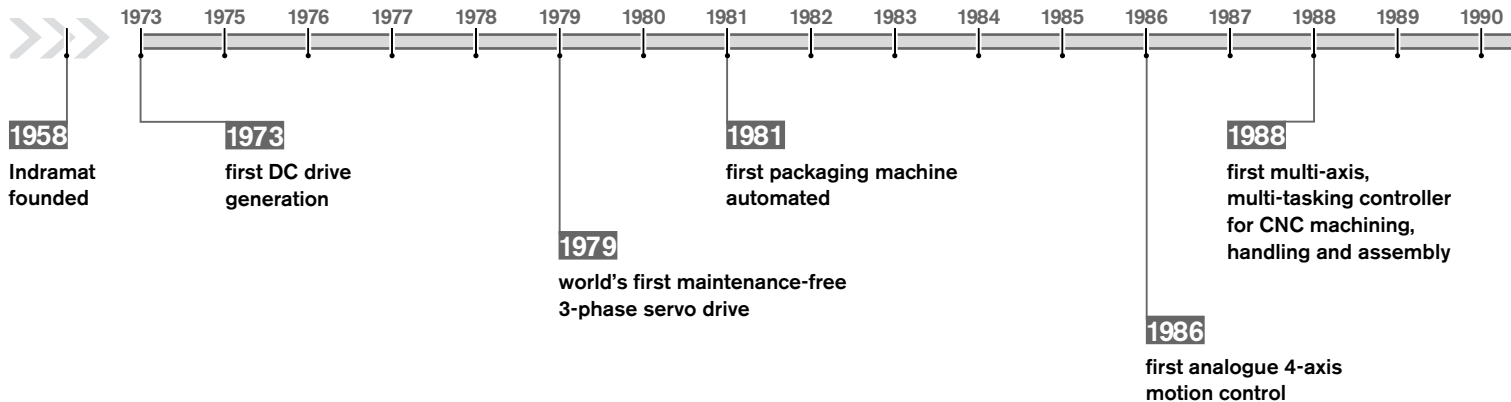

GenNext

Machine automation based on Rexroth multi-technology solutions

- one controller for all drive technologies
- one engineering tool for all Rexroth products
- standardized SERCOS III system bus
- on-board safety technology

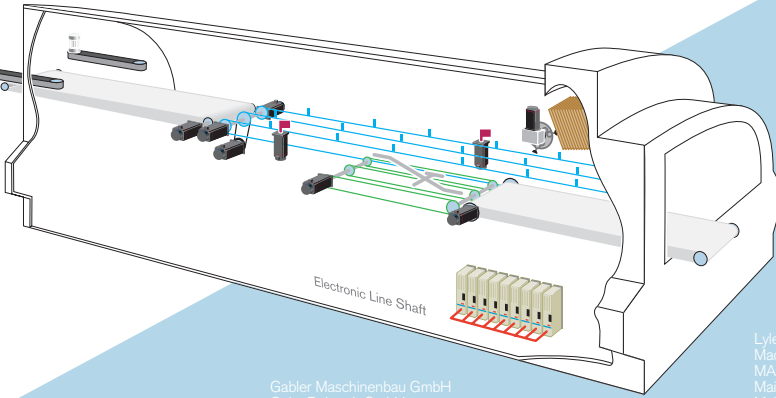
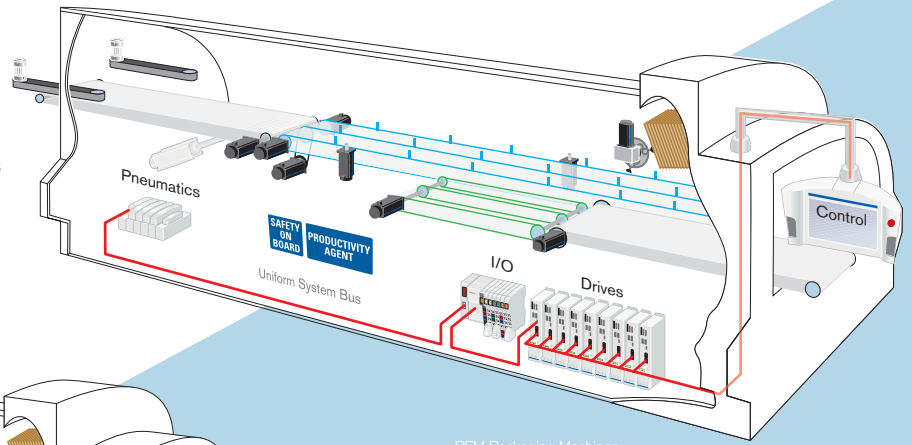

- Doeffler Engineering
- Dopaco
- Dorman & Associates
- Douglas Machine
- Doyen Medipharm
- DSI Stein
- Dyna-Pak
- E+K Sortiersysteme
- Eagle Machinery
- Edson
- Elbag AG
- Elliott
- EmBeWe GmbH
- Emerald Packaging
- Emkon Systemtechnik
- ERCA
- Ets JR Maruani
- EUROline
- Evergreen Packaging
- EVG Herрман GmbH
- Fabrima Maquinas
- FAES
- Fallas
- Fameccanica Data S.p.A.
- FIFE Machine
- FIMA
- Fin-kon Polybag Systems Ltd.
- Finnah Engineering
- Flouren Elektro-Technik GmbH
- FMC
- FMS
- Focke
- Food Machinery Sales
- Fopac
- Form Tight
- FPS Technologies
- Franke & Pahl
- Franz Haas
- Franz Haas Waffelmaschinen
- Frazier Nash
- Fröhlich
- G & O
- G.D. Sp.A.
- G.I.E.M.

- Gabler Maschinenbau GmbH
- Gebr. Dabrock GmbH
- Georgia Packaging
- Gerd Gillenkirch GmbH
- Gevas
- Gieffe Sr.l.
- Glaces Thiriet SA
- Glass Horst
- Gloucester Engineering
- GN Packaging
- GN Plastics
- Goldco
- Görig
- Gram A.S.
- Graphic Packaging International
- Green Bay Engineering
- Gundlack
- Günther
- Hagemann GmbH & Co.
- Handtmann Albert GmbH & Co. KG
- Harken
- Hartness
- Hassia
- Hassia-Redatron GmbH
- Hatec Hannover Technology
- Hauni Maschinenbau AG
- Haver & Boecker
- Hayseen
- Hegla
- Herlitzius Schneidetechnologie
- Hermann Waldner GmbH
- Hitech Systems Sr.L.
- HK Systems
- HMR
- Holmatec Maschinenbau
- Hood Packaging
- Hooper
- HOSOKAWA BEPEX
- Hötten Maschinenbau
- Hudson-Sharp
- I.M.G. srl
- IASE
- IDG S.P.A.
- IMA S.p.A.
- IMA tec s.a.r.l.
- Impress USA
- Integrated Design Corp
- Integrated Packaging Systems

- International Thermoforming System
- IPACT
- IPS
- Irwin Intl
- Irwin Research
- Ivex Packaging
- J & C Automation
- J & L Development
- J. Affeldt
- JCEM GmbH
- JLS Automation Robotics
- Jointech
- Joong Ang Engineering
- Kaman Industrial Technologies
- Karl Schnell GmbH & Co.
- Kauffman Engineering
- Kettner GmbH
- KHS
- KHS Fillers
- Kisters
- Kisters Kayat
- Kisters Maschinenbau GmbH
- Kliklok
- Klöckner Bartelt
- Klöckner Hänsel
- Klöckner Medipak GmbH
- Klöckner Pentaplast
- KMB Produktions AG
- Koch Maschinenbau
- KPC
- KPL Packaging Sp.A.
- Kraemer & Grebe GmbH & Co. KG
- Kraken Electric
- Krause Automatisierungstechnik
- Krausopf
- Krones AG
- L & H Technologies
- Langen
- Laudenberg GmbH
- Leading Edge Technology
- Lebenstedt GmbH & Co. KG
- LEKO-Verpackungstechnik GmbH
- Lewis Supply
- Lieder Maschinenbau
- Linpac Packaging
- Lorma Automation

- Lyle Machinery Company
- MAF Verpackungstechnik GmbH
- Maier Packaging GmbH
- Makat Candy Technology
- Malek Brautech
- Maschinenbau Runkel GmbH
- Massman
- Mateer Burt
- MCAP Cable & Glassfiber
- Mead
- Meypack
- MGS
- Modern
- Mohrbach Maschinenfabrik GmbH
- Mopac Modern
- Morrell
- Nagrelli
- Nappo
- NATEC
- NBTY Capsuleworks
- Nematec
- Nercon Engineering
- New Jersey Machine
- Nordson
- Norwalk
- Novakust Pexco
- Nudawn
- O.T.E.M.-PAK 2K Sr.L
- OMB di Bernasconi
- O-Mega Packaging AG
- OPM Sp.A.
- Optima
- Optipack GmbH
- Orbit Motion
- Osgood Industries
- Packaging AG
- Packaging Systems Automation
- Packaging Technologies
- Pactiv Corp
- Paper Converting
- Par Systems
- Pasteur Milk Co., Ltd.
- Paul Hartmann AG
- Peerless
- PDC International
- Peerless
- Pemco
- Perini
- Pester Pac Automation
- Peters Machinery

- PFM Packaging Machinery
- Phoenix Automation
- Pillsbury
- Plastipak Packaging
- Polarcup
- Polyair Packaging
- Powis
- Prairie Packaging
- Precision Packaging
- Printpack
- Progressive Technology
- Promera
- Prometco
- Pro-pac
- Prototype Equipment
- Proven Design Inc.
- Proven Designs Inc.
- Province Automation
- PSA
- RA Jones
- RA Pearson
- Racupack B.V.
- Rapidac
- Rapidpak
- Raque Foods
- Raymond
- Rhino Assembly
- Riemelt Engineering
- Ring Container Technologies
- Riverwood
- Riverwood GmbH
- Riverwood International Sp.A.
- Ro-An
- Robert Bosch GmbH
- Roberts
- Robox
- Ropak
- Rotzinger AG
- Rovema
- Rowa GmbH & Co. KG
- Sage Automation
- Samas
- Sammontana Sr.L
- Sandvik Process Systems GmbH
- Sartorius India PVT. LTD.
- Sassib
- Schäfer & Flottmann
- Schmalbach-Lubeca AG
- Schneider Packaging
- Schubert Gerhard GmbH
- Seckinger Automation
- Selcom Elettronica
- Sema GmbH
- Sencorp Thermoformers
- Serpa
- SFM SA
- Shanklin
- Sheffield Plastics
- Sherwood Tool
- Siesgsmund & Co. OHG
- SIG Asbfill GmbH
- SIG Combibloc GmbH & Co. KG
- SIG Combibloc Ltd.
- SIG Hamba Filter GmbH & Co. KG
- SIG Pack Systems AG

- SIG Sapal SA
- SIG Transer AG
- Simonetti
- Slidell Inc
- Smurfit Stone
- Solbern
- Sollich GmbH & Co KG
- SOMIC GmbH & Co. KG
- Sortimat Technology
- Spee-Dee Packaging
- SpeMaBa
- Steuerungstechnik Kraft GmbH
- Stoelle
- Stomax
- Sunoco Packaging
- Superior
- SWF Salwasser
- Synchrosys
- Tacom SA
- Tanney
- Tazzari GL
- Technistar
- Teepack GmbH & Co. KG
- Tenneco Packaging
- Terumo Medical
- Tetra Pak
- Tevopharm
- Thermoforming Systems
- Thiele Technologies
- Thom Metall- und Maschinenbau
- Tipper Tie
- Tisma
- TPS International
- Triangle Packaging
- Uhlmann Pac-Systeme
- Ultra Pac
- Unitherm Food Systems
- Utomatisierungsges GmbH
- V.A.C. Machines BVBA/SPRL
- Van Leer Verpackungen
- Vanpac
- Vector Logic Inc
- VG Nicolaus GmbH
- Vire Sr.L
- Vortex Systems S.R.L
- VT Process Technology
- W. Kopp Maschinenbau
- Wächter Packautomatik
- WAS Weber Automation
- WCB
- Weckerle GmbH
- Weldun
- Westfalia Separator Food Tec
- WF Wilhelm Fischer
- Wilton Connor Packaging
- Winkler und Dünnebier
- Winpak Lane
- Wolfgang Buerk
- Wolverine Tube
- Wonder Pack Industries PVT LTD
- Wornick
- Wrabacon
- Wright Industries

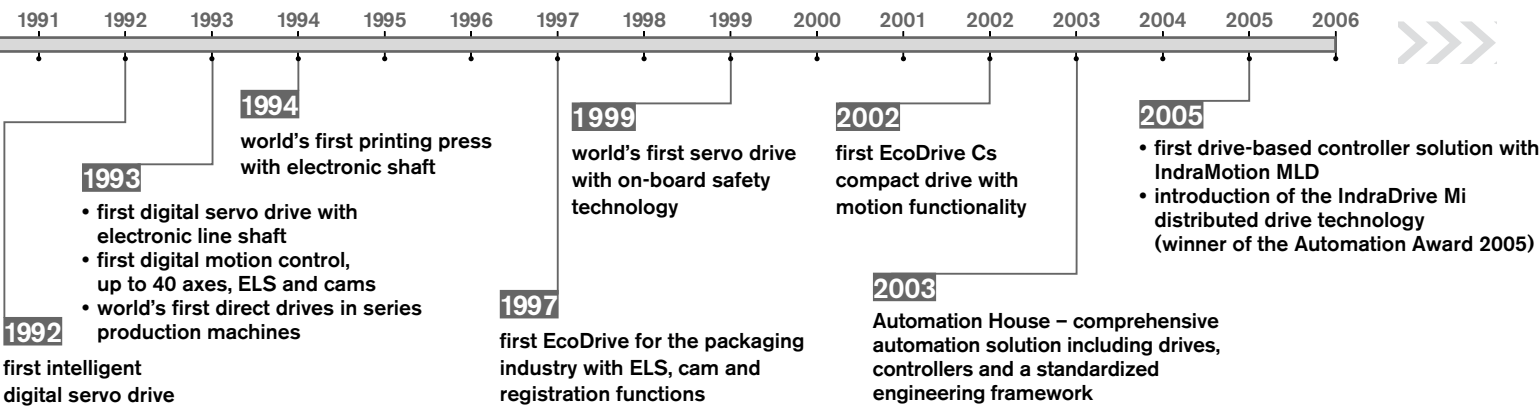

Bosch Rexroth AG
Electric Drives and Controls
P.O. Box 13 57
97803 Lohr, Germany
Bgm.-Dr.-Nebel-Str. 2
97816 Lohr, Germany
Phone +49 9352-40-0
Fax +49 9352-40-4885
www.boschrexroth.com

Presented by:

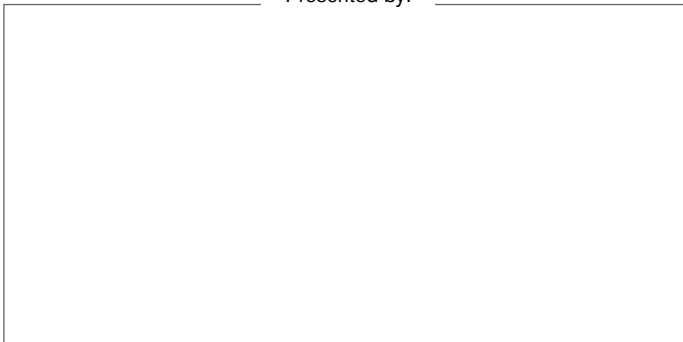

The data specified above only serve to describe the product.
As our products are constantly being further developed, no statements concerning a certain condition or suitability for a certain application can be derived from our information. The information given does not release the user from the obligation of own judgment and verification. It must be remembered that our products are subject to a natural process of wear and aging.

71 245 AE/06-11 – A1 – HW
R911318188
© Bosch Rexroth AG 2006
Subject to revisions!
Printed in Germany