

IndraMotion MTX

The CNC system solution for perfect cutting and forming



IndraMotion MTX – high-speed CNC machining

The market for CNC machine tools is characterized by high variability and demand for control and drive solutions which meet user expectations both in job shops and in automated, large-scale production environments. We have created one of the most advanced CNC platforms: IndraMotion MTX, completely covering this wide range of applications.

Whether you want to automate a production machine for cutting or forming applications or control a networked system for large-scale production, the IndraMotion MTX will provide you with the perfectly matched solution.

Features of the system include:

- ▶ outstanding performance
- ▶ scalable performance and functionality
- ▶ simple operation and programming
- ▶ a full-featured engineering framework
- ▶ open system architecture

Thanks to the modular design of hardware and software, the IndraMotion MTX is excellently suited for integration into a wide range of machine designs.

A wide range of technology functions and outstanding performance characteristics open up new possibilities in the areas of:

- ▶ turning
- ▶ milling
- ▶ boring
- ▶ grinding
- ▶ bending
- ▶ nibbling
- ▶ punching
- ▶ shape cutting
- ▶ handling



▲ **Highest productivity and energy efficiency for cutting and forming with IndraMotion MTX**

Versatile platform

An innovative CNC kernel, comprehensive libraries and technology packages provide flexibility for applications ranging from standard machines to fully-automated production systems.

Easy-to-use

User-friendly operating software, a full-featured engineering framework and integrated web technology simplify programming, operation and diagnostics.

Outstanding Performance

Shortest CNC cycle times and minimum PLC processing times permit high-speed, dynamic machining and reduced non-productive times for significant increases in productivity.

High-precision machining

A high performance CPU, in conjunction with the intelligence of Rexroth's IndraDrive system, delivers very high precision in all of your applications, even those in the nanometer range.

A complete solution with integrated cycles and high-end technology functions ensures standardization of your machines and allows you to implement special, machine-specific functions.

Open architecture

The open system platform uses international industry standards such as Ethernet, OPC server, sercos, EtherNet/IP and PROFINET, facilitating integration into higher-level ERP systems like SAP.



Faster production with outstanding performance

You can use the IndraMotion MTX to perform simple, effective control of standard machines for milling, turning, drilling, grinding, nibbling, punching, blanking, or bending operations.

Milling – fast and effective

The CNC functions, which have a proven track record in practical application, cover the entire spectrum ranging from standard milling machines to HSC centers for free-form machining.

Even comprehensive programs can also be executed easily and without delay via hard disk or network access.

The open system architecture allows CAD/CAM and customized software packages to be conveniently and seamlessly integrated for creating part programs.

- ▶ axis-specific jerk limitation
- ▶ 1,000 NC blocks with look-ahead function
- ▶ Spline interpolation
- ▶ B-spline compressor
- ▶ nano interpolation
- ▶ 5-axis machining
- ▶ 3D cutter radius compensation
- ▶ turning, on milling machines
- ▶ Ethernet for DNC

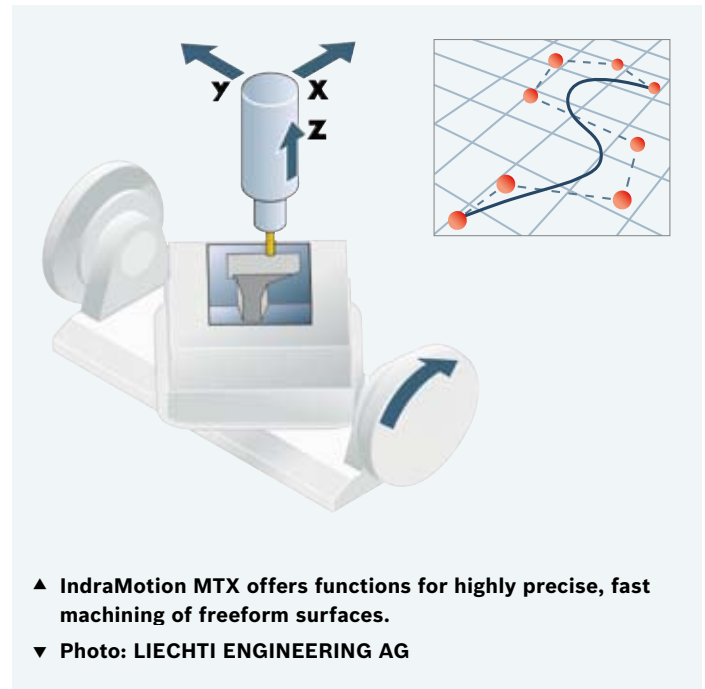

Complete, precision lathe operations

Modern turning centers can turn, drill, mill, cut and more. Workpieces can be efficiently and precisely machined in one clamping by combining different machining technologies in a single process.

IndraMotion MTX offers you all the functions and capabilities for dynamic turning and more: all the way to cross-technology, multi-axis machining.

Multi-channel capability and axis transfer between the channels allow you to perform machining on the reverse side with workpiece transfer on multi-spindle lathe centers.

- ▶ C-axis machining with driven tools
- ▶ cylinder jacket machining
- ▶ end-face machining
- ▶ multi-channel machining
- ▶ unrestricted axis transfer between the channels
- ▶ spindle coupling
- ▶ electronic transmission
- ▶ any combination of machining technologies in a single process

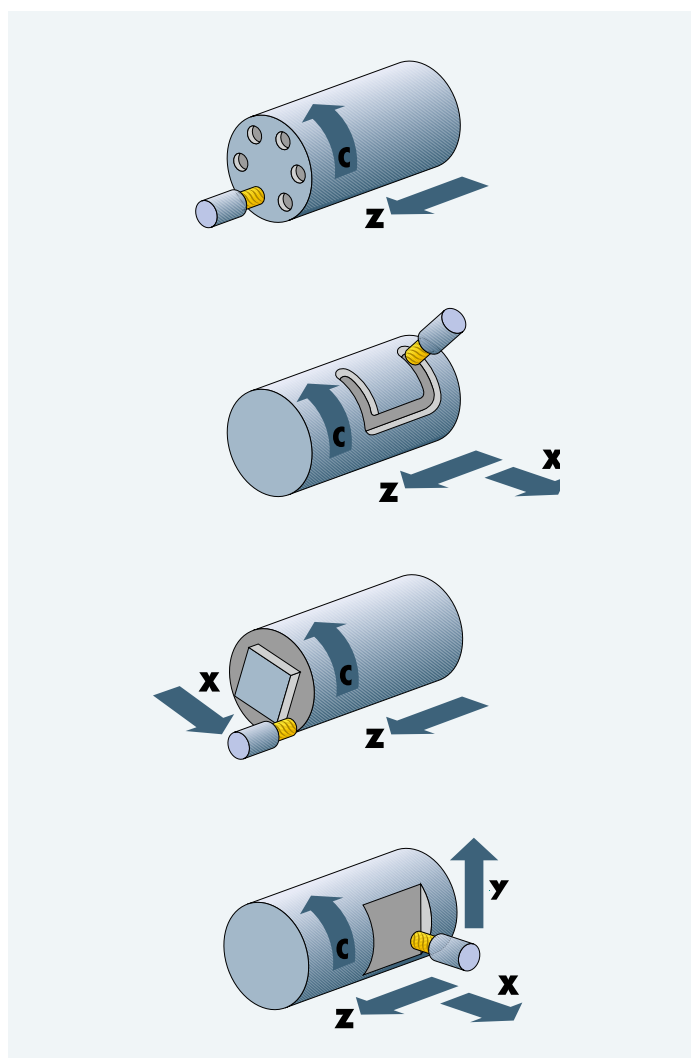

- ▲ Complete machining, from turned parts with boring and milling functions to cylinder jacket and end face machining.

Greater precision with more technology

Grinding – high dynamics with nano precision

IndraMotion MTX with Rexroth's intelligent IndraDrive digital drives and IndraDyn motors are the ideal solution for your demanding grinding applications, offering precision in the nanometer range. The individually scalable CNC platform with integrated PLC ensures ultra-fast response to process events and minimizes downtime.

- ▶ integrated transformation for inclined axes
- ▶ minimum CNC interpolation time of 0.25 ms
- ▶ nano interpolation
- ▶ linear direct drives have excellent dynamic characteristics
- ▶ high-speed I/O in the interpolator cycle
- ▶ easy customization of the standard operator interface

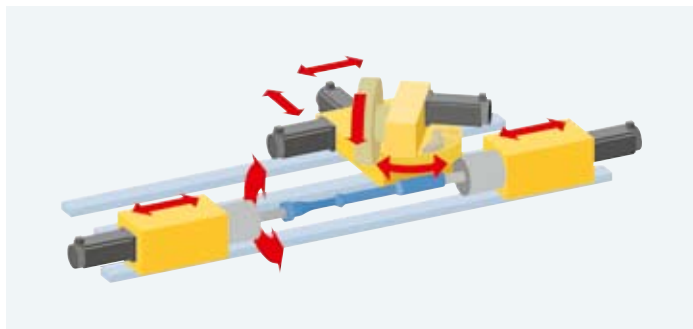

Blanking – precision and speed

IndraMotion MTX provides optimal control for plasma, laser and water-jet cutting machines thanks to ultra-fast response times and superior speed guidance. Programming becomes easy and efficient – even for difficult tasks – with the process-optimized control functions.

- ▶ reversing over the contour with retrace
- ▶ axis coupling and gantry operation
- ▶ speed-dependent power control
- ▶ high-speed I/O in the interpolator cycle
- ▶ fast distance control
- ▶ spline interpolation
- ▶ 5-axis machining
- ▶ standard interfaces for CAD/CAM connection

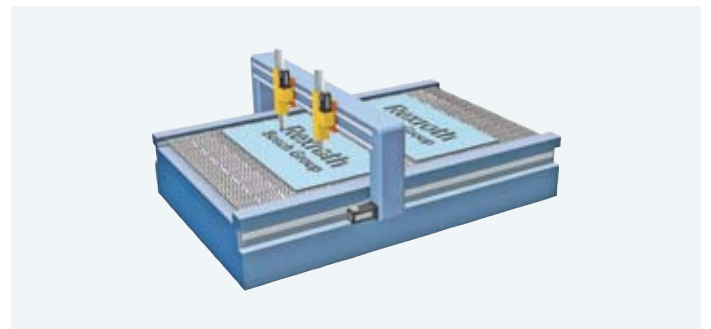

Nibbling and punching – fast and accurate

IndraMotion MTX and IndraDrive digital drives allow you to maximize the stroke rate of your machine and improve productivity. A process-optimized operating interface and special punching and nibbling functions of the CNC core facilitate programming and reduce machining downtime.

- ▶ fast stroke activation from the CNC core
- ▶ tangential tool guidance
- ▶ high-speed I/O in the interpolator cycle
- ▶ fast distance control
- ▶ robust control hardware designed for industrial environments
- ▶ electro-hydraulic punch axis

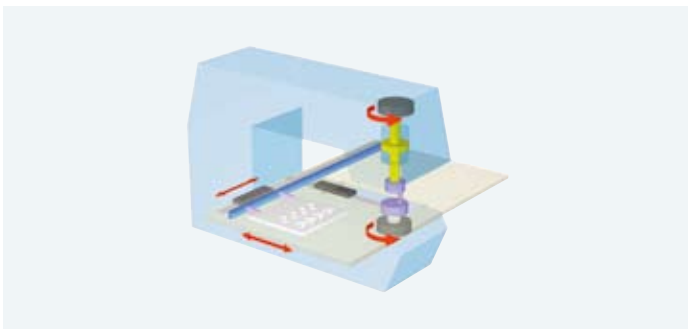

Bending – coordination and high precision

The IndraMotion MTX consistently bends sheet metal, pipe, profiles or wire with a high degree of geometrical precision. You can use axis interpolation with up to 8 axes on one CNC channel to achieve perfect operations such as 3D bending. You can combine Rexroth hydraulic and electro-mechanical CNC axes any way you like using the sercos interface to achieve optimal process adaptation.

- ▶ exact motion coordination in space
- ▶ axis transformation for easy programming
- ▶ standard interfaces for CAD/CAM connection
- ▶ intelligent-, hydraulic-axis controls
- ▶ interpolation between hydraulic and electrical axes
- ▶ high performance digital drives
- ▶ SafeMotion for integrated safety functions with ultra-short reaction times

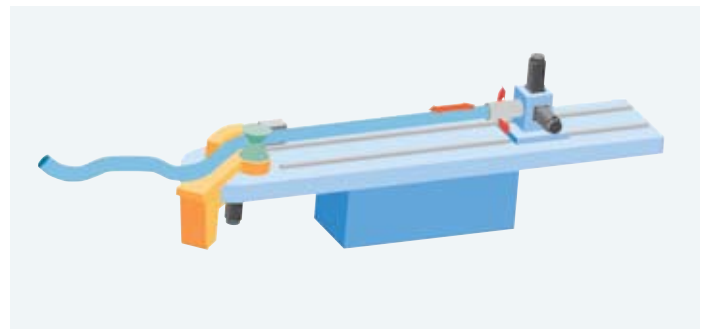

Ease of operation and visualization

The CNC operating interface of IndraMotion MTX is fast and easy to use. All operating areas are clearly structured with standard screens to provide a good overview of the machine status. Exceptional processes are also visualized in a clear manner thanks to extensive expansion options for plant or process-specific special images.

You can make use of a complete, full-featured software package that takes you from project planning and commissioning right through to part programming. User interfaces designed with practical application in mind increase productivity and simplify troubleshooting, providing greater transparency in your systems and processes.

The program user interface assists the operator in all tasks by providing intuitive dialog screens for:

- ▶ setting up the machine
- ▶ preparing tools
- ▶ creating and executing CNC programs
- ▶ changing parameters
- ▶ diagnosing problems
- ▶ online switching between numerous languages



- ▶ **User panel variants**
 - keys with 30.5 cm (12") display
 - combined key or touchscreen operation with 38.1 cm (15") display
 - touchscreen operation with 48.3 cm (19") display



Efficient programming

The custom operator panels combine all functions – from visualization to machine operation and programming – in a single unit. Optimal coordination of hardware and software facilitates clear diagnoses and enables fast, efficient operation.

Robust panel in IP54 aluminum variant

Soft keys for selecting machine functions such as subordinate operating modes or motion triggering

Context-sensitive softkey menu with operating mode functions

Softkeys for selecting unique operating modes

USB port (IP54)

Emergency stop

4-step key-operated switch

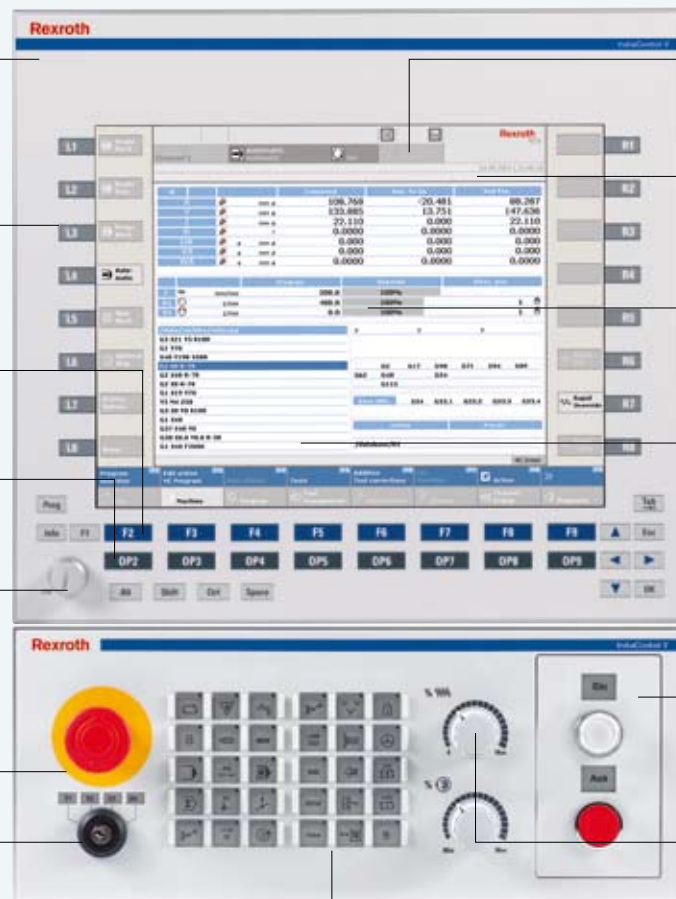

Diagnostic header displays system status via icons and messages in plain text

Rolling display of current diagnostic texts: clear identification by message, warning, or fault

CNC main screen with display of process data such as axis position, program and active M and G codes

CNC parts program display with program progress indicator and syntax highlighting

Optional configuration with start/stop button or installed handwheel

Spindle and feedrate override

30 freely programmable and markable PLC buttons

Efficient programming Cycles – parameterization instead of programming

IndraMotion MTX has a comprehensive technology-cycle library for standard machining. Cycle selection, parameter entry and clearly arranged dialogs are all easy thanks to the intuitive user guidance. Complex machining tasks are easy to carry out, which improves efficiency and helps to avoid errors.

Cycle examples

Turning



Drilling

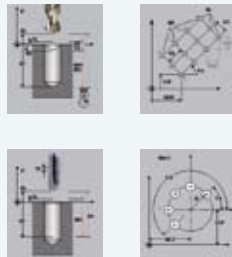

Milling

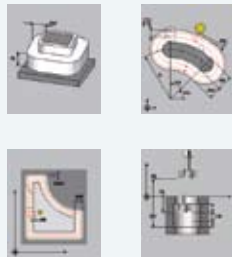

Contouring

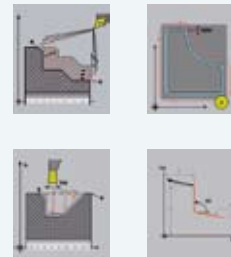

Engraving



Cycle input screen

Graphical assistance for every parameter

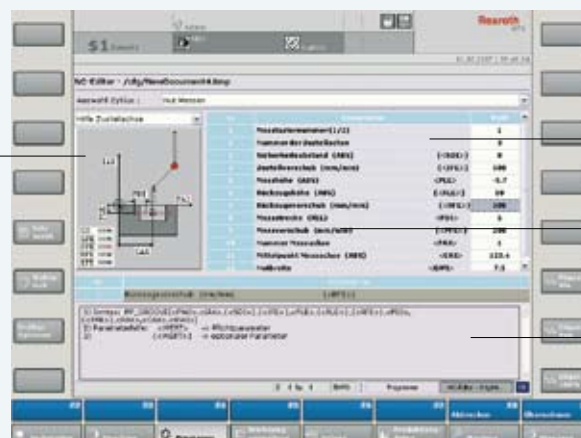

Brief description of parameter

View optional parameters for experts

Plausibility check of parameters entered

Tool input screen

The tool management facility is easy to use and can be adapted to different types of machine and magazine. Screens for entering tooling data and providing overviews of tool lists with wear status, for example, are part of the standard screens..

- ▶ up to 999 tools, 16 cutting edges per tool
- ▶ geometry and wear corrections
- ▶ tool life management
- ▶ radius correction, tool edge correction
- ▶ angle head tools
- ▶ fixed-place coding/variable coding
- ▶ alternate tools
- ▶ configurable tooling database

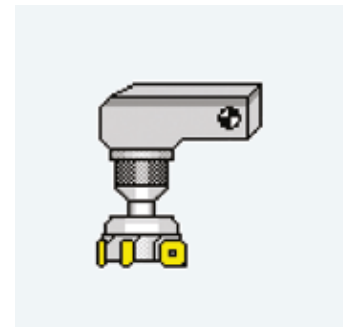
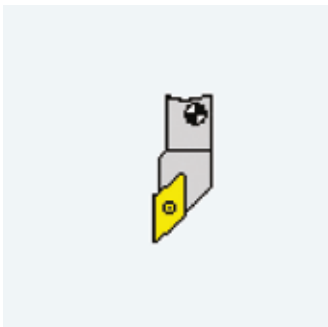
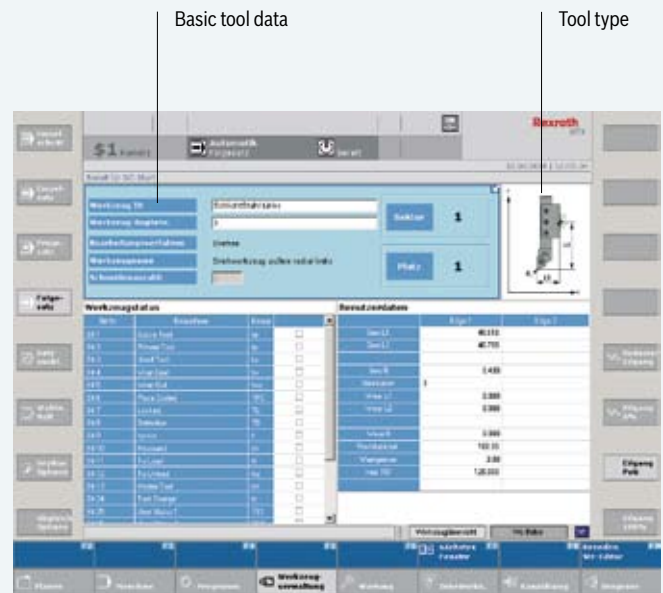

Perfect 3D simulation

The optional NC simulation visualizes parts programs in parallel and entirely independently of machining time. This allows idle times to be used to prepare for the next production job. The multi-window 3D display shows the machining process and possible tool collisions. Programming errors are thus detected in good time and easily corrected.

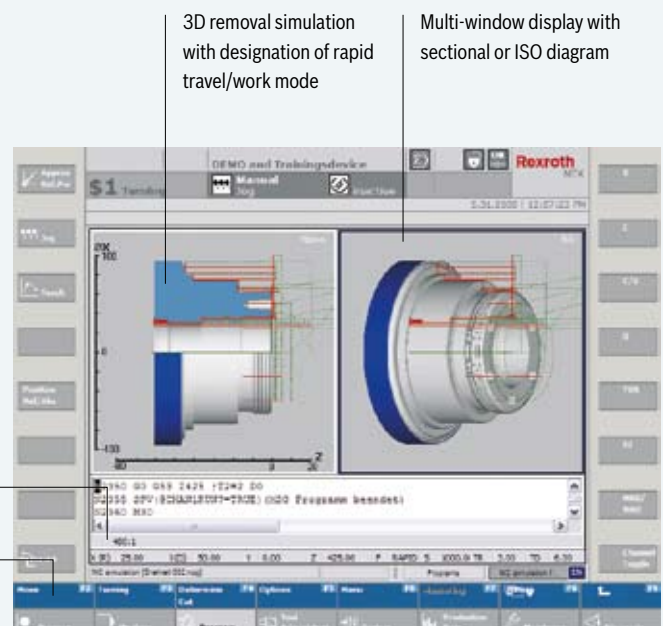

Display of program processing

Start, stop and individual axis control via soft keys

Simulate perfectly, design efficiently

Simulation tools help programmers to program systems more efficiently and to test and optimize automation projects before they even leave the office.

IndraMotion MTX simulator

The IndraMotion MTX simulator software tool offers the complete project planning environment and operating interface of the IndraMotion MTX system. A complete package for standard PCs comprised of a virtual CNC and PLC core, original CNC screens and virtual VAM simulator machine user panel which can be used both as an engineering workstation and as a training system – without additional hardware.

IndraWorks view 3D

An optimum supplement to the IndraWorks engineering environment, the IndraWorks view 3D simulation tool provides you with the means of visualizing machine kinematics in accordance with assigned process variables.



IndraWorks machine simulator

With the IndraWorks machine simulator, available as optional add-on software, IndraWorks can simulate the machine's peripherals – such as sensors and actuators – on PROFIBUS. As a result, it's possible to create models of plant components or even complete machines and archive them in a modular system.

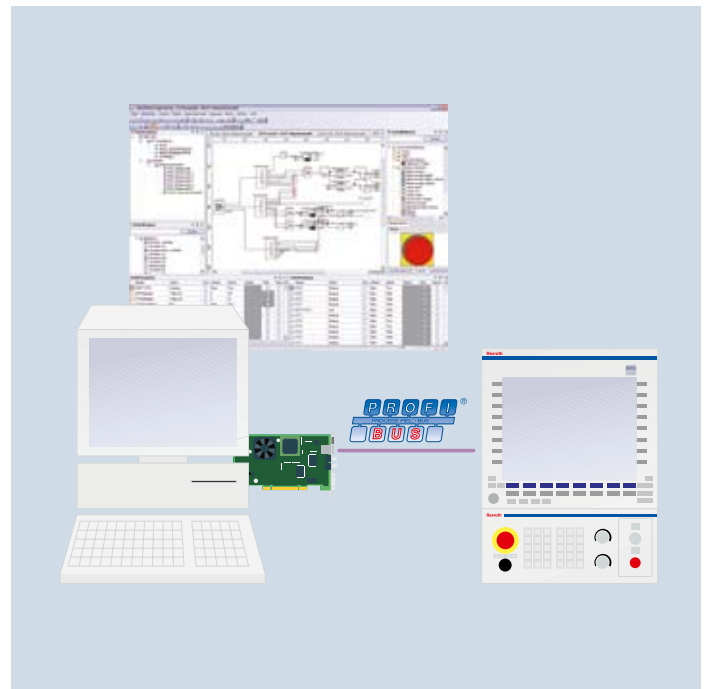

Direct communication

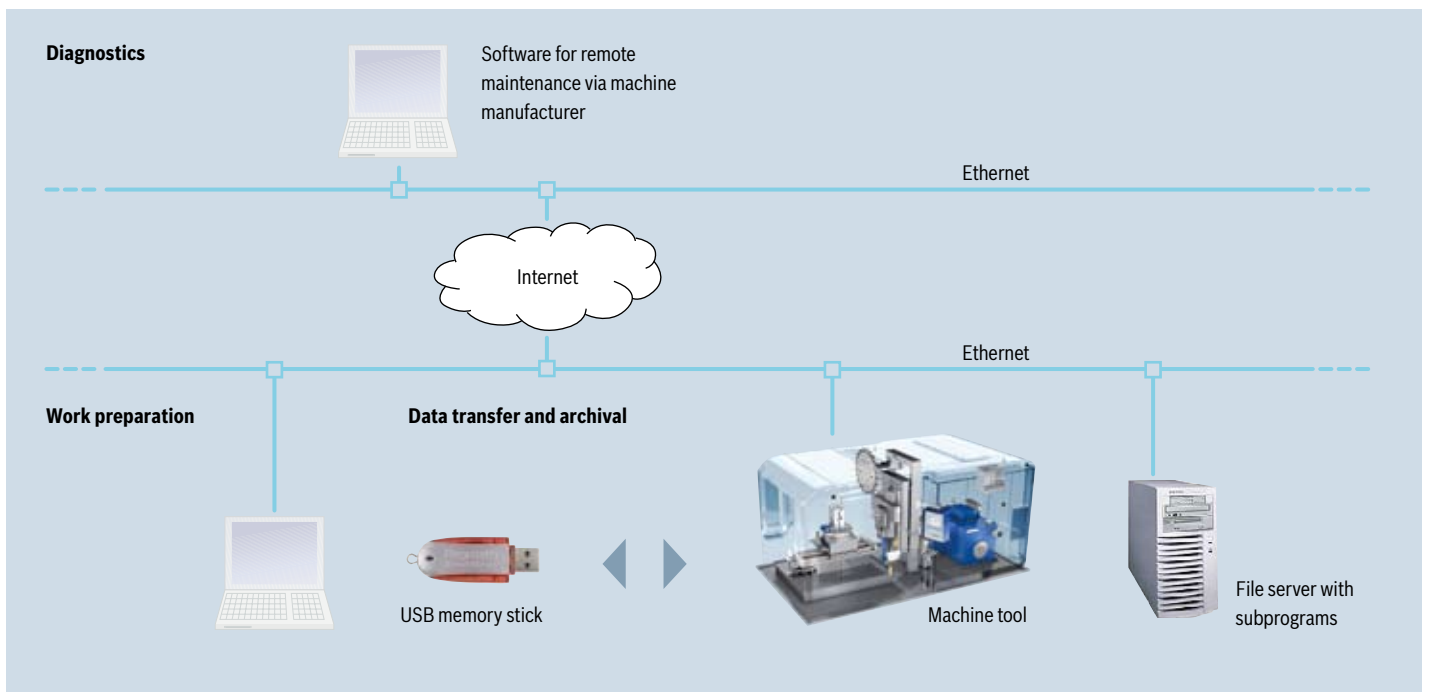

Program processing over the network

- ▶ easy integration of IndraMotion MTX in existing network infrastructures via Ethernet and TCP/IP
- ▶ almost unlimited storage space for NC programs and data
- ▶ slim transfer protocol ensures fast data transmission
- ▶ seamless integration of external CNC data in the IndraMotion MTX file system via network drives

Remote maintenance and diagnostics

TCP/IP communication allows a connection to be made to an office PC and CNC control system. This, in turn, makes it possible to carry out diagnostics from a control station or even perform remote maintenance over the Internet.

▲ Integration of IndraMotion MTX in existing network:

- remote maintenance over the Internet
- program processing over the network
- backups or program processing using a USB port

Program processing via external storage media

- ▶ a USB port on the front of the control panel can be used to connect external storage media such as a USB stick.
- ▶ integration of storage media in the file system of the control enables direct selection of CNC programs (copying not necessary).

Efficient engineering cuts time to production

The engineering tool IndraWorks carries you confidently through all the steps in project planning, programming, parameterization, operation and diagnosis.

An engineering tool for all tasks

You can take advantage of cross-system project management and central data storage to organize large-scale automation projects in an efficient format that is easy to understand. Commissioning functions for the parameterization and optimization of IndraMotion MTX systems are started centrally from IndraWorks.

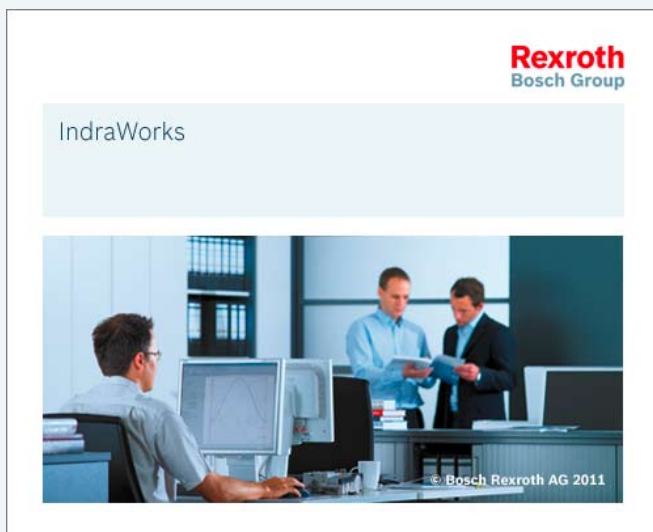
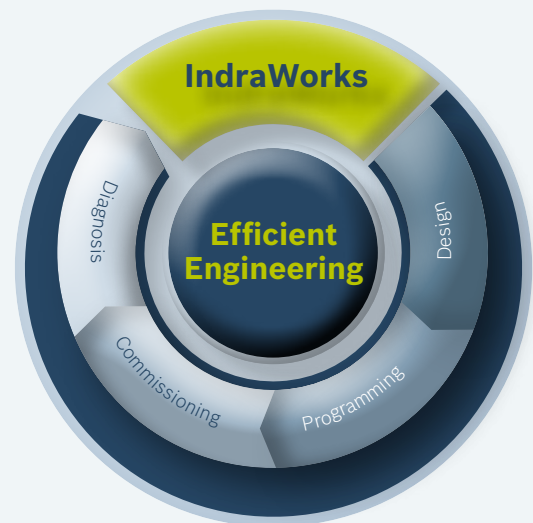

IndraWorks – task-oriented operation and visualization

PLC programming and commissioning

The integrated IEC 61131-3 compliant PLC lets you program using instruction lists, functional block diagrams, ladder diagrams, structured text, or sequential language.

Configuration tools for fieldbus communication are also part of the scope of functions, as are error diagnostics functions for servicing or commissioning.

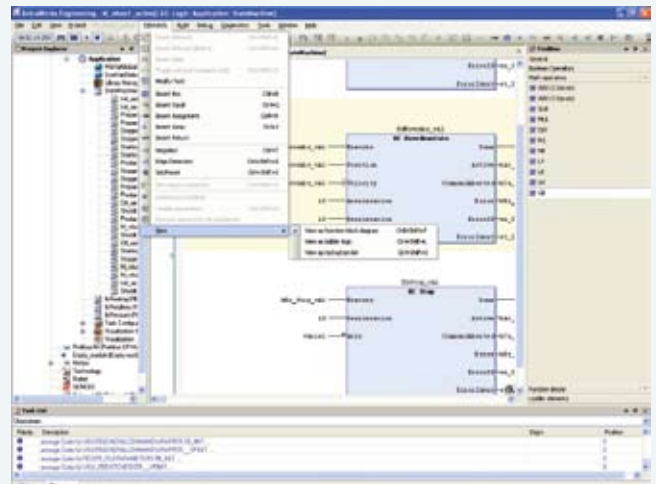

Integration of system-specific custom images

The integrated WinStudio HMI editor creates system-specific custom images that are integrated seamlessly in the standard interface. This makes it possible to create system overview images and to visualize process status effectively. WinStudio can also be used to create special operation screens for machines or high-volume production, for example.



Optimized processes with IndraMotion MTX efficiency workbench

IndraMotion MTX efficiency workbench is the platform for versatile tools that improve machine and system efficiency. The universal efficiency tools can be used to optimize the productivity and energy efficiency of machine tools.



Cycle time analysis tool IndraMotion MTX cta

IndraMotion MTX cta makes it easy to understand complex machine tool processes. Optimization potential of NC programs and process variables is quickly and easily identified, cycle times are minimized and productivity improved.

Advantages

- ▶ process optimization and elimination of bottleneck situations thanks to synchronized recording of CNC, PLC and drive signal data down to the millisecond
- ▶ easy handling of data via table-based and graphical depiction of measurement results
- ▶ optimization of sub-systems such as material feeders or tools changers for production machines or of machining programs for mass production



IndraMotion MTX ega energy analysis tool

The energy consumption of machine tools is influenced by many factors, including process sequence, tool wear and raw material tolerances. With IndraMotion MTX ega and the integrated energy monitor, an overview of the machine's energy consumption is provided at the press of a button.

Advantages

- ▶ transparency of energy requirements as the basis for improved energy efficiency for all CNC machining technologies
- ▶ differentiation between machine modules
- ▶ simultaneous analysis of cycle time and energy requirements

System status always in view with IndraMotion MTX rcm

IndraMotion MTX rcm, the remote condition monitoring system, allows you to centrally save and monitor measured values from networked systems. Process-specific evaluation methods facilitate maintenance and increase system availability.



Remote condition monitoring system IndraMotion MTX rcm

IndraMotion MTX rcm regularly monitors measured values, and integrated evaluation methods make it possible to detect damage and wear early on. This reduces inspection and maintenance effort and increases availability. Special measuring processes are controlled by the CNC control. The intelligent automation components, such as the Indra-Drive controllers, provide meaningful data without additional sensors required – a cost-effective solution.

Advantages

- ▶ machine status always available at the press of a button
- ▶ automatic text (SMS) or e-mail notification
- ▶ communication via standard Ethernet interface for the machine controllers
- ▶ data collection on a local SQL server
- ▶ easy access for visualizing and evaluating via the standard Web interface
- ▶ technological advancement with industry and manufacturer-specific testing methods
- ▶ open for third-party systems via universal XML interface

Rexroth service specialists assist you during installation and commissioning.

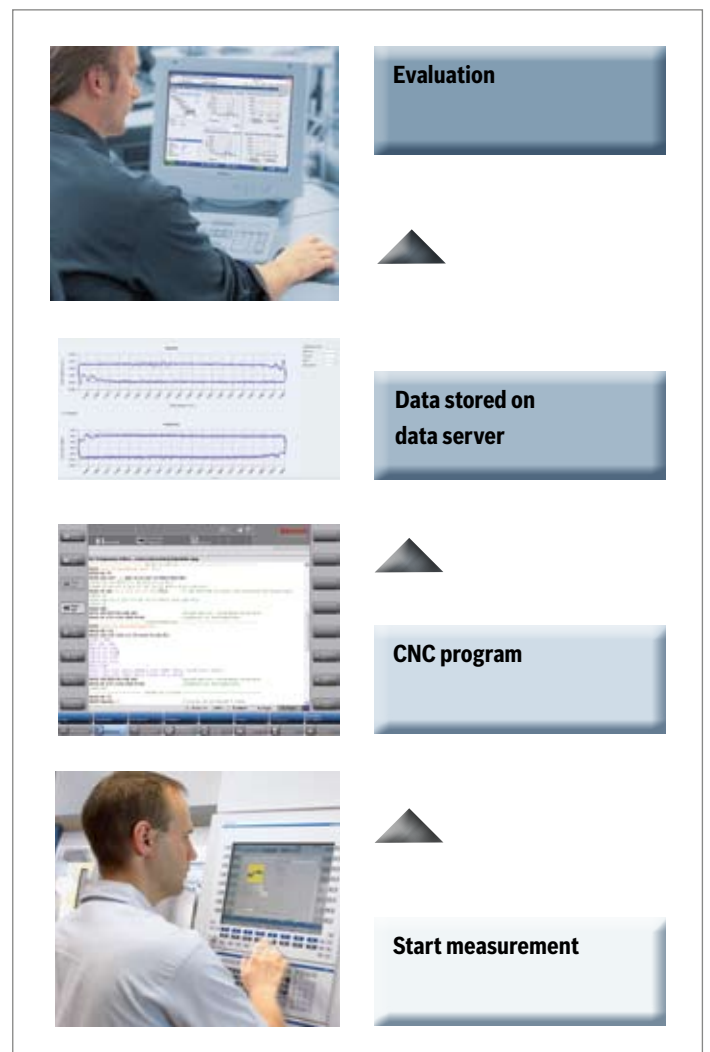

Integrated communication at all levels

IndraMotion MTX is a complete building system that we use to develop customized CNC solutions for your application – whether you are looking to automate a series machine or a complex high-volume production system.

IndraMotion MTX incorporates a modular system design, open controller structure and standard international interfaces to solve all of your machining tasks in the field of CNC technology with the highest level of dynamics and precision.

Host computer level

Our industrial PCs provide a simple and cost-effective communications path to host computer systems. The system is based on standard industrial hardware and software such as Ethernet TCP/IP and OPC.

HMI level

PC-based operating devices simplify data exchange by using standard networking such as the Microsoft network.

I/O level

We use global standards such as sercos, PROFIBUS, PROFINET and EtherNet/IP for communicating at the sensor/actuator level.

Drive plane

The internationally standardized sercos interface is used to achieve the highest level of dynamics and precision. IndraMotion MTX and IndraDrive fully exploit the advantages of the sercos interface with data transfer rates of up to 100 MBaud.

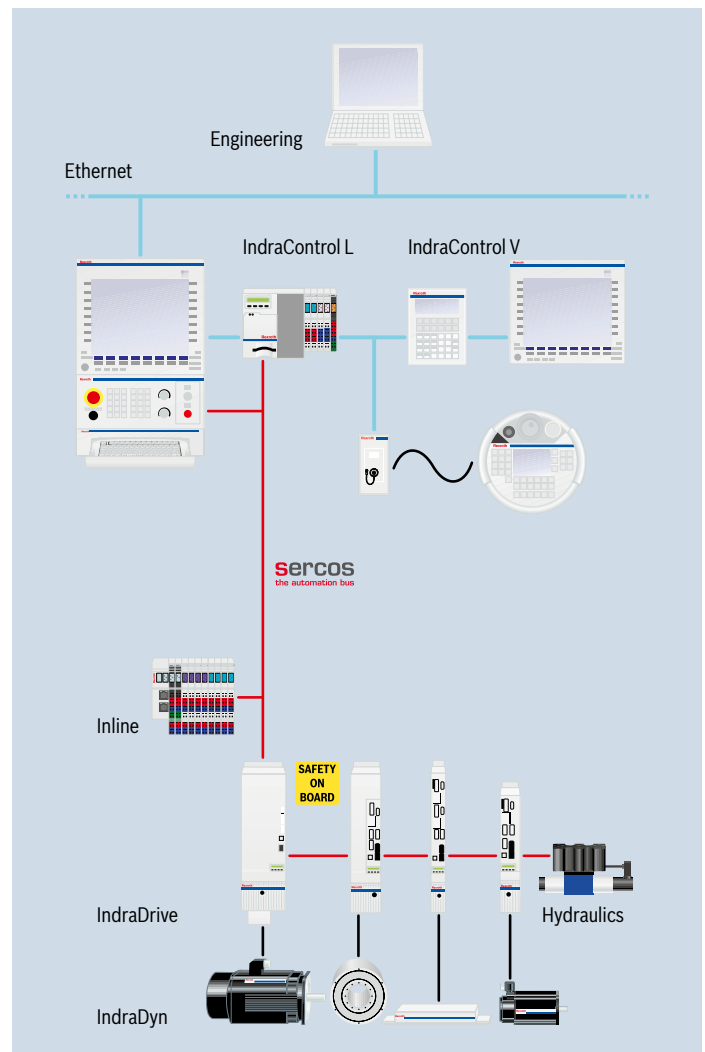

**IndraMotion MTX standard with complete CNC
IndraControl L45**



**IndraMotion MTX performance with complete CNC
IndraControl L65**



**IndraMotion MTX advanced with complete CNC
IndraControl L85**



Uniform hardware and software makes IndraMotion MTX individually scalable in performance and functionality. The variants available leave nothing to be desired:

**IndraMotion MTX standard –
universal CNC control**

A complete CNC with integrated PLC for DIN rail mounting characterizes this control. This basic version offers outstanding performance for 8 axes, of which 2 can be used for spindle functions in 2 independent CNC channels. The control is combined with the panels of the IndraControl V product family for operation and visualization.

**IndraMotion MTX performance –
high-performance CNC control**

IndraMotion MTX performance is the system solution for demanding machine tools used in rugged industrial environments. The control delivers excellent performance and offers a wide range of technology functions for special requirements. Twelve independent CNC channels can handle up to 64 axes, of which 32 can have a spindle function. A whole series of functions is available in addition for performing complex interpolation, axis coupling, special kinematics and fast I/O coupling.

**IndraMotion MTX advanced –
CNC control for the most demanding requirements**

Exceptional computing power through the use of state-of-the-art multi-core processors, masses of memory and the combination of high-performance, compact industrial PCs make IndraMotion MTX advanced the ideal system solution for particularly demanding applications. Twelve independent CNC channels can handle up to 64 axes, of which 32 can have a spindle function. The new high-performance CPU delivers minimal PLC and CNC processing times for outstanding productivity and precision.

Scalable system components for flexible automation

A controller-based control platform with exceptional performance, intelligent drive technology and performance visualization devices with a wide variety of accessories ensures ultra-high production accuracy in all applications.



IndraControl L – the controller-based control platform

- ▶ scalable hardware platform for central and distributed topologies
- ▶ highest performance in ultra-compact design
- ▶ maintenance-free design without fans or a hard disk
- ▶ large memory and CompactFlash for storage medium
- ▶ 8 rapid I/Os on board
- ▶ integrated standard interfaces such as sercos and Ethernet
- ▶ local connection of I/O inline modules without auxiliary couplers
- ▶ individual expansion using function modules for communication and technology



IndraControl V

IndraControl V

- ▶ comprehensive portfolio of HMI terminals for individual control, operation and monitoring in all segments of industry
- ▶ comprehensive line of controller-based devices, from compact embedded PC to high-performance industrial PC
- ▶ available with Microsoft Windows XP or Windows 7
- ▶ scalable hardware and software can be adapted to your exact, machine-specific requirements

IndraControl VCP and VCH – compact operating and visualization devices

- ▶ small, controller-based operator panels IndraControl VCP – graphics-capable versions with keys and touch-screen, display sizes 7.6 to 26.4 cm (3" to 10.4")
- ▶ robust IndraControl VCH manual operator panel for mobile applications, with maximum safety thanks to a 3-stage accept switch and dual-circuit stop button
- ▶ open Ethernet and fieldbus interfaces (type-dependent)
- ▶ ergonomic software tools for the fast generation of screens

IndraControl VAM – convenient machine control panels

- ▶ well thought-out operating concept for standard machine tools and automated manufacturing
- ▶ all user panels are designed specifically for the IndraControl V devices
- ▶ IP54 protection type
- ▶ control connection via sercos or PROFIBUS interface



IndraControl VAM



IndraControl VCP and VCH



IndraDrive and IndraDyn

IndraDrive and IndraDyn – the scalable drive platform

- ▶ compact drive converters and modular inverters for all applications
- ▶ scalable power components with continuous power of up to 120 kW
- ▶ scalable control units for cost-effective complete solutions
- ▶ highest performance and precision for all multi-axis applications
- ▶ safety on Board compliant with EN ISO 13849-1, Category 3 PL d and EN 62061 SIL 2 for STO and Safe-Motion
- ▶ certified safety technology for maximum personal protection; power contactors and speed monitors are no longer needed
- ▶ integrated line contactor and braking resistor
- ▶ easy to service and maintain
- ▶ integrated motion logic with PLC conforming to IEC 61131-3 is fully committed to open standards and makes it easier to implement customer know-how
- ▶ integrated, configurable technology functions on the basis of Motion logic for performing a wide and diverse range of process-oriented tasks
- ▶ sercos and PROFIBUS interfaces for communicating with the CNC and PLC control



Inline



IndraControl S67

Inline – flexible I/O system in IP20

- ▶ scalable I/O system for central or decentralized connection
- ▶ maximum channel selectivity of the digital modules with 2, 3 or 4-wire technology
- ▶ cost-effective solutions with block I/O modules
- ▶ wide range with analog, function, relay and feeder terminals
- ▶ space-saving design and toolless assembly
- ▶ flexible connection through permanent wiring and internal voltage supply
- ▶ fieldbus couplers for sercos and other fieldbus systems

IndraControl S67 – compact IP67 I/O system

- ▶ modular, ergonomic I/O system for distributed topologies
- ▶ wide range of I/O and technology modules and fieldbus couplers
- ▶ compact IP 67 enclosure
- ▶ cutting-edge hardware design supports maximum sensor and actuator signal processing speeds
- ▶ threaded or DIN rail mounting
- ▶ M8 and M12 signal line connections
- ▶ prefabricated fieldbus, power and subbus cables

Technical data

1	Machining technologies	MTX standard		MTX performance		MTX advanced	
1.1	Turning		●		●		●
1.2	Milling		●		●		●
1.3	Drilling		●		●		●
1.4	Grinding		●		●		●
1.5	Nibbling, shape cutting		●		●		●
1.6	Reforming		●		●		●
2	Axis control	MTX standard		MTX performance		MTX advanced	
2.1	Default number of axes	8	●	8	●	8	●
2.2	Max. number of axes	8	●	64	○	64	○
2.3	Max. number of spindles thereof	2	●	32	○	32	○
2.4	Default number of independent channels	2	●	3	●	3	●
2.5	Max. number of independent channels	2	●	12	○	12	○
2.6	Default number of interpolating axes per channel	4	●	4	●	4	●
2.7	Max. number of interpolating axes per channel	4	●	8*	○	8*	○
2.8	Linear axes		●		●		●
2.9	Rotary axes		●		●		●
2.10	Endlessly turning rotary axis		●		●		●
2.11	Hirth axes		●		●		●
2.12	Spindle/C-axis switching		●		●		●
2.13	Max. number of gantry groups per channel	4 ② ⑥	○	8 ② ③ ⑥	○	8 ② ③ ⑥	○
2.14	Channel-crossing axis transfer		●		●		●
2.15	Electronic cam		●		●		●
2.16	Spindle coupling via electronic transmission	⑦	○	⑦	○	⑦	○
2.17	Software limit		●		●		●
2.18	Axis-specific jerk limitation	① ②	○	① ② ③	○	① ② ③	○
2.19	achs-spezifische Ruckbegrenzung		●		●		●
2.20	Integrated safety functions according to EN ISO 13849-1 and EN 62061 (Safe Stop, Safe Motion)		□		□		□

● Default

○ Optional

■ Optional in connec. with a PC

□ Optional with IndraDrive

① “Turning 1” technology package

② “Milling 1” technology package

③ “Milling 2” technology package

④ “Turning” CNC simulation

⑤ “Milling” CNC simulation

⑥ “Shape cutting” technology package

⑦ “Electronic transmission” technology package

* An export license is required for this option. Per part I C of the export list (EC Regulation) item 2D002

3	Interpolation functions	MTX standard	MTX performance	MTX advanced
3.1	Linear interpolation	●	●	●
3.2	Linear interpolation with/without exact stop	●	●	●
3.3	Circular interpolation with radius and center-point programming, helical interpolation	●	●	●
3.4	Circular interpolation with tangential entry	●	●	●
3.5	Rigid tapping cycle	●	●	●
3.6	Thread cutting	●	●	●
3.7	Cylinder surface transformation	① ⑥	① ⑥	① ⑥
3.8	C-axis transformation	①	①	①
3.9	NC block preview, look-ahead	max. 1,000 blocks ●	max. 1,000 blocks ●	max. 1,000 blocks ●
3.10	5/6 axis transformation with TCP programming	–	③ ○	③ ○
3.11	Jogging with active transformation	–	③ ○	③ ○
3.12	Spline interpolation, C1 + C2, continuous cubic splines, B-splines, NURBS	① ② ○	① ② ③ ○	① ② ③ ○
3.13	Nanometer resolution	●	●	●
4	Feed functions	MTX standard	MTX performance	MTX advanced
4.1	Feed in mm/min or inch/min	●	●	●
4.2	Time programming	●	●	●
4.3	Feedrate per revolution	●	●	●
4.4	Constant cutting speed	① ○	① ○	① ○
4.5	Feed on positive stop	●	●	●
4.6	Torque reduction	●	●	●
5	Shifts and compensations	MTX standard	MTX performance	MTX advanced
5.1	Mirroring, scaling, rotating	●	●	●
5.2	Zero point offset	●	●	●
5.3	Korrekturen und Nullpunktverschiebung über CPL programmierbar	●	●	●
5.4	Placements (FRAMES)	② ○	② ③ ○	② ③ ○
5.5	2D compensation	●	●	●
5.6	3D cutter radius compensation	–	③ ○	③ ○
5.7	Compensation with plane switching	●	●	●
5.8	Tangential tool guidance	●	●	●
6	Tool management	MTX standard	MTX performance	MTX advanced
6.1	Integrated flexible tool management	●	●	●
6.2	Configurable tool database	●	●	●
6.3	Freely definable tool compensation (length, radius, cutting position compensation, user data)	●	●	●
6.4	Additive tool compensations (D compensations)	●	●	●
6.5	Access to tool data from PLC	●	●	●
6.6	Access to tool data from CNC	●	●	●

● Default

○ Optional

■ Optional in connec. with a PC

□ Optional with IndraDrive

① “Turning 1” technology package

② “Milling 1” technology package

③ “Milling 2” technology package

④ “Turning” CNC simulation

⑤ “Milling” CNC simulation

⑥ “Shape cutting” technology package

⑦ “Electronic transmission”

technology package

* An export license is required for this option. Per part I C of the export list (EC Regulation) item 2D002

7	CNC-Programmierung	MTX standard		MTX performance		MTX advanced	
7.1	Parts program development	DIN ISO 66025/ RS 274D	●	DIN ISO 66025/ RS 274D	●	DIN ISO 66025/ RS 274D	●
7.2	High-level language programming, CPL (customer programming language)		●		●		●
7.3	Graphical NC simulation	④ ⑤	○	④ ⑤	○	④ ⑤	○
7.4	CNC memory	256 MB		512 MB		1,024 MB	
7.5	Static memory	8 MB		8 MB		16 MB	
7.6	Max. size of parts program	PC hard disk (net- work file system)	●	PC hard disk (net- work file system)	●	PC hard disk (net- work file system)	●
8	Technology cycles	MTX standard		MTX performance		MTX advanced	
8.1	Drilling		●		●		●
8.2	Turning		●		●		●
8.3	Milling		●		●		●
9	Functions	MTX standard		MTX performance		MTX advanced	
9.1	Dwell time in seconds		●		●		●
9.2	Acceleration programming, loop gain programming		●		●		●
9.3	Homing through NC program		●		●		●
9.4	Absolute dimension, relative dimension		●		●		●
9.5	Switching between inch and mm		●		●		●
9.6	Probe, static/on-the-fly measurement		●		●		●
9.7	Read process and drive data through sercos		●		●		●
9.8	Roundings and chamfers		●		●		●
9.9	Corner rounding with splines		●		●		●
9.10	Laser power control		●		●		●
9.11	Digitizing		●		●		●
9.12	NC block defined by PLC		●		●		●
10	Support for control elements	MTX standard		MTX performance		MTX advanced	
10.1	Configurable operator screens		■		■		■
10.2	Cycle header/input support, OEM cycles		■		■		■
10.3	NC program restart/block search		●		●		●
10.4	Dry Run		●		●		●
10.5	Retracting from and returning to the contour		●		●		●
10.6	Retracting from and returning to the contour	⑥	○	⑥	○	⑥	○
11	PLC programming	MTX standard		MTX performance		MTX advanced	
11.1	Integrated PLC: IndraLogic		●		●		●
11.2	Programming languages according to IEC 61131-3 (IL, LD, CFC, ST, SFC, FBD)		●		●		●
11.3	PLC program memory	8 MB		8 MB		16 MB	
11.4	Number of high-speed inputs/outputs	8/8	●	8/8	●	8/8	●
11.5	Number of fieldbus inputs/outputs in bytes	8,192/8,192		8,192/8,192		8,192/8,192	
11.6	Multitasking		●		●		●
11.7	Max. number of PLC tasks	16		16		16	

12	Diagnostic and start up tools	MTX standard	MTX performance	MTX advanced
12.1	Integrated, system-crossing engineering framework IndraWorks		●	●
12.2	Status and error messages in plaintext		●	●
12.3	Integrated drive setup tools		●	●
12.4	Drive oscilloscope		●	●
12.5	Integrated PLC setup tools		●	●
12.6	Logic analyzer		●	●
12.7	Circle form test		●	●
12.8	NC analyzer		●	●
12.9	Action recorder IndraMotion MTX acr		○	○
12.10	Cycle time analyzer IndraMotion MTX cta		○	○
12.11	Energy analyzer IndraMotion MTX ega		○	○
12.12	Remote condition monitoring system IndraMotion MTX rcm		○	○
12.13	Remote diagnostics I-Remote		○	○
12.14	Software IndraMotion MTX simulator		○	○
12.15	IndraWorks view 3D		○	○
12.16	IndraWorks machine simulator		○	○
13	Open architecture	MTX standard	MTX performance	MTX advanced
13.1	Configurable standard user interface with all standard functions		●	●
13.2	Projectable, user-specific operator graphics		●	●
13.3	Adaptation and integration via standardized interfaces (OPC, XML, ActiveX, .NET)		●	●
14	Control hardware and interfaces	MTX standard	MTX performance	MTX advanced
14.1	CPU	IndraControl L45	IndraControl L65	IndraControl L85
14.2	Digital drive interface sercos	100 MBaud	● 100 MBaud	● 100 MBaud
14.3	PROFIBUS master/slave	12 MBaud	● 12 MBaud	● 12 MBaud
14.4	Ethernet TCP/IP	10/100 MBaud	● 10/100 MBaud	● 10/100 MBaud
14.5	EtherNet/IP adapter (slave)		○	○
14.6	PROFINET		○	○
15	Software and hardware	MTX standard	MTX performance	MTX advanced
15.1	Operating system Windows XP/Windows 7		○	○
15.2	Panel PC IndraControl VPP 16/40* – CPU: Intel Celeron P4500, 1.86 GHz oder Core I5, 2.4 GHz oder Core I7, 2.,66 GHz – TFT display: 30.5 cm (12“)/38.1 cm (15“) – 16 machine function keys		○	○
15.3	Industrial PC IndraControl VPB 40* – CPU: Intel Celeron P4500, 1.86 GHz oder Core I5, 2.4 GHz oder Core I7, 2.66 GHz		○	○
15.4	Embedded-PC IndraControl VEP 40/50* – CPU: Intel Atom Z510, 1.1 GHz, 1 GB RAM – TFT display: 30.5 cm (12“)/38.1 cm (15“) – 16 machine function keys		○	○

● Default

○ Optional

■ Optional in connec. with a PC

□ Optional with IndraDrive

* For details, see the product catalog “Automation systems and control components“, IndraControl V

Bosch Rexroth AG

Electric Drives and Controls

P.O. Box 13 57

97803 Lohr, Germany

Bgm.-Dr.-Nebel-Str. 2

97816 Lohr, Germany

Phone +49 9352-40-0

Fax +49 9352-40-4885

www.boschrexroth.com/electrics

Find your local contact person here:

www.boschrexroth.com/addresses