

SafeLogic compact Safety in a small format



Safety on Board – integrated, certified and seamless

Safety on Board stands for intelligent safety solutions developed by Rexroth to protect man and machine. This innovative safety solution meets the most demanding safe motion, peripheral signal processing and communication standards. Safety on Board: functional safety from Rexroth, the specialist for all control and drive technologies.

Safety on Board

Rexroth's standard-compliant products deliver functional safety across all automation levels and technologies. From the component level right up to system solutions, we provide the support machine manufacturers need to deploy cost-effective applications. Our portfolio also includes a range of professional services and hands-on training.

Integrated

Maximum protection of human health, simplified commissioning and validation and less idle time are just a few of the advantages of Safety on Board technology. Optimal interaction between the automation and safety systems reduces the risk that protective mechanisms will be manipulated, and it makes a vital contribution to accident prevention.

Certified

Safety on Board delivers maximum reliability to machine manufacturers based on safety technology which is tested and certified for compliance with the latest standards. The time and effort involved in validation is reduced to a minimum, and manufacturers enjoy the benefits of functional safety and legal certainty.

Seamless

SafeMotion and SafeLogic blend seamlessly into a holistic safety solution which extends from the drive to the control system. Rexroth delivers safe, tailored automation technology ranging from homogenous system solutions and heterogeneous automation topologies to stand-alone components.



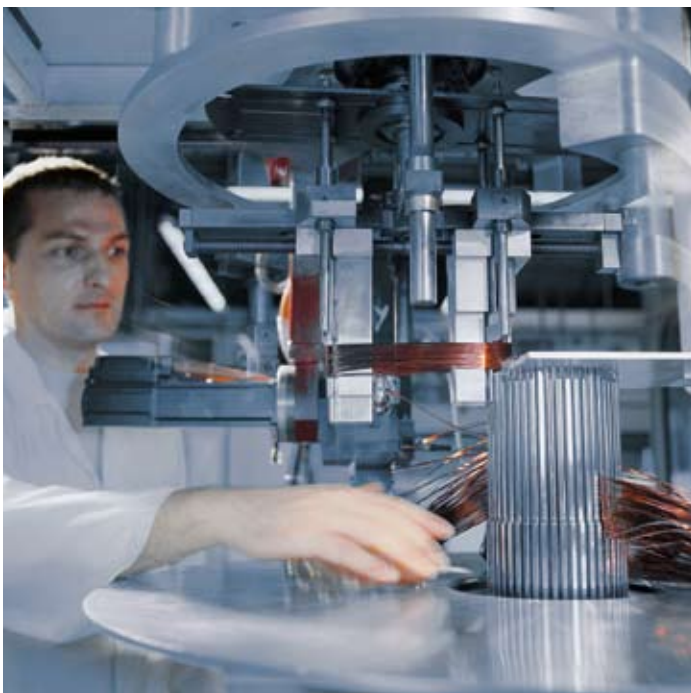

SafeLogic compact

is Rexroth's small safety control which features modular scalability, open architecture, user-friendly programming and intuitive parameterization. It is designed for deployment in safety applications on small and mid-size machines.

SafeLogic (in preparation)

The Rexroth safety control which enhances the functionality of the standard control and extends the logic processing portfolio at the high end. SafeLogic is a powerful, user-programmable safety control for machines and extensive, interlinked systems with a large number of safety peripherals.

SafeMotion

Rexroth's drive-based safety solution goes far beyond "Safe Stop" on machines and systems. SafeMotion provides the basis for safe machine design. It gives the operator access with minimized risk to the process and increases availability by reducing downtime. The result is higher productivity.

◀ **Safety on Board simplifies the implementation of machine design strategies and helps reduce non-productive time. It provides a path to standard-compliant implementation of machine-specific C standards and safety standards such as ISO 13849 and IEC 62061 while at the same time enhancing overall system effectiveness.**

SafeLogic compact – Safety in a small format

The small programmable SafeLogic safety control is the ideal solution for safe logic processing in small to mid-range machines. The control expands as the number of peripherals increases. Defined functional modules and graphic wiring simplify configuration and speed up the commissioning process.

SafeLogic compact is the ideal small controller for cost-effective deployment of safe logic processing up to ISO 13849 PL e/Cat. 4 and IEC 62061 SIL3.

Minimum reaction times protect the safety of man and machine. Users can choose the sensor and actuator technology that meets their particular needs. Fast, reliable signal processing is guaranteed on electrical, hydraulic or pneumatic subsystems.

Safe communication between up to four SafeLogic compact controls supports the implementation of simple, modular machine designs.

Flexible configuration and extensive module libraries make SafeLogic compact the obvious choice for a whole range of applications including:

- ▶ machine tools
- ▶ print and processing machines
- ▶ packaging machines
- ▶ presses
- ▶ handling and assembly systems
- ▶ general automation

You the user benefit from the impressive advantages which Safe-Logic compact has to offer:

- ▶ Fast-Shut-off function to quickly shut off the outputs
- ▶ modular system design and row mounting minimizes space utilization in the control cabinet
- ▶ extensive interface portfolio for flexible integration into the overall system automation
- ▶ EFI interface for reliable station networking and optimized sensor data analysis
- ▶ plug with application memory for hardware swap without a PC
- ▶ fast drag & drop configuration
- ▶ graphic wiring simplifies programming
- ▶ extensive module library to support analysis, diagnostics and logic processing of peripheral signals (e.g. for presses)
- ▶ user-friendly report function for quick application verification and documentation



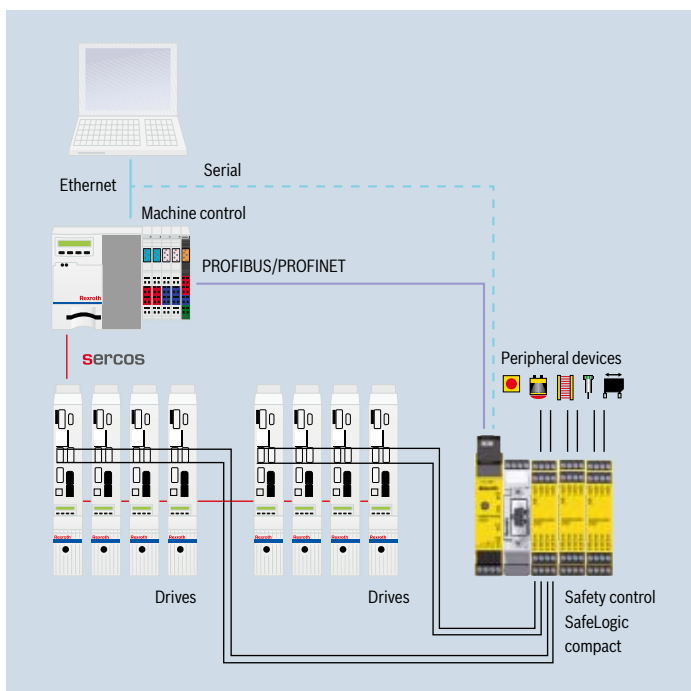
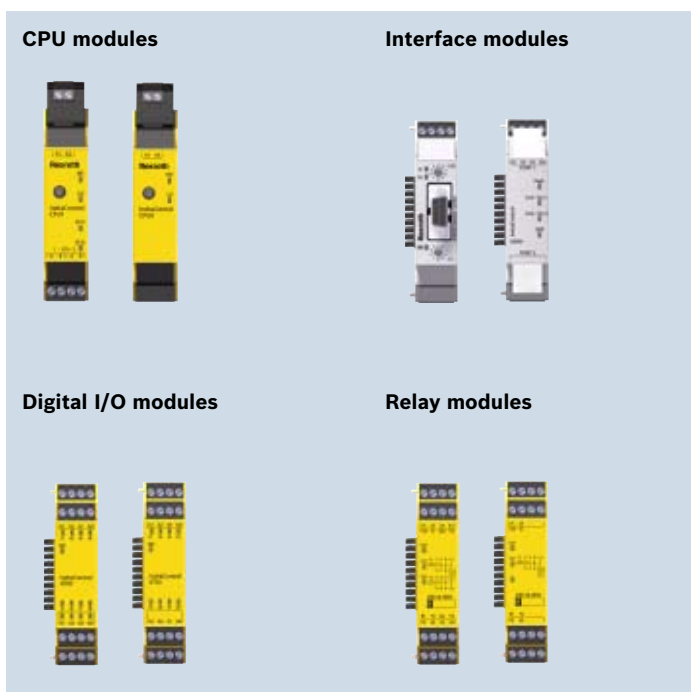

Portfolio

SafeLogic compact small safety controls feature a modular design and can be adapted to meet the exact needs of the applications. The following modules are available:

- ▶ CPU module with/without EFI interface
- ▶ interface modules for system integration
- ▶ digital I/O modules
- ▶ relay modules with check-back contacts

Control design configuration

SafeLogic compact control consists of the following:

- ▶ a CPU module
- ▶ up to two interface modules
- ▶ up to twelve digital I/O modules
- ▶ expansion relay modules

Peripheral integration

Signals from peripherals such as emergency stop buttons, laser scanners and safety switches are connected directly to the input modules on the SafeLogic compact. Contactors and hydraulic and pneumatic actuators are attached directly to the output modules. Discrete wiring can also be used to access the safety functions in Rexroth IndraDrive drive series products.

System integration

An interface module on the SafeLogic compact handles the transfer of control, diagnostic and status information as well as peripheral signals between the safety controller and the standard controller.

Engineering

For configuration, programming, commissioning and diagnostics, SafeLogic compact communicates with the engineering tools via the serial port or via the standard control using Ethernet routing.

Engineering – simple and efficient

Engineering

SafeLogic Designer is the engineering tool which is used to configure, parameterize, program, commission and run diagnostics on the SafeLogic compact. Maximum usability was a major priority during program development. The result is an intuitive user-interface with an easy-to-use but powerful logic editor. Drag & drop or component scanning is used to configure the control. Parameterization of the physical inputs and outputs is also accomplished by dragging and dropping actuators and sensors which are stored in a peripherals library. A symbolic variable can be allocated to all inputs and outputs. The tool compares the application with the control data and reports the appropriate modifications.

Module library

Programming is also performed by graphically wiring up functional blocks. Users have access to a large function block library, and user-specific functions can easily be added. A total of 255 modules can be interconnected. Program execution time is displayed to the user during the programming phase.

Simulation

Simulation mode can be used to verify programs offline. The tool simulates the control inputs and compares the reaction at the control outputs with the defined specification.

Report

This function generates a report for the entire project which is used for verification and documentation. Users can document and archive a full set of component, configuration, parameterization and programming information at the press of a button.

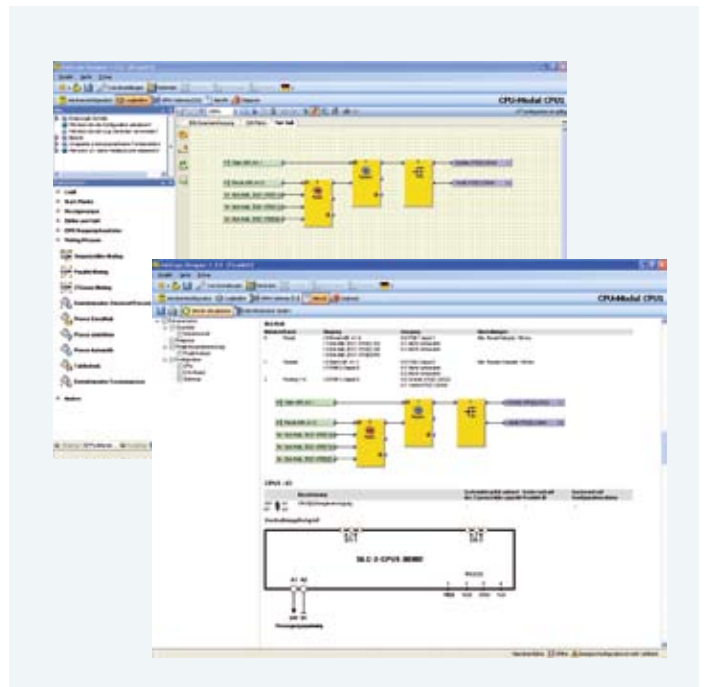

Networking – fast and secure

EFI

The Enhanced Function Interface (EFI) provides problem-free connectivity to the SafeLogic compact for sensors that have an EFI interface. EFI-enabled sensors can transfer data which goes beyond the OSSD signals (Output Signal Switching Device), for example to switch the scanning field of a laser scanner.

EFI-Link

Alternatively, EFI can be used for secure networking of up to four safety controls. Up to 52 bit safety data can be exchanged across cells over the network.

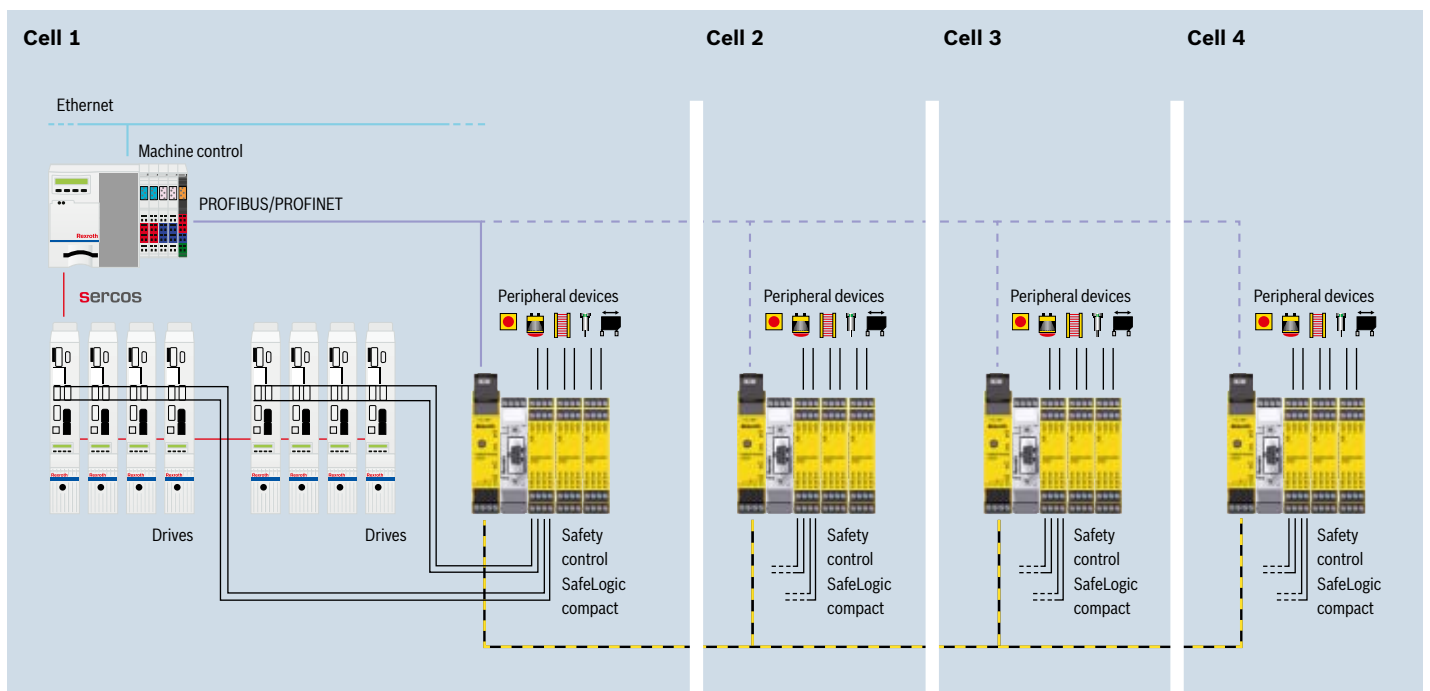
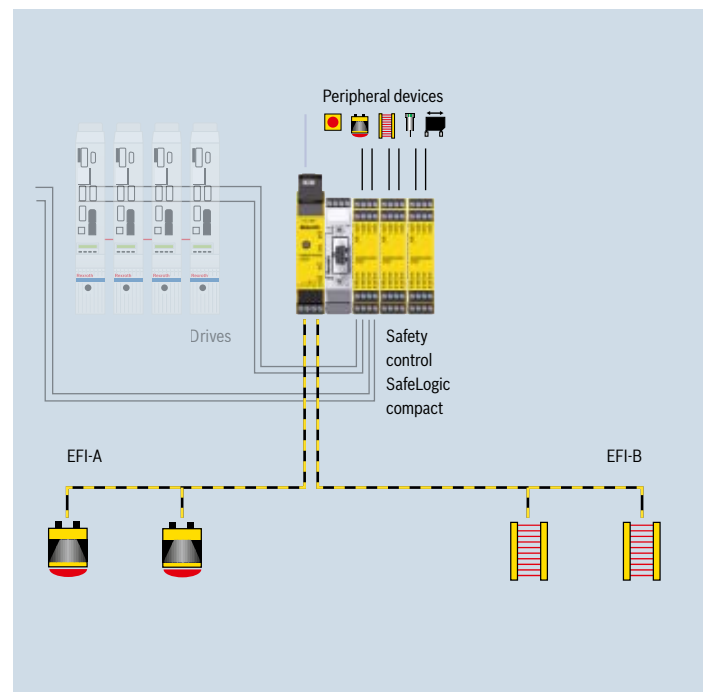

Bosch Rexroth AG

P.O. Box 13 57
97803 Lohr, Germany
Bgm.-Dr.-Nebel-Str. 2
97816 Lohr, Germany
Phone +49 9352-40-0
Fax +49 9352-40-4885
www.boschrexroth.com

Find your local contact person here:

www.boschrexroth.com/addresses

The data specified above only serve to describe the product.

As our products are constantly being further developed, no statements concerning a certain condition or suitability for a certain application can be derived from our information. The information given does not release the user from the obligation of own judgment and verification. It must be remembered that our products are subject to a natural process of wear and aging.