

Quick & Easy profile finishing

Logical structure of the order key

Material number / length / [slot designation = finishing; parameter set]

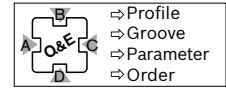

Example: Profile 45x90L with through-hole D17 in slot B

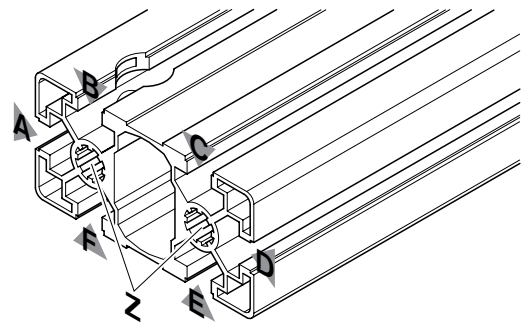

3 842 993 662 / 393 / B = D17/-

Material number	Length	Standard profile finishing D17 through-hole in slot B
-----------------	--------	--

Standard profile finishing

- ▶ Through-hole drilling D
- ▶ Blind hole drilling DB
- ▶ Thread cutting M
- ▶ Standard milling F1

Individual profile finishing

- ▶ Hole drilling DI
- ▶ Drilling sequence DIS
- ▶ Cross milling MT
- ▶ Cross milling sequence MTS
- ▶ Lengthwise milling MI
- ▶ Lengthwise milling sequence MIS
- ▶ Miter cut S1 / S3



You can configure your profile really quickly and easily in the Rexroth eShop or with the profile configurator in MTpro

