

Directional servo valve, with integrated electronics (OBE)

Type 4WSE3E



- ▶ Size 25
- ▶ Component series 3X
- ▶ Maximum operating pressure 350 bar
- ▶ Maximum flow 1020 l/min
- ▶ Nominal flow 210 ... 450 l/min ($\Delta p = 70$ bar)

Features

- ▶ 4-way version
- ▶ Valve for position, force, pressure or velocity control
- ▶ Subplate mounting
- ▶ Porting pattern according to ISO 4401-08-08-0-05
- ▶ 3-stage servo valve with electrical position control of the 3rd stage control spool and position sensing via inductive position transducer
- ▶ 2-stage pilot control valve (size 6) with high dynamics
- ▶ Filter for 1st stage freely accessible and replaceable from the outside
- ▶ Optimized valve control loop
- ▶ High response sensitivity, very low hysteresis and zero point drift
- ▶ Internal or external pilot oil supply and return

Contents

Features	1
Ordering code	2, 3
Symbols	3
Function, section	4
Technical data	5 ... 7
Block diagram/controller function block	8 ... 10
Electrical connections and assignment	11
Characteristic curves	12 ... 15
Dimensions	16, 18
Flushing plate	17
Accessories	18
Project planning information	19
Further information	19

Ordering code

01	02	03	04	05	06	07	08	09	10	11	12	13	14	15	16	17
4	WSE3E	25					3X	/		9	/	24	K31	/		*

01	4 main ports	4
02	Directional servo valve, 3-stage, with integrated electronics (OBE)	WSE3E
03	Size 25	25
04	Symbols; possible version see page 3	

Control spool position in de-energized state

05	Not defined	no code	◇
	100 % P→A, B→T	P	
	100 % P→B, A→T	N	

Nominal flow ($\Delta p = 70$ bar)

06	210 l/min	200	
	300 l/min	300	
	380 l/min	400	
	450 l/min	500	◇

Control spool overlap (in % of the nominal stroke)

07	0 ... 0.5 % negative	E	◇
	0 ... 0.5 % positive	D	
08	Component series 30 ... 39 (30 ... 39: unchanged installation and connection dimensions)	3X	

Seal material (observe compatibility of seals with hydraulic fluid used, see page 6)

09	NBR seals	M	
	FKM seals	V	

Pilot oil flow

10	External pilot oil supply, external pilot oil return	XY	
	External pilot oil supply, internal pilot oil return	XT	
	Internal pilot oil supply, external pilot oil return	PY	
	Internal pilot oil supply, internal pilot oil return	PT	◇

Pressure rating

11	315 bar	9
12	Supply voltage 24 V	24

Electrical connection

13	Connector, 7-pole (6 + PE) according to EN 175201-804	K31 ¹⁾
----	---	--------------------------

Electrical interface

14	Command value input ± 10 V; actual value output ± 10 V	A1	◇
	Command value input 4 ... 20 mA; actual value output 4 ... 20 mA	F1	
	Command value input ± 10 mA, actual value output 4 ... 20 mA (only version "-140")	C6	

Test certificates

15	None	no code	◇
	With acceptance test certificate 3.1 according to EN 10204 ²⁾	3	

Ordering code

01	02	03	04	05	06	07	08	09	10	11	12	13	14	15	16	17
4	WSE3E	25					3X	/		9	/	24	K31	/		*

Special versions

16	Without	no code
	Enable input on pin C (always for version "C6")	-140 ³⁾
17	Further details in the plain text	

- Mating connectors, separate order, see page 18 and data sheet 08006.
- When ordering, the functional certificate material number must be specified in addition to the valve material number:
 - Functional certificate 3.1: **R900259791**
- Without enable signal, valve regulated in central position.
Central position adjustable via potentiometer in the range $\pm 10\%$.

 **Notice:** \diamond = Preferred type

Symbols

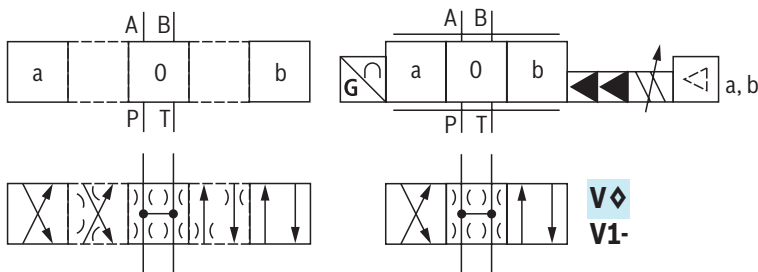



With symbol V:

P→A: $q_{V \max}$ B→T: $q_{V \max}$
 P→B: $q_{V \max}$ A→T: $q_{V \max}$

With symbol V1-:

P→A: $q_{V \max}$ B→T: $q_{V/2}$
 P→B: $q_{V/2}$ A→T: $q_{V \max}$

 **Notes:**
 Representation according to ISO 1219-1.
 Hydraulic interim positions are shown by dashes.

 **Notice:** \diamond = Preferred type

Function, section

Valves of type 4WSE3E are electrically operated, 3-stage directional servo valves. They are mainly used to control position, force or pressure and velocity.

Set-up

The valves consist of the following assemblies:

- ▶ 2-stage pilot control valve type 4WS2EM 6 (1)
- ▶ Main stage with a main control spool in a sleeve (2)
- ▶ Inductive position transducer (3)
- ▶ Integrated electronics (OBE) (4).

The pilot control valve (1) consists of

- ▶ Electro-mechanical converter (torque motor)
- ▶ Hydraulic amplifier (nozzle flapper plate principle)
- ▶ Pilot control spool in a sleeve, connected to the torque motor via a mechanical feedback.

Function

Electric currents in the coils of the torque motor generate a force by means of a permanent magnet which acts on the armature, and in connection with a torque tube results in a torque. This causes the flapper plate which is connected to the torque tube via a bolt to move from the central position between the two control nozzles, and a pressure differential is created across the front sides of the pilot control spool. The pressure differential results in the control spool changing its position, which results in the pressure port being connected to one actuator port and, at the same time, the other actuator port being connected to the return flow port. The pilot control spool is connected to the flapper plate or the torque motor by means of a bending spring (mechanical feedback).

The position of the control spool is changed until the flapper plate position and hence the pressure differential across the nozzle flapper plate system becomes zero due to the feedback torque, which acts via the bending spring against the electro-magnetic torque of the torque motor. In doing so, the stroke of the pilot control spool, and hence the flow of the pilot control valve, is regulated proportionally to the electrical input signal.

In the main stage, the main control spool (2) is operated by the pilot control valve and its position is sensed by an inductive position transducer (3). The position transducer signal is compared with the command value by the integrated electronics (4). Any possible control deviation is amplified electrically and fed to the pilot control valve as control signal. The pilot control valve starts to move and the main control spool is re-positioned.

The stroke of the main control spool and consequently the flow of the servo valve are regulated proportionally to the command value. It must be noted that the flow depends on the pressure differential.

The valves are set at the factory with a dither default setting with the constant frequency of 400 Hz.

Adjustable via externally accessible potentiometers:

- ▶ "A1": Valve zero point (6)
- ▶ "F1": Valve zero point (6)
- ▶ "C6":
 - Valve zero point, with enable (7)
 - Adjustable central position, without enable (8)

5 Plug screw PG7

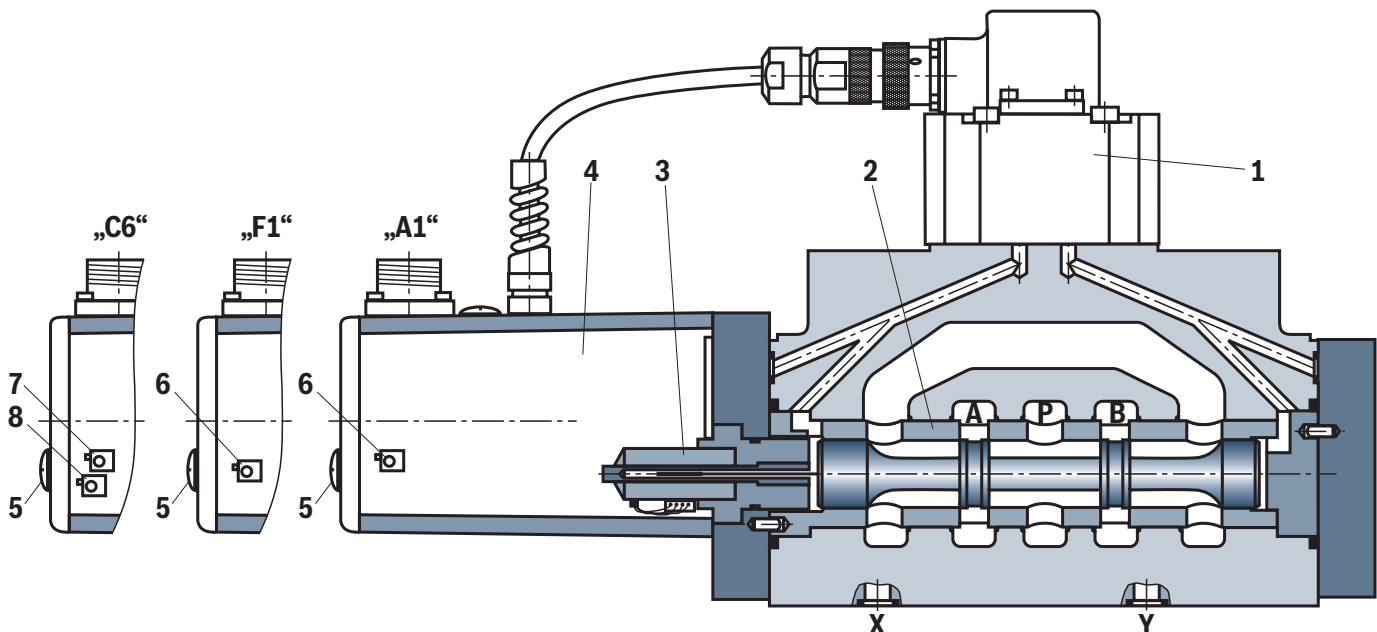

Technical data

(For applications outside these values, please consult us!)

General	
Type of connection	Subplate mounting
Porting pattern	ISO 4401-08-08-0-05
Weight	kg 16
Installation position	Any, if it is ensured that the pilot control is supplied with sufficient pressure (> 10 bar) during start-up of the system. In case of insufficient pressure supply, the control spool of the servo valve can be in any position. This may result in channel P being connected to the actuator and the pressure build-up being delayed. This may be prevented by providing an external pressure supply at port X.
Ambient temperature range	°C -20 ... +60
Storage temperature range (with UV protection)	°C -5 ... +40
Maximum storage time	Years 1 (if the storage conditions are observed, refer to the operating instructions 07600-B)
Protection class according to EN 60529	IP65 (if suitable and correctly mounted mating connectors are used)
Sine test according to EN 60068-2-6	10 ... 2000 Hz / maximum 10 g / 10 cycles / 3 axes
Noise test according to EN 60068-2-64	20 ... 2000 Hz / 10 g _{RMS} / 30 g peak / 30 min / 3 axes
Transport shock according to EN 60068-2-27	15 g / 11 ms / 3 axes
Conformity	► RoHS Directive 2011/65/EU ¹⁾

Hydraulic		
Maximum operating pressure	► Pilot control valve	
	– Pilot oil supply X	bar 10 ... 315
	– Port Y	Pressure peaks <100 admissible, static <10
	► Main valve, port P, A, B	
	– Internal pilot oil supply	bar 315
	– External pilot oil supply	bar 350
Hydraulic fluid	► Main valve, port T	
	– Internal pilot oil supply	bar Pressure peaks <100 admissible, static <10
	– External pilot oil supply	bar 250
Hydraulic fluid		See table, page 6
Hydraulic fluid temperature range	°C	-20 ... +80
Viscosity range	► Maximum	15 ... 380
	► Recommended	30 ... 45
Maximum admissible degree of contamination of the hydraulic fluid; cleanliness class according to ISO 4406 (c)	► Pilot control valve	Class 18/16/13 ²⁾
	► Main valve	Class 20/18/15 ²⁾
Nominal flow ($\Delta p = 70$ bar; tolerance ± 10 %)		210, 300, 380, 450
Maximum pilot flow (with stepped input signal, 0 → 100 %, pilot pressure 315 bar)	l/min	14

1) The product fulfills the substance requirements of the RoHS Directive 2011/65/EU.

2) The cleanliness classes specified for the components must be adhered to in hydraulic systems. Effective filtration prevents faults and at the same time increases the life cycle of the components.

Technical data

(For applications outside these values, please consult us!)

Hydraulic fluid	Classification	Suitable sealing materials	Standards	Data sheet
Mineral oils	HL, HLP, HLPD, HVLP, HVLPD	NBR, FKM	DIN 51524	90220
Bio-degradable	▶ Insoluble in water	HETG	ISO 15380	90221
		HEES		
	▶ Soluble in water	HEPG	ISO 15380	
Flame-resistant	▶ Water-free	HFDU (glycol base)	ISO 12922	90222
		HFDU (ester base)		
		HFDR		
	▶ Containing water	HFC (Fuchs: Hydrotherm 46M, Renosafe 500; Petrofer: Ultra Safe 620; Houghton: Safe 620; Union: Carbide HP5046)	NBR	ISO 12922



Important information on hydraulic fluids:

- ▶ For further information and data on the use of other hydraulic fluids, please refer to the data sheets above or contact us.
- ▶ There may be limitations regarding the technical valve data (temperature, pressure range, life cycle, maintenance intervals, etc.).
- ▶ The ignition temperature of the hydraulic fluid used must be 50 K higher than the maximum surface temperature.
- ▶ **Bio-degradable and flame-resistant – containing water:**
If components with galvanic zinc coating (e.g. version "J3" or "J5") or parts containing zinc are used, small amounts of dissolved zinc may get into the hydraulic system and cause accelerated aging of the hydraulic fluid. Zinc soap may form as a chemical reaction product, which may clog filters, nozzles and solenoid valves – particularly in connection with local heat input.

▶ Flame-resistant – containing water:

- Due to an increased cavitation tendency with the use of HFC hydraulic fluids, the life cycle of the component may be reduced by up to 30 % as compared to use with HLP mineral oil. In order to reduce the cavitation effect, it is recommended – if possible, specific to the installation – to back up the return flow pressure in ports T to approx. 20% of the pressure differential at the component.
- Dependent on the hydraulic fluid used, the maximum ambient and hydraulic fluid temperature must not exceed 50 °C. In order to reduce the heat input into the component, the command value profile is to be adjusted for proportional and high-response valves.

Static / dynamic

Hysteresis	%	≤0.1
Range of inversion	%	≤0.05
Response sensitivity	%	≤0.05
Temperature drift when changing	▶ Hydraulic fluid temperature	%/10 K ≤0.3
	▶ Ambient temperature	%/10 K ≤0.3
	▶ Operating pressure	%/100 bar ≤0.3
	▶ Return flow pressure 0 ... 10 % of p_P ³⁾	%/100 bar ≤0.3
Zero point calibration	%	±1 (factory set)

³⁾ p_P = operating pressure in bar

Technical data

(For applications outside these values, please consult us!)

Electrical, integrated electronics (OBE) – interface "A1"			
Supply voltage	▶ Nominal value	VDC	24 ⁴⁾
	▶ Minimum	VDC	18
	▶ Maximum	VDC	35
	▶ Current consumption during operation ⁵⁾	mA	<230
Functional ground and screening			See pin assignment, page 11
Command value (differential amplifier)	▶ Measurement range	V	±10
	▶ Input resistance	kΩ	>100
Actual value (test signal)	▶ Output range	V	±10
	▶ Minimum load impedance	kΩ	>1

Electrical, integrated electronics (OBE) – interface "F1"			
Supply voltage	▶ Nominal value	VDC	24 ⁴⁾
	▶ Minimum	VDC	18
	▶ Maximum	VDC	35
	▶ Current consumption during operation ⁵⁾	mA	<230
Functional ground and screening			See pin assignment, page 11
Command value	▶ Input current range	mA	4 ... 20
	▶ Input resistance	Ω	100
Actual value (test signal)	▶ Output range	mA	4 ... 20
	▶ Maximum load	Ω	500

Electrical, integrated electronics (OBE) – interface "C6"			
Supply voltage	▶ Nominal value	VDC	24 ⁴⁾
	▶ Minimum	VDC	18
	▶ Maximum	VDC	35
	▶ Current consumption during operation ⁵⁾	mA	<230
Functional ground and screening			See pin assignment, page 11
Command value	▶ Input current range	mA	±10
	▶ Input resistance	Ω	200
Actual value (test signal)	▶ Output range	mA	4 ... 20
	▶ Maximum load	Ω	500
Enable	▶ Low level range	V	0 ... 6.5
	▶ High level range	V	8.5 ... 35

⁴⁾ Full bridge rectification with smoothing capacitor 2200 μF,
 $I_{\max} = 230 \text{ mA}$

⁵⁾ The making current peak is usually higher (depending on power supply unit, supply line, and capacities).

Block diagram/controller function block: Version "A1"

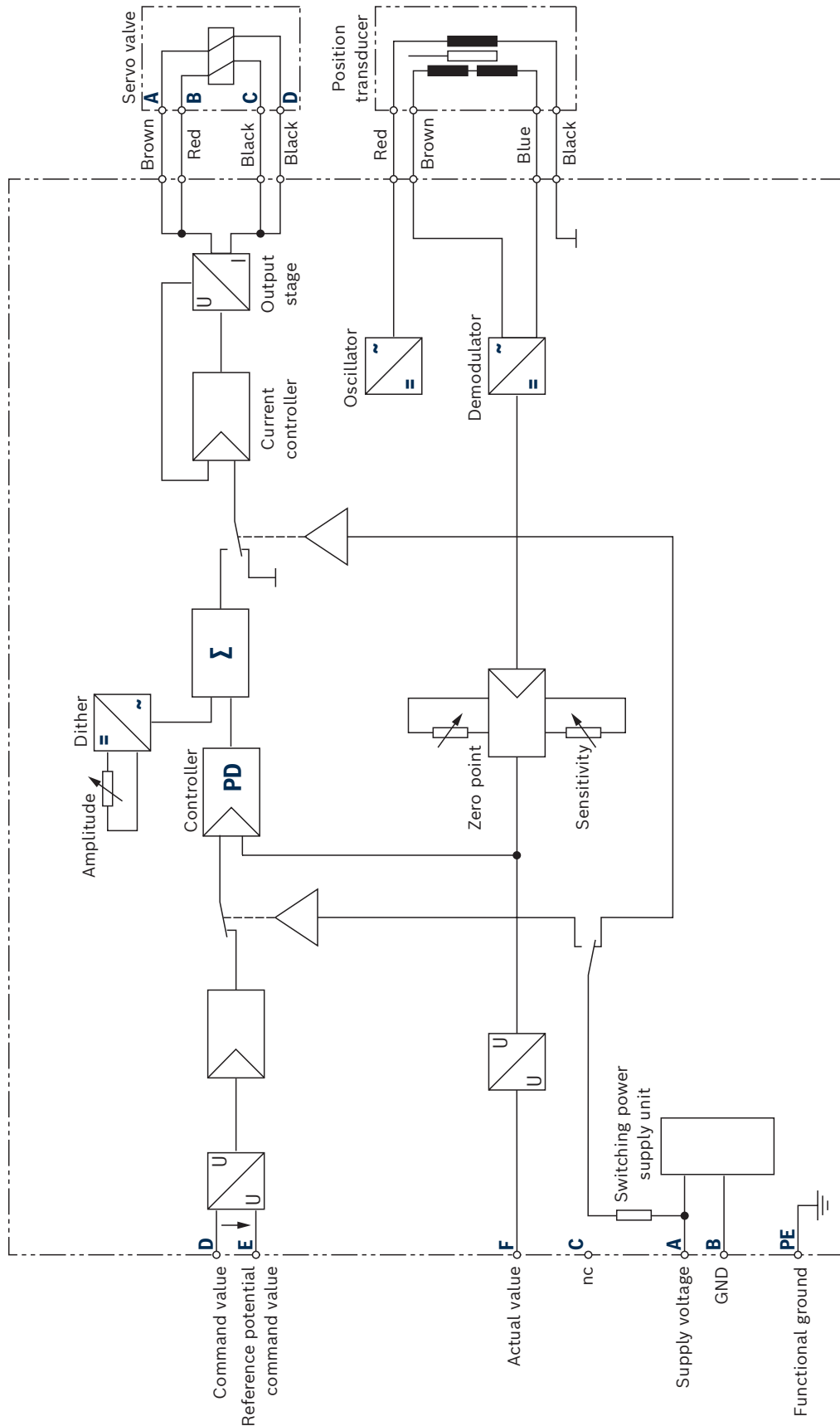

Block diagram/controller function block: Version "F1"

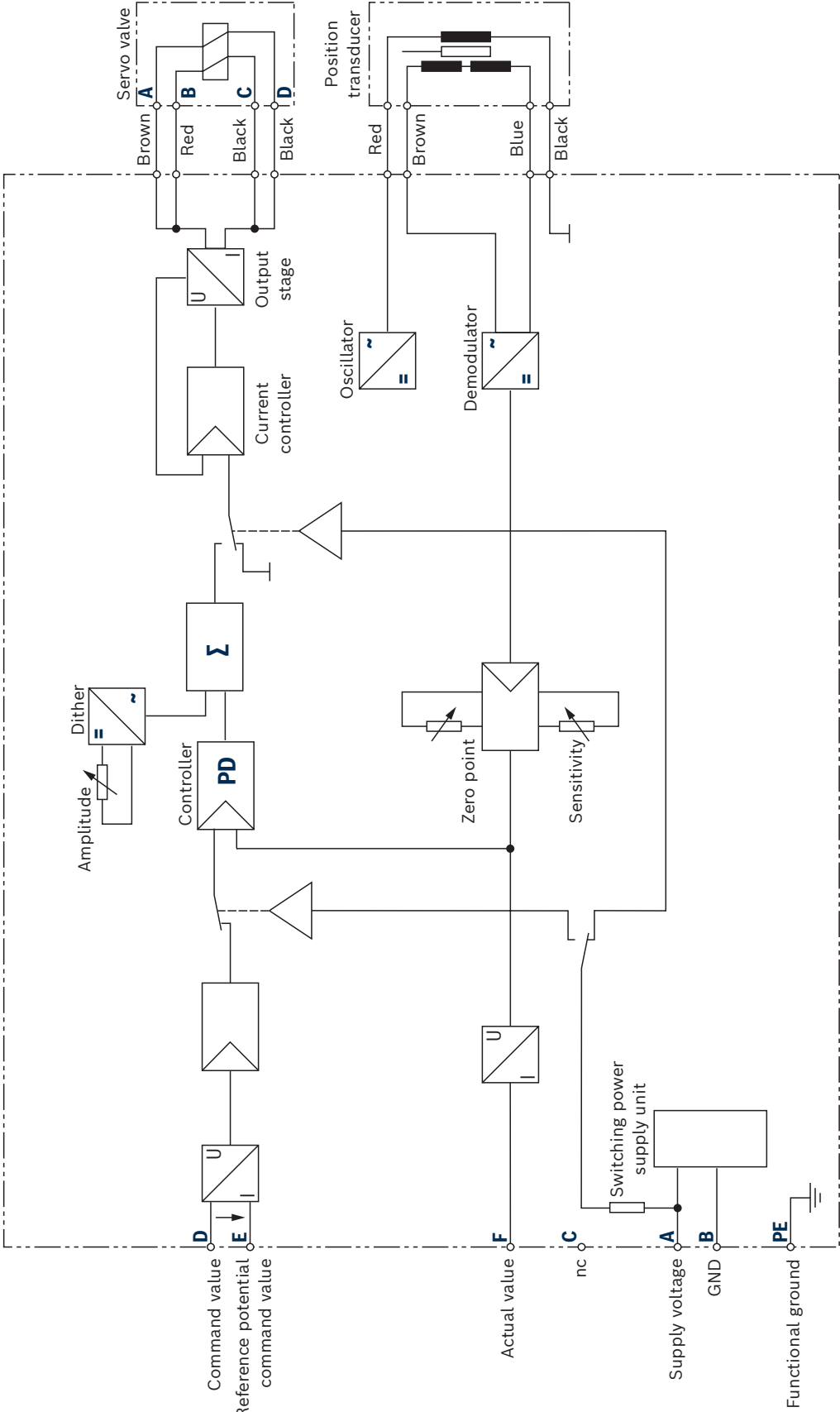

Block diagram/controller function block: Version "C6"

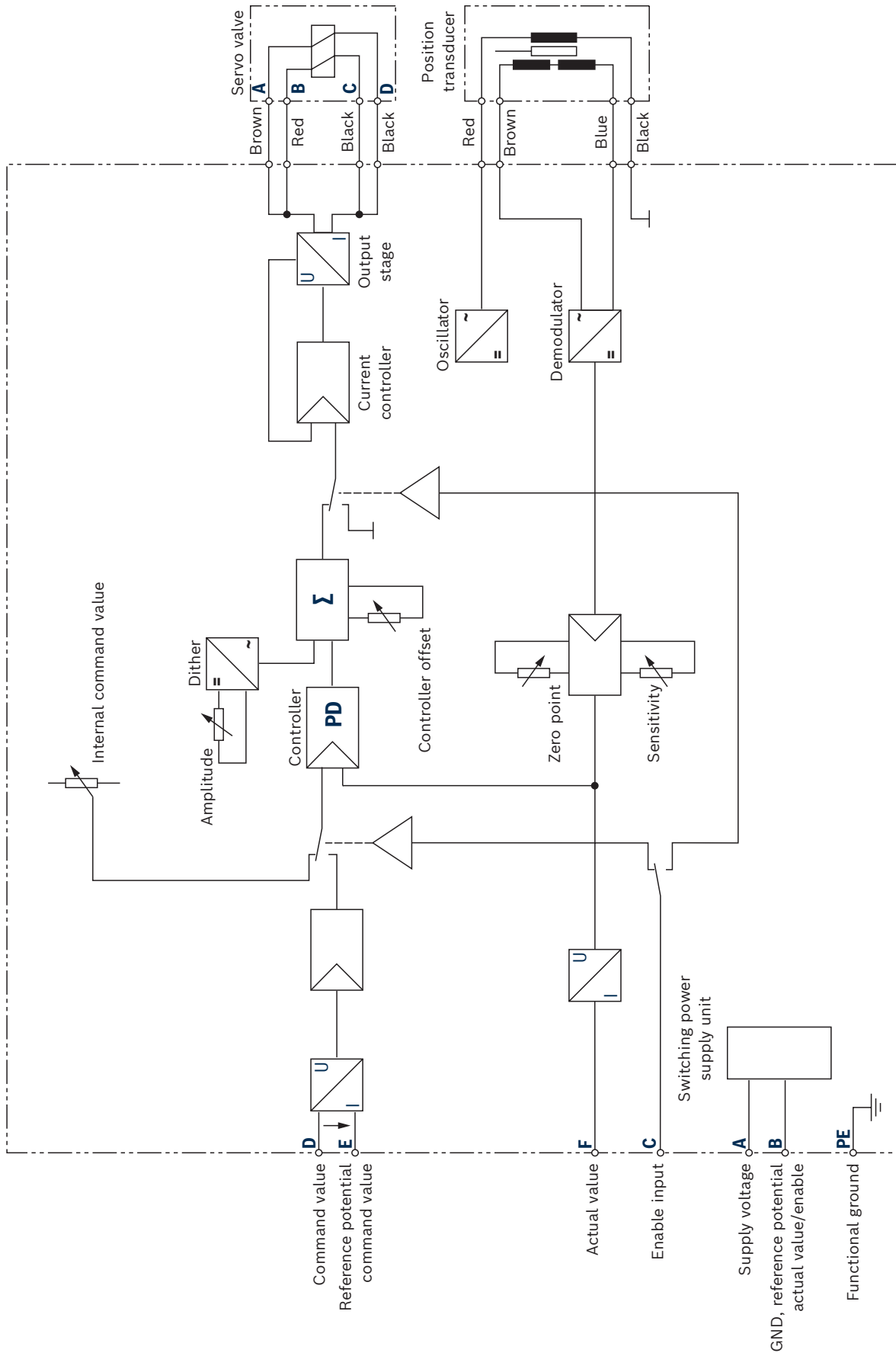

Electrical connections and assignment

Connector pin assignment "XH1", 6-pole + PE according to DIN 43563

Pin	Interface assignment		
	"A1"	"F1"	"C6"
A	Supply voltage	Supply voltage	Supply voltage
B	GND, reference potential actual value	GND, reference potential actual value	GND, reference potential actual value/enable
C	Not assigned	Not assigned	Enable input
D	Command value	Command value	Command value
E	Reference potential command value	Reference potential command value	Reference potential command value
F	Actual value	Actual value	Actual value
PE	Functional ground (directly connected to the valve housing)		

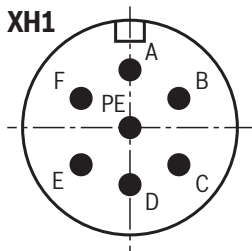

	Command value			Actual value		Switching positions 3 ("a"; "b")
	"A1"	"F1"	"C6"	"A1"	"F1"	
Positive	"A1"	0 ... +10 V	0 ... +10 V	0 ... +10 V	0 ... +10 V	P→A; B→T
	"F1"	12 ... 20 mA	12 ... 20 mA	12 ... 20 mA	12 ... 20 mA	
	"C6"	0 ... +10 mA	12 ... 20 mA	12 ... 20 mA	12 ... 20 mA	
Negative	"A1"	0 ... -10 V	0 ... -10 V	0 ... -10 V	0 ... -10 V	P→B; A→T
	"F1"	12 ... 4 mA	12 ... 4 mA	12 ... 4 mA	12 ... 4 mA	
	"C6"	0 ... -10 mA	12 ... 4 mA	12 ... 4 mA	12 ... 4 mA	

Connection cable:

- ▶ Up to 25 m cable length type LiYCY 7 x 0.75 mm²
- ▶ Up to 50 m cable length type LiYCY 7 x 1.0 mm²
- ▶ EMC-compliant installation:
 - Apply screening to both line ends
 - Use metal mating connector (see page 18)
- ▶ Alternatively up to 30 m cable length admissible
 - Apply screening on supply side
 - Plastic mating connector (see page 18) can be used

Notice:

Mating connectors, separate order, see page 18 and data sheet 08006.

Characteristic curves

(measured with HLP46, $\vartheta_{oil} = 40 \pm 5 \text{ }^\circ\text{C}$)

Flow/load function (at maximum valve opening; tolerance $\pm 10 \%$)

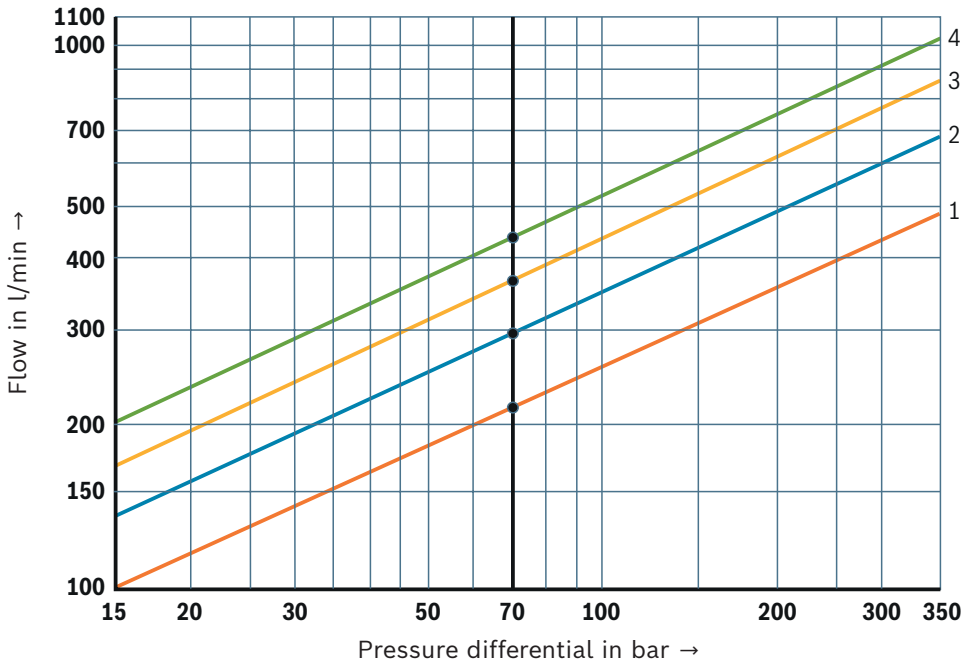

Nominal flow

- 1 210 l/min
- 2 300 l/min
- 3 380 l/min
- 4 450 l/min

$$\Delta p = p_P - p_L - p_T$$

Δp Pressure differential
 p_P Inlet pressure
 p_L Load pressure
 p_T Return flow pressure

Tolerance field of the flow/signal function (at constant pressure differential)

Summated edge ($\Delta p = 70 \text{ bar}$)

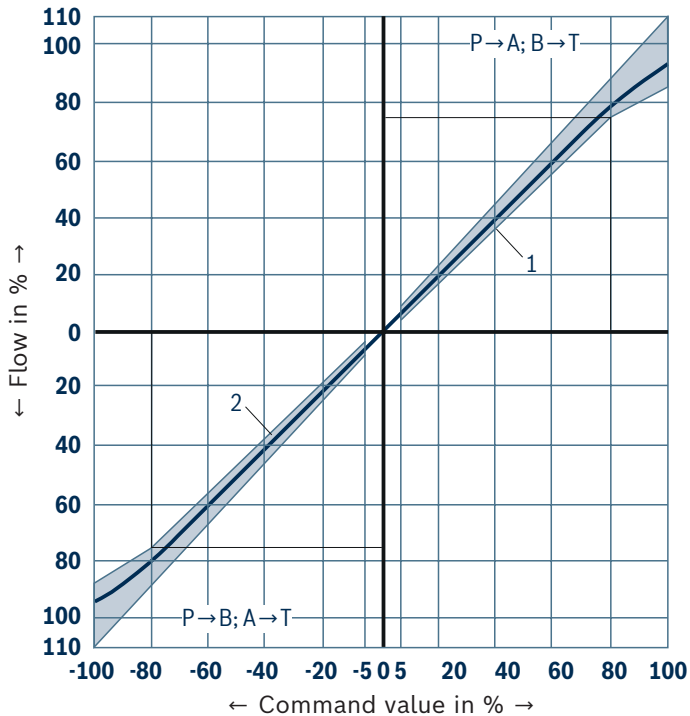

Single edge ($\Delta p = 35 \text{ bar}$; tolerance $\pm 5 \%$)

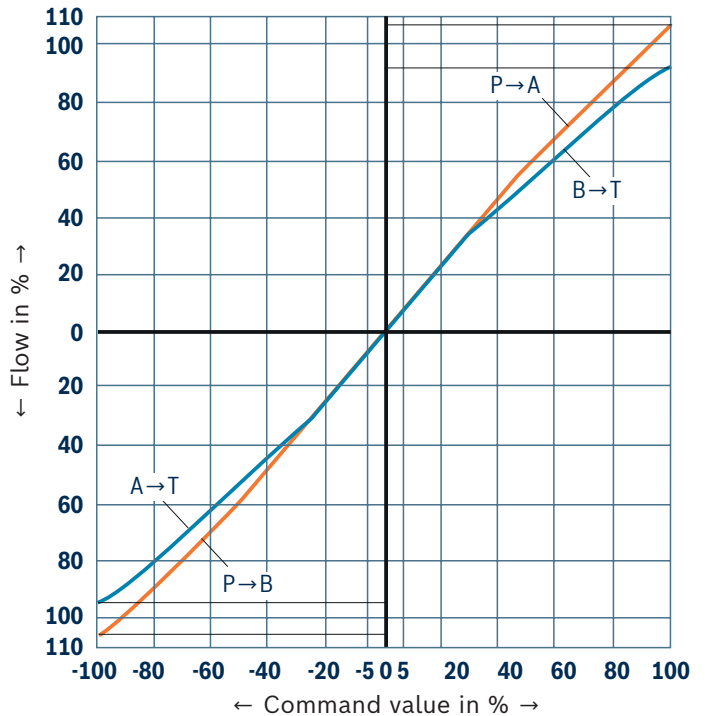

- 1 Tolerance field
- 2 Typical flow curve



Notice:

Typical characteristic curves which are subject to tolerance variations.

Characteristic curves

(measured with HLP32, $\vartheta_{oil} = 40 \pm 5 \text{ }^\circ\text{C}$)

Pressure-signal characteristic curve (measured at 280 bar)

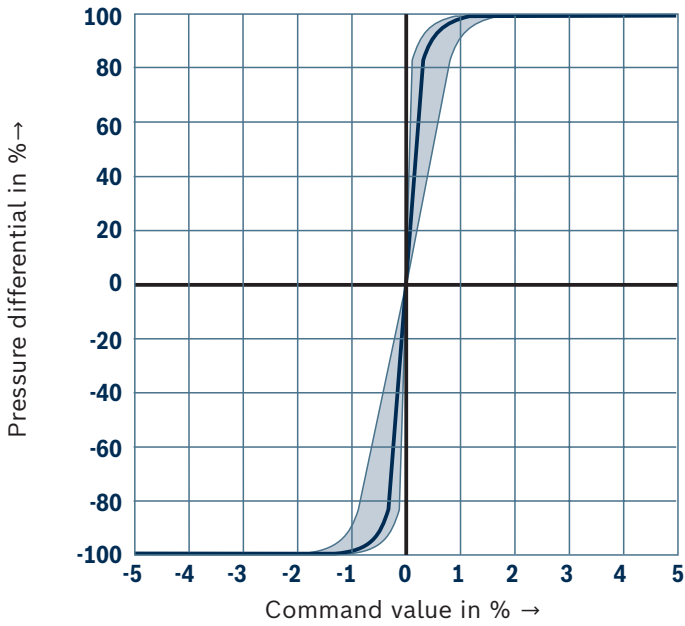

Zero flow

Version "E"

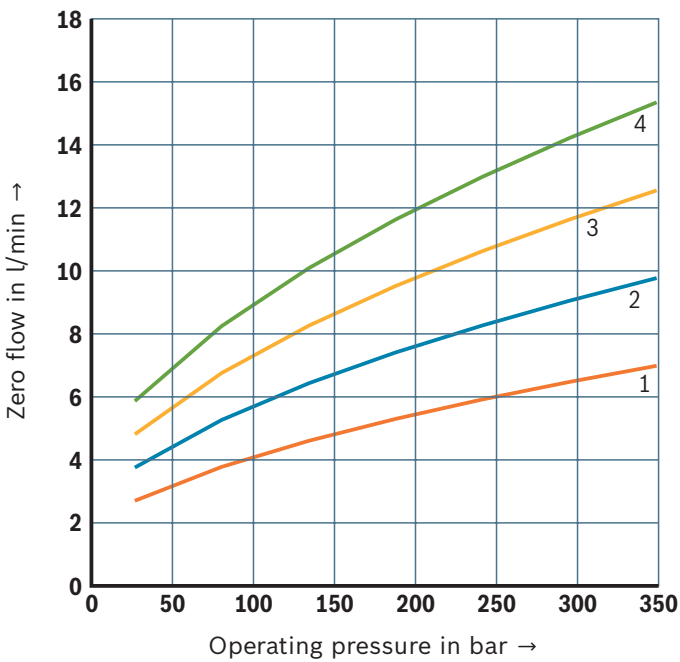

Zero flow

Version "D"

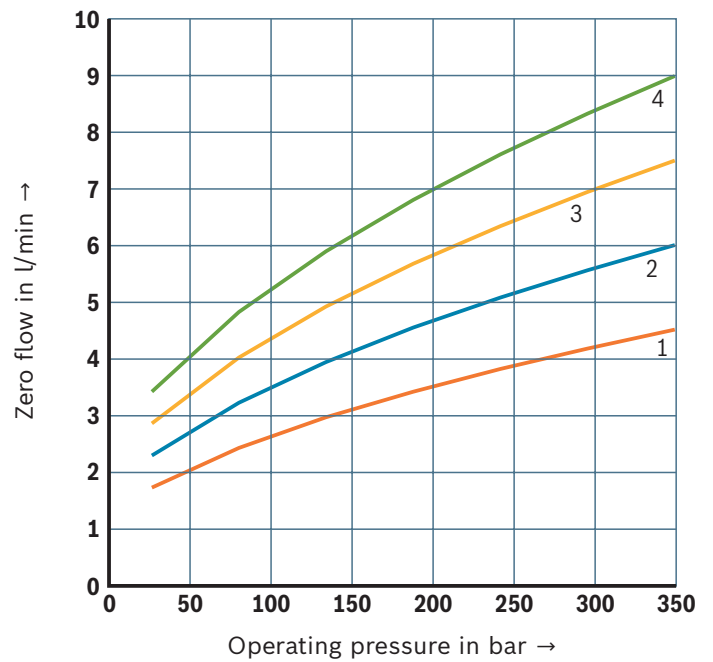

Nominal flow

- 1 210 l/min
- 2 300 l/min
- 3 380 l/min
- 4 450 l/min



Notice:

Typical characteristic curves which are subject to tolerance variations.

Characteristic curves

(measured with HLP32, $\vartheta_{oil} = 40 \pm 5 \text{ } ^\circ\text{C}$)

Transition function with stepped electric input signals (pilot pressure 315 bar)

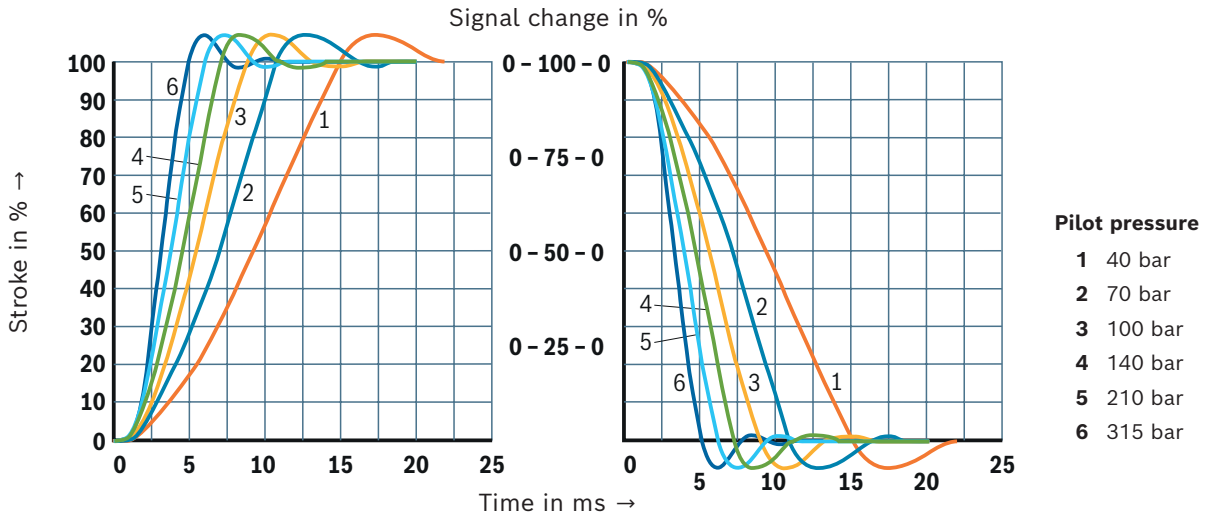

Frequency response (pilot pressure 315 bar)

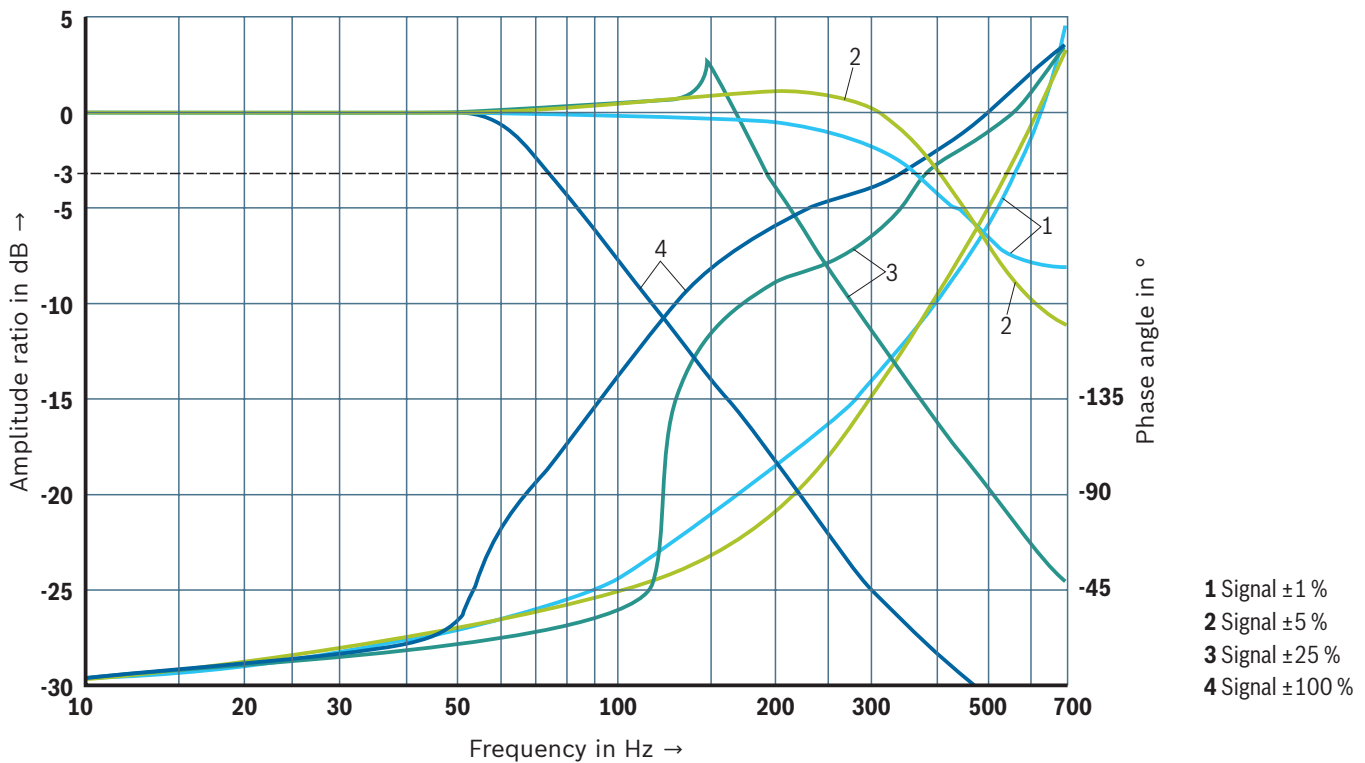

Notice:

Typical characteristic curves which are subject to tolerance variations.

Characteristic curves

(measured with HLP32, $\vartheta_{oil} = 40 \pm 5 \text{ } ^\circ\text{C}$)

Dependence -90° frequency of the pilot pressure (315 bar)

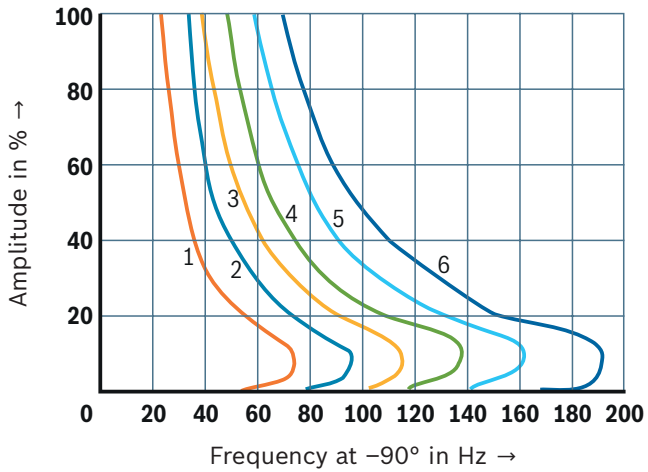

Pilot pressure

- 1 40 bar
- 2 70 bar
- 3 100 bar
- 4 140 bar
- 5 210 bar
- 6 315 bar



Notice:

Output signal corresponds to control spool stroke without flow.



Notice:

Typical characteristic curves which are subject to tolerance variations.

Dimensions
(dimensions in mm)

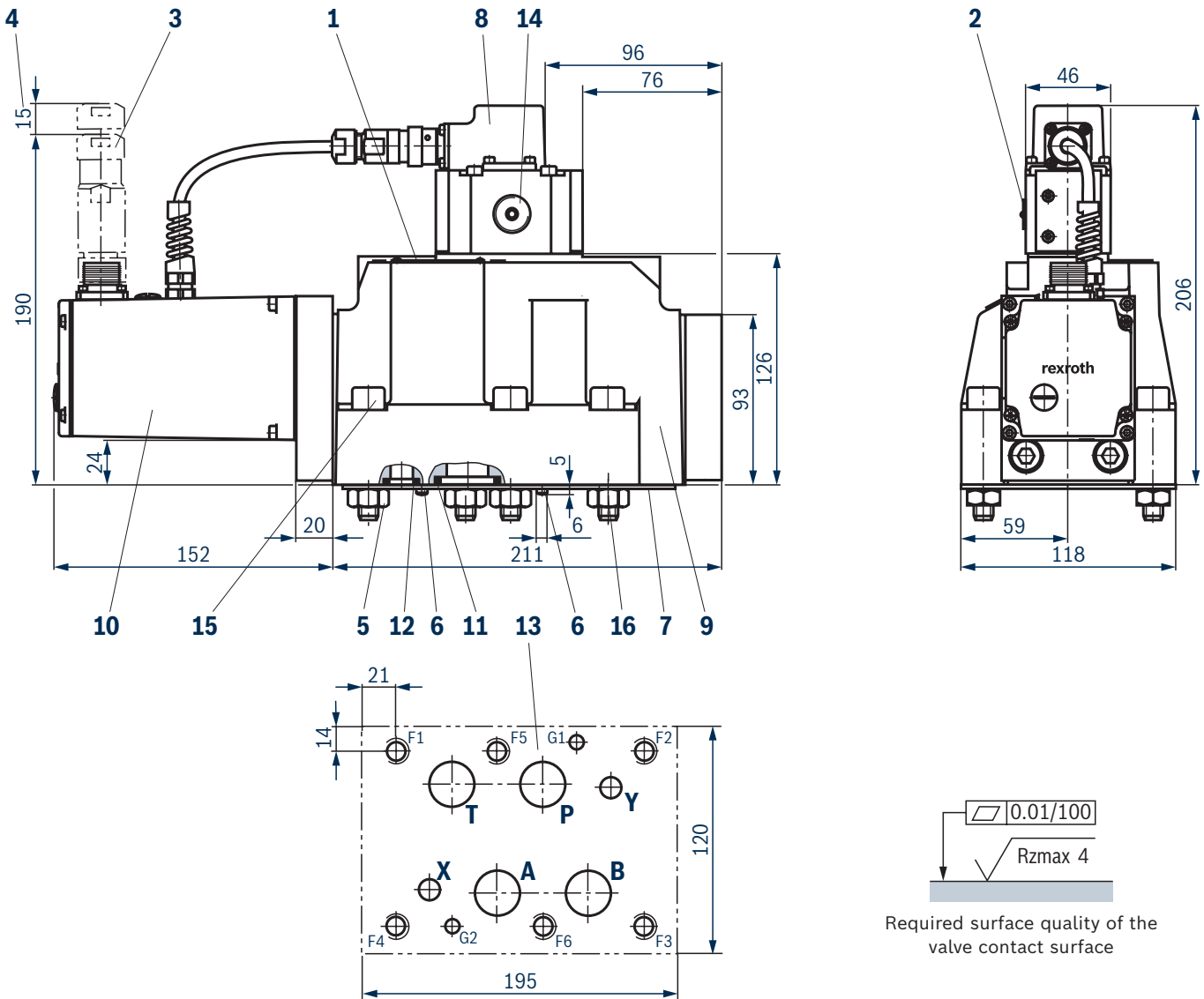

- 1 Name plate – complete valve
- 2 Name plate – pilot control valve
- 3 Mating connector, separate order, see page 18
- 4 Space required to remove the mating connector (take connection cable into account)
- 5 Hexagon nuts (for transport only)
- 6 Locating pin (2x) G1 and G2
- 7 Cover plate (for transport only)
- 8 Pilot control valve (2-stage)
- 9 Main stage (3rd stage)
- 10 Integrated electronics (OBE)
- 11 Identical seal rings for ports A, B, P, and T
- 12 Identical seal rings for ports X and Y (ports X and Y are also pressurized in case of "internal" pilot oil supply and return)
- 13 Machined valve contact surface; porting pattern according to ISO 4401-08-08-0-05

- 14 Exchangeable filter element with seals, Material no. **R961000194**
- 15 Valve mounting screws

Valve mounting screws see page 18.

Notice:
The dimensions are nominal dimensions which are subject to tolerances.

Flushing plate

(dimensions in mm)

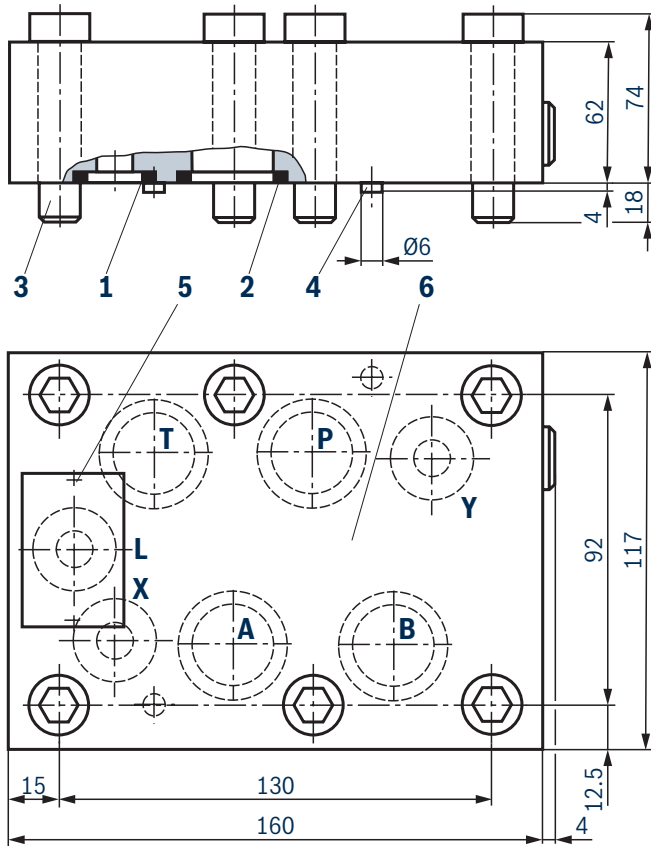

- 1 Identical seal rings for ports L, X and Y (included in scope of delivery)
- 2 Identical seal rings for ports P, T, A and B (included in scope of delivery)
- 3 **6 hexagon socket head cap screws** (included in scope of delivery)
ISO 4762 - M12 x 80 - 10.9
 Friction coefficient $\mu_{\text{total}} = 0.09 \dots 0.14$,
 Tightening torque $M_A = 100 \text{ Nm} \pm 20 \%$
 Material no. **R913014527**
- 4 2 locating pins ISO 8741 - 6x12-ST
- 5 Name plate
- 6 Porting pattern according to ISO 4401-08-08-0-05



Notice:

To ensure proper operation of the servo valves, it is necessary to flush the system before commissioning. The following values are guidelines for the flushing time per system:

$$t \geq \frac{V}{q_v} \cdot 5$$

t = Flushing time in hours

V = Tank capacity in liters

q_v = Pump flow in liters per minute

When replenishing more than 10 % of the tank capacity, the flushing procedure must be repeated.

A more suitable option than a flushing plate is the use of a directional valve with connection according to ISO 4401-08-08-0-05. With this valve, you can also flush the actuator ports (see data sheet 07700).

Symbols

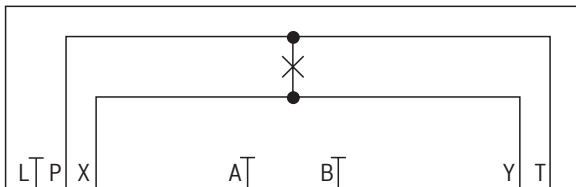

FKM seals

Material no. **R900959384**

Weight: 8.4 kg

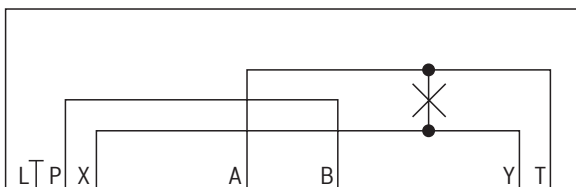

FKM seals

Material no. **R900959377**

Weight: 8.4 kg

Dimensions

Valve mounting screws (included in the scope of delivery)

Size	Quantity	Hexagon socket head cap screws	Material number
25	6	ISO 4762 - M12 x 60 - 10.9 Friction coefficient $\mu_{\text{total}} = 0.09 \dots 0.14$; Tightening torque $M_A = 100 \text{ Nm} \pm 10 \%$	R913015613



Notice:

The tightening torque of the hexagon socket head cap screws refers to the maximum operating pressure.

Subplates (separate order) with porting pattern according to ISO 4401-08-08-0-05 see data sheet 45100.

Accessories (separate order)

Mating connectors and cable sets

Item ¹⁾	Designation	Version	Short designation	Material number	Data sheet
3	Mating connector; for valves with round connector, 6-pole + PE	Straight, metal, PG11	7PZ31...M	R900223890	08006
		Straight, plastic, PG11	7PZ31...K	R900021267	
		Angled, plastic, PG11	7PZ31...K	R900217845	
	Cable sets; for valves with round connector, 6-pole + PE	Plastic, 3.0 m	7PZ31 BF6	R901420483	
		Plastic, 5.0 m		R901420491	
		Plastic, 10.0 m		R901420496	
		Plastic, 20.0 m		R901448068	

¹⁾ See dimensions on page 16.

Test and service devices

Type	Designation	Material number	Data sheet
VT-HDT-1	Service case with test device for proportional servo valves with integrated electronics (OBE)	R996043985	–

Project planning information

► Nominal flow

The nominal flow refers to 100 % of the command value signal at 70 bar pressure differential (35 bar per control edge) and describes the initial slope of the flow signal function of the servo valve. The pressure differential must be observed as a reference.

Other values result in the flow being changed.

Also to be considered is a possible nominal flow tolerance of $\pm 10\%$, as well as a saturation influence (see "Characteristic curves" page 12).

► Control spool overlap

The control spool overlap in % refers to the nominal stroke of the control spool per control edge.

► Pilot oil

Care should be taken that the pilot pressure is as constant as possible. An external pilot control via port X is thus often advantageous.

► Inlet pressure range

Care should be taken that the inlet pressure is as constant as possible. Minimum pilot pressure ≥ 10 bar. The dynamic characteristic curves depend on the inlet pressure.

At an inlet pressure > 40 bar, the pilot pressure must not be less than 60 % of the inlet pressure, otherwise the flow forces on the control spool of the 3rd stage will impair controllability.

For an inlet pressure ≤ 40 bar, a pilot pressure via connection X (external supply) is advantageous.

- Changes in the zero point may result in damage to the system and may only be implemented by instructed specialists.

Further information

- | | |
|--|--|
| ► Hydraulic valves for industrial applications | Data sheet 07600-B |
| ► Directional servo valve with mechanical position feedback | Data sheet 29564 |
| ► Subplates | Data sheet 45100 |
| ► Hydraulic fluids on mineral oil basis | Data sheet 90220 |
| ► Environmentally compatible hydraulic fluids | Data sheet 90221 |
| ► Flame-resistant, water-free hydraulic fluids | Data sheet 90222 |
| ► Flame-resistant hydraulic fluids – containing water (HFAE, HFAS, HFB, HFC) | Data sheet 90223 |
| ► General product information on hydraulic products | Data sheet 07008 |
| ► Mating connectors and cable sets for valves and sensors | Data sheet 08006 |
| ► Information on available spare parts | www.boschrexroth.com/spc |

Notes

Bosch Rexroth AG
Industrial Hydraulics
Zum Eisengießer 1
97816 Lohr am Main, Germany
Phone +49 (0) 93 52/ 40 30 20
my.support@boschrexroth.com
www.boschrexroth.com

© All rights reserved to Bosch Rexroth AG, also regarding any disposal, exploitation, reproduction, editing, distribution, as well as in the event of applications for industrial property rights.
The data specified above only serve to describe the product. As our products are constantly being further developed, no statements concerning a certain condition or suitability for a certain application can be derived from our information. The information given does not release the user from the obligation of own judgment and verification. It must be remembered that our products are subject to a natural process of wear and aging.