

S20 digital input module 16 inputs

R911335972
Edition 02

Data sheet S20-DI-16/4

16 digital inputs
24 V DC
2-, 3-, 4-conductor technology

10 / 2022



1 Description

The module is designed for use within an S20 station. It is used to acquire digital signals.

You can adjust the filter times of the inputs to increase noise immunity.

Filter times of 100 μ s enable you to implement a counter function with a maximum input frequency of 5 kHz in the application.

Features

- 16 digital inputs in accordance with EN 61131-2 type 1 and type 3
- 24 V DC, 2.4 mA
- Connection of sensors in 2-, 3-, and 4-conductor technology
- Filter times can be adjusted in two increments: < 100 μ s or 500 μ s
- Maximum input frequency: 5 kHz
- Maximum permissible load current per sensor: 2 A
- Maximum permissible load current of the module: 4 A (2 A for each group of a max. 8 sensors)
- Minimum update time of < 100 μ s
- Device rating plate stored

Valid from index AC1.



The deviating behavior of the modules with an earlier index is documented in the corresponding points.



This data sheet is only valid in association with the application description for the S20 system, material number R911335988.



Make sure you always use the latest documentation.

It can be downloaded under www.boschrexroth.com/electrics.

2	Table of contents	
1	Description	1
2	Table of contents	2
3	Ordering data	3
4	Technical data	3
5	Internal circuit diagram	7
6	For your safety	7
	6.1 Intended use	7
	6.2 Qualification of users	7
	6.3 Electrical safety	7
	6.4 Installation	7
7	UL note	7
8	Terminal point assignment.....	8
9	Connection example.....	8
10	Local diagnostic and status indicators	9
11	Process data.....	10
12	Parameter, diagnostics and information (PDI)	10
13	Standard objects	11
	13.1 Objects for identification (device rating plate).....	11
	13.2 Miscellaneous standard objects	12
	13.3 Diagnostics state (0018hex: DiagState).....	13
14	Application objects	15
15	Device descriptions	15

3 Ordering data

Description	Type	MNR	Pcs./Pkt.
S20 digital input module 16 inputs	S20-DI-16/4	R911172532	1
Accessories	Type	MNR	Pcs./Pkt.
S20 bus base module	S20-BS	R911172540	5
Connector set	S20-CNS-8L-ORBG/D/UI/E1/E2	R911173858	1
Documentation	Type	MNR	Pcs./Pkt.
Application description S20: System and Installation	DOK-CONTRL-S20*SYS*INS-AP..-EN-P	R911335988	1
Application description S20: Error Messages	DOK-CONTRL-S20*DIAG*ER-AP..-EN-P	R911344826	1

Additional ordering data

For additional ordering data (accessories), please refer to the product catalog at www.boschrexroth.com/electrics.

4 Technical data

Dimensions (nominal sizes in mm)

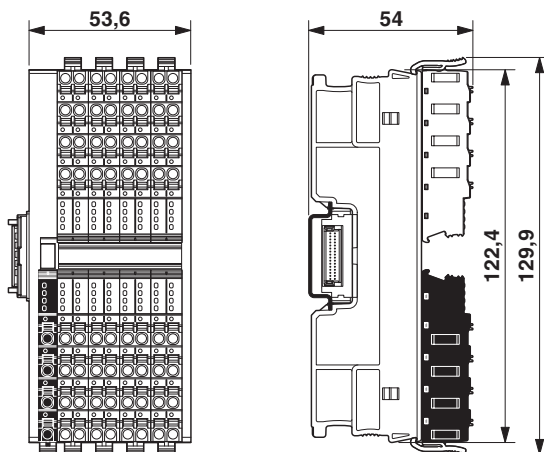

Width	53.6 mm
Height	129.9 mm
Depth	54 mm
Note on dimensions	The depth applies when a TH 35-7.5 DIN rail is used (in accordance with EN 60715).

General data	
Color	light grey RAL 7035
Weight	231 g (with connectors and bus base module)
Ambient temperature (operation)	-25 °C ... 60 °C
Ambient temperature (storage/transport)	-40 °C ... 85 °C
Permissible humidity (operation)	5 % ... 95 % (non-condensing)
Permissible humidity (storage/transport)	5 % ... 95 % (non-condensing)
Air pressure (operation)	70 kPa ... 106 kPa (up to 3000 m above sea level)
Air pressure (storage/transport)	70 kPa ... 106 kPa (up to 3000 m above sea level)
Degree of protection	IP20
Protection class	III (IEC 61140, EN 61140, VDE 0140-1)
Overvoltage category	II (IEC 60664-1, EN 60664-1)
Degree of pollution	2 (IEC 60664-1, EN 60664-1)
Mounting type	DIN rail mounting
Mounting position	any (no temperature derating)
Connection data: S20 connector	
Connection method	Push-in connection
Conductor cross section, rigid	0.2 mm ² ... 1.5 mm ²
Conductor cross section, flexible	0.2 mm ² ... 1.5 mm ²
Conductor cross section [AWG]	24 ... 16
Stripping length	8 mm
Note	Observe the specifications for the conductor cross sections in the application description for the S20 system, material number R911335988.
Interface: Local bus	
Connection method	Bus base module
Transmission speed	100 Mbps
Supply of the local bus (U_{Bus})	
Supply voltage	5 V DC (via bus base module)
Current consumption	max. 120 mA (up to index AB1) max. 60 mA (from index AC1)
Power consumption	max. 600 mW (up to index AB1) max. 300 mW (from index AC1)
Supply for digital input modules (U_I)	
Supply voltage	24 V DC
Supply voltage range	19.2 V DC ... 30 V DC (including all tolerances, including ripple)
Current consumption	typ. 25 mA (without sensors) max. 4 A (Sensor supply U _S)
Power consumption	typ. 600 mW (without sensors) max. 120 W (of which 800 mW with internal losses)
Surge protection	electronic (35 V, 0.5 s)
Reverse polarity protection	parallel diode; with external 5 A fuse (only for commissioning)

Supply for digital input modules (U_I)

Protection	max. 8 A (polarity reversal protection up to 5 A)
------------	---

NOTICE Damage to the electronics

Provide external protection for the module to ensure reverse polarity protection. If you use a fuse, the power supply unit must be capable of supplying four times the nominal current of the fuse. This ensures that the fuse trips reliably in the event of a fault.



When using the module for the first time, protect it with a 5 A fuse. When all modules in the system are correctly connected, the 5 A fuse can be replaced with an 8 A fuse. After that, you can load the module up to 8 A.

Sensor supply (U_S)

Supply voltage	24 V DC (from U_I)
Load current	max. 2 A (per sensor) max. 2 A (per each group of max. 8 sensors) max. 4 A (per each module of 2 groups)
Short-circuit/overload protection	electronic

Digital inputs

Number of inputs	16
Connection method	Push-in connection
Connection technology	2-, 3-, 4-conductor
Description of the input	EN 61131-2 types 1 and 3
Nominal input voltage	24 V DC
Nominal input current	2.4 mA
Current flow	linear until nominal current is reached, then constantly approx. 2.4 mA
Input voltage range "0" signal	-3 V DC ... 5 V DC
Input voltage range "1" signal	11 V DC ... 30 V DC
Input filter time	500 μ s (Default), < 100 μ s
Process data update	< 100 μ s
Polarity reversal protection of the inputs	electronic

Input and output address area

Input address area	2 Byte
Output address area	0 Byte

Configuration and parameter data in a PROFIBUS system

Required parameter data	3 Byte
Required configuration data	6 Byte

Electrical isolation/isolation of the voltage areas

Test section	Test voltage
5 V supply of the local bus (U_{BUS}) / 24 V supply (I/Os)	500 V AC, 50 Hz, 1 min.
5 V supply of the local bus (U_{BUS}) / functional ground	500 V AC, 50 Hz, 1 min.
24 V supply (I/O) / functional ground	500 V AC, 50 Hz, 1 min.

Mechanical tests

Vibration resistance in accordance with EN 60068-2-6/IEC 60068-2-6	5g
Shock in accordance with EN 60068-2-27/IEC 60068-2-27	30g
Continuous shock in accordance with EN 60068-2-27/IEC 60068-2-27	10g

Conformance with EMC Directive 2014/30/EU**Immunity test in accordance with EN 61000-6-2/IEC 61000-6-2**

Electrostatic discharge (ESD) EN 61000-4-2/IEC 61000-4-2	Criterion B, 6 kV contact discharge, 8 kV air discharge
---	---

Electromagnetic fields EN 61000-4-3/IEC 61000-4-3	Criterion A, Field intensity: 10 V/m
--	--------------------------------------

Fast transients (burst) EN 61000-4-4/IEC 61000-4-4	Criterion B, 2 kV
---	-------------------

Transient overvoltage (surge) EN 61000-4-5/IEC 61000-4-5	Criterion B, DC supply lines: ± 0.5 kV/ ± 1.0 kV (symmetrical/ asymmetrical)
---	---

Conducted interference EN 61000-4-6/IEC 61000-4-6	Criterion A, Test voltage 10 V
--	--------------------------------

Noise emission test in accordance with EN 61000-6-3/IEC 61000-6-3	Class B
--	---------

Approvals





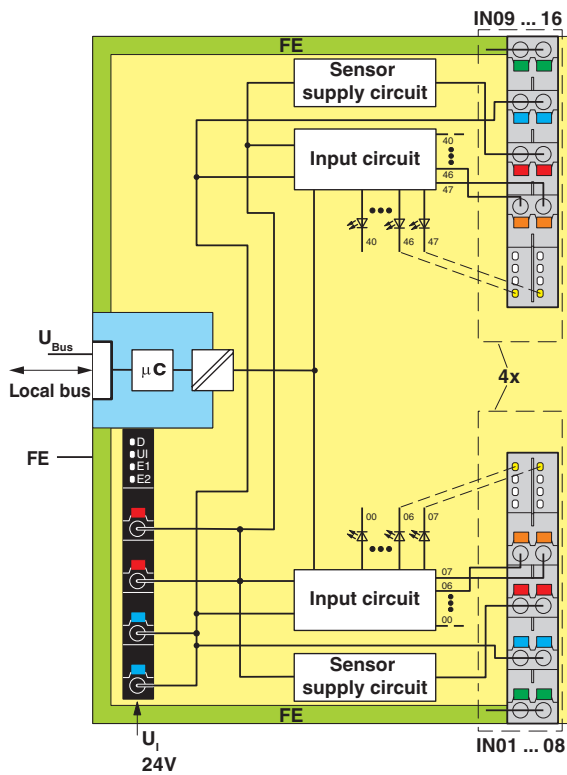

For the current approvals, please visit www.boschrexroth.com/electrics.

5 Internal circuit diagram

Fig. 1 Internal wiring of the terminal points



Key:

- Local bus Local bus
- FE Functional ground
-  Microcontroller
-  Electrical isolation
-  Sensor supply circuit
-  Input circuit
-  LED
-  Electrically isolated areas

6 For your safety

6.1 Intended use

Only use S20 modules in accordance with the information in this data sheet and in the application description for the S20 system, material number R911335988.

6.2 Qualification of users

The use of products described in this data sheet is oriented exclusively to electrically skilled persons or persons instructed by them. The users must be familiar with the relevant safety concepts of automation technology as well as applicable standards and other regulations.

6.3 Electrical safety



WARNING: loss of electrical safety

If used incorrectly, device safety may be impaired.

During installation, startup, and operation, observe the notes in this data sheet and the specifications in the application description for the S20 system, material number R911335988.

6.4 Installation

Only install the S20 modules in a control cabinet or junction box.

The enclosure must meet the requirements regarding the protection against spread of fire according to the following standards:

- EN 61010-1/IEC 61010-1
- UL 61010-1 (for applications with UL approval)

7 UL note

- Use copper conductors only.

8 Terminal point assignment

Fig. 2 Terminal point assignment

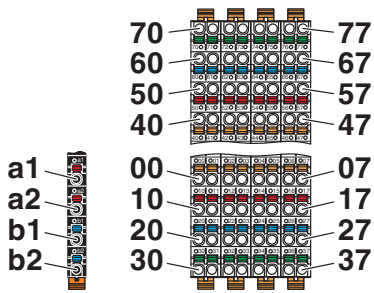

9 Connection example

Fig. 3 Connection in 4- and 3-conductor technology

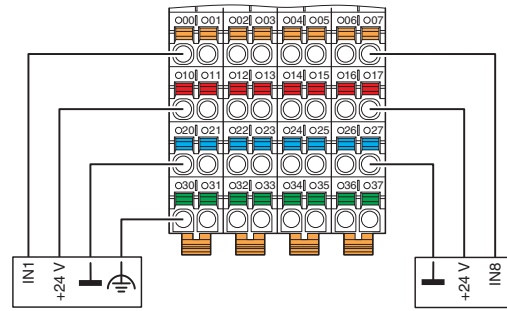

Terminal point	Color	Assignment	
Supply voltage input			
a1, a2	Red	24 V DC (U _I)	Supply for digital input modules (bridged internally)
b1, b2	Blue	GND	Reference potential of the supply voltage (bridged internally)
Digital inputs			
00 ... 07	Orange	IN01 ... IN08	Digital inputs 1 ... 8
40 ... 47	Orange	IN09 ... IN16	Digital inputs 9 ... 16
10 ... 17, 50 ... 57	Red	24 V DC (U _S)	Sensor supply
20 ... 27, 60 ... 67	Blue	GND	Reference potential for all channels
30 ... 37, 70 ... 77	Green	FE	Functional ground

Deviating behavior up to index AB1



E1 and E2 LEDs: Inputs 1 to 8 form group 1, inputs 9 to 16 form group 2. If an error occurs on at least one of the inputs of a group, this will be indicated with the corresponding LED.

Designation	Color	Meaning	State	Description
E1	Red	I/O error in group 1	On	Failure or overload/short circuit of the sensor supply (U_S) group 1.
			Off	No I/O error.
E2	Red	I/O error in group 2	On	Failure or overload/short circuit of the sensor supply (U_S) group 2.
			Off	No I/O error.

11 Process data

The process data is mapped in Motorola format (Big Endian).

IN process data

Byte	0							
Bit	7	6	5	4	3	2	1	0
Signal	IN08	IN07	IN06	IN05	IN04	IN03	IN02	IN01
Terminal point	07	06	05	04	03	02	01	00

Byte	1							
Bit	7	6	5	4	3	2	1	0
Signal	IN16	IN15	IN14	IN13	IN12	IN11	IN10	IN09
Terminal point	47	46	45	44	43	42	41	40

12 Parameter, diagnostics and information (PDI)

Parameter and diagnostic data as well as other information is transmitted as objects via the PDI channel of the S20 station.

In IndraWorks, these parameters are displayed in the configurator.

The standard and application objects stored in the module are described in the following section.

The following applies to all tables below:

For an explanation of the data types, please refer to the application description for the S20 system, material number R911335988.

Abbreviation	Meaning
A	Number of elements
L	Length of the elements in bytes
R	Read
W	Write



Each visible string is terminated with a null terminator (00_{hex}). The length of a visible-string-type element is therefore at least one byte larger than the number of user data items.

If the number of user data items plus null terminator is smaller than the specified length of the element, the visible string will be populated with a null character (00_{hex}).



For detailed information on PDI objects, please refer to the application description for the S20 system, material number R911335988.

13 Standard objects

13.1 Objects for identification (device rating plate)

From index AC1

Index (hex)	Object name	Data type	A	L	Rights	Meaning	Contents
Manufacturer							
0001	VendorName	Visible String	1	32	R	Vendor name	Bosch Rexroth AG
0002	VendorID	Visible String	1	7	R	Vendor ID	006034
0012	VendorURL	Visible String	1	58	R	Vendor URL	http://www.boschrexroth.com
Module - general							
0004	DeviceFamily	Visible String	1	16	R	Device family	I/O digital IN
0006	ProductFamily	Visible String	1	32	R	Product family	IndraControl S20
000E	CommProfile	Visible String	1	4	R	Communication profile	633
000F	DeviceProfile	Visible String	1	5	R	Device profile	0010
0011	ProfileVersion	Record of Visible Strings	2	11; 21	R	Profile version	2011-12-07; Basic - Profile V2.0
0017	Language	Record of Visible Strings	2	6; 8	R	Language	en-us; English
Module - special							
0005	Capabilities	Visible String	1	8	R	Capabilities	Nothing
0007	ProductName	Visible String	1	32	R	Product name	S20-DI-16/4
0008	SerialNo	Visible String	1	22	R	Serial number	xx xx xx xx xx xx xx x (e. g., 7602012346BC125)
0009	ProductText	Visible String	1	58	R	Product text	16 digital inputs
000A	OrderNumber	Visible String	1	32	R	Item No.	R911172532
000B	HardwareVersion	Record of Visible Strings	2	11; 11	R	Hardware version	e.g., 2020-04-26; AA1
000C	FirmwareVersion	Record of Visible Strings	2	11; 11	R	Firmware version	e.g., 2017-12-31; 1.00
000D	PChVersion	Record of Visible Strings	2	11; 6	R	PDI version	e. g., 2010-06-21; V1.00
0037	DeviceType	Octet string	1	8	R	Device type	00 80 00 02 00 00 00 D0 _{hex}
003A	VersionCount	Array of UINT16	4	4 * 2	R	Version counter	e.g., 0007 0001 0001 0001 _{hex}
Use of the device							
0014	Location	Visible String	1	58	R/W	Location	Can be completed by the user.
0015	EquipmentIdent	Visible String	1	58	R/W	Equipment identifier	Can be completed by the user.
0016	AppIDeviceAddr	UINT16	1	2	R/W	Application-specific device address	Can be completed by the user.

Deviating behavior up to index AB1

Index (hex)	Object name	Data type	A	L	Rights	Meaning	Contents
Manufacturer							
0001	VendorName	Visible String	1	17	R	Vendor name	Bosch Rexroth AG
0012	VendorURL	Visible String	1	28	R	Vendor URL	http://www.boschrexroth.com
Module - general							
0006	ProductFamily	Visible String	1	17	R	Product family	IndraControl S20
0011	ProfileVersion	Record of Visible Strings	2	11; 20	R	Profile version	2011-12-07; Basis - Profil V2.0
003A	VersionCount	Array of UINT16	4	4 * 2	R	Version counter	e.g., 0007 0001 0000 0000 _{hex}
Module - special							
0007	ProductName	Visible String	1	12	R	Product name	S20-DI-16/4
0008	SerialNo	Visible String	1	16	R	Serial number	xx xx xx xx xx xx xx x (e. g., 7602012346BC125)
0009	ProductText	Visible String	1	18	R	Product text	16 digital inputs
000A	OrderNumber	Visible String	1	11	R	Item No.	R911172532
000B	HardwareVersion	Record of Visible Strings	2	11; 4	R	Hardware version	e.g., 2020-04-26; AA1
000C	FirmwareVersion	Record of Visible Strings	2	11; 3	R	Firmware version	0000-00-00; --

13.2 Miscellaneous standard objects

Index (hex)	Object name	Data type	A	L	Rights	Meaning/contents
Diagnostics objects						
0018	DiagState	Record	6	58	R	Diagnostic state *
Objects for process data management						
0025	PDIN	Octet string	1	2	R	Input process data The structure corresponds to the representation in the "Process data" section.

The objects identified with * in the last column are described in more detail in the following sections.

The description of the other objects is to be found in the application description for the S20 system, material number R911335988.

13.3 Diagnostics state (0018_{hex}: DiagState)

This object is used for a structured message of an error.

From index AC1

0018 _{hex} : Diagnostics state (read)					
Subindex	Data type	Length in bytes	Meaning	Contents	
0	Record	58	Diagnostic state	Complete diagnostics information	
1	UINT16	2	Error number	0 ... 65535 _{dec}	
2	UINT8	1	Priority	00 _{hex}	No error
				01 _{hex}	Error
				02 _{hex}	Warning
				81 _{hex}	Error removed
				82 _{hex}	Warning eliminated
3	UINT8	1	Channel/group/module	00 _{hex}	No error
				01 _{hex}	Group 1 (inputs 1 to 8)
				02 _{hex}	Group 2 (inputs 9 to 16)
				FF _{hex}	Entire device
4	UINT16	2	Error code	See table below	
5	UINT8	1	More follows	00 _{hex}	
6	Visible String	51	Text	See table below	

 The message with priority 81_{hex} or 82_{hex} is a one-off, internal message to the bus coupler. The bus coupler transfers this error message to the error mechanisms of the higher-level system.

 After the error has been eliminated, it is automatically reset.

Error and status of the local diagnostics and status indicators

Subindex	2	3	4	6	LED			
	Priority	Channel/ group/ module	Error code	Text	D	UI	E1	E2
	hex	hex	hex					
No error	00	00	0000	Status OK	●	●	○	○
Failure of the supply for digital input modules (U _I)	01	FF	3412	Missing I/O supply UI, terminal point a1/a2, b1/b2	✱	○	●	○
Sensor supply overload or short circuits (U _S) for inputs 1 to 8 (group 1)	01	01	2211	Overload / short circuit sensor supply 1 ... 8	●	●	○	●
Sensor supply overload or short circuits (U _S) for inputs 9 to 16 (group 2)	01	02	2211	Overload / short circuit sensor supply 9 ... 16	●	●	○	●



Off



On



Green on



Flashing green/yellow

Deviating behavior up to index AB1

0018 _{hex} : Diagnostics state (read)					
Subindex	Data type	Length in bytes	Meaning	Contents	
0	Record	8	Diagnostic state	Complete diagnostics information	
1	UINT16	2	Error number	0 ... 65535 _{dec}	
2	UINT8	1	Priority	00 _{hex}	No error
				01 _{hex}	Error
				02 _{hex}	Warning
				81 _{hex}	Error removed
				82 _{hex}	Warning eliminated
3	UINT8	1	Channel/group/module	00 _{hex}	No error
				01 _{hex}	Group 1 (inputs 1 to 8)
				02 _{hex}	Group 2 (inputs 9 to 16)
				FF _{hex}	Entire device
4	UINT16	2	Error code	See table below	
5	UINT8	1	More follows	00 _{hex}	
6	Visible String	1	Text	00 _{hex}	

The error codes are identical to those in index AC1.

Error text is not specified.

Subindex	2	3	4	LED			
Error	Priority	Channel/group/module	Error code				
	hex	hex	hex	D	UI	E1	E2
No error	00	00	0000	●	●	○	○
Failure of the supply for digital input modules (U _I)	01	FF	3412	⚡	○	○	○
Sensor supply overload or short circuits (U _S) for inputs 1 to 8 (group 1)	01	01	2211	●	●	●	○
Sensor supply overload or short circuits (U _S) for inputs 9 to 16 (group 2)	01	02	2211	●	●	○	●



Off



On



Green on



Flashing green/yellow

14 Application objects

In the case of valid parameters, the parameterization is stored in the module permanently.

Index (hex)	Object name	Data type	A	L	Rights	Meaning/contents
FF8F	Input_Filter	UINT8	1	1	R/W	Filter time

Filter time (FF8F_{hex}: Input_Filter)

You parameterize the filter time of the module with this object.

FF8F _{hex} : Input_Filter (read, write)					
Subindex	Data type	Length in bytes	Contents		
0	UINT8	1	00 _{hex} (Default)	500 µs	
			01 _{hex}	< 100 µs	

15 Device descriptions

The device is described in the device description files.

These files are available for download at www.boschrexroth.com/electrics in the download area of the bus coupler used.

DOK-CONTRL-
S20*DI*16*4-DA02-EN-P

Bosch Rexroth AG
Bgm.-Dr.-Nebel-Str. 2
97816 Lohr a.Main
Germany
Tel. +49 9352 18 0
Fax +49 9352 18 8400
www.boschrexroth.com/electrics

All rights reserved. No part of this document may be reproduced or stored, processed, duplicated, or circulated using electronic systems, in any form or by any means, without the prior written authorization of Bosch Rexroth AG, Electric Drives and Controls. Violations shall give rise to claims for damages. The data specified above only serve to describe the product. They do not indicate any specific condition or suitability for a certain application. It must be remembered that our products are subject to natural wear and ageing.