

Electric power control EPC

Application software for electric vehicles



The eLION portfolio with inverters, motors, onboard chargers and DCDC converters enables flexible combinations for many applications. The application software Electric power control EPC is used to operate the high voltage system, charge the battery and distribute the power to various consumers. The control of the 12/24V power supply is also provided.

EPC from Bosch Rexroth is suitable for a wide range of mobile working machines with battery-electric drive - from construction, agricultural and forestry machines to municipal and material handling machines.

CUSTOMER BENEFITS

- Reduced development effort with proven solutions
- Comprehensive performance management
- Global charging solution
- Combination of the software products Travel drive control EDA and Pump drive control PDC
- Integration of additional drives
- Open interfaces to various thermal management and high voltage battery manufacturers
- Features for electrical safety

FUNCTION AND BENEFITS

Fast development thanks to pre-validated systems

The high voltage system is the base of a drive system development. EPC integrates the coordinated eLION components of the high voltage system, provides the necessary features and is fully validated. The application software runs on the Bosch Rexroth RC5-6/40 control unit, which connects the various participants in the high voltage system.

Optimized performance management for higher performance

The integrated power management with an extensive feature portfolio makes it possible to distribute the power available in the machine to the individual consumers. Pre-validated priority groups and performance distribution principles are available for this purpose. The machine can always be operated at the maximum available power.

Control of electrical drives

With auxiliary drive, Electric power control EPC offers a control function for electric drives that are integrated into the high voltage system but are actuated by another control unit based on the setpoint value specifications. EPC receives the setpoint value specification and auxiliary drive takes over communication with the inverter. This enables the vehicle manufacturer to concentrate fully on the drive's operating strategy.

APPLICATIONS

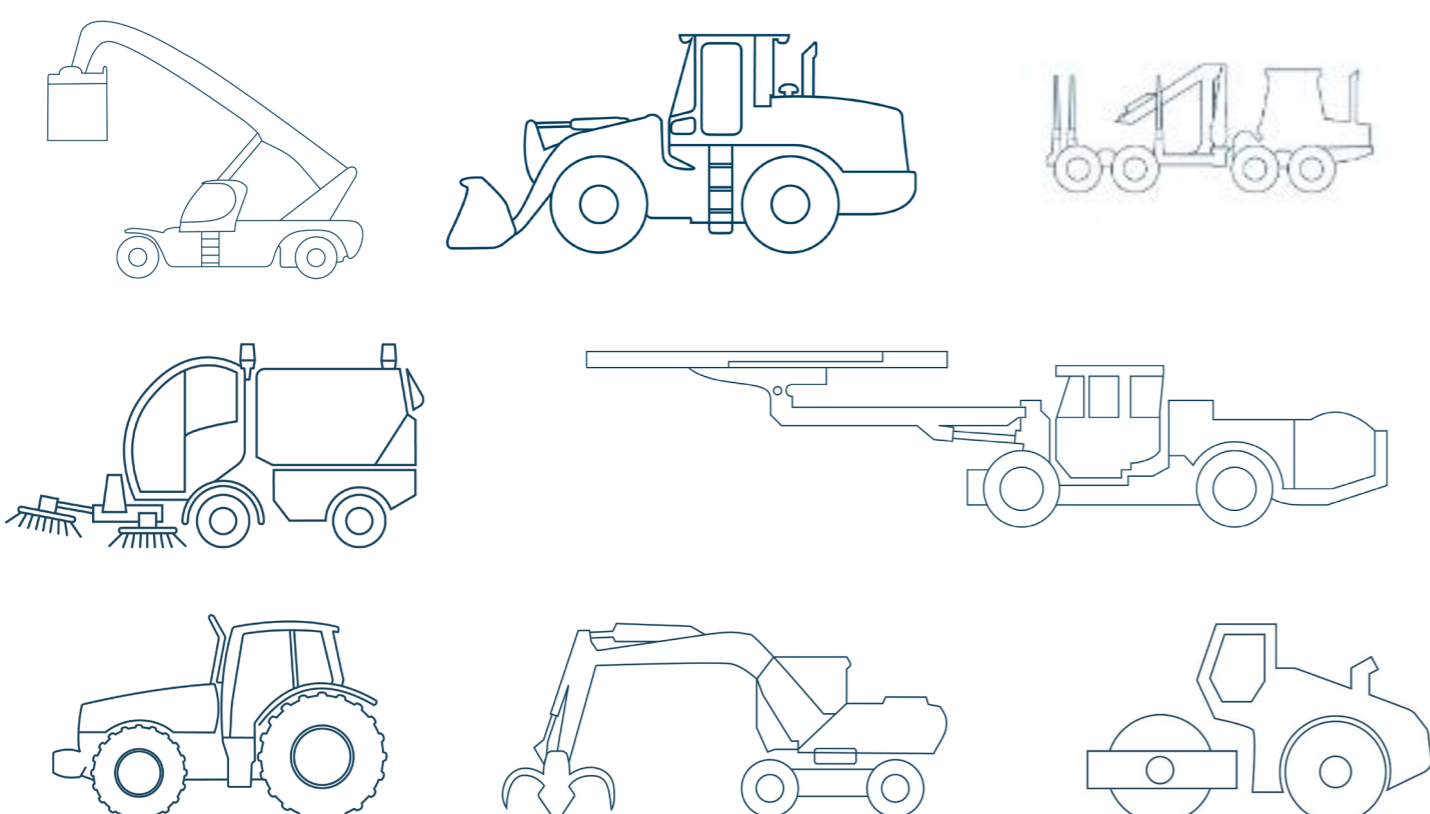

TECHNICAL DATA

Electric power control EPC	
Inverters:	eLION EDS1
Motors:	eLION EMS1/EMP1
DCDC converters:	eLION EDCC1
Onboard chargers:	eLION EOBC1
BODAS application software interfaces to:	<ul style="list-style-type: none"> • Pump drive control PDC • Travel drive control EDA
Battery management system interface:	customer-specific
Thermal management system interface:	customer-specific
Insulation monitoring device:	customer-specific
High voltage interlock monitoring:	optional
Communication interface:	CAN SAE J1939
BODAS control unit:	RC5-6/40
Safety standards:	prepared for EN ISO 13849
Diagnostic Interface:	BODAS-service and CAN SAE J1939 (UDS)

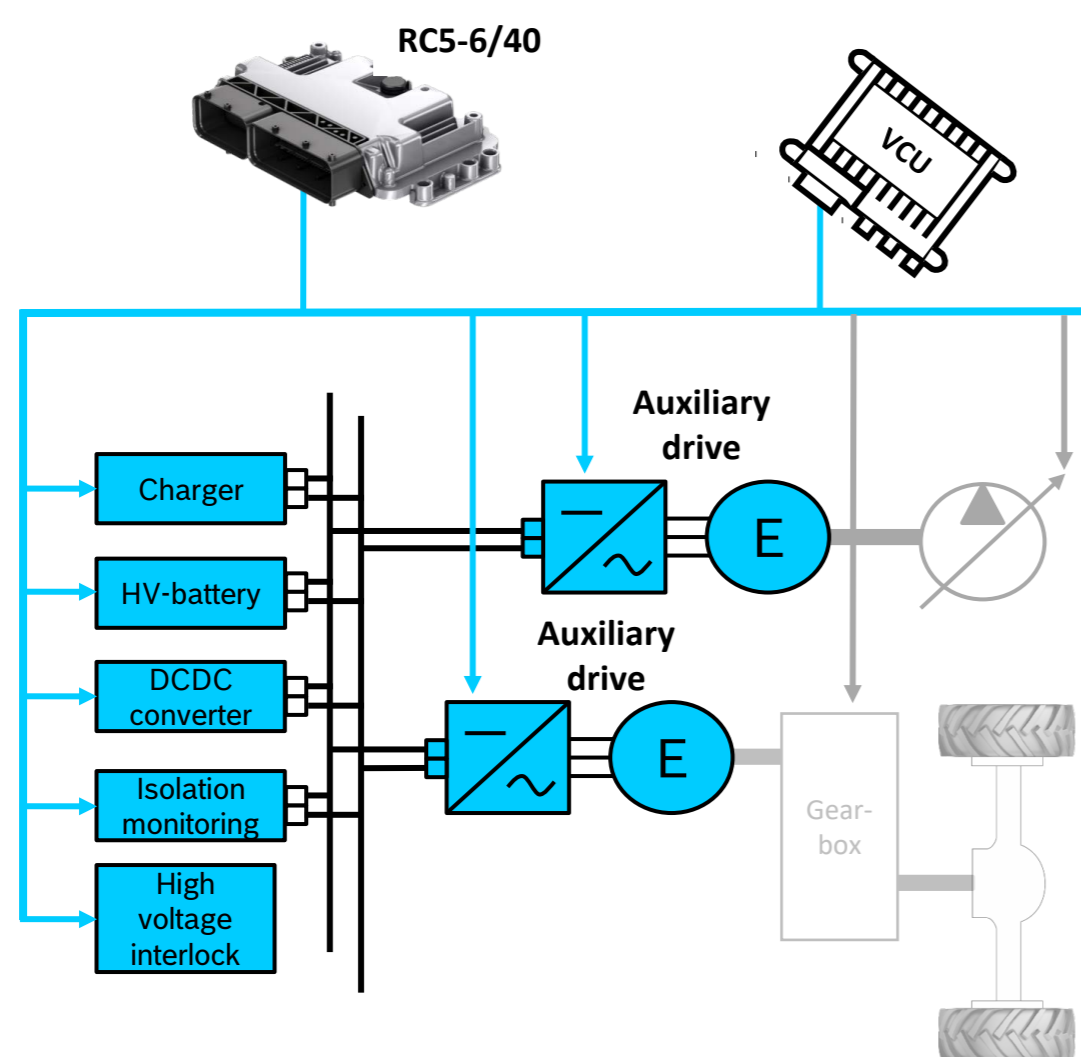

Integration of the Electric power control EPC into a high voltage system

Interface to Travel drive control EDA and Pump drive control PDC

EPC has been developed with the BODAS tools and according to BODAS architecture. This is why the communication interfaces for the software products Travel drive control EDA and Pump drive control PDC have been coordinated. This allows these software products to be combined easily.

Global charging solution

The application software Electric power control EPC offers an extensive range of features for battery charging. In addition to AC charging and DC charging in accordance with CCS1 and CCS2 standard, the standardized communication interface of the EOBC1 charger enables the mobile machine to be charged on a three-phase or single-phase network. Charging directly with a CEE connector enables a high degree of flexibility on various areas of operation, e.g. construction sites. Various charging cable locking options allow the system to be adapted to different requirements.

Open to various thermal management system and high voltage battery manufacturers

EPC supports communication with various battery management and thermal management systems. Thanks to a generic interface, the communication interface can be implemented quickly and easily.

Features for electrical safety

The application software EPC supports the use of a high voltage interlock circuit and the integration of an insulation monitoring device. EPC can monitor the high voltage interlock circuit, integrate the isolation monitoring device or import the corresponding status values via CAN communication.