

ctrlX I/O

System and Installation



Copyright

© Bosch Rexroth AG 2025

All rights reserved, also regarding any disposal, exploitation, reproduction, editing, distribution, as well as in the event of applications for industrial property rights.

Disclaimer

The data specified above only serve to describe the product. As our products are constantly being further developed, no statements concerning a certain condition or suitability for a certain application can be derived from our information. The information given does not release the user from the obligation of own judgment and verification. It must be remembered that our products are subject to a natural process of wear and aging.

Table of contents

1	About this application manual	6
1.1	Revision history.....	6
1.2	Scope of validity.....	6
1.3	Related documents.....	6
1.4	Customer feedback.....	6
2	Product identification	7
3	For your safety	7
3.1	User qualification.....	7
3.2	Electrical safety.....	8
4	Intended use	8
5	ctrlX product group	8
5.1	ctrlX I/O - Modular I/O system.....	8
5.2	Design of a ctrlX I/O station.....	9
5.3	Product description.....	10
6	ctrlX devices at a glance	11
6.1	ctrlX CORE control.....	11
6.2	EtherCAT bus coupler.....	13
6.3	Input and output modules.....	14
6.4	System modules XI8.....	15
6.5	ctrlX I/O module types and article name.....	15
7	Voltage concept	16
7.1	Electrical isolation.....	17
7.1.1	Setup with electrical isolation.....	17
7.1.2	Setup without electrical isolation.....	18
7.2	Voltage boost.....	18
7.3	Segmentation.....	19
7.4	Multi-wire technique.....	19
7.5	GND-FE binding.....	20
8	Housing variants, design and dimensions	20
8.1	Basic design.....	20
8.1.1	EtherCAT bus coupler.....	20
8.1.2	I/O module.....	21
8.1.3	Mounting rail holder.....	21

8.2	Dimensions of the ctrlX I/O modules.	22
8.2.1	EtherCAT bus coupler.	23
8.2.2	12 mm and 20 mm modules.	24
8.3	Peripheral plug.	25
8.3.1	Basic design.	25
8.3.2	Pusher colors.	25
8.3.3	Variants and dimensions.	26
9	Transporting, storing and unpacking	26
9.1	Transporting.	26
9.2	Storing.	27
9.3	Unpacking.	27
9.4	Ambient conditions.	27
10	Module mounting	28
10.1	Basic information on mounting.	28
10.2	Mounting and installation	29
10.3	Maximum number of passive modules.	30
10.4	Mounting ctrlX I/O module.	30
10.5	Positioning peripheral plug.	31
10.6	Removing peripheral plug.	32
10.7	Dismounting module.	33
11	Electric installation	33
11.1	Notes on the electrical connection.	33
11.1.1	Tools.	34
11.1.2	Permitted lines.	34
11.1.3	Wire end ferrules.	34
11.1.4	Orientation of the wire end ferrules.	34
11.1.5	Installing lines.	35
11.1.6	Uninstalling lines.	35
11.1.7	Mounting notes for UL certification.	35
11.2	Connecting voltage supply.	36
11.2.1	Dimensioning voltage infeed	36
11.2.2	Logic voltage supply.	36
11.2.3	Peripheral voltage supply.	37
11.3	Connecting EtherCAT network to the bus coupler.	37

12	Grounding and shielding	38
12.1	Grounding.....	38
12.1.1	Functional earth (FE).....	38
12.1.2	Potential equalization.....	38
12.2	Shielding.....	38
12.2.1	Shield set.....	39
13	Spare parts and accessories	44
13.1	RJ45 cable.....	44
13.2	End clamp.....	44
13.3	End cover.....	44
13.4	Shield connection.....	44
14	Standards and approvals	44
14.1	General information.....	44
14.2	Standards used.....	44
14.3	CE conformity.....	45
14.4	UKCA conformity.....	45
14.5	UL/CSA-certified.....	45
15	Diagnostic and status displays	46
15.1	Diagnostic mechanisms.....	46
15.2	Diagnosis history.....	47
15.2.1	Status codes in the Diagnosis History.....	48
15.3	NET status LED.....	48
15.4	Channel status LED.....	49
16	Commissioning	49
16.1	IT security.....	49
16.2	Device description files ESI.....	49
16.3	Parameterizing modules.....	49
16.4	Writing "Configured Station Alias".....	49
17	License information	49
17.1	EtherCAT®.....	49
18	Disposal	50
19	Service and support	51
	Index	52

1 About this application manual

1.1 Revision history

Table 1: Editions of this documentation

Edition	Release date	Note
Edition 01	2024-05	First edition
Edition 02	2025-07	Voltage concept and further information added

1.2 Scope of validity

This application manual is valid for all ctrlX I/O modules whose type code starts with:

- XB-xx-xx
- Xlxxxxxx

1.3 Related documents

Title	Part number and document type
Security Manual	➔ R911342562
Electric Drives and Controls	Project Planning Manual
ctrlX I/O Modules	➔ ctrlX I/O Data sheets
ctrlX I/O Engineering	Application Manual
Field Bus Configuration for ctrlX CORE	Also refer to: ➔ https://docs.automation.boschrexroth.com/iirds/cdp-metadata.boschrexroth.de~iiDC~Product-ctrlX-IO-Engineering/

1.4 Customer feedback

Customer requests, comments or suggestions for improvement are of great importance. Please email your feedback on the documentations to ➔ Feedback.Documentation@boschrexroth.de. Directly insert comments into the electronic PDF document and send the PDF file to Bosch Rexroth.

2 Product identification

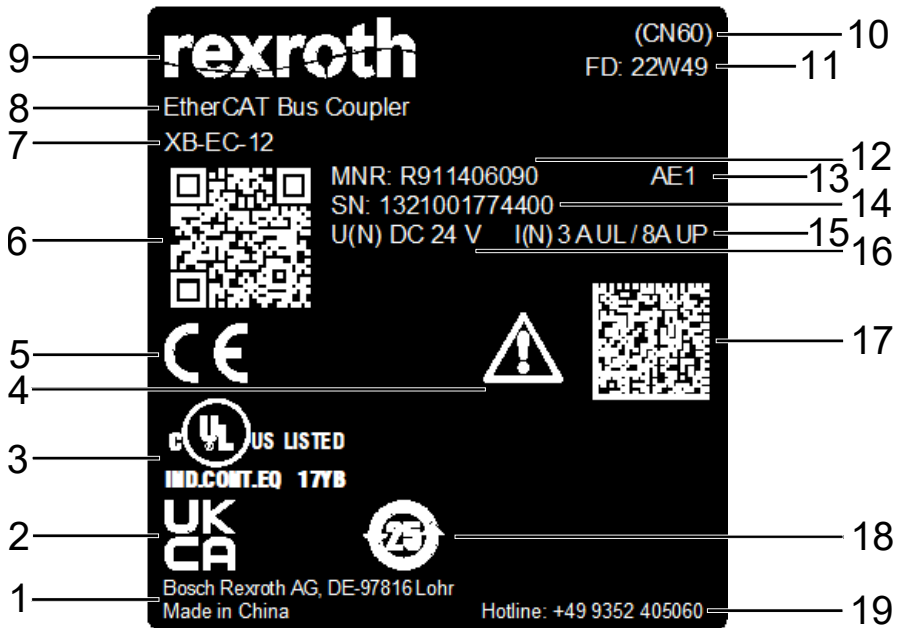

Fig. 1: Type plate (example)

- | | | | |
|---|--|----|--|
| 1 | Company address | 10 | Plant number |
| 2 | UKCA marking | 11 | Manufacturing date |
| 3 | Underwriters Laboratories Inc. mark | 12 | Part number |
| 4 | Symbol for reference to the operating instructions | 13 | State of revision |
| 5 | CE conformity mark | 14 | Serial number |
| 6 | QR or data matrix code, Rexroth, 2D code | 15 | Rated voltage |
| 7 | Type code | 16 | Rated current |
| 8 | Product | 17 | Data Matrix code or MAC code (2D code) |
| 9 | Trademark | 18 | China-RoHs 2 label |
| | | 19 | Service hotline number |

3 For your safety

3.1 User qualification

The product use described in this application manual is only intended for qualified electricians and staff trained by these qualified electricians. The user has to be familiar with the known safety concepts on automation technology, applicable standards and other guidelines.

3.2 Electrical safety

NOTICE

Loss of electric safety

Unintended handling can affect the device safety! Observe the notes in the present data sheet during installation, commissioning and operation.

4 Intended use

NOTICE

Risk of damaging the device if not expressly stated accessories, mounting parts and other components, cables, lines, software and firmware are used.

The ctrlX I/O modules may exclusively be used with the accessories and add-on components specified in this documentation. Components that are not expressly mentioned must neither be attached nor connected. The same applies to cables and lines.

Operation may only be carried out with the hardware component configurations and combinations that are expressly specified.

Typical areas of application of the modules:

- Handling and assembly systems
- Packaging and food processing machines
- Printing and paper converting machines
- Machine tools
- Wood working machines
- General mechanical engineering
- Building automation in the industrial sector

⚠ WARNING

Danger due to unintended use

The protection specified by Bosch Rexroth cannot be ensured if not used as intended.

- Use the product exclusively as intended by Bosch Rexroth.
- Operate this device only under the mounting and installation conditions, in the position and under the ambient conditions (temperature, degree of protection, humidity, EMC etc.) specified in the respective data sheet.

5 ctrlX product group

5.1 ctrlX I/O - Modular I/O system

With ctrlX I/O from Bosch Rexroth, there are completely new options for connectivity and networking. The I/O portfolio is used for horizontal and vertical integration and also represents a functional extension of the ctrlX CORE control platform. This provides users with comprehensive communication and performance extensions, as well as I/O modules with regard towards future technologies such as 5G, TSN and AI.

Key features of ctrlX I/O at a glance:

- Compact: 50% less control cabinet requirement
- Flexible and unlimited topologies
- EtherCAT up to the module
- Quick and easy commissioning
- Perfectly matched to ctrlX CORE
- Future-proof
- Integrating own modules

5.2 Design of a ctrlX I/O station

A ctrlX I/O station consists of individual modules snapped onto an earthed support rail. The head of the station is a control or a bus coupler. The I/O modules are connected to the control or the bus coupler. The individual modules are connected to each other and to the station head using an integrated jumper plug.

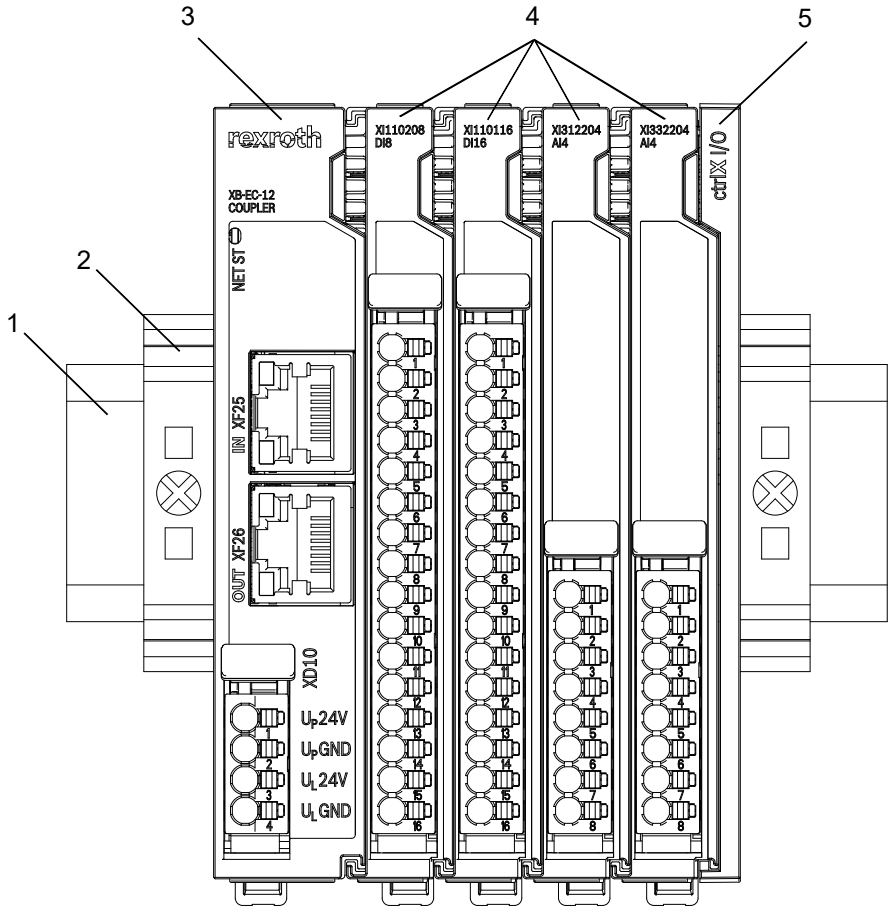

Fig. 2: Design of a ctrlX IO station

- ① Support rail
- ② End clamps (to fix the station)
- ③ EtherCAT bus couplers
- ④ ctrlX I/O input or output modules
- ⑤ Endcover



For detailed information on function, properties, wiring and parameterization, refer to the module-specific documentation.

5.3 Product description

I/O modules with various functions are available within the ctrlX I/O product group.

The ctrlX I/O modules consist of an electronic module and a peripheral plug.

The well thought-out ergonomic mechanical design and push-in technology enable simple tool-free installation and quick replacement of modules without having to disconnect a conductor from the peripheral plug.

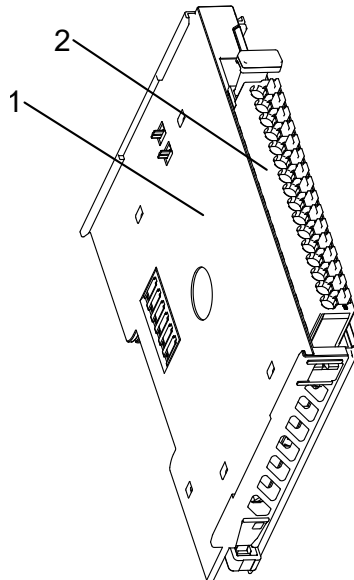

Fig. 3: Exemplary module, 12 mm

- ① Electronics module
- ② Peripheral plug

6 ctrlX devices at a glance

6.1 ctrlX CORE control

The ctrlX CORE compact control in embedded format is suitable for the mounting rail mounting and for its use in a control cabinet.

The various ctrlX CORE models are available in several performance classes and provide sufficient computing power for the most demanding control tasks. The Linux-based operating system is open for the integration of all ctrlX CORE Runtime and ctrlX CORE Engineering apps from the ctrlX WORKS function module kit and other further customized apps. A central ctrlX Data Layer is used to exchange the communication between the apps in realtime and non-realtime.

The onboard EtherCAT master is used to connect and control the drives, I/O modules and other devices from the open EtherCAT ecosystem.

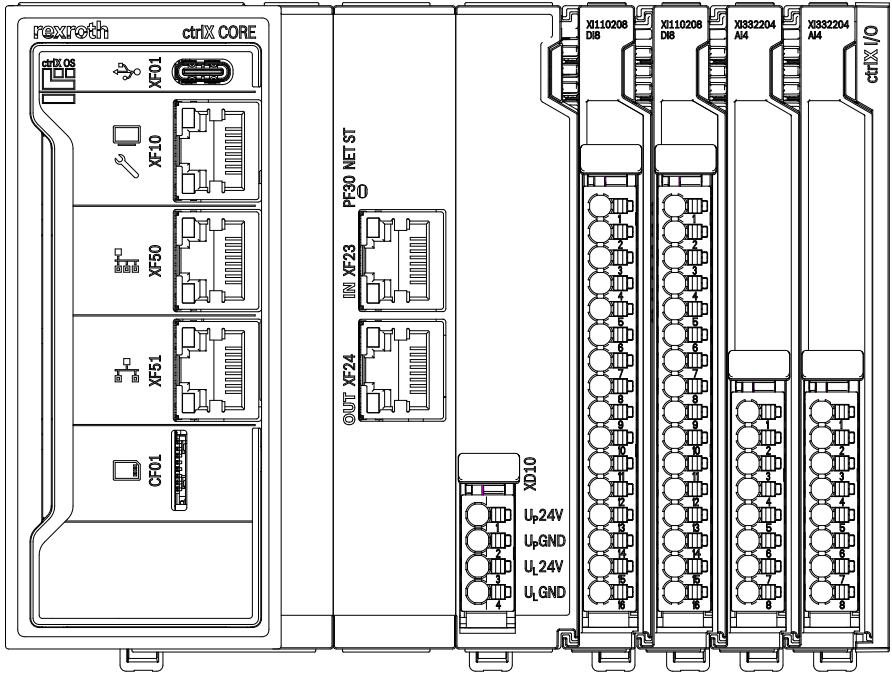

Fig. 4: Device overview, ctrlX CORE^{plus} X3, including I/O modules

6.2 EtherCAT bus coupler

The bus coupler XB-EC-12 connects the EtherCAT network and the ctrlX I/O system. The bus coupler supplies the connected I/O modules with the logic voltage U_L and the peripheral voltage U_P .

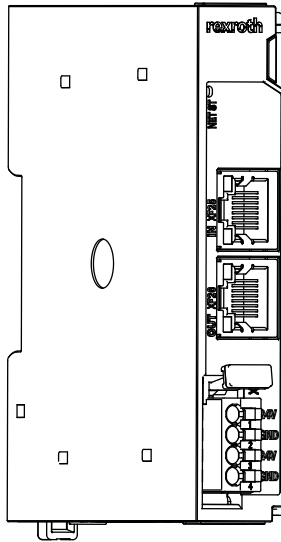

Fig. 5: EtherCAT bus couplers

6.3 Input and output modules

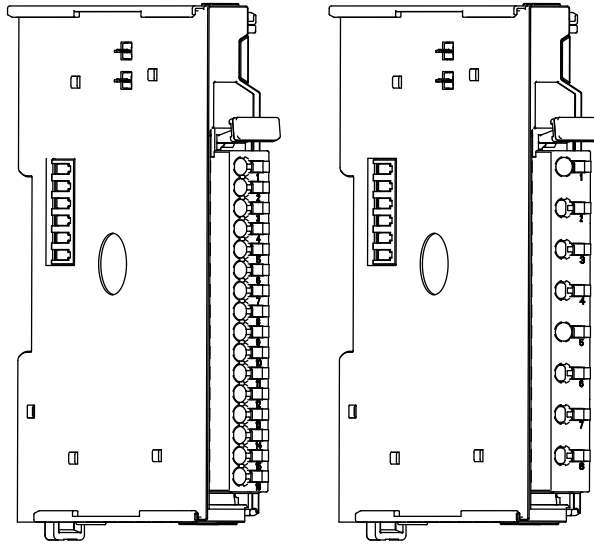

Fig. 6: Exemplary view DO16 and DOR2

The ctrlX I/O modules provide the interface function for the system, e.g. the following:

- Digital input and output modules
- Analog input and output modules
- Communication modules
- Function modules

The modules listed are active modules, i.e. they are EtherCAT devices. Process data is therefore exchanged via the local bus.

6.4 System modules XI8

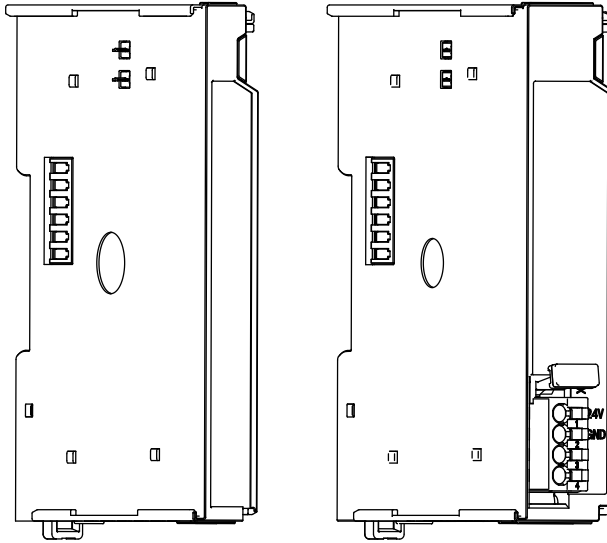

Fig. 7: 12 mm empty housing module; 20 mm boost module

System module provide specific functions within a ctrlX I/O station:

- Voltage boost or segmentation
- Potential distribution
- Empty housing

Some of the modules listed are passive modules, i.e. they are not EtherCAT devices and therefore do not exchange process data. Please refer to the product-specific data sheet.

6.5 ctrlX I/O module types and article name

	Name	Detailing	Example
XB-xx-xx	Bus modules	EtherCAT bus coupler or decoupling, number of ports	XB-EC-12 EtherCAT Bus coupler
XI1xxxx	Digital input modules	4-, 8-, 16-channel PNP, NPN, counter, timestamping or oversampling 24 V DC 1-, 2-wire	XI110116 16Ch. Dig. Input 24V 3ms
XI2xxxx	Digital output modules	4-, 8-, 16-channel PNP, NPN, relay, PWM or oversampling 24 V DC 1-, 2-wire	XI210116 16Ch. Dig. Output 24V/0.5A

	Name	Detailing	Example
XI3xxxx	Analog input modules	4-channel Measuring range Resolution	XI312204 4Ch. Ana. Input 0-10V 16Bit
XI4xxxx	Analog output modules	2-, 4-channel Output range Resolution	XI412204 4Ch. Ana. Output 0-10V 16Bit
XI5xxxx	Communication modules	1-, 2-, 4-channel IO-Link, RS485, RS232, MBUS	XI521001 1Ch. Serial RS232
XI6xxxx	Function modules	Encoder interface	XI613101 1Ch. Encoder Inc TTL
XI8xxxx	System modules	Voltage boost, potential distribution	XI821116 16Ch. Potential distribution GND

7 Voltage concept

A ctrlX I/O station consists of at least one voltage-supplying module (bus coupler or ctrlX CORE^{plus}) and multiple consumers (I/O modules).

There are two main power supply rails: U_L for the logic supply and U_P for the peripheral supply. U_L and U_P are galvanically isolated from each other.

Current is supplied centrally via a ctrlX I/O bus coupler or a boost module. Refer to the module-specific documentation. The circuitry of a station always has to be closed. The circuitry starts and ends at the same voltage-feeding module. No other voltage sources may be connected to the circuitry!

The U_L logic supply (24 V) is filtered and passed through to the I/O modules on the right. Depending on the current consumption of the connected modules, the U_L logic supply is sufficient for up to 30 modules and the maximum power requirement of 3 A is sufficient, see [Chapter 7.2 “Voltage boost” on page 18](#).

The peripheral supply U_P is filtered and then fed to the I/O modules. The input has no internal protection against overcurrent. Up to 8 A per station can be drawn from the pins U_{OUT} 24 V and GND without a new peripheral boost.

NOTICE

Electronic damages

An overcurrent protective device with a maximum rating of 10 A must be fitted when the device is installed, e.g:

- main circuit breaker acc. to UL489(*) (B-, C-, D-, K- or Z-characteristics)
- Class CC or Class J fuse acc. to UL248(*)

The overcurrent protective devices marked with ""*"" should be used in installations complying with UL standards.

7.1 Electrical isolation

7.1.1 Setup with electrical isolation

Provide electrical isolation between the logic supply U_L and the periphery supply U_P of the I/O modules acc. to DIN EN 60204-1. Accordingly, the voltage U_L (24 V logic voltage) at the ctrlX I/O station is electrically isolated from the peripheral voltages U_P (24 V segment voltage).

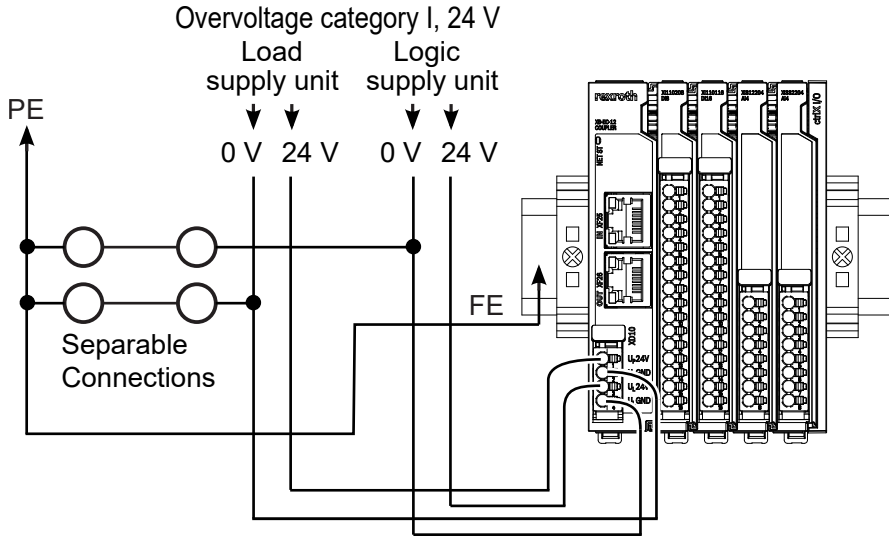

Fig. 8: Setup with electrical isolation

7.1.2 Setup without electrical isolation

Overtoltage category I, 24 V

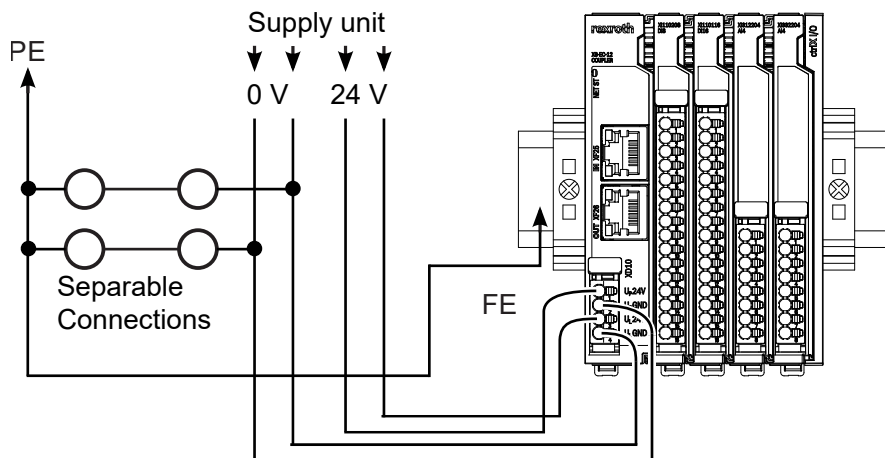

Fig. 9: Setup without electrical isolation



The station does not start in case of reverse input voltage.

The 24 V feeding U_L and U_P at the XD10 connector is protected against polarity reversal. A polarity reversal of U_L and GND U_L feeding as well as U_P and GND U_P feeding does not damage the device. However, the station does not start and the status displays are not on.

7.2 Voltage boost

The peripheral power supply U_P is designed for a maximum power requirement of 8 A. The logic supply U_L is also designed for a maximum power requirement of 3 A and a maximum of 30 modules.

Before these limits are exceeded, the voltages has to be fed in again.

Various modules are available for voltage boost. The peripheral supply can be boosted with all modules. The logic supply can only be boosted with the XI813101 module.

Ordering code	Part number	Description
XI811101	R911406093	Passive voltage boost module for the peripheral circuitry (U _P) 24 V DC 8 A
XI812101	R911406094	Active voltage boost module for the peripheral circuitry (U _P) 24 V DC 8 A with integrated voltage and current measurement
XI813101	R912009610	Voltage boost module for the peripheral circuitry (U _P) 24 V DC / 8 A and logic circuit (U _L) 3 A with integrated voltage and current measurement

The boost modules galvanically isolate the peripheral voltage from that of the preceding modules, thus allowing segmentation.



An external overcurrent protection device is required for each U_P boost!



The U_L power supply has to be delivered from the same power supply unit as the U_L power supply on the bus coupler or on the control unit.

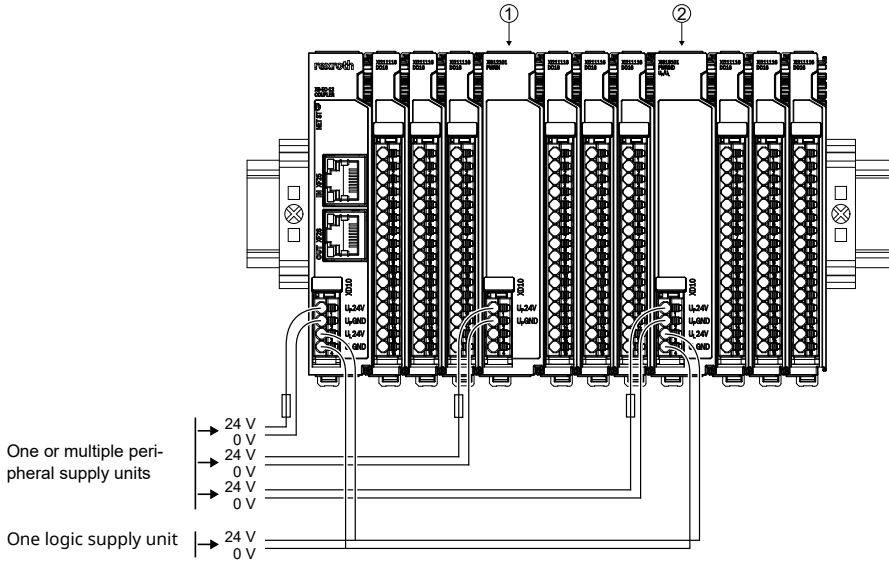

Fig. 10: Exemplary setup with voltage boost

- ① Voltage boost U_P
- ② Voltage boost U_L and U_P

7.3 Segmentation

Multiple segments with galvanically isolated peripheral supply areas can be created using a voltage supply boost module for the peripheral circuitry, which is connected to an isolated current supply.

An external overcurrent protection device is required for each U_P segmentation!

7.4 Multi-wire technique

The multi-wire technique provides U_{OUT} 24 V and U_{OUT} GND in various extension stages. U_{OUT} 24 V is the filtered peripheral supply potential U_P 24 V. U_{OUT} GND is the filtered peripheral reference potential U_P GND.



- The U_{OUT} 24 V outputs are only to be used as switching potential to the respective input.
- These outputs may not be used as peripheral voltage supply.
- To supply the connected actuators, use the potential distribution modules, e.g. XI822116.

7.5 GND-FE binding

There is no direct GND-FE binding. GND is only connected to FE via a resistor and capacitor network.

8 Housing variants, design and dimensions

8.1 Basic design

8.1.1 EtherCAT bus coupler

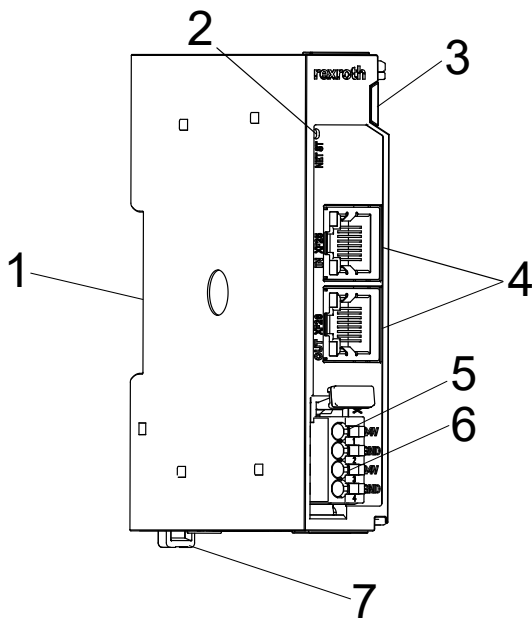

Fig. 11: XB-EC-12

- | | |
|---|------------------------|
| ① Mounting rail holder | ⑤ Voltage supply U_P |
| ② PF30 NET ST LED | ⑥ Voltage supply U_L |
| ③ Module status display | ⑦ Locking lever |
| ④ EtherCAT interfaces: IN (XF25) and OUT (XF26) | |

8.1.2 I/O module

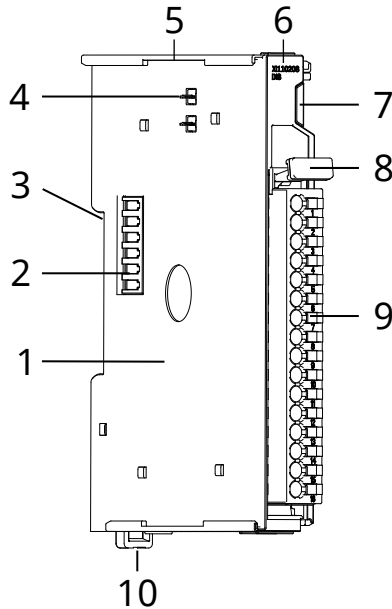

Fig. 12: Electronics module 12 mm

- | | |
|------------------------|----------------------------|
| ① Electronics module | ⑥ Type code and short name |
| ② Patch connector | ⑦ Module status display |
| ③ Mounting rail holder | ⑧ Locking lever |
| ④ Power contacts | ⑨ Peripheral plug |
| ⑤ Guide rail | ⑩ Locking lever |

8.1.3 Mounting rail holder

The mounting rail holder is identical for all ctrlX I/O modules.

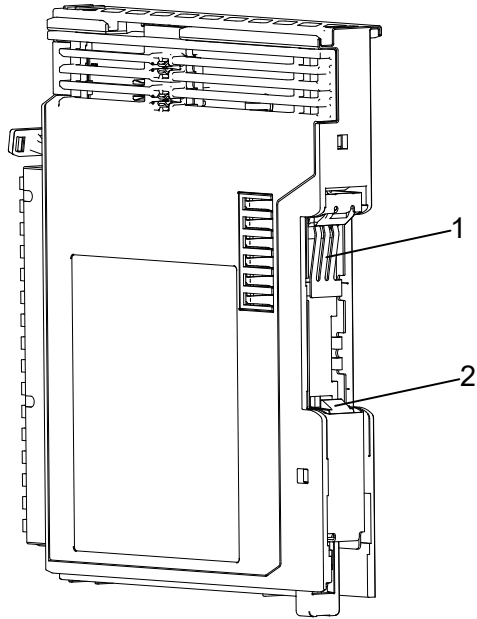

Fig. 13: Mounting rail holder and FE connection

- ① FE connection
- ② Engagement of the mounting rail holder

8.2 Dimensions of the ctrlX I/O modules

All following dimensions are given in mm.

8.2.1 EtherCAT bus coupler

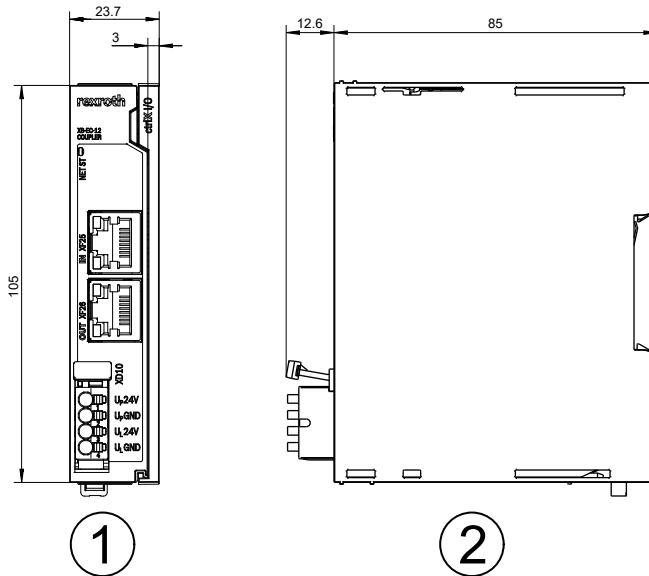

Fig. 14: Bus coupler with endcover

- ① Front view
- ② Side view

8.2.2 12 mm and 20 mm modules

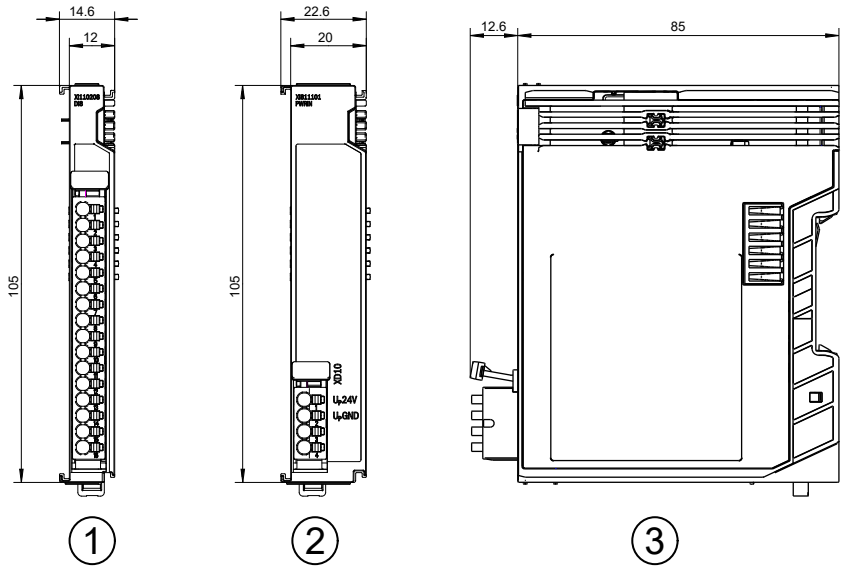

Fig. 15: 12 mm module and 20 mm module

- ① Front view of the 12 mm module
- ② Front view of the 20 mm module
- ③ Side view

8.3 Peripheral plug

8.3.1 Basic design

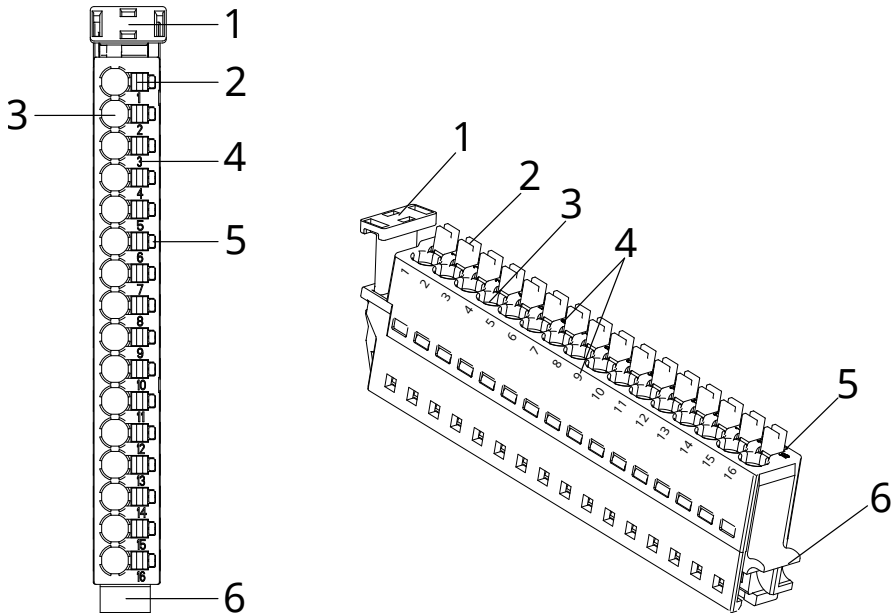

Fig. 16: Design of the peripheral plug

- ① Locking lever
- ② Pusher
- ③ Clamping point
- ④ Clamping point labeling
- ⑤ Status display
- ⑥ Rotary axis

8.3.2 Pusher colors

Color	RAL color	Function of the clamping point
Light gray	RAL 7035	Function clamping point
Red	RAL 3020	Voltage supply 24VDC
Blue	RAL Design 230 50 35	Voltage supply GND
Dark red	RAL 3003	U_{OUT} 24 V DC (more exact function depends on the module)
Dark blue	RAL Design 240 20 22	U_{OUT} GND (more exact function depends on the module)

Green	RAL Design 130 60 40	FE
Yellow	RAL 1018	Safety function clamping point

8.3.3 Variants and dimensions

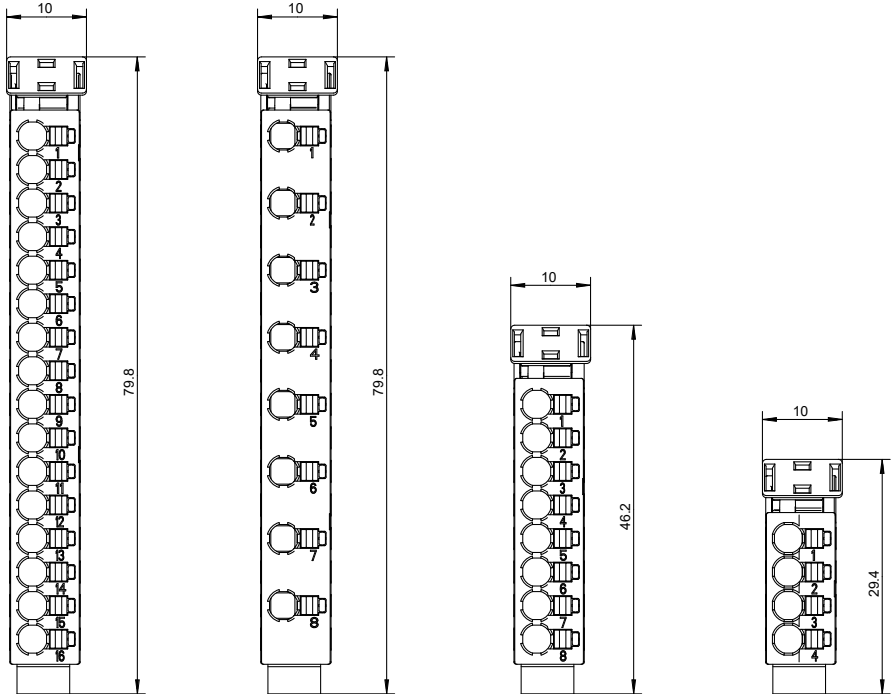

Fig. 17: Dimensions of various peripheral plugs

9 Transporting, storing and unpacking

9.1 Transporting

NOTICE

Electrostatic discharge!

Electrostatic discharge can damage or destroy components. Comply with the required safety measures against electrostatic discharge (ESD) acc. to EN 61340-5-1 and IEC 61340-5-1 when handling the module.

ctrlX I/O modules are packaged in a folding box. Observe the handling instructions on the packaging. Only transport the modules in their original packaging or in packaging suitable for transportation.

During transportation, observe the information in the product-specific data sheet regarding humidity and temperature range.

9.2 Storing

The storage location has to meet the following conditions:

- Dry
- Protected from external influences
- Protected from harmful environmental influences such as UV light

When storing, observe the information in the product-specific data sheet in the technical data on environmental conditions such as temperature range, air pressure and humidity.

9.3 Unpacking

Read the package insert carefully before installing and using the device. Keep the package insert in a safe place.

Check the delivery for damage and completeness. Make a complaint about any transport damage immediately.

Product insert

- Scope of delivery for the bus coupler:
ctrlX I/O bus coupler with attached peripheral plug, mounted endcover and package insert.
- Scope of delivery for a standard module:
ctrlX I/O module with attached peripheral plug (if available) and package insert.

9.4 Ambient conditions

To ensure trouble-free operation, observe the ambient conditions specified in the data sheet.

NOTICE

Defective device due to contaminated air!

- The ambient air must not contain acids, alkaline solutions, corrosive agents, salts, metal vapors and other electrically conductive contaminants in high concentrations.
- The devices to be installed into the housings and installation compartments must at least comply with the degree of protection IP 54 according to DIN EN 60529.
- The device shall be provided in a suitable fire enclosure in the end-use application.

NOTICE

Defective device due to gases jeopardizing functions

Due to the risk of corrosion, avoid sulphureous gases (e.g. sulphur dioxide (SO₂) and hydrogen sulphide (H₂S)). The device is not resistant against these gases.

NOTICE**Defective device due to overheating**

To avoid overheating and to ensure a trouble-free operation of the device, the ambient air has to circulate. Also refer to the section "Installation notes".

10 Module mounting

10.1 Basic information on mounting

Note the following mounting instructions

- **Module sequence:**

You can connect the ctrlX I/O modules to the bus coupler in any order within a segment circuit. To ensure the function, connect the modules in series without gaps.

If you are using modules with a shield connection, we recommend installing them next to each other to optimally use the busbar for the shield connection, see also [↔ Chapter 12.1 "Grounding and shielding" on page 38](#).

- **Maximum number of modules:**

The maximum number of ctrlX I/O modules within a station without backfeeding the logic voltage U_L is 30. For larger stations, a backfeed of the logic voltage U_L has to be used, even if the available logic current has not yet been used up.

The following factors can limit the actual number of modules within a ctrlX I/O station:

- The provided logic current.
- The current consumption of the connected modules.
- The system limits of the bus coupler.

See also [↔ Chapter 7 "Voltage concept" on page 16](#).

- **Current supply and current consumption:**

The bus coupler supplies the current supply for the local bus U_L and the peripheral supply U_P . The total current consumption of U_L and U_P of all ctrlX I/O modules supplied in the station must not exceed the maximum currents according to the module-specific data sheet of the power supply (bus coupler, boost module). The current consumption of the logic and peripherals are specified for each module in the module-specific data sheet as "Current consumption U_L " and "current consumption U_P ".

When the maximum current consumption is reached, use a boost module, see also [↔ Chapter 7 "Voltage concept" on page 16](#).

- **Maximum number of mating cycles**

The ctrlX I/O modules are designed for up to 50 mating cycles for peripheral plugs, patch connectors, power plugs and FE contacts. In addition, contact problems can result, which can also be caused by corrosion of the damaged contact points over a longer period of time.

NOTICE**Damaging contacts**

Mechanical overstress of the clamping points can damage them.
Provide strain relief for the connected cables.

10.2 Mounting and installation

NOTICE

Device destruction due to electrostatic discharge

The device contains components that can be damaged or destroyed by electrostatic discharge. Comply with the required safety measures against electrostatic discharge (ESD) acc. to EN 61340-5-1 when operating the module.

- Mounting location

The module has the degree of protection IP 20 and is thus intended for use in a closed control cabinet or control box (terminal box) with the degree of protection IP 54 or higher. The control cabinet fulfills the function of the final safety enclosure. The modules must be installed in the final safety enclosure. They have to be provided with sufficient rigidity according to UL 61010-1, 61010-2-201 and have to meet the requirements with regard to fire propagation.

- End clamps

Fasten end clamps of the type SUP-M01-ENDHALTER (R911170685) on both sides of the station. End clamps ensure the correct fastening on the support rail and are used as lateral end elements. Always fasten one end clamp of the station before mounting the station. This ensures the following:

- It impedes the shifting of the modules
- The installation place for the end clamp is secured.

- Endcover

At the end of each ctrlX I/O station, slide an endcover of type XACC-2-END-COVR onto the last module. The endcover is included in the scope of delivery of the bus coupler. Sliding on the endcover ensures protection against accidental contact.

- Mounting rail

Mount the module on a 35 mm standard support rail. Only use a support rail TH 35-7.5 acc. to EN 60715. The fastening distance of the mounting rails may not exceed 200 mm. This distance is required to ensure stability while mounting and dismounting the module.

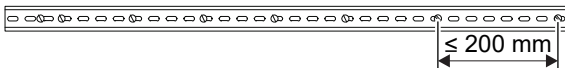

- Provide the following minimum distances for sufficient cooling:

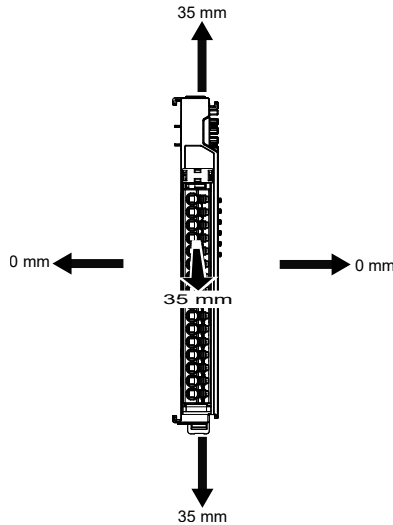

Fig. 18: Ventilation distances

- Additionally, provide sufficient distance for mounting, dismounting, plugs and cables.
- If more devices are connected in series to the station on the left or right, the surface temperature may not exceed 60° C
- In case of a several line design, the supply air has to be measured under each line and its limit value may not be exceeded. For permitted values, refer to the chapter "Ambient conditions" of the respective module data sheet.

10.3 Maximum number of passive modules

Passive modules are not devices at the bus. This means that the bus signals are not processed in these modules.



To ensure the transmission quality, up to three passive modules may be plugged in one after the other. Subsequently, at least one active module with a local bus device has to be installed again before the next passive module may be set.

10.4 Mounting ctrlX I/O module

⚠ WARNING

Possible personal injury during plug assembly under voltage

For voltages outside SELV/PELV, the plug may only be mounted or dismounted in a de-energized state.

Observe the notes in the module data sheet.

NOTICE	<p>Damage of the device by plug mounting under voltage!</p> <p>Disconnect the module and all connected module components from voltage before mounting or dismounting.</p>
NOTICE	<p>Damage of the device by short circuit of patch connectors</p> <p>There is an endcover on the right upon delivery of the bus coupler. Remove this endcover to connect the modules at the bus coupler in series. Position the endcover on the last module of the station to protect it against short circuit and contamination.</p>
NOTICE	<p>Possible damage to property due to unintended mounting of the mounting rail</p> <ul style="list-style-type: none"> – Connect the mounting rail to a functional earth. – Mount the module on a mounting rail. – Install the module in a control cabinet or in an appropriate housing.
NOTICE	<p>Module is not fixed correctly due to open mounting rail fixture!</p> <p>Before mounting, ensure that the mounting rail fixture of the control is not clamped in open position. If required, release the clamping using the locking lever as shown in the following figure.</p>

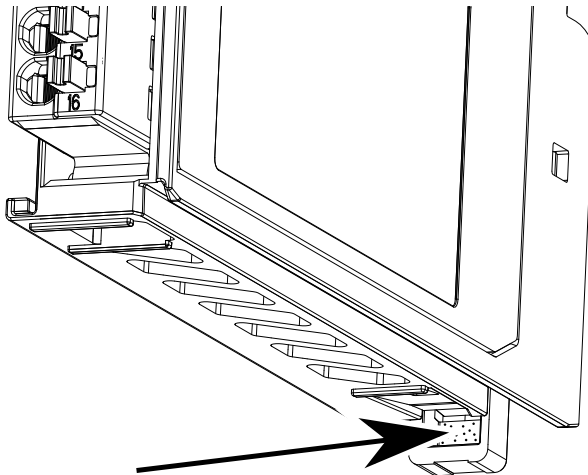

Fig. 19: Locking lever to release the clamping of the open position.
Each module has to be snapped separately.

10.5 Positioning peripheral plug

1. → Position the peripheral plug on the peripheral plug holder, see ①.

2. → The peripheral plug engages at the locking lever, see ②

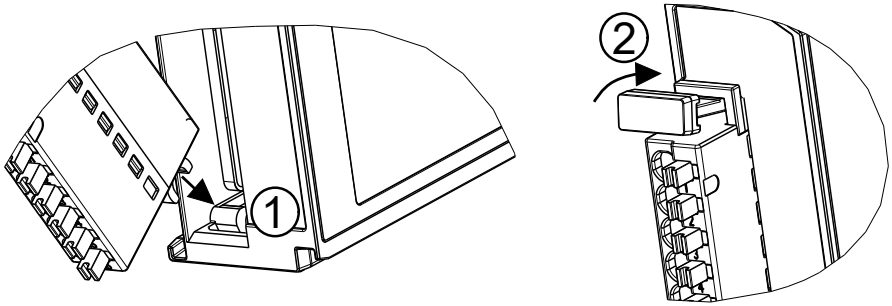

Fig. 20: Positioning peripheral plug

10.6 Removing peripheral plug

1. → Press the locking lever of the peripheral plug, see ①.
2. → Remove the peripheral plug, see ②.

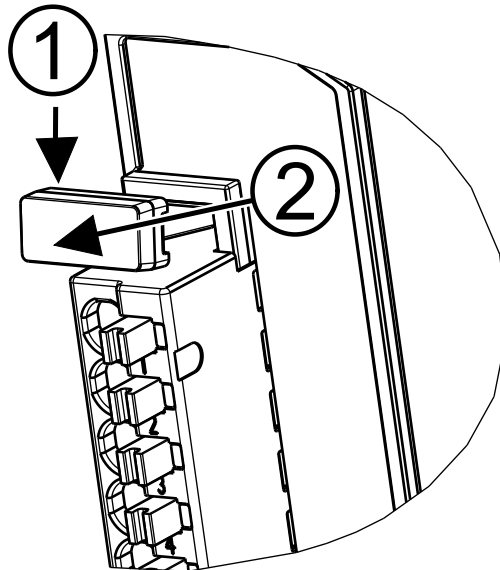

Fig. 21: Removing peripheral plug

10.7 Dismounting module



For dismounting, use a common tool such as a slotted screwdriver with a 2.5 mm blade.

NOTICE

Destruction of components and devices due to mounting and dismounting under voltage!

Disconnect the module and all connected module components from voltage before mounting or dismounting.

Removing module from mounting rail

1. Use a suitable tool (e.g. slotted screwdriver) and put it into the lower disengaging mechanism (base latch) of the module and disengage the module (see ① in the following figure). The base latch is locked in open position.
2. Remove the module vertically to the mounting rail [see ② in the following figure].

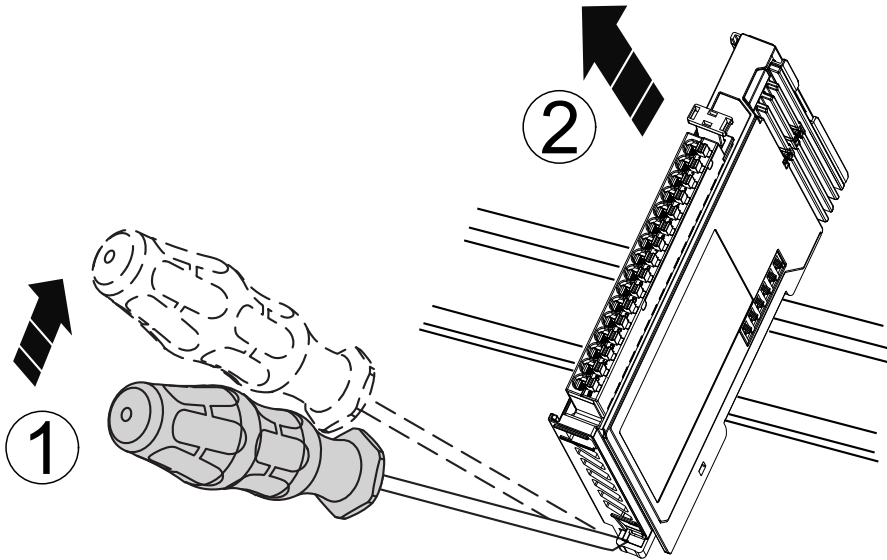

Fig. 22: Dismounting module



Before mounting the module on the mounting rail again, release the clamping of the open position again. Press the locking lever, refer to the figure Fig. 19.

11 Electric installation

11.1 Notes on the electrical connection

- To avoid EMC interferences due to loop formation, 24 V voltage potential and ground (GND) have to be connected in star shape from the 24 V power supply unit to the connections for logic voltage (U_L) and peripheral voltage (U_P).
- Use only insulated copper wires suitable for at least 75 °C.

11.1.1 Tools

- Use the "Phoenix Crimpfox 6" crimping plier to crimp wire end ferrules. The ordering number is: "1212034 Crimpfox 6" at Phoenix Contact.
- Use a slotted screwdriver with a 2.5 mm blade.

11.1.2 Permitted lines

- Rigid lines
Stripping length: 8.5 mm \pm 0.5 mm, burr-free
- Flexible line without wire end ferrule
Stripping length: The length of the stripped and 360° twisted braids has to be 8.5 mm \pm 0.5 mm
- Flexible line with wire end ferrule
- Use a cable cross-section corresponding to the current (minimum 0.2 mm², maximum 1.5 mm²) to avoid an excessive increase in temperature. A cable cross-section of 1.5 mm² is specified for the power supply (U_P) of 8 A. The minimum cable cross-section for the power supply (U_L) is 0.75 mm².
- The insulation of the cables used has to correspond to the rated voltage.

11.1.3 Wire end ferrules

- Wire end ferrules with and without insulating collar are permitted with a contact length of 8 mm according to DIN 46228.
- Maximum dimensions of the crimped wire end ferrule:
Height 1.45 mm
Width 2.34 mm
- Twin wire end ferrules are not permitted.

11.1.4 Orientation of the wire end ferrules

- The orientation of the wire end ferrule in the clamping point has to be vertical.

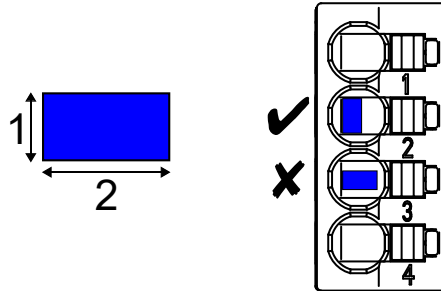

Fig. 23: Orientation of the wire end ferrules in the clamping point

- 1 Height of the crimped wire end ferrule
- 2 Width of the crimped wire end ferrule

11.1.5 Installing lines

- Press the pusher with a suitable slotted screwdriver.
- Insert the line into the clamping point as far as possible.
- Release the pusher.

11.1.6 Uninstalling lines

- Press the pusher with a suitable slotted screwdriver.
- Remove line.
- Release the pusher.

11.1.7 Mounting notes for UL certification

Permitted lines

- Use flexible lines with wire end ferrules for UL devices.
- The following wire end ferrules are permitted:
 - Wire end ferrules with insulating collar as per the table:

Cable cross-section in AWG	Cable cross-section mm ²	Ordering numbers of the wire end ferrules (Weidmüller company)
24 AWG	0.2 mm ²	9025760000, 500 pieces
22 AWG	0.35 mm ²	9025770000, 500 pieces
20 AWG	0.5 mm ²	0690700000, 500 pieces
		1476230000, 100 pieces
18 AWG	0.75 mm ²	0462900000, 500 pieces
		1476240000, 100 pieces

-	1 mm ²	0463000000, 500 pieces
		1476250000, 100 pieces
16 AWG	1.5 mm ²	0463100000, 500 pieces
		1476270000, 100 pieces

Orientation of wire end ferrules

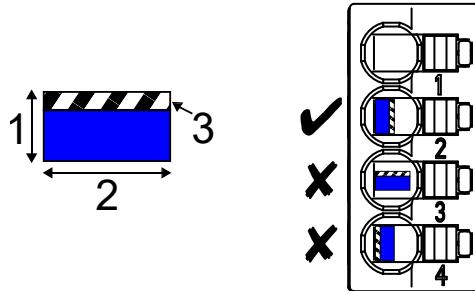

Fig. 24: Orientation of the wire end ferrules in the clamping point

- 1 Height of the crimped wire end ferrule
- 2 Width of the crimped wire end ferrule
- 3 Crimped side of the wire end ferrule

11.2 Connecting voltage supply

The voltage supply for logic and peripherals is provided via the front connector. Logic and peripheral voltages are galvanically isolated internally. Both inputs have reverse polarity protection.

11.2.1 Dimensioning voltage infeed

Observe the maximum currents when dimensioning the voltage infeed. The operating voltage allowed has to be applied directly to the device.

The voltage must also not be exceeded if:

- there are variations in mains voltage, e.g. caused by different loads of the mains
- there are varying load states, such as short-circuit, normal load, lamp load or no load

11.2.2 Logic voltage supply

The logic voltage and logic current are monitored in the bus coupler. The measured values are provided via the EtherCAT bus.



In case of overvoltage or undervoltage of U_L , all modules connected to the segment circuit are switched off.

11.2.3 Peripheral voltage supply

The peripheral voltage is measured in the bus coupler and forwarded directly to the I/O modules. The input has no internal protection against overcurrent.

NOTICE

Electronic damages

An overcurrent protective device with a maximum rating of 10 A must be fitted when the device is installed, e.g:

- main circuit breaker acc. to UL489(*) (B-, C-, D-, K- or Z-characteristics)
- Class CC or Class J fuse acc. to UL248(*)

The overcurrent protective devices marked with "*" should be used in installations complying with UL standards.

11.3 Connecting EtherCAT network to the bus coupler

Connect the EtherCAT to the bus coupler via an 8-pin plug.

The EtherCAT connections are direction-dependent.

Name	Direction	Note
XF25	IN	Line connection from the direction of the master.
XF26	OUT	Line connection in the direction of further slaves.



Autocrossover

Both Ethernet interfaces are provided with the "Autocrossover" function.



Shielding

The shield of the connectable twisted-pair wires is electroconductive and connected to the socket. When connecting net segments, avoid ground loops, accidental energization and potential equalization currents via the shielding braid.



Observe bending radii

The housing dimensions under "Dimensions" refer to the bus coupler with peripheral plugs without Ethernet connection. When installing the bus coupler into a control cabinet, observe the bending radii of the Ethernet cables and the plug connectors used.

To observe the bending radii, use angled RJ45 plugs.



Installing Ethernet cable

The Ethernet cable must not be installed or routed outside the building.

Table 2: EtherCAT interface

Connection method	RJ45 socket ("autonegotiation" and "autocrossing")
Transmission rate	100 MBit/s (full duplex)
Cycle time	125 us min., 10 ms max.
Transmission physics	Ethernet in RJ45-Twisted-Pair
Transmission length	100 m max.

12 Grounding and shielding

12.1 Grounding

NOTICE

Failure due to insufficient grounding

An optimum grounding is required to impede possible interferences from the ctrlX I/O modules and to discharge them to the ground.

12.1.1 Functional earth (FE)



Only the functional earth (FE) is used for the device. The functional earth is only used to discharge disturbances. For individuals, the functional earth is not intended as protection against electric shock.

The ctrlX I/O modules are grounded via the mounting rail. The mounting rail, on which the ctrlX I/O modules are mounted, has to be mounted to a grounded metal carrier, e. g. the rear panel of the control cabinet.

The individual ctrlX I/O modules have FE springs (metal clips) on the rear, which create an electrical connection to the mounting rail during installation. The mounting rail has to be grounded. If required, it has to be provided with a separate grounding connection.

To ensure reliable functional earthing, ensure a correct installation, see [↗ Chapter 10.1 “Basic information on mounting”](#) on page 28.

12.1.2 Potential equalization

Potential equalization acc. to DIN VDE 0100 part 540 has to be provided between the system parts and the voltage supply.

12.2 Shielding

NOTICE

Failure due to insufficient shielding

Provide sufficient shielding.

The shielding reduces any effects of interferences on the system.

Check the module-specific data sheet to see whether shielding is required.

Observe the following when shielding:

- Attach the shield as large as possible.
- Ensure proper contact between connector and module.
- Avoid damaging or squeezing conductors.
- Note the wire specifications when connecting the shielding.
- Shield the closest possible to the signal clamping points. The signal cables should only be routed the shortest possible without shielding.
- Connect the cable shielding to the functional earth immediately after entering the control cabinet. Route the cable with its shielding up to the module.



Route all power cables and data cables in separate cable channels.

12.2.1 Shield set

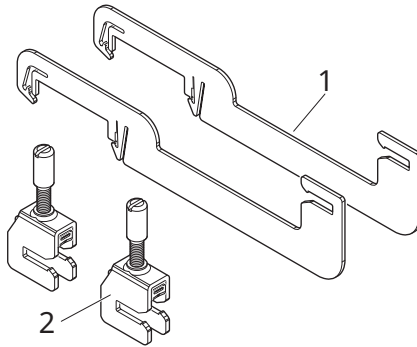

Fig. 25: Shield set

- ① Shield rail holder (2 pieces)
- ② SK 5 shield connection clamps to attach the bus bar to the shield rail holder (2 pieces)

For the best connection of the shielding directly in front of the module, the shield connection set (R911173030) is provided together with the bus bar (R911173283).

The shields are connected to the bus bar with shield clamps (both accessories).

Mounting

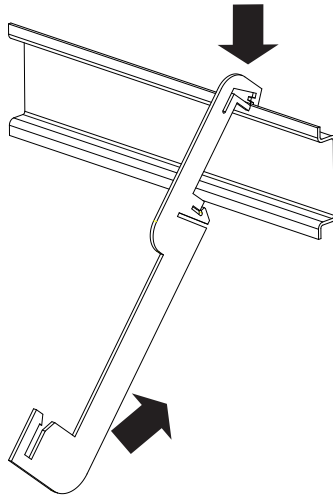

Fig. 26: Engaging shield set

Mount the shield rail holders after mounting the ctrlX I/O modules.

Ensure that the endcover was pushed onto the last module before fitting the shield rail holder.

1. → Engage the shield rail holder.

One shield rail holder is mounted to the left of the I/O station, a second to the right of the station. They are always mounted between the I/O module and the end holder.

2. → Engage the shield rail holder on the mounting rail.

3. → Mount bus bar.

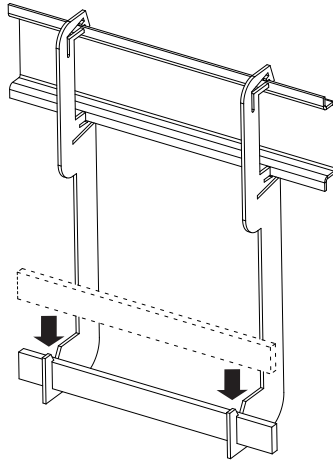

4. → Fix bus bar.

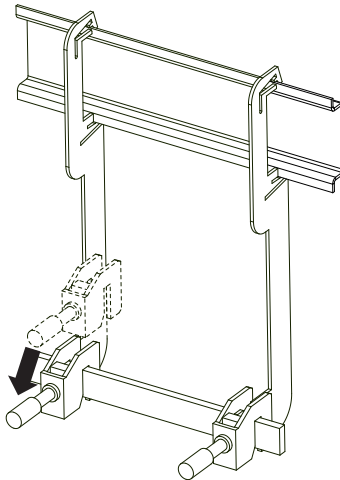

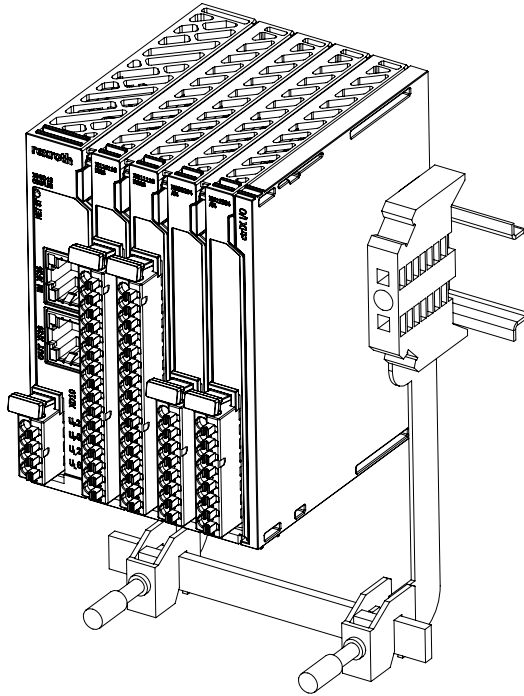

5.  Complete station



Connecting cable shield

The correct connection of shielded cables to the shield set ensures effective electromagnetic compatibility and safe operation. Only use suitable combinations of cable and shield clamp for the connection.

1.  Remove the outer cable jacket to such an extent that the exposed shielding fits completely under the shield connection terminal and allows full contact. Ensure not to damage the shielding.
2.  Insert the exposed shielding into the shield connection set.

3. → Fasten the shielding with a screwdriver. Ensure a tight fit to guarantee permanent contact. Start with minimal force and tighten the clamp slowly and evenly. Tighten the clamp only enough to ensure a secure hold and contact, and ensure that the inside of the cable is not damaged by the pressure.

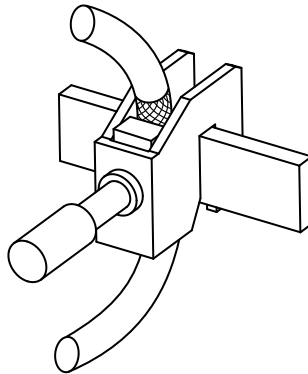

Dismounting

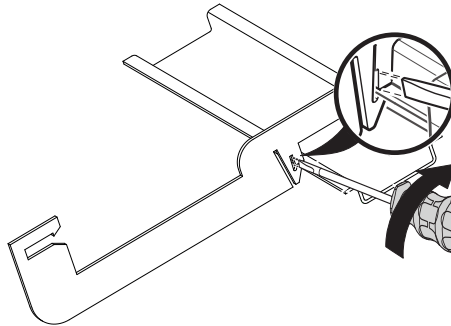

Fig. 27: Loosening shield set

Use a screwdriver with a 4 mm blade width for dismounting purposes.

- First remove the neighboring modules.
- Insert the screwdriver into the unlocking slot.
- Turn the screwdriver so that the snap hook is released from the support rail.
- Remove the shield rail holder.

13 Spare parts and accessories

13.1 RJ45 cable

Ordering code	Part number	Description
RKB0020	R911340676	Bus cable

13.2 End clamp

Ordering code	Part number	Description
SUP-M01-ENDHALTER	R911170685	2 pieces of snap-on end brackets for 35 mm NS 35/7.5 support rail; width: 9.5 mm

13.3 End cover

Ordering code	Part number	Description
XACC-2-ENDCOVR	R911412178	End cover

13.4 Shield connection

Part number	Description
R911173030	Shield connection set, 1 piece, includes 2 shield rail holders and 2 SK 5 shield clamps
R911173282	Shield clamp 5 mm diameter, 10 pieces
R911173286	Shield clamp 14 mm diameter, 10 pieces
R911173283	Busbar: 10 mm × 3 mm, 1 m long, 1 piece

14 Standards and approvals

14.1 General information

The products have been developed according to the German editions of the standards published at the time of product engineering.



Loss of conformity due to modifications at the device.

Declarations of conformity, certifications and corresponding markings apply only to the device upon delivery. After modifying the device, verify the conformity and certification.



For the currently valid declarations of conformity and certificates, go to: ➔ „DCTC-30455“

14.2 Standards used

Standard	Title
EN 60204-1:2019	Safety of machinery Electrical equipment of machines

Standard	Title
EN 61131-2	Programmable logic controllers Part 2: Equipment requirements and tests
DIN EN 61000-6-2	Electromagnetic compatibility (EMC) Part: 6-2: Generic standards – Noise immunity for industrial environments
DIN EN 61000-6-4	Electromagnetic compatibility (EMC) Part: 6-4: Generic standards – Emission standard for industrial environments
EN 60529:2014	Degrees of protection provided by enclosures (IP code)
EN 61010-1	Safety requirements for electrical equipment for measurement, control and laboratory use - Part 1: General requirements
EN 61010-2-201	Safety requirements for electrical equipment for measurement, control and laboratory use Part 2-201: Particular Requirements for Control Equipment
UL 61010-2-201	UL Standard for Safety Requirements for Electrical Equipment for Measurement, Control, and Laboratory Use Part 2-201: Particular Requirements for Control Equipment



For the current edition, if not specified, go to the EU declaration of conformity.

14.3 CE conformity



The ctrlX I/O modules fulfill the current EU directives according to the EU declaration of conformity.



For the latest published version of the EU declaration of conformity, go to the Bosch Rexroth Download Center: ➔ www.boschrexroth.com/MediaDirectory, search term ➔ „DCTC-30455“. For further versions (e.g. older products), please contact your Bosch Rexroth partner.

14.4 UKCA conformity



The ctrlX I/O modules fulfill the current UK directives according to the declaration of conformity.



For the UK declaration of conformity, go to the Bosch Rexroth Download Center: ➔ www.boschrexroth.com/MediaDirectory, search term ➔ "DCTC-30455".

14.5 UL/CSA-certified



For the certification under file no. E210730, go to ➔ <https://iq.ulprospector.com/en/profile?e=3996827>.

The certification was carried out according to:

- **UL 61010-2-201** (Industrial Control Equipment) and
- **CSA22.2 No. 61010-2-201** (CSA)

However, there can be modules with a limited or missing certification. Use the data sheet and labeling on the module to check whether approval has been granted. Follow the notes given in this application manual and in the relevant module data sheet.

15 Diagnostic and status displays

15.1 Diagnostic mechanisms

Different mechanisms are used for the diagnostics of the modules. Note that not all mechanisms are available for every module and that there may be minor module-specific deviations. Check the module-specific data sheet.

Mechanism	Diagnostics
EtherCAT state machine	EtherCAT system diagnostics
EtherCAT hardware watchdog	
Diagnostic objects in the CoE object directory 10F1(hex)	Extended diagnostics, e.g. peripheral errors Error settings
Diagnosis history object 10F3(hex)	20 diagnostic messages can be stored Diagnosis history
Module status LED	The module status LED at the top edge of the housing indicates the general module status
Channel status LED	Signals the channel status or the error states
NET status LED	Signals the EtherCAT slave state



Passive modules do not have a module status LED installed, as they are not active devices in the bus system. These include, for example, potential distribution modules, empty housing modules and passive boost modules.

15.2 Diagnosis history

The object 10F3(hex) is implemented as ring memory into the "Overwrite mode". The latest 20 diagnostic messages are stored. Older messages are deleted.

The following table shows the structure of the Diagnosis History object.

Index (hex)	Subindex	Object name	Data type	Rights	Meaning
10F3		Diagnosis history			Diagnostic statistics
	01	Maximum messages	UINT8	R	Maximum number of messages
	02	Newest message	UINT8	R	Latest message
	03	Newest acknowledged message	UINT8	R/W	Latest confirmed message. Writing "0" deletes the messages in the ring memory.
	04	New messages available	Boolean	R	New message available
	05	Flags	UINT16	R/W	Setting of the object response. Refer to ETG.1020
	06 - 26	Diagnosis message	String	R	Diagnostic message according to ETG.1020

Each diagnostic message itself is a data structure. For further details, refer to the official EtherCAT specification ETG.1020. The following table merely provides an overview on the key elements of the structure of a diagnostic message:

Parameter	Data type	Description of important information
Diag Code	UINT32	Diagnostic code of the message.
Flags	UINT16	Flags for this message Bit 3-0: Diagnostic type: 0 = Information, 1 = Warning, 2 = Error Bit 15-8: Number of parameters
Text ID	UINT16	Text ID of the corresponding diagnostic text in the ESI file: For details, refer to the data sheet of the respective module
Time Stamp	UINT64	Time stamp in ns
Flags Parameter 0...n	UINT16	Bit 15-12: Data type: 0 = number, 1 = byte array, 2 = ASCII string, 3 = Unicode string Bit 11-0: Type/length: For byte array or string: Length in bytes. For digits: 001(hex)=Boolean 002(hex)=INT8 003(hex)=INT16 004(hex)=INT32 005(hex)=UINT8 006(hex)=UINT16 007(hex)=UINT32 008(hex)=REAL32 011(hex)=REAL64 015(hex)=INT64 01B(hex)=UINT64
Parameter Data 0...n		Parameter data according to the previous definition in the "Flags".

The parameters are always transferred as a pair, first the flags and then the data. This is followed by the next parameter with flag and data, if available.

Example of a diagnostic message:

	Diagnostic code		Flags		Text ID	Time stamp	Parameter 1
Definition	Code	Code range	Flag type	Parameter number	Text ID in ESI	Time stamp (time since system start)	Channel
Sample data in hex:	20 23	01 E0	01	01	20 23	42 08 15 47 11 00 00 00	2 2

Corresponding entry in the ESI file:

```
<DiagMessage>
  <TextId><#x2320/TextId>
    <MessageText LcId="1033">Short circuit error at channel %d</
MessageText>
</DiagMessage>
```

By combining data in the diagnostic message and text from the ESI file, a complete message can be generated: #2320: Warning: Short-circuit error at channel 2.

```
#2320: Warning: Short circuit error at channel 2
```

15.2.1 Status codes in the Diagnosis History

The status codes are module-specific. Please refer to the data sheet of the respective module.

15.3 NET status LED

The NET status LED according to the EtherCAT specification (ETG.1300) displays the EtherCAT bus state at the module.

The operating state is displayed in green **GN**:

LED color green	Description
Off	Status INIT
Flickers	Status BOOT
Flashes	Status PRE-OP
Single flash	Status SAFE-OP
Lit	Status OP

The error state is displayed in red **RD**:

LED color red	Description
Off	No error
Flickers	Boot error
Flashes	Invalid configuration
Single flash	Local error (e.g. synchronization)
Double flash	Watchdog error
Lit	Communication error

15.4 Channel status LED

The availability and function of the channel status LED are module-specific. Thus, refer to the data sheet of the respective module.

16 Commissioning

16.1 IT security

Operating systems and machines requires the implementation of a comprehensive concept for state-of-the-art IT security. Bosch Rexroth products are part of this comprehensive concept. The properties of the Bosch Rexroth products have to be considered for a comprehensive IT Security concept. For the required properties, refer to the IT Security Guideline (↔ R911342562).

16.2 Device description files ESI

The device description files are provided with the ctrlX I/O Engineering installation.

For new versions of the ESI files or ESI files for the integration, go to ↗ <http://www.boschrexroth.com/electrics>, search term ↗ "ESI files".

16.3 Parameterizing modules

The parameters that can be configured in the CoE objects are usually not saved remanently by the modules. To automatically load the settings required upon each bus start, set the values in the start parameters of the Engineering.

16.4 Writing "Configured Station Alias"

The "Configured Station Alias" allows the fixed address assignment for the module within the EtherCAT topology. The address is saved in the EEPROM of the module.

Bring the system into the safe state to write the "Configured Station Alias" before starting the programming. Apart from the "Configured Station Alias", no other values of the EEPROM content may be changed. After writing, the respective module has to be restarted via a voltage cycle of the complete station to use the value.

17 License information

17.1 EtherCAT®



The ctrlX I/O modules use EtherCAT® technology. "EtherCAT®" is a registered trademark and patented technology licensed by the Beckhoff Automation GmbH, Germany. EtherCAT is an open, internationally standardized standard and developed further by the "EtherCAT Technology Group" (ETG).

18 Disposal

Dispose the products according to the respective valid national standards.

19 Service and support

Our worldwide service network provides an optimized and efficient support. Our experts provide you with advice and assistance. You can contact us **24/7**.

Service Germany

Our technology-oriented Competence Center in Lohr, Germany, is responsible for all your service-related queries for electric drive and controls.

Contact the **Service Hotline** and **Service Helpdesk** under:

Phone: **+49 9352 40 5060**

Fax: **+49 9352 18 4941**

Email: [↪ service.svc@boschrexroth.de](mailto:service.svc@boschrexroth.de)

Internet: [↪ http://www.boschrexroth.com](http://www.boschrexroth.com)

Additional information on service, repair (e.g. delivery addresses) and training can be found on our internet sites.

Service worldwide

Outside Germany, please contact your local service office first. For hotline numbers, refer to the sales office addresses on the internet.

Preparing information

To be able to help you more quickly and efficiently, please have the following information ready:

- Detailed description of malfunction and circumstances
- Type plate specifications of the affected products, in particular type codes and serial numbers
- Your contact data (phone and fax number as well as your e-mail address)

Index

A

Accessories	44
Ambient conditions	27
Article name	15
Autocrossover	37

B

Bending radii	37
Busbar	44

C

Cable	
Permitted	35
Cables	
Permitted	34
CE conformity	45
Channel status LED	49
Colors of pushers	25
Commissioning	49
Concept of the voltage supply	16
Configured Station Alias	49
Connecting cable shield	42
Connection	
electrical	33
Control ctrlX CORE	11
Cover	44
ctrlX CORE control	11
ctrlX I/O station	
Design	9

D

Declaration of conformity	
EU	45
UKCA	45
Design	20
Peripheral plug	25
Design of a ctrlX station	9
Device description files	49
Device overview	11
Diagnosis history	47
Diagnostic displays	46
Diagnostic mechanisms	46
Dimensions	22, 26
Dismounting	33
Shield set	43

Disposal	50
Documentation	
Revision history	6
Scope of validity	6
Documents, related	6

E

Electric installation	33
Electrical isolation	17
Electrical safety	8
Electromagnetic compatibility	44
EMC	44
End clamp	44
End clamps	29
End cover	44
Endcover	29
ESI files	49
EtherCAT bus coupler	13, 20
Dimensions	23
EtherCAT network	37
EU declaration of conformity	45

F

Functional earth	38
------------------------	----

G

GND-FE binding	20
Grounding	38

H

Helpdesk	51
Hotline	51
Housing dimensions	22

I

I/O module	21
Identification of the product	7
Input and output modules	14
Dimensions	24
Installation	29
Installation notes	29
Installation, electric	33
Installing	
Lines	35
Installing Ethernet cable	37
Intended use	8
IT security	49

L	
LED	
Channel status	49
License information	49
Line installation	35
Lines	
Permitted	34, 35
Logic voltage supply	36
M	
Modular I/O system	8
Module mounting	28, 30
Module types	15
Modules, passive	30
Mounting	
Basics	28
I/O module	30
Location	29
Notes	29
Shield sets	40
Mounting rail	29
Mounting rail holder	21
Multi-wire technique	19
O	
Overheating	28
P	
Parameterizing modules	49
Passive modules, maximum number	30
Peripheral plug	25
Dimensions	26
Position	31
Remove	32
Peripheral voltage supply	37
Plug	
Position	31
Remove	32
Tools	34
Potential equalization	38
Product description	10
Product group ctrlX	8
Product identification	7
Pusher colors	25
R	
Revision history	6
RJ45 cable	44
S	
Safety instructions	7
Scope of validity	6
Security	49
Segmentation	19
Service hotline	51
Shield connection	44
Shield set	39, 44
Shield support	44
Shielding	37, 38
Spare parts	44
Standards	44
EMC	44
Start parameters	49
Status codes	48
Status displays	46
Storing	27
Support	51
System modules XI8	15
T	
Tools	34
Transporting	26
U	
UKCA conformity	45
UL/CSA-certified	45
Uninstalling	
Lines	35
Unpacking	27
Use, intended	8
User qualification	7
V	
Variant overview	15
Ventilation distances	29
Voltage boost	18
Voltage concept	16
Voltage infeed, dimensioning	36
Voltage supply	36
W	
Wire end ferrules	34
Orientation	36

Wires
 Permitted 34

Bosch Rexroth AG
Bgm.-Dr.-Nebel-Str. 2
97816 Lohr a.Main
Germany
Tel. +49 9352 18 0
Fax +49 9352 18 8400
www.boschrexroth.com/electrics



R911423458 02