

IndraControl S20-AI6-AO2-SSI2

6 Analog Inputs, 2 Analog Outputs, 2 SSI Inputs

Data Sheet

R911342258

Edition 06

1 Description

Product identification and type plate

2 Ordering data

3 Technical data

4 Ambient conditions

5 Standards

Standards used

CE marking – Declaration of conformity

6 Internal schematic diagram

7 Clamping point assignment

8 Connection data

9 Connection examples

10 Installation notes

11 Local status displays and diagnostic displays

12 Process data

13 Parameters, diagnostics and information (PDI)

14 Device description files

- 1 The module is designed to be used in an IndraControl S20
- 1 station. The module detects analog input signals and out-
- 1 puts analog signals. The SSI interfaces detect data of abso-
- 2 lute value encoders with a resolution between 8 to 31 bits
- 2 and transmission rates up to 4 MHz.
- 5 The module is designed for two hydraulic axes. The follow-
- 6 ing inputs and outputs are available for each hydraulic axis:
- 6 ▶ Three analog inputs
- 6 ▶ One digital SSI interface for absolute value encoders
- 6 ▶ One analog output

- 7
- 7  This data sheet is only valid if used with the ap-
- 7 plication descriptions "IndraControl S20 2-Axis
- 8 Module 6 Analog Inputs, 2 Analog outputs, 2
- 9 SSI inputs", part no. [R911342260](#) and
- 10 "IndraControl S20: System and Installation",
- 10 part no. [R911335988](#).
- 10

1 Description



Front view

Product identification and type plate

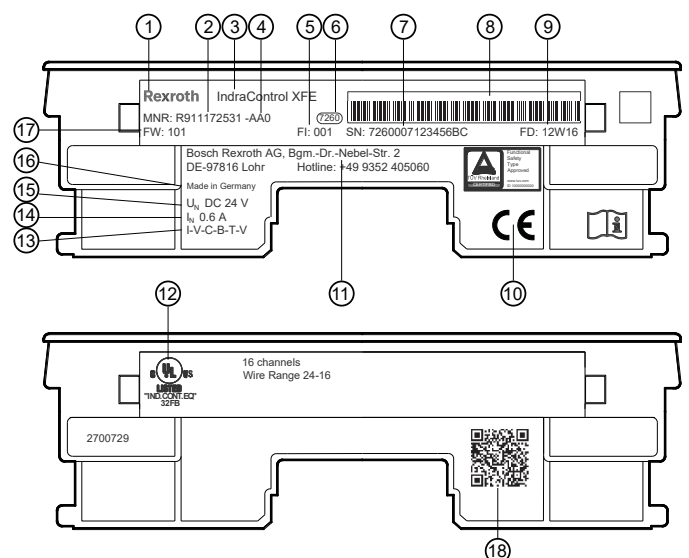

- 1 Word mark
- 2 Part number
- 3 Device name
- 4 State of revision
- 5 Functional index

6	Plant number
7	Serial number
8	Serial number as barcode
9	Date of manufacture (yyWwww)
10	CE conformity marking
11	Company address
12	Underwriters Laboratories Inc. mark
13	Check digit
14	Nominal current
15	Nominal voltage
16	Manufacturing country
17	Software release
18	QR code

Exemplary type plate

2 Ordering data

Module	Type	Part no.
IndraControl S20 Function Module 6 analog inputs (single-ended) 2 analog outputs 2 SSI channels	S20-AI6-AO2-SSI2	R911173120
Accessories		Part no.
Rexroth IndraControl S20 Bus Base Module	S20-BS	R911173203
Shield connection set ^①	S20-SHIELD-SET	R911173030
Shield terminal with shield support on bus bars: Diameter of 5 mm Diameter of 14 mm Bus bar: 10 mm × 3 mm, 1 m long	S20-SHIELD-SK5 S20-SHIELD-SK14 S20-SHIELD-NLS	R911173282 R911173286 R911173283
Documentation		Part no.
Application Description IndraControl S20 2-Axis Module 6 Analog Inputs, 2 Analog Outputs, 2 SSI Inputs		R911342260
Application Description IndraControl S20: System and Installation		R911335988

① The shield connection set includes two shield bus clamps and two SK5 shield terminals

3 Technical data

Dimensions and weight	
Width	53.6 mm
Height	126.1 mm
Depth	54 mm The depth applies when using one mounting rail TH 35-7,5 (acc. to EN 60715)
Weight	205 g

Peripheral supply	
Logic voltage U_B	5 V DC (via bus base module)
Current consumption from U_{Bus}	Typically 250 mA, maximum 300 mA
Power consumption from U_{BUS}	Typically 1.25 W, maximum 1.5 W
Voltage supply and current consumption	
The following specifications include the EN 61131-2 values	
Infeed of the digital input modules UI	24 V DC PELV/SELV (safety extra-low voltage)
Maximum voltage range al- lowed	18 V DC to 31.2 V DC (incl. all tolerances and ripple)
Current consumption from UI	800 mA max. 100 mA intrinsic current consumption + 2 × 100 mA analog sensor and actuator supply + 2 × 250 mA SSI encoder supply
Power consumption from UI (only intrinsic current con- sumption)	2.4 W max.
Reverse voltage protection of the supply voltage	Via diode
Fuse protection	Internal protective fuse, 4 A, slow
Transient protection	Yes, via suppressor diodes
Voltage dips at current supply interfaces	Up to 1 ms without impairment
Electrical isolation and isolation of the voltage ranges	
5 V supply (logic) to 24 V sup- ply (periphery)	845 V AC, 50 Hz, 1 min
5 V supply (logic) to the func- tional earth	845 V AC, 50 Hz, 1 min
24 V supply (periphery) to the functional earth	845 V AC, 50 Hz, 1 min
Note: Up to the state of revision "AF1", there was a direct connection be- tween the 24 V GND and the functional earth.	

NOTICE

Electronic damage due to polarity reversal or due to a nominal current that is too low

The power supply unit has to be able to deliver the quadruple nominal current of the protective fuse to ensure that the fuse reliably triggers in case of an error.

Analog sensor supply and actuator supply (from the input voltage UI)

Current per axis	-25 °C - +40 °C: 2 × 100 mA +40 °C - +60 °C: 2 × 90 mA
------------------	---

Short-circuit protection	Electronically, per axis
Analog inputs in current mode or voltage mode with single-channel diagnostics, can be switched	
Number	6 analog single-ended inputs
Measuring value resolution	16 bits (15 bits + sign)
Update period for process data	Maximum of 38 μ s (256-times software average value generation, 4-times oversampling)
Transient protection	Yes, via suppressor diodes
Input filter	23 kHz (-3 dB), average value generation via software
Connection method	2- to 3-wire technique, shielded cable, twisted in pairs
Connection method	Push-in technology
Maximum voltage range allowed between analog voltage inputs (AI1 to AI6) and analog ground (AGND)	± 30 V DC
Voltage mode	
Input voltage range	100 mV to 10 V, 0 to 10 V, ± 10 V
Input resistance	> 260 k Ω
Wire break detection	0 V to 99 mV (only for 100 mV up to 10 V)
Current mode	
Input range	± 10 mA, ± 20 mA, 0 to 20 mA, 4 to 20 mA
Input resistance	240 Ω
Wire break detection	0 mA to 3.9 mA (only for 4 mA to 20 mA)
Analog outputs in current mode or voltage mode, can be switched	
Number	2 analog outputs
Measuring value resolution	16 bits (15 bits + sign)
Connection method	2-wire technique, shielded cable, twisted in pairs
Wire break detection	0 mA to 3.9 mA (only for 4 mA to 20 mA)
Output voltage range	0 to 10 V, ± 10 V
Output current range	± 10 mA, ± 20 mA, 0 to 20 mA, 4 to 20 mA
Output load	
Voltage output	RLmin = 2 k Ω
Current output	RL = 0 Ω to 500 Ω
Transient protection	Yes, via suppressor diodes
Short-circuit protection	Yes, self-healing; is controlled internally
SSI interface for absolute value encoder	
Number	2
Encoder signal	Cycle, inverted (acc. to RS-422 protocol) Data, inverted (acc. to RS-422 protocol)
Connection method	Shielded cable, twisted in pairs
Resolution	8 to 31 bits
Coding	Gray code or binary code
Parity	None, even, uneven

Cycle rate setting	67.5 kHz, 100 kHz, 125 kHz, 200 kHz, 250 kHz, 300 kHz, 400 kHz, 500 kHz, 600 kHz, 700 kHz, 800 kHz, 900 kHz, 1 MHz, 2 MHz, 4 MHz
Electric strength	± 60 V
Short-circuit protection	Yes, internal limitation of the short circuit current
Cable length	30 m max. Note: For the supply lines for SSI channels, the shield is connected to both sides
SSI encoder supply (from the input voltage UI)	
Current per axis	-25 $^{\circ}$ C - +40 $^{\circ}$ C: 2 \times 250 mA +40 $^{\circ}$ C - +60 $^{\circ}$ C: 2 \times 200 mA
Short-circuit protection	Electronically, per axis (with single-channel diagnostics)

Tolerances at T_U = 25 $^{\circ}$ C

Measuring range AI	Absolute Typical	Absolute Maximum	Relative Typical	Relative Maximum
0 V to 10 V	± 20 mV	± 30 mV	0.2 %	± 0.3 %
100 mV to 10 V				
± 10 V				
± 10 mA	± 40 μ A	± 60 μ A	0.2 %	± 0.3 %
0 mA to 20 mA				
4 mA to 20 mA				
± 20 mA				
Output range AO	Absolute Typical	Absolute Maximum	Relative Typical	Relative Maximum
0 V to 10 V	± 10 mV	± 15 mV	0.1 %	± 0.2 %
± 10 V				
± 10 mA	± 20 μ A	± 40 μ A	0.1 %	± 0.2 %
0 mA to 20 mA				
4 mA to 20 mA				
± 20 mA				



The specifications include offset errors, gain errors and linearity errors. All tolerance specifications in percent refer to the respective end value of the measuring range. If not specified differently, the rated operation (rated voltage $U_I = 24\text{ V DC}$, no average value generation, horizontal installation position on the mounting rail) is used.

Observe the additional values for temperature drift and tolerances due to electromagnetic disturbances. The maximum tolerance specifications represent the worst case measuring uncertainty. The measuring uncertainty includes the virtually maximum possible tolerance limits in the measuring range sections.

Tolerances and temperature behavior at $T_U = -25\text{ °C}$ to $+60\text{ °C}$

Measuring range AI	Drift typical	Maximum drift
0 V to 10 V	$\pm 40\text{ ppm/K}$	$\pm 55\text{ ppm/K}$
100 mV to 10 V $\pm 10\text{ V}$		
$\pm 10\text{ mA}$	$\pm 100\text{ ppm/K}$	$\pm 170\text{ ppm/K}$
0 mA to 20 mA 4 mA to 20 mA $\pm 20\text{ mA}$		
Output range	Drift typical	Maximum drift
0 V to 10 V $\pm 10\text{ V}$	$\pm 10\text{ ppm/K}$	$\pm 25\text{ ppm/K}$
$\pm 10\text{ mA}$	$\pm 20\text{ ppm/K}$	$\pm 30\text{ ppm/K}$
0 mA to 20 mA 4 mA to 20 mA $\pm 20\text{ mA}$		



The drift specifications always refer to the respective end value of the measuring range. The specifications refer to the rated operation in horizontal installation position on the mounting rail.

Formula to calculate the tolerance under temperature influence

Typical temperature drift

$$\text{Drift}_{\text{typ}} = \Delta\vartheta \times T_{\text{Ktyp}} \times \text{MEW}$$

This includes:

$$\text{Drift}_{\text{typ}} = \text{Typical temperature drift}$$

$\Delta\vartheta$ = Temperature difference between the ambient temperature of the module T_U and $+25\text{ °C}$

T_{Ktyp} = Typical temperature coefficient in ppm/K

MEW = End value of the measuring range (e.g. 10 V voltage mode)

Maximum temperature drift

$$\text{Drift}_{\text{max}} = \Delta\vartheta \times T_{\text{Kmax}} \times \text{MEW}$$

This includes:

$\text{Drift}_{\text{max}}$ = Maximum temperature drift

$\Delta\vartheta$ = Temperature difference between the ambient temperature of the module T_U and $+25\text{ °C}$

T_{Kmax} = Maximum temperature coefficient in ppm/K

MEW = End value of the measuring range

Example:

Voltage mode 10 V

Ambient temperature $T_U = +40\text{ °C}$

Temperature coefficient $T_{\text{Ktyp}} = 40\text{ ppm/K}$

Temperature coefficient $T_{\text{Ktyp}} = 55\text{ ppm/K}$

$$\text{Drift}_{\text{typ}} = \Delta\vartheta \times T_{\text{Ktyp}} \times \text{MEW} = 10\text{ V} \times \pm 40\text{ ppm/K} \times (40\text{ °C} - 25\text{ °C}) = 10\text{ V} \times \pm 0.00004\text{ 1/K} \times 15\text{ °C} = \pm 6.0\text{ mV}$$

$$\text{Drift}_{\text{max}} = \Delta\vartheta \times T_{\text{Kmax}} \times \text{MEW} = 10\text{ V} \times \pm 55\text{ ppm/K} \times (40\text{ °C} - 25\text{ °C}) = 10\text{ V} \times \pm 0.000055\text{ 1/K} \times 15\text{ °C} = \pm 8.25\text{ mV}$$

Tolerances due to electromagnetic disturbances

		Analog input		Analog output	
		Current	Voltage	Current	Voltage
Electromagnetic fields	EN 61000-4-3 IEC 61000-4-3	$< \pm 1\%$	$< \pm 2\%$	$< \pm 0.5\%$	$< \pm 0.5\%$
Fast transients (burst)	EN 61000-4-4 IEC 61000-4-4	$< \pm 1\%$	$< \pm 2\%$	-	-
Conducted disturbances	EN 61000-4-6 IEC 61000-4-6	-	-	-	-



The mentioned values refer to the rated operation in case of direct interference of the components without additional shielding measures as in case of a steel cabinet for example. The above mentioned tolerances can be reduced by further shielding measures for the I/O module (by using a shielded control box or a control cabinet for example). Activating the average value generation in the IndraWorks Engineering software allows to improve the tolerances for analog inputs.

Signal rise times: Voltage output from 0 V to 10 V (typ. specifications)

	10 % to 90 %	0 % to > 99 %
Ohmic load $R_L = 2 \text{ k}\Omega$	11 μs	20 μs
Ohmic/capacitive load $R_L = 2 \text{ k}\Omega/C_L = 10 \text{ nF}$	9 μs	17 μs
Ohmic/capacitive load $R_L = 2 \text{ k}\Omega/C_L = 220 \text{ nF}$	160 μs	190 μs
Ohmic/inductive load $R_L = 2 \text{ k}\Omega/L_L = 3.3 \text{ mH}$	12 μs	22 μs

Signal rise times: Current output from 0 mA to 20 mA (typical specifications)

	10 % to 90 %	0 % to > 99 %
Ohmic load $R_L = 500 \text{ k}\Omega$	3 μs	4 μs
Ohmic/capacitive load $R_L = 500 \Omega/C_L = 10 \text{ nF}$	13 μs	20 μs
Ohmic/capacitive load $R_L = 500 \Omega/C_L = 220 \text{ nF}$	330 μs	600 μs
Ohmic/inductive load $R_L = 500 \Omega/L_L = 3.3 \text{ mH}$	2 μs	4 μs

Signal rise times: Current output from 4 mA to 20 mA (typical specifications)

	10 % to 90 %	0 % to > 99 %
Ohmic load $R_L = 500 \Omega$	3 μs	4 μs
Ohmic/capacitive load $R_L = 500 \Omega/C_L = 10 \text{ nF}$	11 μs	20 μs
Ohmic/capacitive load $R_L = 500 \Omega/C_L = 220 \text{ nF}$	280 μs	470 μs
Ohmic/inductive load $R_L = 500 \Omega/L_L = 3.3 \text{ mH}$	2 μs	5 μs

4 Ambient conditions

Ambient conditions

Ambient temperature (Operation)	Up to 2000 m: -25 °C to +60 °C 2000 m to 3000 m: -25 °C to +55 °C
Ambient temperature (Storage, transport)	-40 °C to 85 °C
Permitted air humidity (Operation, storage and transport)	5 % to 95 % (acc. to DIN EN 61131-2) No condensation
Operating altitude	Up to 3,000 m above sea level
Degree of protection	IP20 acc. to DIN EN 60 529
Protection class	III, DIN EN 61010-2-201
Overvoltage category	2
Contamination level	2, no condensation allowed

Mechanical tests

Vibration resistance acc. to DIN EN 60068-2-6	Oscillations, sinusoidal in all three axes 5 Hz - 9 Hz with 3.5 mm amplitude 9 Hz - 150 Hz with 5 g peak acceleration
Shock test acc. to DIN EN 60068-2-27	Shock stress: Shock resistance in all three axes 11 ms semi-sinusoidal 30 g
Broadband noise acc. to DIN EN 60068-2-64	5-20-150 Hz with 0.572 g, 5 h per axis

Electrostatic discharge (ESD) DIN EN 61000-4-2	Criterion B, 6 kV, contact discharge, 8 kV air discharge
--	--

NOTICE

Defective product due to gases jeopardizing functions

Due to the risk of corrosion, avoid sulphurous gases (e.g. sulphur dioxide (SO₂) and hydrogen sulphide (H₂S)). The product is not resistant against these gases.

NOTICE

Failure of the product due to contaminated air

- ▶ The ambient air must not contain acids, alkaline solutions, corrosive agents, salts, metal vapors and other electrically conductive contaminants in high concentrations
- ▶ The devices to be installed into the housings and installation compartments must at least comply with the degree of protection IP 54 according to EN 60529.

- ▶ The device shall be provided in a suitable fire enclosure in the end-use application.

NOTICE

Component failure due to overheating

To avoid overheating and a trouble-free operation of the control, ambient air has to circulate. Also refer to the chapter "Installation notes".



This is a product that corresponds to the limit values of the emitted interference of class A (industrial environments). This is a product that does *not* correspond to the limit values of the emitted interference of class B (residential area and small enterprises)
When using the product in residential areas or small enterprises, the operator has to take actions to prevent radio interferences (also refer to EN 55022).

5 Standards

This product has been developed according to the current German edition of the standards at the time of product development.

Standards used

Standard	Meaning	Output
DIN EN 60204-1	Electrical equipment of machines	2007
DIN EN 61131-2	Programmable logic controllers Equipment and test requirements	2008
DIN EN 60529	Degrees of protection (including housings and installation compartments)	2014
DIN EN 61010-2-201	Safety requirements for electrical equipment for measurement, control and laboratory use	2014
UL 61010-2-201	Safety requirements for electrical equipment for measurement, control and laboratory use	2014

CE marking – Declaration of conformity



The electronic product described in the present data sheet complies with the requirements and the target of the following EU directive and with the following harmonized European standards:

EMC directive 2014/30/EU

The electronic product described in the present data sheet is intended for use in industrial environments and comply with the following requirements:

Standard	Meaning	Edition
DIN EN 61000-6-4	Electromagnetic compatibility (EMC) Part 6-4: Generic standards – Emission standard for industrial environments	September 2011
DIN EN 61000-6-2	Electromagnetic compatibility (EMC) Part 6-2: Generic standards – Immunity for industrial environments	March 2006



Loss of CE conformity due to modifications at the device

CE marking applies only to the device upon delivery. After modifying the device, verify the CE conformity.

6 Internal schematic diagram

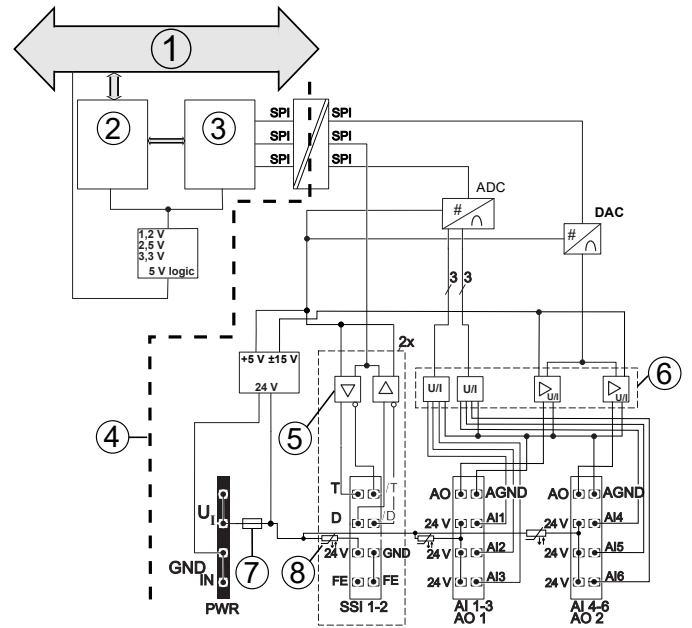

- ① S20 local bus with supply voltage
- ② Local bus FPGA
- ③ Application FPGA
- ④ Electrical isolation
- ⑤ Driver I/O SSI channel
- ⑥ Current switching, voltage switching
- ⑦ Protective fuse
- ⑧ PolyFuse (PTC)

Internal wiring of the clamping points

7 Clamping point assignment

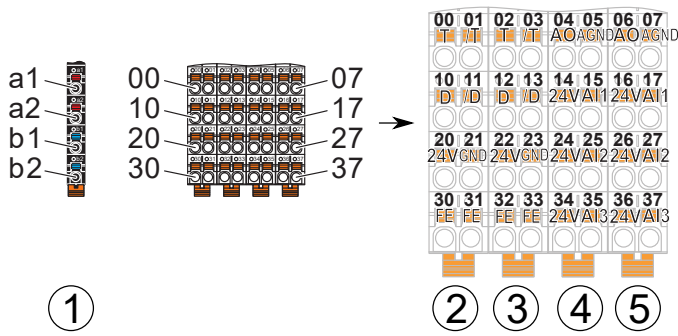

- ① Voltage supply
- ② SSI encoder input, axis 1
- ③ SSI encoder input, axis 2
- ④ Analog inputs and outputs, axis 1
- ⑤ Analog inputs and outputs, axis 2

Clamping point	Color	Assignment	Description
----------------	-------	------------	-------------

Feeding the supply voltage

a1, a2	Red	24 V DC (UI)	Feeding module supply, encoder supply and analog supply (internally bridged)
b1, b2	Blue	GND	Reference potential against U_i (internally bridged)

SSI absolute value encoder

Axis 1, axis 2

00	02	Orange T	Cycle
01	03	Orange /T	Inverted cycle
10	12	Orange D	Data
11	13	Orange /D	Data inverted
20	22	Orange 24 V DC	SSI encoder supply
21	23	Orange GND	Reference potential against the SSI encoder supply
30	31	Orange FE	Functional earth
32	33	Orange FE	Functional earth

Analog inputs and outputs

Axis 1, axis 2

04	06	Orange AO1/AO2	Analog output (U/I)
05	07	Orange AGND	Analog reference potential
14	16	Orange 24 V DC	Analog sensor and actuator supply
15	17	Orange AI1/AI4	Analog input (U/I)
24	26	Orange 24 V DC	Analog sensor and actuator supply
25	27	Orange AI2/AI5	Analog input (U/I)
34	36	Orange 24 V DC	Analog sensor and actuator supply
35	37	Orange AI3/AI6	Analog input (U/I)

8 Connection data

General data	
Plug name	S20 plug
Connection method	Spring-cage connection in direct plug-in technology
Conductor cross-section either rigid or flexible	0.2 mm ² to 1.5 mm ²
Conductor cross-section (AWG)	24 to 16

Interface of the S20 local bus

Connection method	Bus base module
Transmission rate	100 MBit/s

9 Connection examples

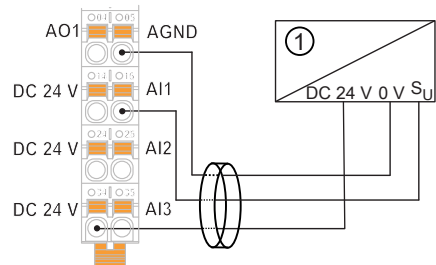

- ① Sensor
Connection example: Load cell, three-wire technique, 0 to 10 V (S_U = Voltage signal) at axis 1. The shield has to be always connected to the shield set. The shield set has to be connected to the top-hat rail

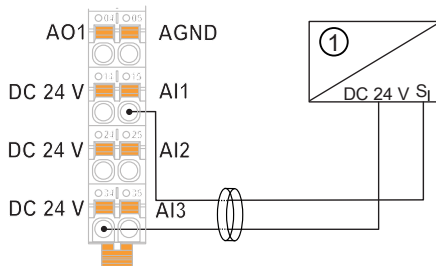

- ① Sensor
Connection example: Load cell, two-wire technique, 4 to 20 mA (S_I = Current signal) at axis 1. The shield has to be always connected to the shield set. The shield set has to be connected to the top-hat rail

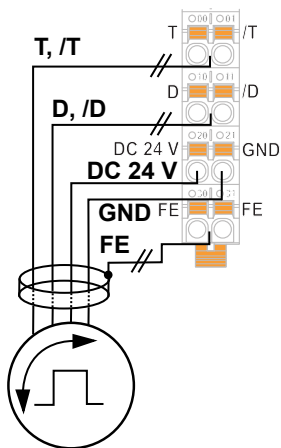

Connection example of the SSI encoder

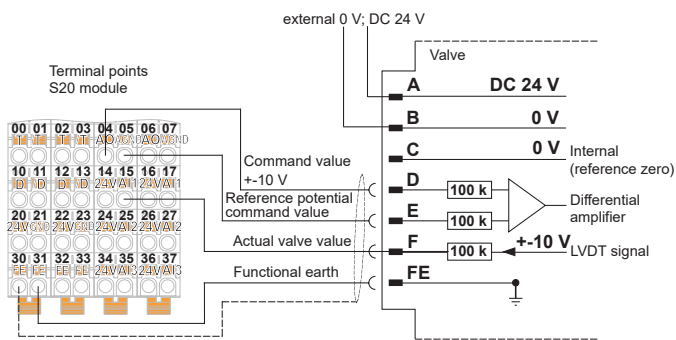

Connection example: Valve in two-wire technique, 0 to 10 V at axis 1. The shield has to be always connected to the shield set. The shield set has to be connected to the top-hat rail

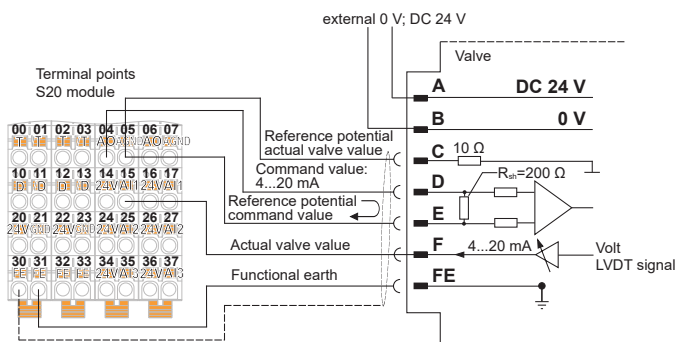

Connection example: Valve in two-wire technique, 4 to 20 mA at axis 1. The shield has to be always connected to the shield set. The shield set has to be connected to the top-hat rail

10 Installation notes

- ▶ Always connect the analog sensors and actuators as well as the SSI encoders with shielded cables twisted in

pairs. With unshielded cables, tolerance limits can be easily exceeded in environments prone to interferences

- ▶ Generally, the following applies to the potential equalization in automation systems:
 - Shielded analog I/O cables may only be connected directly to the ground potential at one point. This impedes potential equalization currents via the analog cable
 - For SSI encoders, the shielded cable has to be connected to both sides. For unshielded cables or incorrect laying of the shielding concept, incorrect analyses can be caused
 - Integrate the shielding concept for analog I/O cables and the system concept if necessary. It is reasonable to use a central functional earth shielding connection at the control cabinet input
 - Bosch Rexroth recommends the IndraControl S20 shielding connection set "S20-SHIELD-SET" to connect the shielding, part no. R911173030
 - For more information on the shielding concept, refer to the application description of the system IndraControl S20, part number [R911335988](#)
- ▶ Do not wire cables parallel to motor cables or other strong interference sources to avoid coupling of interferences
- ▶ The LED displays may not be hidden
- ▶ Use strain reliefs for all cables
- ▶ Keep the maximum distance possible from interference sources
- ▶ Provide minimum distances for sufficient cooling. Refer to the operating instructions of the "IndraControl XM21, XM22 Controls", part no. [R911340667](#). In case of a multiple-line design, the supply air has to be measured under each line and its limit value has to be observed. For information on ambient temperatures, refer to "[4 Ambient conditions](#)" on page 5
- ▶ Additionally, provide sufficient distance for mounting, demounting, plugs and cables
- ▶ The installation position is the wall mounting on a horizontal mounting rail
- ▶ Use only cables approved for temperatures of at least +60°C. In case of ambient temperatures above +55 C, use cables approved for temperatures of at least +75°C
- ▶ For more information on mounting, demounting and connecting lines, refer to the application description "IndraControl S20: System and Installation", part no. [R911335988](#)



Explaining the signal alert symbol on the device



The symbol with the exclamation marks in the triangle on the device indicates important notes present in the operating instruction/data sheet that must be observed to determine the type of potential **DANGER** and to identify the actions required to avoid that **DANGER**. Furthermore, if your health is at risk, e.g. due to an electric shock.

11 Local status displays and diagnostic displays

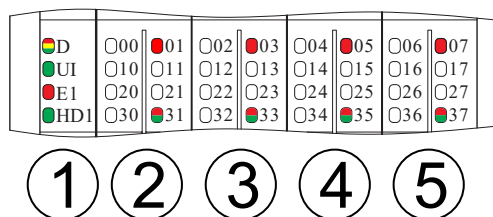

- ① Voltage supply
- ② SSI encoder input, axis 1
- ③ SSI encoder input, axis 2
- ④ Analog inputs and outputs, axis 1
- ⑤ Analog inputs and outputs, axis 2

Local status displays and diagnostic displays

Name	LED color	Meaning	LED state	Description
D	Red/yellow/ green	Diagnostics of the local bus communication		
		Power down	Off	Devices in (power) reset
		Not connected, reset	Flashing red	Device is operating, but no connection to the device in front
		Reset	Red on	Application reset Device is operating, but no connection yet to the device in front. Application in reset
		Ready	Yellow on	Device is operating and there is a connection to the device in front. The device has not yet detected any valid cycle after "Power on"
		Connected	Flashing yellow	Valid data cycles are detected. However, the device is not (yet) part of the current configuration
		Device application not ready	Green/yellow alternating	Valid data cycles are detected. The master application sets the user data to valid. However, the slave application did not set the user data to valid or it cannot output the user data (e.g. periphery error)
		Run	Green on	Valid data cycles are detected. All data is valid
UI	Green	U _{Input}	On	Feeding encoder supply and analog supply present
			Off	Feeding encoder supply and analog supply is not present
E1	Red	Group error	On	Supply U _i not present or malfunction at one of the internal power supply units. Module reports a detailed diagnostics in the standard object, diagnostic state (0018hex: DiagState)
			Off	There is no malfunction
HD1	Green	Voltage monitoring of the local bus	On	Voltage supply present via local bus
			Off	Voltage supply not present via local bus
Channels SSI1 and SSI2				
01 and 03	Red	SSI error	On	SSI error occurred
			Off	No error occurred

Name	LED color	Meaning	LED state	Description
31 and 33	Green/red	Status of the 24 V encoder supply of the respective SSI channels	Green on	Encoder supply ok
			Red on	Short-circuit or overload
			Off	Encoder supply is not present
Analog outputs (AO1 and AO2)				
05 and 07	Red	Error at the analog output	On	Malfunction at the output
			Off	No malfunction at the output
Analog inputs (24 V sensor supply or actuator supply)				
35 and 37	Green/red	Status of the analog sensor supply or actuator supply	Green on	Analog sensor or actuator supply available
			Red on	Short-circuit or overload of the sensor supply or actuator supply
			Off	Sensor supply or actuator supply not present



For more information on the local diagnostic and status displays, refer to the application description of the system IndraControl S20, part number [R911335988](#).

12 Process data

For information on the assignment of process data words, refer to the application description "IndraControl S20 2-Axis Module 6 Analog Inputs, 2 Analog outputs, 2 SSI inputs", part no. [R911342260](#).

13 Parameters, diagnostics and information (PDI)

Parameter data and diagnostic data as well as other information is transferred via the PDI channel. In IndraWorks, these parameters are displayed in the configurator.



For information on the PDI and on all objects created on the module, refer to the application description "IndraControl S20 2-Axis Module 6 Analog Inputs, 2 Analog outputs, 2 SSI inputs", part no. [R911342260](#).



Upon delivery, the module is provided with a default configuration to commission the module without parameterization.

14 Device description files

The device is described in device description files. To download the device description files, go to www.boschrexroth.com ► **Products** ► **Electric Drives and Controls** ► **I/O** ► **IndraControl S20 (IP20)** in the download range of the field bus coupler or the control used.



Copyright

© Bosch Rexroth AG 2025
All rights reserved, also regarding any disposal, exploitation, reproduction, editing, distribution, as well as in the event of applications for industrial property rights.