

S20 temperature module 4 inputs

R911342776
Edition 02

Data sheet S20-AI-4-RTD

4 analog inputs
Connection of resistive temperature shunts
2-, 3-, 4-conductor technology

10 / 2022



1 Description

The module is designed for use within an S20 station. It is used to acquire signals from resistive temperature sensors.

The module supports all common platinum and nickel sensors in accordance with DIN EN 60751 and SAMA.

Cu10, Cu50, Cu53 sensors as well as various KTY8x sensor types are also supported.

Features

- 4 analog input channels for connecting resistance temperature detectors (RTDs)
- 500 Ω and 5 k Ω linear inputs
- Connection of sensors in 2-, 3-, and 4-conductor technology
- Integrated, digital sensor linearization
- Standardized measured value representation directly in $^{\circ}\text{C}$, $^{\circ}\text{F}$ or Ω
- Measured value display in 16-bit format or floating point format
- Programmable filters
- Short-circuit protected inputs
- Temperature stability

- Very high level of noise immunity
- Low noise emission
- Installation monitoring by means of "Channel scout" function
- Device rating plate stored



This data sheet is only valid in association with the application description for the S20 system, material number R911335988.



Make sure you always use the latest documentation.

It can be downloaded under www.boschrexroth.com/electrics.

2 Table of contents

1	Description	1
2	Table of contents	2
3	Ordering data	3
4	Technical data	3
5	Additional technical data.....	7
6	Temperature and resistance measuring ranges	8
7	Tolerance data.....	9
8	Temperature and drift response	12
9	Internal circuit diagram	14
10	For your safety.....	14
11	Terminal point assignment.....	15
12	Connection examples	16
13	Connection notes	16
14	Local diagnostic and status indicators	17
15	Diagnostic behavior in the event of an error.....	18
16	Process data.....	19
17	Significant values.....	20
18	Parameter, diagnostics and information (PDI)	20
19	Standard objects	21
20	Application objects	24
21	Parameterization example	29
22	Device descriptions	29
23	Measuring errors caused by connecting cables for sensors with 2-conductor connection	30
24	Calculation examples	31

3 Ordering data

Description	Type	MNR	Pcs./Pkt.
S20 temperature module 4 inputs for temperature shunts	S20-AI-4-RTD	R911173341	1
Accessories	Type	MNR	Pcs./Pkt.
S20 bus base module, narrow	S20-BS-S	R911173203	5
S20 Shield set	S20-SHIELD-SET	R911173030	1
Shield connection clamps, for shield on busbars, for conductor diameters ≤ 5 mm, contact resistance < 1 m Ω	S20-SHIELD-SK5	R911173282	10
Shield connection clamps, for shield on busbars, for conductor diameters ≤ 14 mm, contact resistance < 1 m Ω	S20-SHIELD-SK14	R911173286	10
PEN conductor busbar, 3x10 mm, length: 1000 mm	S20-SHIELD-NLS	R911173283	1
Documentation	Type	MNR	Pcs./Pkt.
Application description S20: System and Installation	DOK-CONTRL- S20*SYS*INS-AP..-EN-P	R911335988	1
Application description S20: Error Messages	DOK-CONTRL- S20*DIAG*ER-AP..-EN-P	R911344826	1

Additional ordering data

For additional ordering data (accessories), please refer to the product catalog at www.boschrexroth.com/electrics.

4 Technical data

Dimensions (nominal sizes in mm)

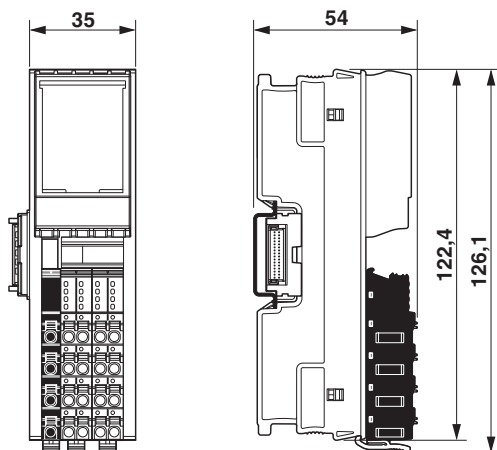

Width	35 mm
Height	126.1 mm
Depth	54 mm
Note on dimensions	The depth applies when a TH 35-7.5 DIN rail is used (in accordance with EN 60715).

General data

Color	light grey RAL 7035
Weight	144 g (with connectors and bus base module)
Ambient temperature (operation)	-25 °C ... 60 °C
Ambient temperature (storage/transport)	-40 °C ... 85 °C
Permissible humidity (operation)	5 % ... 95 % (non-condensing)
Permissible humidity (storage/transport)	5 % ... 95 % (non-condensing)
Air pressure (operation)	70 kPa ... 106 kPa (up to 3000 m above sea level)
Air pressure (storage/transport)	70 kPa ... 106 kPa (up to 3000 m above sea level)
Degree of protection	IP20
Protection class	III (IEC 61140, EN 61140, VDE 0140-1)
Overvoltage category	II (IEC 60664-1, EN 60664-1)
Degree of pollution	2 (IEC 60664-1, EN 60664-1)
Mounting type	DIN rail mounting
Mounting position	any (no temperature derating)

Connection data: S20 connector

Connection method	Push-in connection
Conductor cross section, rigid	0.2 mm ² ... 1.5 mm ²
Conductor cross section, flexible	0.2 mm ² ... 1.5 mm ²
Conductor cross section [AWG]	24 ... 16
Stripping length	8 mm



Observe the specifications for the conductor cross sections in the application description for the S20 system, material number R911335988.

Interface: Local bus

Number of interfaces	2
Connection method	Bus base module
Transmission speed	100 Mbps

Supply of the local bus (U_{Bus})

Supply voltage	5 V DC (via bus base module)
Current consumption	max. 140 mA
Power consumption	max. 700 mW

Supply for analog modules (U_A)

Supply voltage	24 V DC
Supply voltage range	19.2 V DC ... 30 V DC (including all tolerances, including ripple)
Current consumption	max. 17 mA
Power consumption	max. 400 mW
Surge protection	electronic (35 V, 0.5 s)
Reverse polarity protection	Polarity protection diode
Transient protection	Suppressor diode

Power consumption

Power consumption	max. 1.1 W (at U _{Bus} and U _A)
-------------------	--

Analog inputs	
Number of inputs	4 (for resistance temperature detectors)
Connection method	Push-in connection
Connection technology	2-, 3-, 4-conductor (shielded)
Sensor types (RTD) that can be used	Pt, Ni, KTY, Cu sensors
Linear resistance measuring range	0 Ω ... 500 Ω, 0 kΩ ... 5 kΩ
A/D converter resolution	24 bit
Measured value representation	16 bits (15 bits + sign bit)
Data formats	IB IL
Input filter time	40 ms, 60 ms, 100 ms, 120 ms (adjustable)
Tolerance, relative	see tables for tolerance values
Tolerance, absolute	typ. ± 0.1 K (Pt100 with 3-conductor connection) see tables for tolerance values
Short-circuit protection, overload protection of the inputs	yes
Transient protection of inputs	yes
Transient protection of sensor supplies	yes
Nominal value of the current sources	1 mA (Pt 100, Ni 100, R _{Lin} 500 Ω; pulse current, the specification is valid during the sampling phase) 210 μA (Pt1000, Ni 1000, R _{Lin} 5000 Ω; pulse current, the specification is valid during the sampling phase)
Differential non-linearity	typ. 1 ppm / ±0.0001% (in all ranges)
Integral non-linearity	typ. 30 ppm / ±0.003% (Pt 100) typ. 20 ppm / ±0.002% (R _{Lin} 500 Ω) typ. 200 ppm / ±0.02% (R _{Lin} 5000 Ω)
Input and output address area	
Input address area	8 Byte
Output address area	8 Byte
Configuration and parameter data in a PROFIBUS system	
Required parameter data	12 Byte
Required configuration data	6 Byte
Electrical isolation/isolation of the voltage areas	
Test section	Test voltage
5 V supply of the local bus (U _{Bus}) / 24 V supply (I/Os)	500 V AC, 50 Hz, 1 min.
5 V supply of the local bus (U _{Bus})/analog inputs	500 V AC, 50 Hz, 1 min.
5 V supply of the local bus (U _{Bus}) / functional ground	500 V AC, 50 Hz, 1 min.
24 V supply (I/O)/analog inputs	500 V AC, 50 Hz, 1 min.
24 V supply (I/O) / functional ground	500 V AC, 50 Hz, 1 min.
Analog inputs/functional ground	500 V AC, 50 Hz, 1 min.
Mechanical tests	
Vibration resistance in accordance with EN 60068-2-6/IEC 60068-2-6	5g
Shock in accordance with EN 60068-2-27/IEC 60068-2-27	30g
Continuous shock in accordance with EN 60068-2-27/IEC 60068-2-27	10g

Conformance with EMC Directive 2014/30/EU**Immunity test in accordance with EN 61000-6-2/IEC 61000-6-2**

Electrostatic discharge (ESD) EN 61000-4-2/IEC 61000-4-2	Criterion B, 6 kV contact discharge, 8 kV air discharge
Electromagnetic fields EN 61000-4-3/IEC 61000-4-3	Criterion A, Field intensity: 10 V/m
Fast transients (burst) EN 61000-4-4/IEC 61000-4-4	Criterion B, 2 kV
Transient overvoltage (surge) EN 61000-4-5/IEC 61000-4-5	Criterion B, DC supply lines: ± 0.5 kV/ ± 1.0 kV (symmetrical/unsymmetrical), ± 1.0 kV to shielded I/O cables
Conducted interference EN 61000-4-6/IEC 61000-4-6	Criterion A, Test voltage 10 V
Noise emission test in accordance with EN 61000-6-3/IEC 61000-6-3	Class B

Approvals

For the current approvals, please visit www.boschrexroth.com/electrics.

5 Additional technical data

Sampling times for different filter times		
Filter time	Typical scan repeat time for all four measuring channels	Typical scan time for each measuring channel
120 ms	1.64 s	410 ms
100 ms	1.5 s	375 ms
60 ms	1.16 s	290 ms
40 ms	1.0 s	250 ms

Common mode rejection with different filter times		
Filter time	Optimization of common mode rejection for the interference frequency	Typical common mode rejection for measuring inputs of analog/digital converters (CMRR)
120 ms	50 Hz	80 dB (at 50 Hz)
100 ms	60 Hz	90 dB (at 60 Hz)
60 ms	-	-
40 ms	-	-

Connecting cable and maximum cable length specifications		
Connection technology	Maximum permissible cable length	Sensor type
4-conductor	250 m	All
3-conductor	100 m	All
2-conductor	20 m	Pt 1000, Ni 1000, R_{Lin} 5000 Ω
2-conductor	3 m	Pt 100, Ni 100, R_{Lin} 500 Ω

The maximum cable length specification is valid from the sensor to the connection terminal block and includes the maximum specified tolerances.

With 2-conductor connection, longer cable lengths can lead to increased measuring tolerances.

The specifications are valid when using the reference cable type LiYCY (TP) 2*2*0.5 mm² and observing the S20 installation guidelines.

6 Temperature and resistance measuring ranges

Supported measuring ranges			
Sensor type	Standard and manufacturer specification	Measuring range	
		Lower limit	Upper limit
Pt sensors (e.g., Pt 100, Pt 500, Pt 1000)	DIN IEC 60751 or SAMA RC 21-4-1966	-200 °C	+850 °C
Ni sensors (e.g., Ni 100, Ni 1000)	DIN 43760	-60 °C	+180 °C
Ni 500 (Viessmann)	(Viessmann)	-60 °C	+250 °C
Ni 1000 (Landis & Gyr)	(Landis & Gyr)	-50 °C	+160 °C
KTY 81-110	(Philips)	-55 °C	+150 °C
KTY 81-210	(Philips)	-55 °C	+150 °C
KTY 84	(Philips)	-40 °C	+300 °C
Cu 10	SAMA RC 21-4-1966	-70 °C	+500 °C
Cu 50	SAMA RC 21-4-1966	-50 °C	+200 °C
Cu 53	SAMA RC 21-4-1966	-50 °C	+180 °C
Linear resistor R_{Lin} 500 Ω (linear range 1)		0 Ω	500 Ω
Linear resistor R_{Lin} 5000 Ω (linear range 2)		0 Ω	5000 Ω



The linear input ranges have an additional overflow range of 5% of the measuring range final value. For linear input ranges, the measuring range around the zero point may be limited by $\pm 0.03\%$. If a short-circuit occurs or there is a resistance value of $R = 0.0 \Omega$, the "Underrange" message ($8080_{hex}/32896_{dec}$) may appear in the process data.

7 Tolerance data

MRFV= Measuring range final value

The data contains the offset error, gain error, and linearity error in its respective setting.

To determine the overall tolerance, please also take into consideration the values for temperature drift (see tables in section "Temperature and drift response").

Typical tolerance values are measured application values that are based on the maximum variance of all test objects.

The **maximum tolerance values** represent the worst-case measurement inaccuracy. They contain the theoretical maximum possible tolerances in the corresponding measuring ranges as well as the theoretical maximum possible tolerances of the calibration and test equipment. The data is valid for at least 24 months from delivery of the module. Thereafter the modules can be recalibrated by the manufacturer at any time.

7.1 Tolerances in 3-conductor technology at 25°C

Measuring conditions:

- Nominal operation $U_A = 24 \text{ V}$
- Connection of sensors in 3-conductor technology
- Filter of RTD inputs 120 ms
- All channels are connected
- Installation on horizontal DIN rail on the wall
- Reference cable type LiYCY (TP) 2*2*0.5 mm² with a connection length of < 1 m

No.	Sensor type	Measuring range		Absolute tolerance		Relative tolerance (with reference to MRFV)	
		Lower limit	Upper limit	Typical	Maximum	Typical	Maximum
1	Pt 100 DIN and SAMA	-200 °C	+200 °C	±0.10 K	±0.38 K	±0.05 %	±0.19 %
2	Pt 100 DIN and SAMA	-200 °C	+850 °C	±0.13 K	±0.55 K	±0.02 %	±0.06 %
3	Pt 1000 DIN and SAMA	-200 °C	+850 °C	±0.15 K	±0.68 K	±0.02 %	±0.08 %
4	Ni 100	-60 °C	+180 °C	±0.05 K	±0.12 K	±0.03 %	±0.07 %
5	Ni 1000	-60 °C	+180 °C	±0.09 K	±0.46 K	±0.05 %	±0.26 %
6	Ni 1000 (Landis & Gyr)	-50 °C	+160 °C	±0.09 K	±0.49 K	±0.06 %	±0.31 %
7	KTY 81-110	-55 °C	+150 °C	±0.08 K	±0.41 K	±0.05 %	±0.27 %
8	KTY 84 (KTY 84-130, KTY 84-150)	-55 °C	+150 °C	±1.20 K		±0.80 %	
9	KTY 81-210	-55 °C	+150 °C	±0.05 K		±0.03 %	
10	Cu 10	-70 °C	+500 °C				
11	Cu 50	-50 °C	+200 °C				
12	Cu 53	-50 °C	+180 °C				
13	Linear resistor R_{Lin} 500 Ω (linear range 1)	0 Ω	500 Ω	±0.12 Ω	±2.35 Ω	±0.02 %	±0.47 %
14	Linear resistor R_{Lin} 5000 Ω (linear range 2)	0.1 Ω	5000 Ω	±0,50 Ω	±6.5 Ω	±0.01 %	±0.13 %

7.2 Tolerances in 4-conductor technology at 25°C

Measuring conditions:

- Nominal operation $U_A = 24\text{ V}$
- Connection of sensors in 4-conductor technology
- Filter of RTD inputs 120 ms
- All channels are connected
- Installation on horizontal DIN rail on the wall
- Reference cable type LiYCY (TP) 2*2*0.5 mm² with a connection length of < 1 m

No.	Sensor type	Measuring range		Absolute tolerance		Relative tolerance (with reference to MRFV)	
		Lower limit	Upper limit	Typical	Maximum	Typical	Maximum
1	Pt 100 DIN and SAMA	-200 °C	+200 °C	±0.05 K	±0.25 K	±0.03%	±0.13 %
2	Pt 100 DIN and SAMA	-200 °C	+850 °C	±0.10 K	±0.42 K	±0.01 %	±0.05 %
3	Pt 1000 DIN and SAMA	-200 °C	+850 °C	±0.13 K	±0.60 K	±0.03%	±0.10 %
4	Ni 100	-60 °C	+180 °C	±0.04 K	±0.12 K	±0.02 %	±0.07%
5	Ni 1000	-60 °C	+180 °C	±0.09 K	±0.43 K	±0.05 %	±0.24 %
6	Ni 1000 (Landis & Gyr)	-50 °C	+160 °C	±0.09 K	±0.47 K	±0.06 %	±0.29%
7	KTY 81-110	-55 °C	+150 °C	±0.08 K	±0.38 K	±0.03%	±0.10 %
8	KTY 84 (KTY 84-130, KTY 84-150)	-55 °C	+150 °C	±1.20 K		±0.80 %	
9	KTY 81-210	-55 °C	+150 °C	±0.05 K		±0.03%	
10	Cu 10	-70 °C	+500 °C				
11	Cu 50	-50 °C	+200 °C				
12	Cu 53	-50 °C	+180 °C				
13	Linear resistor R_{Lin} 500 Ω (linear range 1)	0 Ω	500 Ω	±0.12 Ω	±2.35 Ω	±0.02 %	±0.47 %
14	Linear resistor R_{Lin} 5000 Ω (linear range 2)	0.1 Ω	5000 Ω	±0,50 Ω	±6.5 Ω	±0.03%	±0.13 %

7.3 Tolerances influenced by electromagnetic interference

Type of electromagnetic interference	Standard	Level	Additional tolerances of measuring range final value	Criterion
Electromagnetic fields	EN 61000-4-3/ IEC 61000-4-3	10 V/m	none	A
Fast transients (burst)	EN 61000-4-4/ IEC 61000-4-4	1.1 kV	None	A
Conducted interference	EN 61000-4-6/ IEC 61000-4-6	150 kHz ... 80 MHz, 10 V, 80 % (1 kHz)	None	A

The data was determined under nominal conditions with the following parameterization: R_{Lin} : 500 Ω , resolution: 0.01 K, 4-conductor connection, filter: 120 ms.

The set-up was implemented in accordance with the installation guidelines (with shielded I/O cables).



No additional tolerances occur due to the influence of high-frequency interference caused by wireless transmission systems in the near vicinity.

The specifications refer to nominal operation. The modules are directly exposed to interference without the use of additional shielding measures (e.g., steel cabinet).

8 Temperature and drift response



Please also observe the calculation examples at the end of the document.

8.1 Tolerance and temperature response (drift behavior) for 3-conductor connection

Tolerance and temperature response at $T_A = -25\text{ °C} \dots +60\text{ °C}$				
Sensor type	Measuring range		Drift	
	Lower limit	Upper limit	Typical	Maximum
Pt 100 DIN and SAMA	-200 °C	+200 °C	±3 ppm/K	±18 ppm/K
Pt 100 DIN and SAMA	-200 °C	+850 °C	±5 ppm/K	±18 ppm/K
Pt 1000 DIN and SAMA	-200 °C	+850 °C	±20 ppm/K	±65 ppm/K
Ni 100 DIN and SAMA	-60 °C	+180 °C	±4 ppm/K	±20 ppm/K
Ni 1000 DIN and SAMA	-60 °C	+180 °C	±23 ppm/K	±75 ppm/K
Linear resistor R_{Lin} 500 Ω (linear range 1)	0 Ω	500 Ω	±5 ppm/K	±20 ppm/K
Linear resistor R_{Lin} 5000 Ω (linear range 2)	0 Ω	5000 Ω	±34 ppm/K	±95 ppm/K

8.2 Tolerance and temperature response (drift behavior) for 4-conductor connection

Tolerance and temperature response at $T_A = -25\text{ °C} \dots +60\text{ °C}$				
Sensor type	Measuring range		Drift	
	Lower limit	Upper limit	Typical	Maximum
Pt 100 DIN and SAMA	-200 °C	+200 °C	±3 ppm/K	±18 ppm/K
Pt 100 DIN and SAMA	-200 °C	+850 °C	±3 ppm/K	±18 ppm/K
Pt 1000 DIN and SAMA	-200 °C	+850 °C	±18 ppm/K	±65 ppm/K
Ni 100 DIN and SAMA	-60 °C	+180 °C	±2 ppm/K	±20 ppm/K
Ni 1000 DIN and SAMA	-60 °C	+180 °C	±24 ppm/K	±75 ppm/K
Linear resistor R_{Lin} 500 Ω (linear range 1)	0 Ω	500 Ω	±4 ppm/K	±20 ppm/K
Linear resistor R_{Lin} 5000 Ω (linear range 2)	0 Ω	5000 Ω	±25 ppm/K	±80 ppm/K

Typical drift values have been determined under nominal conditions with a filter of 120 ms. All channels were connected and parameterized in the same way.

Typical tolerance values are measured application values that are based on the maximum variance of all test objects.

Hardly any typical drift influences can be determined in the temperature range from $T_A = +25\text{ °C}$ to $+60\text{ °C}$. The documented typical drift values basically occur in the temperature range from $T_A = -25\text{ °C}$ to $+25\text{ °C}$.

The **maximum values** represent the worst case measurement inaccuracy.

8.3 Absolute tolerances with a Pt 100 sensor at $T_A = -25^\circ\text{C} \dots +60^\circ\text{C}$

Measuring conditions:

- Nominal operation $U_A = 24\text{ V}$
- Filter of RTD inputs 120 ms
- Installation on horizontal DIN rail on the wall
- Reference cable type LiYCY (TP) $2 \times 2 \times 0.5\text{ mm}^2$ with a connection length $<100\text{ m}$ (with 3-conductor technology)
- Reference cable type LiYCY (TP) $2 \times 2 \times 0.5\text{ mm}^2$ with a connection length $<250\text{ m}$ (with 4-conductor technology)

Tolerances at $T_A = -25^\circ\text{C} \dots +60^\circ\text{C}$					
Sensor type (4-conductor connection)	Measuring range (nominal range)		Connection technology	Absolute tolerance	
	Lower limit	Upper limit		Typical	Maximum
Pt 100 DIN and SAMA	-200°C	$+200^\circ\text{C}$	4-conductor	$\pm 0.08\text{ K}$	$\pm 0.43\text{ K}$
Pt 100 DIN and SAMA	-200°C	$+200^\circ\text{C}$	3-conductor	$\pm 0.15\text{ K}$	$\pm 0.56\text{ K}$

The data contains the offset error, gain error, and linearity error in its respective setting.

Typical tolerance values are measured application values that are based on the maximum variance of all test objects.

The **maximum tolerance values** represent the theoretical worst case measurement inaccuracy. Besides the maximum offset error and gain error, the maximum tolerance values also comprise the longtime drift as well as the maximum tolerances of the test and calibration equipment.

9 Internal circuit diagram

Fig. 1 Internal wiring of the terminal points

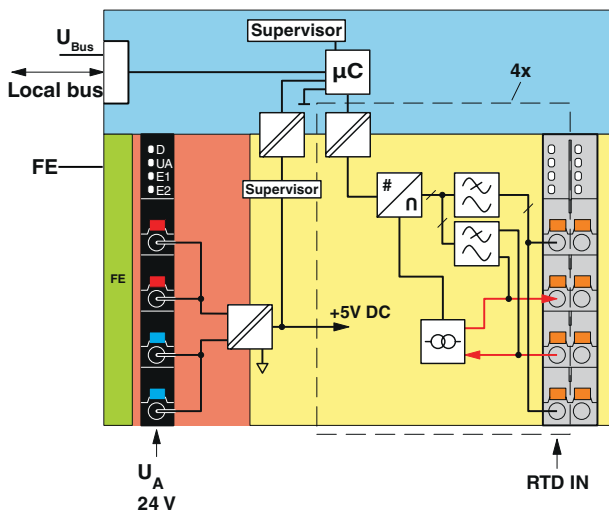

Key:

FE Functional ground

Local bus Local bus



Microcontroller



Electrical isolation for data or power supply

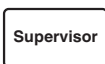

Hardware monitoring



Analog/digital converter



Low pass filter



Constant current source



Electrically isolated areas

10 For your safety

10.1 Intended use

Only use S20 modules in accordance with the information in this data sheet and in the application description for the S20 system, material number R911335988.

10.2 Qualification of users

The use of products described in this data sheet is oriented exclusively to electrically skilled persons or persons instructed by them. The users must be familiar with the relevant safety concepts of automation technology as well as applicable standards and other regulations.

10.3 Electrical safety



WARNING: loss of electrical safety

If used incorrectly, device safety may be impaired.

During installation, startup, and operation, observe the notes in this data sheet and the specifications in the application description for the S20 system, material number R911335988.

10.4 Installation

Only install the S20 modules in a control cabinet or junction box.

The enclosure must meet the requirements regarding the protection against spread of fire according to the following standards:

- EN 61010-1/IEC 61010-1
- UL 61010-1 (for applications with UL approval)

11 Terminal point assignment

Fig. 2 Terminal point assignment

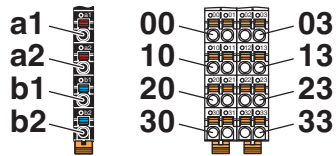

Terminal point	Color	Assignment	
Supply voltage input			
a1, a2	Red	24 V DC (U _A)	Analog module feed-in (bridged internally)
b1, b2	Blue	GND	Reference potential of the supply voltage (bridged internally)
Analog inputs			
00 ... 03	Orange	U01+ ... U04+	RTD sensor + channel 1 ... 4
10 ... 13	Orange	I01+ ... I04+	Constant current supply + channel 1 ... 4
20 ... 23	Orange	I01- ... I04-	Constant current supply - channel 1 ... 4
30 ... 33	Orange	U01- ... U04-	RTD sensor - channel 1 ... 4

12 Connection examples

12.1 4-conductor connection

Fig. 3 Connection example: 4-conductor connection

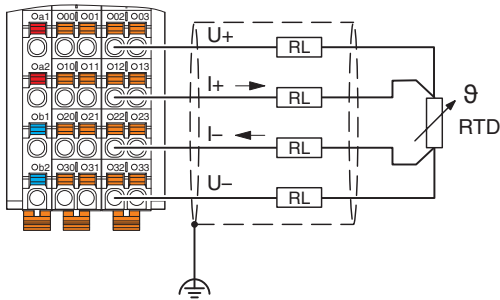

12.2 3-conductor connection

Fig. 4 Connection example: 3-conductor connection

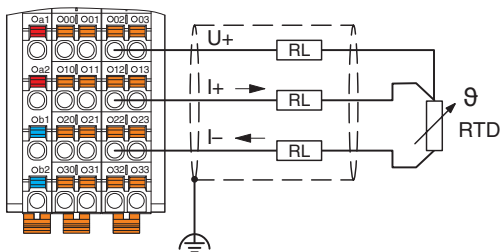

12.3 2-conductor connection

Fig. 5 Connection example: 2-conductor connection

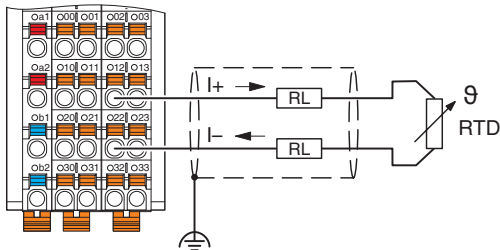

12.4 4-conductor connection using a sensor in 3-conductor technology

In order to also measure 3-conductor sensors with very long supply lines without additional tolerances, we also recommend 4-conductor connection technology here.

To do so, configure the channel as a 4-conductor channel and bridge the connections Ix- and Ux- on the sensor side.

In this application you can connect sensors with a cable length up to 250 m.

Fig. 6 Connection example: 4-conductor connection for 3-conductor sensor with very long supply lines (> 100 m)

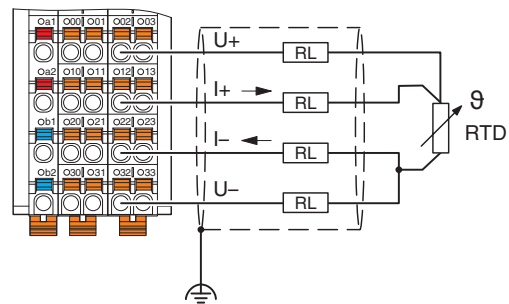

13 Connection notes

NOTE Damage to the electronics/measuring error

Unshielded cables may lead to values outside the specified tolerance limits in environments subject to heavy noise.

Shielded, twisted connecting cables (e.g., Li-YCY (TP 2*2*0.5 mm²)) must be used in environments subject to heavy noise as well as for sensor cables longer than 1 m.

- Always connect the analog sensors using shielded, twisted pair cables.

Connect the cable shield to functional earth immediately after the cables enter the control cabinet.

If a closed control cabinet is not available, connect the shield to a shield bus.

For the best possible connection directly in front of the module, use the S20 SHIELD-SET shield connection set (R911173030) in combination with the S20-SHIELD-NLS busbar (R911173283).



For more information on shielding, please refer to the application description for the S20 system, material number R911335988.

14 Local diagnostic and status indicators

Fig. 7 Local diagnostic and status indicators

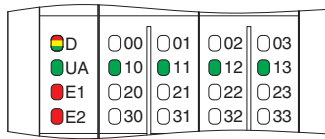

Channel errors are errors that can be associated with a channel.

I/O errors are errors that affect the entire module.

Designation	Color	Meaning	State	Description
D	Red/yellow/green	Diagnostics of local bus communication		
		Run	Green on	The device is ready for operation, communication within the station is OK. All data is valid. An error has not occurred.
		Active	Flashing green	The device is ready to operate, communication within the station is OK. The data is not valid. The controller or higher-level network is not delivering valid data. There is no error on the module.
		Device application not active	Flashing green/yellow	The device is ready for operation, communication within the station is OK. Output data cannot be outputted and/or input data cannot be read. There is a fault on the periphery side of the module..
		Ready	Yellow on	The device is ready for operation but did not detect a valid cycle after power-up.
		Connected	Flashing yellow	The device is not (yet) part of the active configuration.
		Reset	Red on	The device is ready for operation but has lost the connection to the bus head.
		Not connected	Flashing red	The device is ready for operation but there is no connection to the previously existing device.
Power down	Off	Device is in (power) reset.		
UA	Green	U _{Analog}	On	Supply for analog modules (U _A) present.
			Off	Supply for analog modules (U _A) not present.
E1	Red	Supply voltage error	On	Supply for analog modules (U _A) is faulty.
			Off	Supply for analog modules (U _A) is OK.
E2	Red	Error	On	I/O or channel error has occurred.
			Off	No error
10 ... 13	Red/orange/green	Channel Scout/error message		
		Channel Scout	Flashing orange	Channel searched for
		Error message	Red on	Wire break, overrange or underrange Errors which affect the entire device (e.g., parameter table invalid); Such errors are only displayed on active channels.
		OK	Green on	Normal operation
		Inactive	Off	Channel is parameterized as inactive.

Error code and status of the E1 and E2 LEDs

Error	E1 LED	E2 LED
No error	off	off
Underrange	off	on
Overrange	off	on
Wire break	off	on
Supply voltage faulty (supply for analog modules (U _A))	on	on
Parameter table invalid	off	on
Device error	off	on
Flash format error	off	on

15 Diagnostic behavior in the event of an error

The following error states are diagnosed and indicated by the module. They are indicated in the diagnostic object (PDI object 0018_{hex}), at the corresponding local diagnostic indicators, and, when IB IL format is set, in the input process data.

Error	Indication in the process data		Messages via the "Diagnostics" object			Local diagnostic indicators
U _L missing	None (local bus without supply)		None			All LEDs are off. (Exception: UA LED)
Measured value is above the valid measuring range (e.g., 500 Ω at Pt 100 input)	8001 _{hex}	Measuring range violated (overrange)	8910 _{hex}	Overrange	Warning, priority 2	LED of the affected channel (10 ... 13) lights up red E2 LED lights up red
Sensor connector is not connectorged in, the sensor cable is completely interrupted						LED of the affected channel (10 ... 13) lights up red E2 LED lights up red
- "Wire-break detection" bit = 0 (default)*	8002 _{hex}	Wire break	7710 _{hex}	Open circuit	Error, priority 1	
- "Wire-break detection" bit = 1*	8001 _{hex}	Measuring range violated (overrange)	8910 _{hex}	Overrange	Warning, priority 2	
Measured value invalid (e.g., if channel is inactive)	8004 _{hex}	Measured value is invalid	No			None
U _A (24 V) is missing or failure of internal I/O voltages	8020 _{hex}	Faulty supply voltage	5160 _{hex}	Supply fail	Error, priority 1	The E1 and E2 LEDs light up red LEDs 10 ... 17 of the active channels light up red
Internal component faulty	8040 _{hex}	Device faulty	6301 _{hex}	CS FLASH	Error, priority 1	LED E2 lights up red LEDs 10 ... 17 of the active channels light up red
			6302 _{hex}	FO FLASH		
Measured value is below the valid measuring range (e.g., 5 Ω at Pt 100 input)	8080 _{hex}	Measuring range violated (underrange)	8920 _{hex}	Underrange	Warning, priority 2	LED of the affected channel (10 ... 13) lights up red E2 LED lights up red
* See section "Parameter table (0080 _{hex} : ParaTable)", "Data format, system bits".						

16 Process data

The module uses four words of IN process data.

The measured values are transmitted to the controller board or the computer using process data input words.

Each channel is mapped to a word.

The process data is mapped in Motorola format (Big Endian).

IN process data

The measured values are transmitted to the controller board or the computer by means of the process data input words IN0 to IN3.

The I/O data is mapped as follows.

15	14	13	12	11	10	9	8	7	6	5	4	3	2	1	0
V	Analog value														

V Sign bit

In the IB IL format a diagnostic code is mapped to the input data in the event of an error.

Code (hex)	Cause
8001	Measuring range exceeded (overrange)
8002	Wire break
8004	Measured value invalid or no valid measured value available
8010	Parameter table invalid
8020	Faulty supply voltage
8040	Device faulty
8080	Below measuring range (underrange)



As long as a used channel is not parameterized, the relevant status LED is OFF and the code 8004_{hex} is transmitted in the process data.

17 Significant values

Input data		R 0 Ω ... 500 Ω		R 0 Ω ... 5 kΩ		Temperature sensors	
Resolution		0.1 Ω	0.01 Ω	1 Ω	0.1 Ω	0.1°C or 0.1°F	0.01°C or 0.01°F
hex	dec	Ω	Ω	Ω	Ω	°C or °F	°C or °F
8001	Overrange	> 525	> 325.12	> 5250	> 3251.2	> Limit value	> Limit value
03E8	1000	+100.0	+10.0	+1000.0	+100.0	+100.0	+10.0
0001	1	+0.1	+0.01	+1.0	+0.1	+0.1	+0.01
0000	0	≤ 0	≤ 0	≤ 0	≤ 0	0	0
FFFF	-1					-0.1	-0.01
FC18	-1000					-100.000	-10.0
8080	Underrange					< Limit value	< Limit value

18 Parameter, diagnostics and information (PDI)

Parameter and diagnostic data as well as other information is transmitted as objects via the PDI channel of the S20 station.

In IndraWorks, these parameters are displayed in the configurator.

The standard and application objects stored in the module are described in the following section.

The following applies to all tables below:

For an explanation of the data types, please refer to the application description for the S20 system, material number R911335988.

Abbreviation	Meaning
A	Number of elements
L	Length of the elements in bytes
R	Read
W	Write



Each visible string is terminated with a null terminator (00_{hex}). The length of a visible-string-type element is therefore at least one byte larger than the number of user data items.

If the number of user data items plus null terminator is smaller than the specified length of the element, the visible string will be populated with a null character (00_{hex}).



For detailed information on PDI objects, please refer to the application description for the S20 system, material number R911335988.

19 Standard objects

19.1 Objects for identification (device rating plate)

Index (hex)	Object name	Data type	A	L	Rights	Meaning	Contents
Manufacturer							
0001	VendorName	Visible String	1	17	R	Vendor name	Bosch Rexroth AG
0002	VendorID	Visible String	1	7	R	Vendor ID	006034
0012	VendorURL	Visible String	1	28	R	Vendor URL	http://www.boschrexroth.com
Module - general							
0004	DeviceFamily	Visible String	1	14	R	Device family	I/O analog IN
0006	ProductFamily	Visible String	1	17	R	Product family	IndraControl S20
000E	CommProfile	Visible String	1	4	R	Communication profile	633
000F	DeviceProfile	Visible String	1	5	R	Device profile	0010
0011	ProfileVersion	Record of Visible Strings	2	11; 21	R	Profile version	2011-12-07; Basic - Profile V2.0
0017	Language	Record of Visible Strings	2	6; 8	R	Language	en-us; English
Module - special							
0005	Capabilities	Visible String	1	8	R	Capabilities	Energ_0
0007	ProductName	Visible String	1	10	R	Product name	S20-AI-4-RTD
0008	SerialNo	Visible String	1	16	R	Serial number	xx xx xx xx xx xx xx x (e. g., 7602012346BC125)
0009	ProductText	Visible String	1	24	R	Product text	4 analog input channels
000A	OrderNumber	Visible String	1	11	R	Item No.	R911173341
000B	HardwareVersion	Record of Visible Strings	2	11; 4	R	Hardware version	e.g., 2020-04-26; AA1
000C	FirmwareVersion	Record of Visible Strings	2	11; 6	R	Firmware version	e. g., 2010-06-21; V1.10
000D	PChVersion	Record of Visible Strings	2	11; 6	R	PDI version	2010-01-08; V1.00
0037	DeviceType	Octet string	1	8	R	Device type	00 20 00 08 00 00 00 A4 _{hex}
003A	VersionCount	Array of UINT16	4	4 * 2	R	Version counter	e. g., 0007 0001 0001 0001 _{hex}
Use of the device							
0014	Location	Visible String	1	58	R/W	Location	Can be completed by the user.
0015	EquipmentIdent	Visible String	1	58	R/W	Equipment identifier	Can be completed by the user.
0016	AppIDeviceAddr	UINT16	1	2	R/W	Application-specific device address	Can be completed by the user.

19.2 Miscellaneous standard objects

Index (hex)	Object name	Data type	A	L	Rights	Meaning/contents	Startup parameters
Diagnostics objects							
0018	DiagState	Record	6	2; 1; 1; 2; 1; 14	R	Diagnostic state	No *
0019	ResetDiag	UINT8	1	1	R/W	Handling diagnostic messages	No *
Objects for process data management							
0025	PDIN	Octet string	1	8	R	Input process data The structure corresponds to the representation in the "Process data" section.	No
0026	PDOOUT	Octet string	1	8	R	OUT process data, not applicable	No

The objects identified with * in the last column are described in more detail in the following sections.

The description of the other objects is to be found in the application description for the S20 system, material number R911335988.

19.3 Diagnostics state (0018_{hex}: DiagState)

This object is used for a structured message of an error.

0018 _{hex} : Diagnostics state (read)					
Subindex	Data type	Length in bytes	Meaning	Contents	
0	Record	21	Diagnostic state	Complete diagnostics information	
1	UINT16	2	Error number	0 ... 65535 _{dec}	
2	UINT8	1	Priority	00 _{hex}	No error
				01 _{hex}	Error
				02 _{hex}	Warning
				81 _{hex}	Error removed
				82 _{hex}	Warning eliminated
3	UINT8	1	Channel/group/module	00 _{hex}	No error
				01 _{hex}	Channel 1
				:	:
				04 _{hex}	Channel 4
				FF _{hex}	Entire device
4	UINT16	2	Error code	See table below	
5	UINT8	1	More follows	00 _{hex}	
6	Visible String	14	Text	See table below	



The message with priority 81_{hex} or 82_{hex} is a one-off, internal message to the bus coupler. The bus coupler transfers this error message to the error mechanisms of the higher-level system.



Once the cause of the fault has been removed, the message is automatically reset.

Error and status of the local diagnostics and status indicators

Subindex	2	3	4	6		LED				
Error	Priority	Chan- nel/ group/ module	Error code	Text	Process data	D	UA	E1	E2	10 ... 13
	hex	hex	hex							
No error	00	00	0000	Status OK	xxxx	○	●	○	○	X
Supply voltage faulty (supply for analog modules (U _A))	01	FF	5160	Supply fail	8020	⊗	○	●	●	○
Device error	01	FF	6301	CS FLASH	8040	○	●	○	●	○
Flash format error	01	FF	6302	FO FLASH	8040	○	●	○	●	○
Parameter table invalid	01	FF	6320	Invalid para	8010	○	●	○	●	○
Wire break (default)	01	01 ... 04	7710	Open circuit	8002	○	●	○	●	○
Wire break ("Wire-break de- tection" bit = 1*)	02	01 ... 04	8910	Overrange	8001	○	●	○	●	○
Overrange	02	01 ... 04	8910	Overrange	8001	○	●	○	●	○
Underrange	02	01 ... 04	8920	Underrange	8080	○	●	○	●	○

* See section "Parameter table (0080hex: ParaTable)", "Data format, system bits".

X	The LED is not affected by this error.	○	Green on
○	Off	●	Red on
●	On	⊗	Flashing green/yellow

-  An error at a channel (channel = 01 ... 04) is indicated via the corresponding LED (LED 10 ... 13).
 An error which affects the entire device (channel = FF), is only indicated on active channels via LEDs 10 ... 13. The corresponding LED is off for inactive channels.

19.4 Handling diagnostic messages (0019_{hex}: ResetDiag)

You can use this object to specify how the module should handle diagnostic messages.

0019 _{hex} : Handling diagnostic messages (read, write)				
Subindex	Data type	Length in bytes	Code (hex)	Meaning
0	UINT8	1	00	Permit all diagnostic messages
			02	Delete and acknowledge all diagnostic messages that are still pending
			06	Delete and acknowledge all diagnostic messages and do not permit new diagnostic messages
			Other	Reserved

20 Application objects

Index (hex)	Object name	Data type	A	L	Rights	Meaning/contents	Startup parameters
0080	ParaTable	Array of UINT16	6	6 * 2	R/W	Parameter table	Yes
0082	Measured Value Float	Array of Records	4	4 * 6	R	Measured values in the extended float format	No
0083	PD Min	Array of INT16	4	4 * 2	R	Minimum process data value	No
0084	PD Max	Array of INT16	4	4 * 2	R	Maximum process data value	No
0090	Channel Scout	UINT8	1	1	R/W	Channel Scout	No

Startup parameters are stored permanently in the Flash memory.

20.1 Parameter table (0080_{hex}: ParaTable)

Parameterize the module using this object.

In the case of valid parameters, the parameterization is stored in the module permanently.

After resetting, the module works with the last permanently stored data. Upon delivery, the module works with the default data (default settings).

0080 _{hex} : Parameter table (read, write)				
Subindex	Data type	Length in bytes	Meaning	Default value
0	Array of UINT16	6 * 2	Read/write all elements	See subindices
1	UINT16	2	Parameterization of channel 1	000F _{hex}
:	UINT16	2	:	000F _{hex}
4	UINT16	2	Parameterization of channel 4	000F _{hex}
5	UINT16	2	Data format, system bits	0000 _{hex}
6	UINT16	2	Reserved	0000 _{hex}

Parameterization channel 1 ... channel 4

Parameterization word

15	14	13	12	11	10	9	8	7	6	5	4	3	2	1	0
Conductor		Filter		R0		Resolution		0	0	Sensor type					

Connection method (wire):

Conductor	Code (bin)	Code (hex)
3-conductor (default)	00	0
2-conductor	01	1
4-conductor	10	2
Reserved	11	3

Filter:

Filter		Code (bin)	Code (hex)
120 ms (default)	8.3 Hz	00	0
100 ms	10 Hz	01	1
60 ms	16.6 Hz	10	2
40 ms	25 Hz	11	3

Resolution:

Resolution	Code (bin)	Code (hex)
0.1 °C (default)	00	0
0.01 °C	01	1
0.1 °F	10	2
0.01 °F	11	3

Resistance type (R0):

Parameterization of the resistance type is only useful for Pt and Ni sensors (DIN and SAMA). For other sensors the resistance type does not have to be parameterized.

R0 (Ω)	Code (bin)	Code (hex)
100 (default)	0000	0
10	0001	1
20	0010	2
30	0011	3
50	0100	4
120	0101	5
150	0110	6
200	0111	7
240	1000	8
300	1001	9
400	1010	A
500	1011	B
1000	1100	C
1500	1101	D
2000	1110	E
Reserved	1111	F

Sensor type:

Sensor type	Code (bin)	Code (hex)
Pt DIN	0000	0
Pt SAMA	0001	1
Ni DIN	0010	2
Ni SAMA	0011	3
Cu 10	0100	4
Cu 50	0101	5
Cu 53	0110	6
Ni 1000 (L&G)	0111	7
Ni 500 (Viessmann)	1000	8
KTY 81-110	1001	9
KTY 84 (KTY 84-130, KTY 84-150)	1010	A
KTY 81-210	1011	B
Reserved	1100	C
Linear R 0 Ω ... 500 Ω	1101	D
Linear R 0 Ω ... 5 kΩ	1110	E
Channel inactive (default)	1111	F



For the sensor types 0_{hex} to 3_{hex} parameterize the resistance type as well.



Unused channels indicate a wire break diagnosis. To not receive a diagnostic message, set unused channels to "Channel inactive".

Possible resolutions for the individual sensor types

Resolution for sensor type				
Temperature sensors	Linear R 0 Ω ... 500 Ω	Linear R 0 Ω ... 5 kΩ	Code (bin)	Code (hex)
0.1 °C	0.1 Ω	1 Ω	00	0
0.01 °C	0.01 Ω	0.1 Ω	01	1
0.1 °F	0.1 Ω	1 Ω	10	2
0.01 °F	0.01 Ω	0.1 Ω	11	3

Data format, system bits

15	14	13	12	11	10	9	8	7	6	5	4	3	2	1	0
0	0	0	0	0	B	Data format		0	0	0	0	0	0	0	K

B: wire-break detection	Code (bin)	Code (hex)
Wire-break detection active (default)	0	0
Wire-break detection disabled	1	1



Wire-break monitoring is always active. You can specify whether and how the wire break should be indicated via the bit.

- **Bit 10 = 0 (default):**
In the delivery state, an error message is generated in the event of a wire break.
- **Bit 10 = 1:**
In the case of extreme EMC requirements, i.e., in the event of interference far above the industry standard, you can set the bit to specify that a warning should be indicated instead of an error.
- The bit does not influence the behavior of the LEDs.
- See section “Diagnostic behavior in the event of an error”.

Data format	Code (bin)	Code (hex)
IB IL (default)	00	0
Reserved	Other	

K: Temperature drift compensation	Code (bin)	Code (hex)
Compensation active (default)	0	0
Compensation inactive	1	1

20.2 Measured value in extended float format (0082_{hex}: Measured Value Float)

You can read the IN process data with the 0025_{hex} object.

The 0082_{hex} object is also available.

This object provides the measured value in the highest internal accuracy of the terminal in the float format.

0082 _{hex} : Measured value in extended float format (read)			
Subindex	Data type	Length in bytes	Meaning
0	Array of Records	4 * 6	Read all elements
1	Record	6	Measured value for channel 1
:	:	:	:
4	Record	6	Measured value channel 4

Measured value channel 1 ... channel 4

Element	Data type	Length in bytes	Meaning
1	FLOAT32	4	Measured value in float format according to IEEE 754
2	UINT8	1	Status
3	UINT8	1	Unit

Structure of the float format according to IEEE 754 in the bit representation:

VEEE EEEE	EMMM MMMM	MMMM MMMM	MMMM MMMM
-----------	--------------	--------------	--------------

V 1 sign bit, 0: positive, 1: negative

E 8 bits exponent with offset 7F_{hex}

M 23 bits mantissa

Example values for conversion from floating point to hexadecimal representation:

Floating point	Hexadecimal representation
1.0	3F 80 00 00
10.0	41 20 00 00
1.03965528	3F 85 13 6D
-1.0	BF 80 00 00

Extended Float Format

Extended Float Format is a specially defined format. It consists of the measured value in float format, a status, and a unit.

Status is necessary because the float format defines no patterns providing information on the status of the numerical value.

The status corresponds to the LSB of the diagnostic code in IB IL format (e.g., overrange: status = 01, diagnostic code = 8001_{hex}). If status = 0, the measured value is valid.

Unit	Code
°C	32 (20 _{hex})
°F	33 (21 _{hex})
Ohms (Ω)	37 (25 _{hex})

Status	Code
Measured value is valid	00 _{hex}
Measured value is invalid	Other

20.3 Minimum process data value (0083_{hex}: PD Min)

Object 0083_{hex} can be used to read the minimum IN process data values.

The values are initialized after each parameterization. The highest value is assigned for the minimum process data value.

PD Min = 7FFF 7FFF 7FFF 7FFF_{hex}

On every analog conversion, the PD Min value is compared with the current measured values and overwritten if necessary.

0083 _{hex} : Minimum process data value (read)			
Subindex	Data type	Length in bytes	Meaning
0	Array of INT16	4 * 2	Read all elements
1	INT16	2	Minimum process data value channel 1
:	:	:	:
4	INT16	2	Minimum process data value channel 4

20.4 Maximum process data value (0084_{hex}: PD Max)

Object 0084_{hex} can be used to read the maximum IN process data values.

The values are initialized after each parameterization. The lowest value is assigned for the maximum process data value.

PD Max = 8000 8000 8000 8000_{hex}

On every analog conversion, the PD Max value is compared with the current measured values and overwritten if necessary.

0084 _{hex} : Maximum process data value (read)			
Subindex	Data type	Length in bytes	Meaning
0	Array of INT16	4 * 2	Read all elements
1	INT16	2	Maximum process data value channel 1
:	:	:	:
4	INT16	2	Maximum process data value channel 4

20.5 Channel Scout (0090_{hex})

This object is used to quickly find a channel.

0090 _{hex} : Channel Scout (read, write)					
Subindex	Data type	Length in bytes	Meaning	Contents	
0	Var	1	Channel Scout	0	Disable all channel scout processes
				1 ... 4	Green LED of the channel is flashing at 0.5 Hz (1 second ON, 1 second OFF)

The function is terminated automatically after five minutes if you do not deactivate the Channel Scout processes. The flashing overrides all diagnostic messages of the selected channel. When a channel is parameterized, the Channel Scout function is aborted.

- 0 Disable all channel scout processes
- 1 ... 4 Green LED of the channel is flashing at 0.5 Hz (1 second ON, 1 second OFF)

21 Parameterization example

A different parameterization is selected for every channel. The data format is the IB IL format.

Channel	Connection method (wire)	Filter	R0	Resolution	Sensor type
1	3-conductor	120 ms	100 Ω	0.1 °C	Pt 100 DIN
2	2-conductor	40 ms	not relevant	1 Ω	Linear R 0 Ω ... 5 k Ω
3	4-conductor	120 ms	1000 Ω	0.1 °C	Ni 1000 DIN (= Ni DIN)
4	2-conductor	120 ms	not relevant	0.1 °C	Cu 10

The individual parameterization words are combined in accordance with the modular principle.

Channel	Parameter word (hex)	Parameter word (bin)															
		15	14	13	12	11	10	9	8	7	6	5	4	3	2	1	0
		Conductor		Filter		R0				Resolution		0	0	Sensor type			
1	0000	0	0	0	0	0	0	0	0	0	0	0	0	0	0	0	0
2	700E	0	1	1	1	0	0	0	0	0	0	0	0	1	1	1	0
3	8C02	1	0	0	0	1	1	0	0	0	0	0	0	0	0	1	0
4	4044	0	1	0	0	0	0	0	0	0	1	0	0	0	1	0	0

This results in the following parameter table:

Element	Meaning	Value (hex)
1	Parameterization of channel 1	0000
2	Parameterization of channel 2	700E
3	Parameterization of channel 3	8C02
4	Parameterization of channel 4	4044
5	Data format, system bits	0000
6	Reserved	0000

22 Device descriptions

The device is described in the device description files. These files are available for download at www.boschrexroth.com/electrics in the download area of the bus coupler used.

23 Measuring errors caused by connecting cables for sensors with 2-conductor connection

Diagram 1

Fig. 8 Systematic temperature measuring error ΔT depending on the cable length l

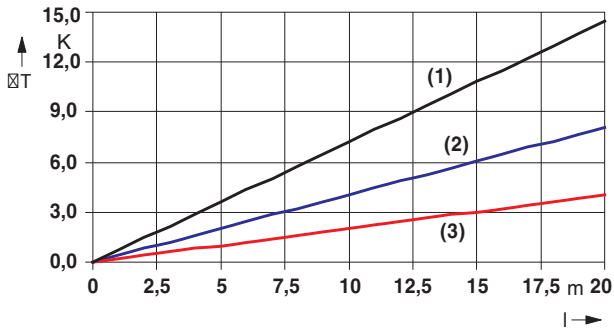

Curves depending on cable cross section A

- 1 Temperature measuring error for $A = 0.14 \text{ mm}^2$
 - 2 Temperature measuring error for $A = 0.25 \text{ mm}^2$
 - 3 Temperature measuring error for $A = 0.50 \text{ mm}^2$
- (Measuring error valid for: copper cable $\chi = 57 \text{ m}/\Omega\text{mm}^2$, $T_A = 25^\circ\text{C}$ and Pt 100 sensor)

Diagram 2

Fig. 9 Systematic temperature measuring error ΔT depending on the cable cross section A

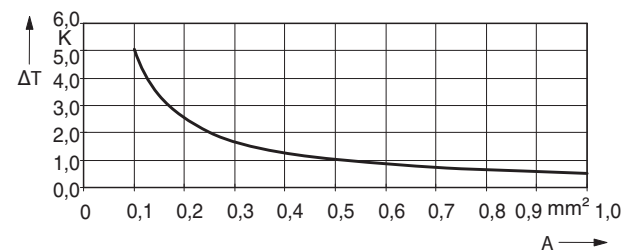

(Measuring error valid for: copper cable $\chi = 57 \text{ m}/\Omega\text{mm}^2$, $T_A = 25^\circ\text{C}$, $l = 5 \text{ m}$, and Pt 100 sensor)

Diagram 3

Fig. 10 Systematic temperature measuring error ΔT depending on the cable temperature T

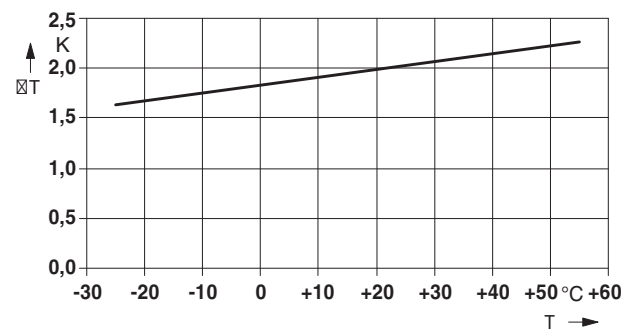

(Measuring error valid for: copper cable $\chi = 57 \text{ m}/\Omega\text{mm}^2$, $T_A = 25^\circ\text{C}$, $l = 5 \text{ m}$, $A = 0.25 \text{ mm}^2$, and Pt 100 sensor)

Conclusion

All diagrams show that the increase in cable resistance causes the measuring error.

A considerable improvement is made when Pt 1000 sensors are used. Due to the 10-fold higher temperature coefficient α ($\alpha = 0.385 \text{ } \Omega/\text{K}$ for Pt 100 to $\alpha = 3.85 \text{ } \Omega/\text{K}$ for Pt 1000) the effect of the cable resistance on the measurement is decreased by factor 10. All errors in the diagrams above would be reduced by factor 10.

Diagram 1 clearly shows the effect of the cable length on the cable resistance and therefore on the measuring error. The solution is to use the shortest possible sensor cables.

Diagram 2 shows the influence of the cable diameter on the cable resistance. It can be seen that cables with a diameter of less than 0.5 mm^2 cause the error to increase exponentially.

Diagram 3 shows the influence of the ambient temperature on the cable resistance. This parameter is of minor importance and can hardly be influenced. It is mentioned here only for the sake of completeness.

The formula for calculating the cable resistance is as follows:

$$R_L = R_{L20} \times \left(1 + 0,0039 \frac{1}{K} \times (T - 20^\circ\text{C}) \right)$$

$$R_L = \frac{l}{\chi \times A} \times \left(1 + 0,0039 \frac{1}{K} \times (T - 20^\circ\text{C}) \right)$$

Where:

R_L	Cable resistance in Ω
R_{L20}	Cable resistance at 20°C in Ω
l	Cable length in m
χ	Specific electrical resistance of copper in $\text{m}/\Omega\text{mm}^2$
A	Cable cross section in mm^2
0.0039 1/K	Temperature coefficient for copper (percentage purity of 99.9%)
T	Ambient temperature (cable temperature) in $^\circ\text{C}$

Since there are two cable resistances in the measuring system (forward and return), the value must be doubled. The absolute measuring error in Kelvin [K] is provided for platinum detectors according to DIN using the average temperature coefficient χ ($\chi = 0.385 \text{ } \Omega/\text{K}$ for Pt 100; $\chi = 3.85 \text{ } \Omega/\text{K}$ for Pt 1000).

24 Calculation examples

24.1 Calculation base for the following examples

For the measuring temperature in question, use the measuring range $-200^{\circ}\text{C} \dots +200^{\circ}\text{C}$.

For the tolerances, go to section "Tolerances in 4-conductor technology at 25°C ".

Extract from the table:

No.	Sensor type	Measuring range		Absolute tolerance		Relative tolerance (with reference to MRFV)	
		Lower limit	Upper limit	Typical	Maximum	Typical	Maximum
1	Pt 100 DIN and SAMA	-200°C	$+200^{\circ}\text{C}$	$\pm 0.05\text{ K}$	$\pm 0.25\text{ K}$	$\pm 0.03\%$	$\pm 0.13\%$

For the drift, go to section "Tolerance and temperature response (drift behavior) for 4-conductor connection".

Extract from the table:

Tolerance and temperature response at $T_A = -25^{\circ}\text{C} \dots +60^{\circ}\text{C}$				
Sensor type	Measuring range		Drift	
	Lower limit	Upper limit	Typical	Maximum
Pt 100 DIN and SAMA	-200°C	$+200^{\circ}\text{C}$	$\pm 3\text{ ppm/K}$	$\pm 18\text{ ppm/K}$

24.2 Typical temperature behavior

Task setting:

Temperatures of up to +45°C are achieved in the control cabinet.

1. What typical drift values of the measuring inputs are to be expected for temperature measurement with a Pt100 sensor using 4-conductor technology at a measuring temperature of +180°C for this device?
2. What typical measuring tolerance is to be expected at +45°C?

Calculation:

The temperature difference is calculated using the formula (1):

$$\Delta T_U = T_S - 25 \text{ °C} \quad (1)$$

Where:

ΔT_U	Temperature difference (difference between current switch cabinet temperature and reference temperature of +25°C)
T_S	Current temperature in the switch cabinet
Value for this example:	
T_S	= 45 °C

According to formula (1)

$$\begin{aligned} \Delta T_U &= T_S - 25 \text{ °C} \\ &= 45 \text{ °C} - 25 \text{ °C} \\ &= 20 \text{ K} \end{aligned}$$

The temperature drift of the Pt 100 sensor is calculated according to formula (2):

$$T_{\text{Drift}} = \Delta T_A \times T_K \times T_M \quad (2)$$

Where:

T_{Drift}	Temperature drift of the Pt 100 measuring input
ΔT_U	Temperature difference; from formula (1)
T_K	Temperature coefficient
T_M	Measuring range final value
Values for this example:	
ΔT_U	= 20 K
T_K	= ±3 ppm/K (typical drift)
T_M	= 200 °C

According to formula (2)

$$\begin{aligned} T_{\text{Drift}} &= \Delta T_A \times T_K \times T_M \\ &= 20 \text{ K} \times \pm 3 \text{ ppm/K} \times 200 \text{ °C} \\ &= 20 \times \pm 3 \times 10^{-6} \times 200 \text{ °C} \\ &= \pm 0.012 \text{ K} \\ T_{\text{Drift}} &= \pm 0.01 \text{ K} \end{aligned}$$

Solution:

Under these marginal conditions, a typical temperature drift of ±0.01 K is to be expected.

Calculation of the typical measuring tolerance:

The measuring tolerance is calculated using the formula (3):

$$\Delta T_{\text{Tot}} = \Delta T_{25} + T_{\text{Drift}} \quad (3)$$

Where:

ΔT_{Tot}	Total tolerance
ΔT_{25}	Typical tolerance at 25°C
T_{Drift}	Drift at 45°C; from formula (2)
Values for this example:	
ΔT_{25}	= ±0.05 K (typical absolute tolerance)
T_{Drift}	= ±0.01 K

According to formula (3)

$$\begin{aligned} \Delta T_{\text{Tot}} &= \Delta T_{25} + T_{\text{Drift}} \\ &= \pm 0.05 \text{ K} + \pm 0.01 \text{ K} \\ \Delta T_{\text{Tot}} &= \pm 0.06 \text{ K} \end{aligned}$$

Solution:

At an ambient temperature of +45°C, a typical measuring tolerance of ±0.06 K is to be expected.

24.3 Maximum temperature behavior (worst case)

Task setting:

Temperatures of up to +40°C are achieved in the control cabinet.

What typical drift values of the measuring inputs are to be expected for temperature measurement with a Pt100 sensor using 4-conductor technology at a measuring temperature of +200°C for this device?

Calculation:

The measuring tolerance is calculated using the formula (3):

$$\Delta T_{\text{Tot}} = \Delta T_{25} + T_{\text{Drift}} \quad (3)$$

Values for this example:

$$\begin{aligned} \Delta T_{25} &= \pm 0.25 \text{ K (maximum absolute tolerance)} \\ T_{\text{Drift}} &\text{ Must be calculated} \end{aligned}$$

To calculate the drift, proceed as described in the example for the typical temperature response.

The temperature difference is calculated using the formula (1):

$$\Delta T_U = T_S - 25 \text{ °C} \quad (1)$$

Value for this example:

$$T_S = 40 \text{ °C}$$

According to formula (1)

$$\begin{aligned} \Delta T_U &= T_S - 25 \text{ °C} \\ &= 40 \text{ °C} - 25 \text{ °C} \\ &= 15 \text{ K} \end{aligned}$$

The maximum temperature drift of the Pt 100 sensor is calculated according to formula (2):

$$T_{\text{Drift}} = \Delta T_A \times T_K \times T_M \quad (2)$$

Values for this example:

$$\begin{aligned} \Delta T_U &= 15 \text{ K} \\ T_K &= \pm 18 \text{ ppm/K (maximum drift)} \\ T_M &= 200 \text{ °C} \end{aligned}$$

According to formula (2)

$$\begin{aligned} T_{\text{Drift}} &= \Delta T_A \times T_K \times T_M \\ &= 15 \text{ K} \times \pm 18 \text{ ppm/K} \times 200 \text{ °C} \\ &= 15 \times \pm 18 \times 10^{-6} \times 200 \text{ °C} \\ &= \pm 0.054 \text{ K} \\ T_{\text{Drift}} &= \pm 0.05 \text{ K} \end{aligned}$$

The measuring tolerance is calculated using the formula (3):

According to formula (3)

$$\begin{aligned} \Delta T_{\text{Tot}} &= \Delta T_{25} + T_{\text{Drift}} \\ &= \pm 0.25 \text{ K} + \pm 0.05 \text{ K} \\ \Delta T_{\text{Tot}} &= \pm 0.30 \text{ K} \end{aligned}$$

Solution:

At an ambient temperature of +40°C, a maximum worst-case measuring tolerance of ±0.3 K is to be expected.