

# Roller rail systems

## High Precision RSHP

Roller runner blocks, roller guide rails, accessories

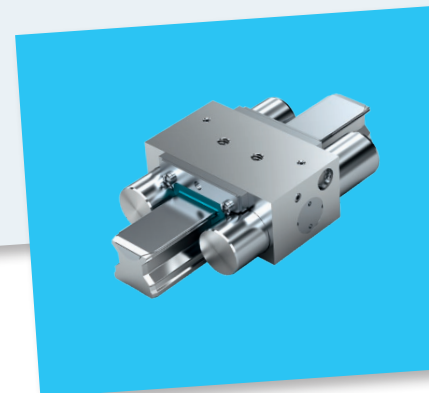
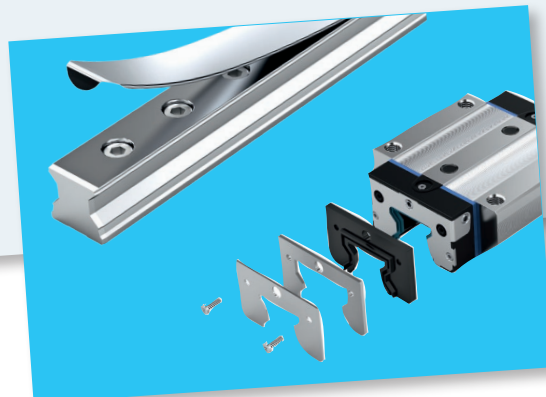
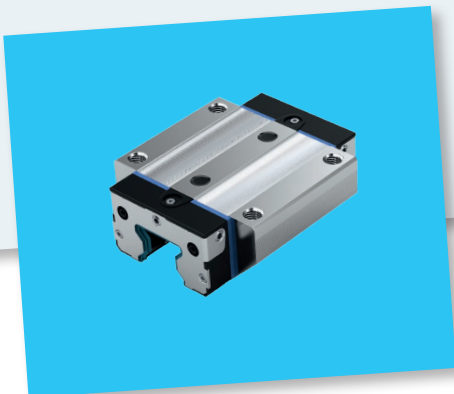
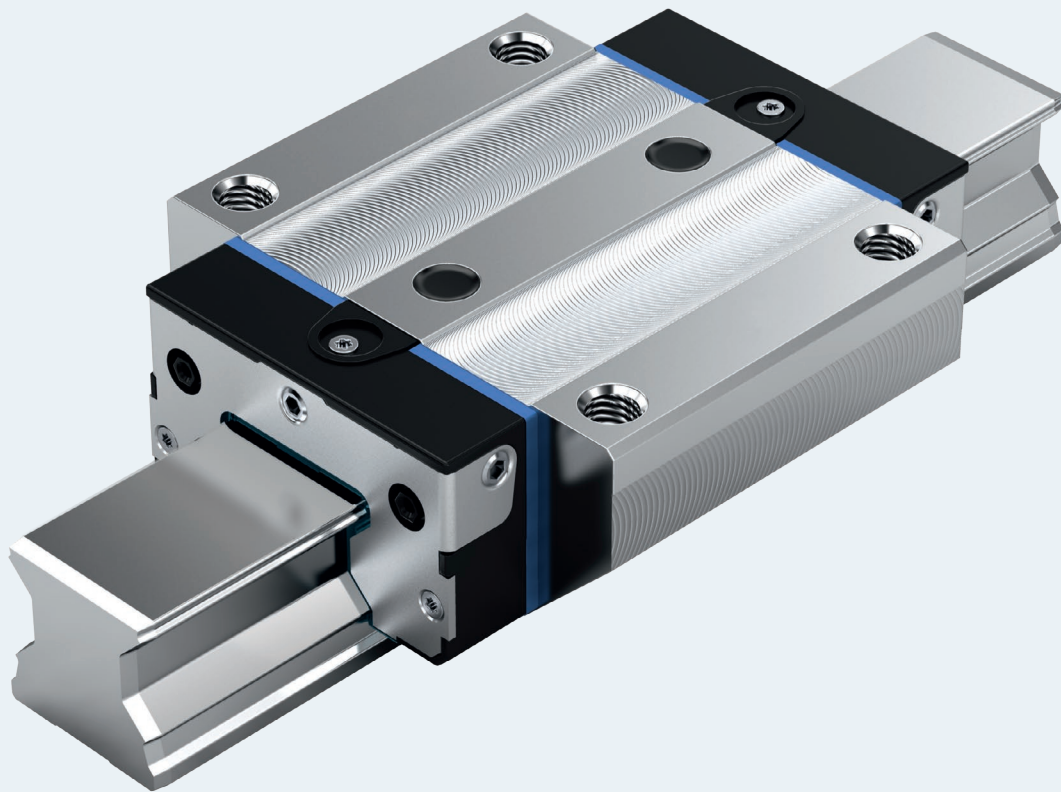

<b>General product description</b>	<b>4</b>	<b>Standard roller runner block Resist CR</b>	<b>62</b>
New features at a glance	4	Product description, Roller runner block Resist CR	62
Product description	5		
Formats	6	<b>Standard roller guide rails made of steel</b>	<b>64</b>
Structure and materials	7	Product description	64
General notes	8	Overview of formats and models	64
Intended use	8	SNS/SNO with cover strip and strip clamps R1805 .3. ./R1805 .B. ..	66
Misuse	8	SNS/SNO with cover strip and protective caps R1805 .6. ./R1805 .D. ..	68
General safety instructions	8	SNS/SNO for cover strip R1805 .2. 3./R1805 .A. 3.	70
Directives and standards	9	SNS/SNO with plastic caps R1805 .5. 3./R1805 .C. 3.	72
Selection of a linear guide according to DIN 637	10	SNS/SNO with steel caps R1806 .5. 3./R1806 .C. 3.	74
Product description of high-precision version	11	SNS for bolting from below R1807 .0. 3.	76
Product overview, roller runner blocks with load capacities	18		
Product overview of roller guide rails with lengths	19		
General technical data and calculations	20		
Seals	22		
<b>Selection criteria</b>	<b>30</b>	<b>Roller guide rails standard Resist CR</b>	<b>78</b>
Rigidity of standard roller runner block FNS	30	Product description roller guide rails Resist CR, matte-silver hard chrome plated	78
Rigidity of standard roller runner block FLS	32	Product description roller guide rails Resist CR II, black hard chrome plated	80
Rigidity of standard roller runner block SNS/SNH	34		
Rigidity of standard roller runner block SLS/SLH	36		
Rigidity of heavy-duty roller runner blocks FNS	38		
Rigidity of heavy-duty roller runner blocks FLS	39	<b>NEW: Roller guide rail with temperature control</b>	<b>82</b>
Rigidity of heavy-duty roller runner blocks FXS	40	Roller guide rails with temperature control, product description	82
Accuracy classes	42		
Preload	46		
<b>Roller runner block made of steel RSHP</b>	<b>48</b>	<b>Heavy-duty roller rail system</b>	<b>84</b>
Product description	48	Product description	84
FNS – flanged, normal, standard height R1851 ... 2.	50	Heavy-duty roller runner blocks FXS - Flange, extra long, standard height, made of steel R1854 ... 1.	86
FLS – flanged, long, standard height – R1853 ... 2.	52	Heavy-duty roller runner blocks FNS - flanged, normal, standard height, made of steel R1861 ... 1. / Resist CR R1861 ... 6.	88
SNS – slimline, normal, standard height – R1822 ... 2.	54	Heavy-duty roller runner blocks FLS - flanged, long, standard height, made of steel R1863 ... 1. / Resist CR R1863 ... 6.	90
SLS – slimline, long, standard height – R1823 ... 2.	56	Heavy-duty roller guide rail SNS with cover strip made of steel R1835 .6. .. / Resist CR R1865 .6. ..	92
SNH – slimline, normal, high – R1821 ... 2.	58	Heavy-duty roller guide rails SNS with steel caps R1836 .5. ..	94
SLH – slimline, long, high – R1824 ... 2.	60		

<b>Accessories for Roller runner block RSHP</b>	<b>96</b>	Hydraulic clamping units	
Overview of Accessories for Roller runner blocks	96	product description	136
Cover plate wiper	97	Hydraulic clamping units KWH	138
FKM seal	98	FLS	138
FKM seal set	99	SLS	139
Front lube units	100	SLH	140
Bellows	104	Pneumatic clamping and braking units,	
Lubrication plate for size 25	109	product description	142
Lube fittings	110	Pneumatic clamping and braking units MBPS	144
		Pneumatic clamping and braking units UBPS	146
		Product description	
<b>Accessories for heavy-duty Roller runner blocks</b>	<b>113</b>	pneumatic clamping units	148
Overview of Accessories for heavy-duty Roller runner blocks	113	Pneumatic clamping units MK	150
Cover plate wiper	114	Pneumatic clamping units MKS	152
FKM seal	115	Manual clamping units, spacer plates,	
FKM seal set	116	product description	154
		Manual clamping unit HK	156
		Spacer plate for MK, MKS, HK	157
		Clamping and braking units,	
		safety instructions	158
<b>Accessories for roller guide rails</b>	<b>117</b>	<b>Mounting</b>	<b>160</b>
Overview of Accessories for roller guide rails	117	General instructions for mounting	160
Mounting runner block	118	Fastener	172
Cover strip	119		
Mounting device for cover strip	121	<b>Lubrication</b>	<b>180</b>
Retainers for cover strip	122	Note on lubrication	180
Plastic caps	123	Lubrication RSHP	182
Steel caps	124	Lubrication for heavy-duty roller rail system	193
Mounting tool for steel caps	124	Maintenance	204
Adjusting shafts	125		
V-guide	126	<b>Further information</b>	<b>205</b>
		Further information	205
<b>Spare parts</b>	<b>127</b>		
Front seal	127		
End cap with front seal set	128		
Cardboard box opener	128		
Transport lock	129		
<b>Clamping and braking units</b>	<b>130</b>		
Clamping and braking units,			
product overview	130		
Product description hydraulic clamping and braking units	132		
Hydraulic clamping and braking units KBH	134		
FLS	134		
SLH	135		

# New features at a glance

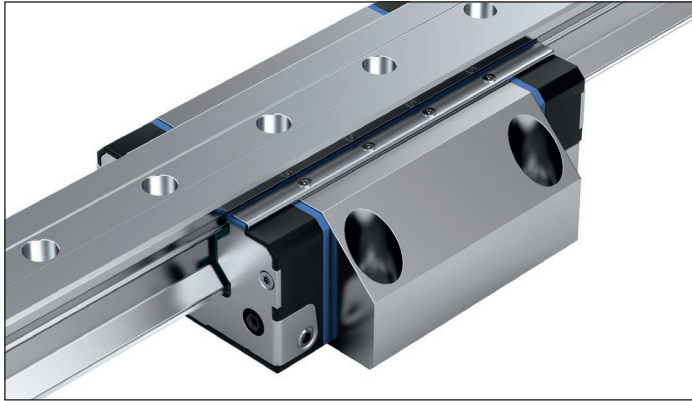

**Longitudinal seal AS**

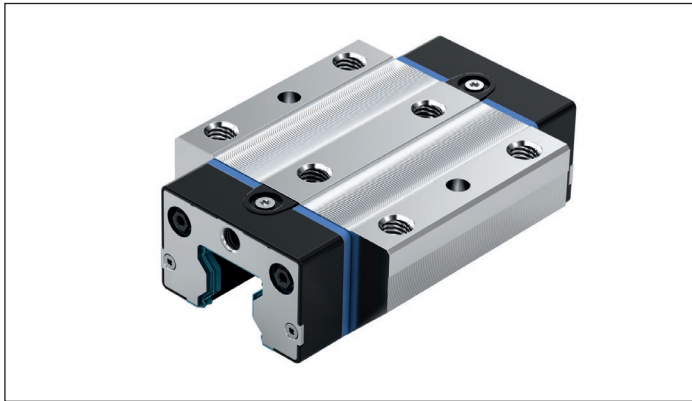

**Size 25 RSHP available**

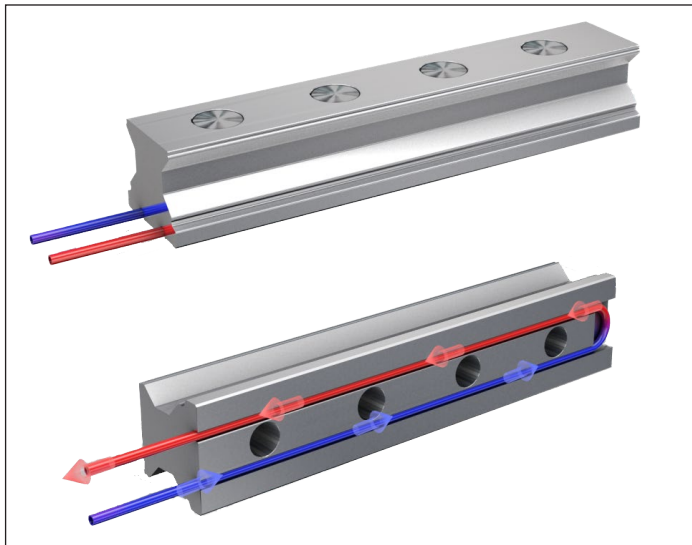

**Roller guide rail with temperature control**

# Product description

Rexroth Roller rail systems have been developed in particular for machine tools, industrial robots, general machine building etc., which require the compact, roller-mounted longitudinal guides in various accuracy classes with a very high load-bearing capacity and high rigidity.

## Characteristic features

Standard Roller Rail Systems are suitable for all typical applications. The extremely compact assembly units in many common sizes have the same high load capacity in all four main directions of loading.

Standard roller runner blocks are also available for special installation, usage and environmental conditions of use. Suitable heavy-duty roller rail systems are available for heavy machine construction.

## Further highlights

- ▶ Uniform roller guide rails with and without cover strips allow limitless interchangeability across all roller runner block variants
- ▶ Lube nipples possible on all sides for easy maintenance
- ▶ Low lubrication quantities thanks to innovative channel design
- ▶ Quiet running thanks to optimally designed roller return and guideway
- ▶ Attachments on the roller runner block can be mounted from above and below
- ▶ Maximum rigidity in all directions of loading due to additional screw connections on two bores in the center of the roller runner block

## Complete guide units can also be designed by combining interchangeable elements from stock ...

Roller guide rails and roller runner blocks are manufactured by Rexroth with such high precision that each element is fully interchangeable. As a result they can be combined as required.

Each element can be individually planned and separately stocked. Both sides of the roller guide rail can be used as reference edges.

Accessories can be screwed down to the end-face of the roller runner block.

- ▶ High torque load capacity
- ▶ Lowest elastic deflection and greatest precision in the travel performance due to the further optimized entry-zone geometry and high number of rollers (formulated in an enhanced manner)
- ▶ The roller runner block is simply slid onto the rail with the transport lock
- ▶ Integrated all-round sealing as standard

## Optional

- ▶ Low-corrosion roller runner blocks and roller guide rails Resist CR, hard chrome plated, available in accuracy class H and in accuracy classes P and SP on request.

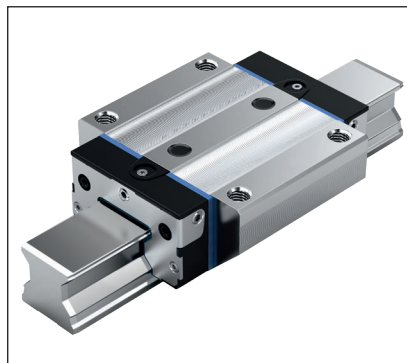

## Formats

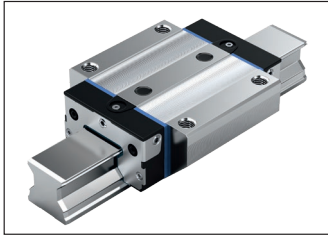

**FNS – Flanged, normal, standard height**

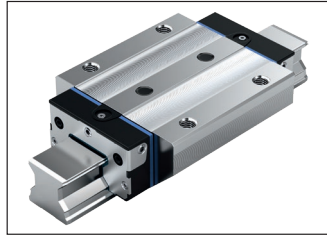

**FLS – Flanged, long, standard height**

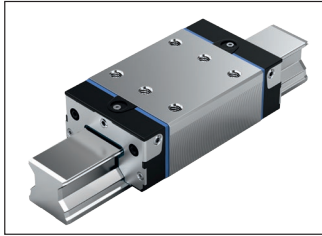

**SNS – Slimline, normal, standard height**

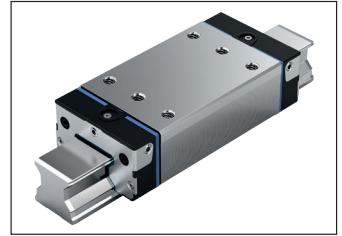

**SLS – Slimline, long, standard height**

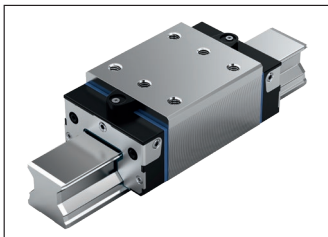

**SNH – Slimline, normal, high**

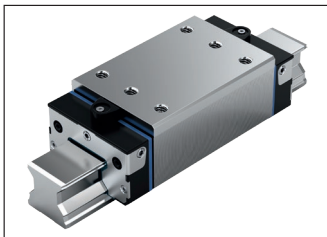

**SLH – Slimline, long, high**

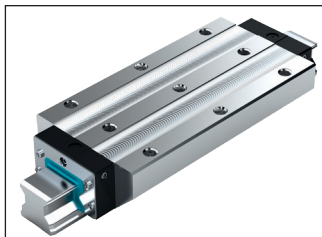

**FXS – Flanged, extra long, standard height**

### Definition of the format of roller runner blocks

Criterion	Designation	Code (example)		
		F	N	S
Width	Flange (F)	F		
	Slimline (S)	S		
Length	Normal (N)		N	
	Long (L)		L	
	Extra long (X)		X	
Height	Standard height (S)			S
	High (H)			H

### Format with flange -

Design for bolting from above and below

### Slimline format -

Design for bolting from above



### Roller guide rail SNS with the proven cover strip for covering the fastening bores

- ▶ One cover for all bore holes saves time and costs
- ▶ Made of stainless spring steel as per DIN EN 10088
- ▶ Easy and safe during mounting
- ▶ Clip on and secure

### Definition of the format of roller guide rails

Criterion	Designation	Code (example)		
		S	N	S
Width	Slimline (S)	S		
Length	Normal (N)		N	
Height	Standard height (S)			S
	Without groove (O)			O

# Structure and materials

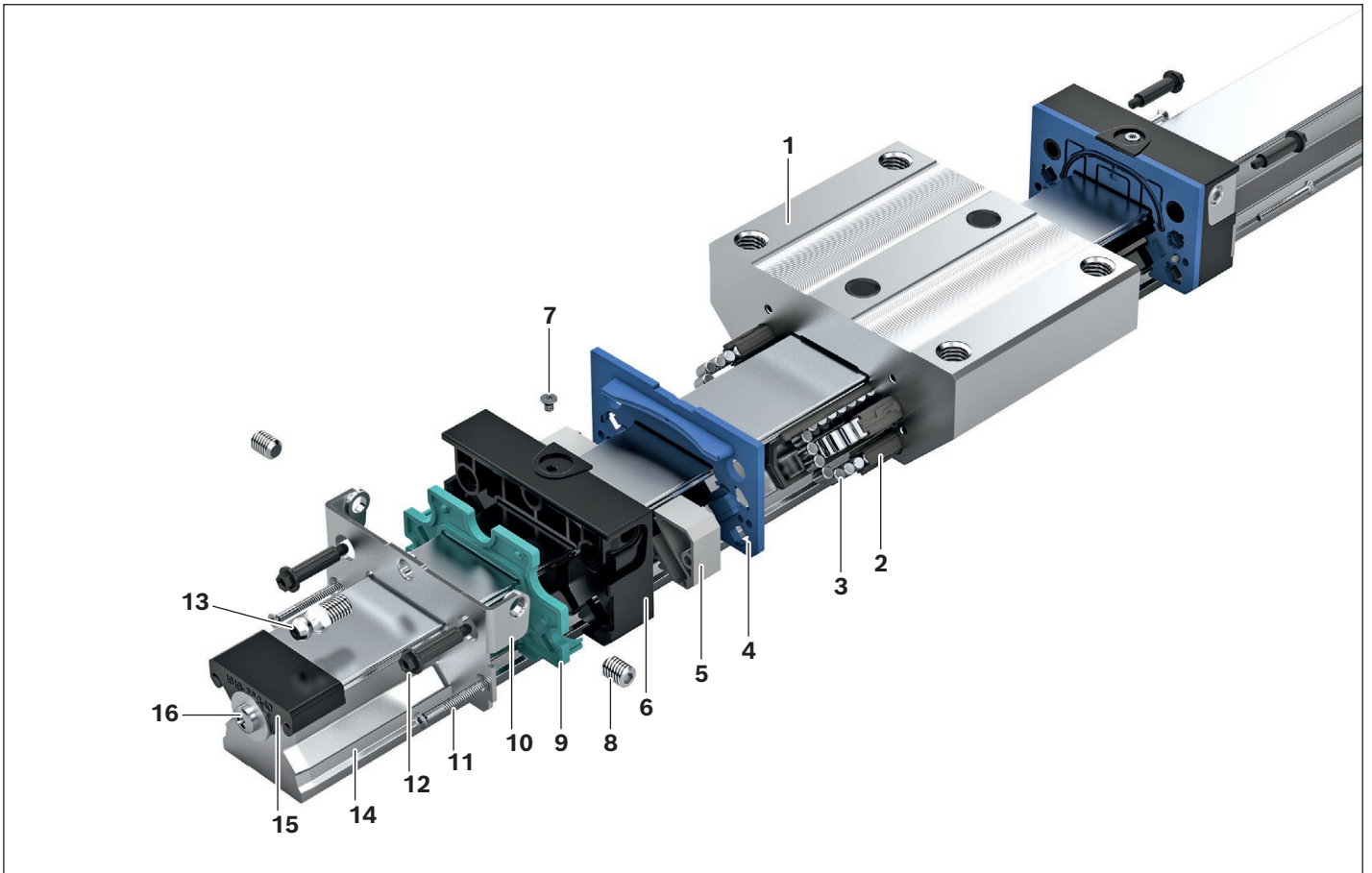

## Components and their materials

Position	Component	Roller runner block		Roller guide rails	
		Steel	Resist CR	Steel	Resist CR / CR II
1	Roller runner block	Heat-treated steel	Hard chrome-plated heat-treated steel		
2	Return channel	Plastic	Plastic		
3	Cylinder rollers	Anti-friction bearing steel	Anti-friction bearing steel		
4	Diversion plate	Plastic	Plastic		
5	Diversion component	Plastic	Plastic		
6	Roller guide	Plastic	Plastic		
7	Screw plug	Carbon steel	Carbon steel		
8	Set screw	Corrosion resistant steel	Corrosion resistant steel		
9	Sealing plate	Plastic	Plastic		
10	Threaded plate	Corrosion resistant steel	Corrosion resistant steel		
11	Oval-head screws	Corrosion resistant steel	Corrosion resistant steel		
12	hexagonal screws	Carbon steel	Carbon steel		
13	Lube nipple	Carbon steel	Carbon steel		
14	Roller guide rail			Heat-treated steel	Hard chrome-plated heat-treated steel
15	Protective cap			Plastic	Plastic
16	Screw/washer			Corrosion resistant steel	Corrosion resistant steel

## General notes

- ▶ Combinations of different accuracy classes

When combining roller guide rails and roller runner blocks of varying accuracy classes, the tolerances for the dimensions H and A3 change. See "Accuracy classes and their tolerances."

## Intended use

- ▶ The Roller Rail Systems are linear guideways capable of absorbing forces from all transverse directions and moments about all axes. The Roller Rail System is intended exclusively for guiding and positioning tasks when installed in a machine.
- ▶ The product is intended exclusively for professional use and not for private use.
- ▶ Use for the intended purpose also includes the requirement that users must have read and understood the related documentation completely, in particular the "Safety instructions".

## Misuse

Use of the product in any other way than as described under "Intended use" is considered to be misuse and is therefore not permitted. If unsuitable products are installed or used in safety-critical applications, this may lead to uncontrolled operating statuses in the application which can cause personal injury and/or damage to property.

The product may only be used in safety-critical applications if this use has been expressly specified and permitted in the product documentation.

Bosch Rexroth AG will not accept any liability for injury or damage caused by misuse of the product. The risks associated with any misuse of the product shall be borne by the user alone.

Misuse of the product includes:

- ▶ The transport of persons

## General safety instructions

- ▶ The safety rules and regulations of the country in which the product is used must be observed.
- ▶ All current and applicable accident prevention and environmental regulations must be adhered to.
- ▶ The product may only be used when it is in technically perfect condition.
- ▶ The technical data and environmental conditions stated in the product documentation must be complied with.
- ▶ The product must not be put into service until it has been verified that the final product (for example a machine or system) into which the product has been installed complies with the country-specific requirements, safety regulations and standards for the application.
- ▶ Rexroth Roller Rail Systems may not be used in zones with potentially explosive atmospheres as defined in the ATEX directive 94/9/EC.
- ▶ Rexroth Roller rail systems must never be altered or modified. The user may only perform the work described in the "Quick User Guide" or the "Mounting instructions for Roller Rail System".
- ▶ The product is never allowed to be disassembled.
- ▶ At high travel speeds a certain amount of noise is caused by the product. If necessary, appropriate measures should be taken to protect hearing.
- ▶ The special safety requirements for specific sectors (e.g. crane construction, theaters, food technology) set forth in laws, directives and standards must be complied with.
- ▶ In all cases, the provisions of the following standard should be noted and followed. DIN 637, Safety regulations for dimensioning and operation of Profiled Rail Systems with recirculating rolling elements.

## Directives and standards

Rexroth Roller rail systems RSHP guides are designed for reliability and high precision in dynamic, linear applications. The machine tool industry and other sectors must observe a series of standards and directives. These requirements can vary significantly worldwide. It is therefore essential to understand the legislation and standards that apply in each particular region.

### **DIN EN ISO 12100**

This standard describes the safety of machinery – general principles for design, risk assessment and risk reduction. It gives a general overview and contains a guide to the major developments governing machines and their intended use.

### **Directive 2006/42/EC**

The European Machinery Directive describes the basic safety and health requirements for the structural design and manufacture of machinery. The manufacturer of a machine or his authorized representative has a duty to ensure that a risk assessment has been performed in order to determine the health and safety requirements which have to be fulfilled for that machine. The machine must be designed and built taking into consideration the results of the risk assessment.

### **Directive 2001/95/EC**

This directive covers general safety requirements for any product placed on the market and intended for consumers, or likely to be used by consumers under reasonably foreseeable conditions, including products that are made available to consumers in the context of service provision for use by them

### **Directive 1999/34/EC**

This directive concerns the liability for defective products and applies to industrially manufactured movable objects, irrespective of whether or not they have been incorporated into another movable or immovable object.

### **REGULATION (EC) No. 1907/2006 (REACH)**

This regulation relates to restrictions on the marketing and use of certain dangerous substances and preparations. "Substances" means chemical elements and their compounds as they occur in the natural state or as produced by industry. "Preparations" means mixtures or solutions composed of two or more substances.

# Selection of a linear guide according to DIN 637

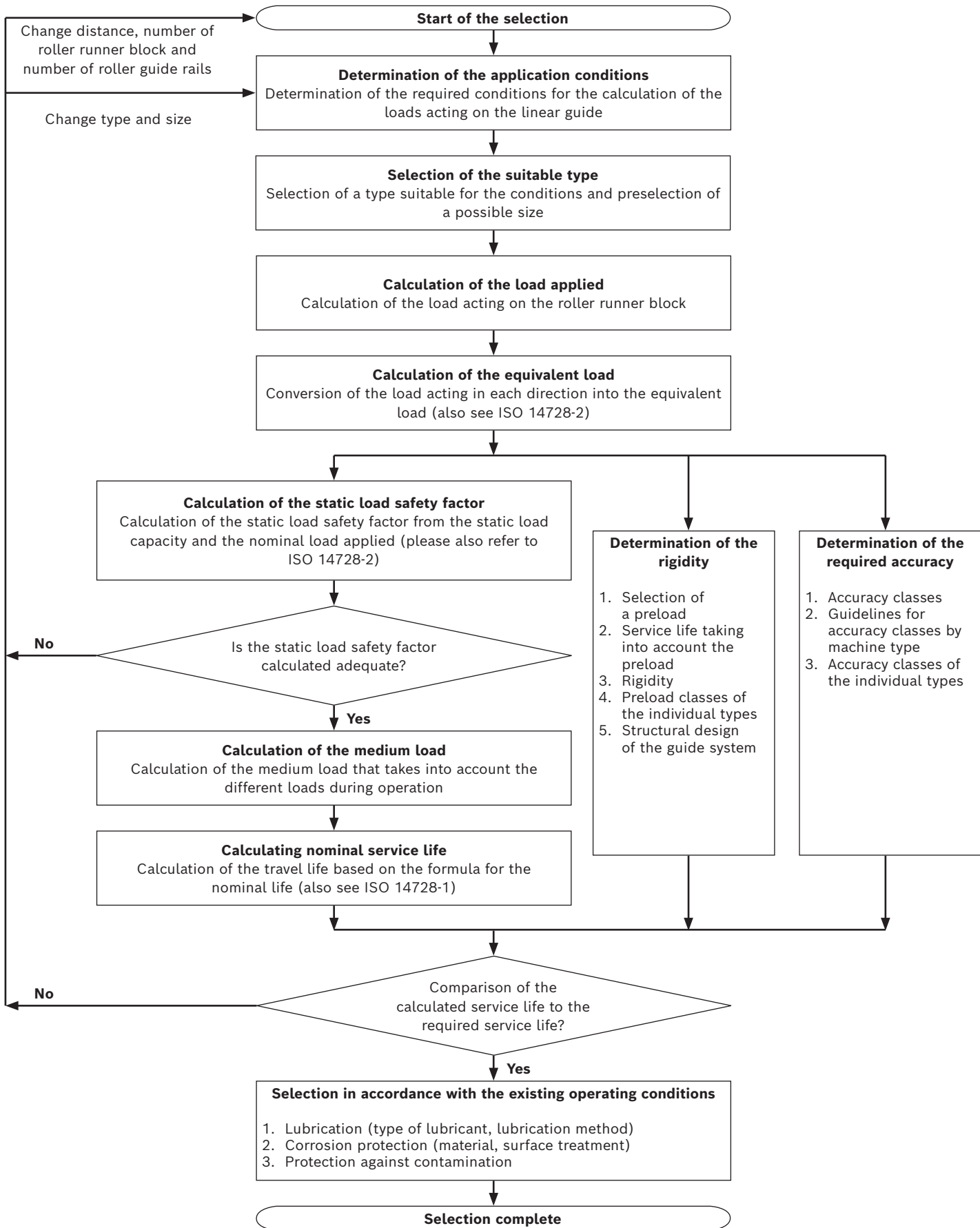

# Product description of high-precision version

## Formats of High-Precision Roller runner blocks

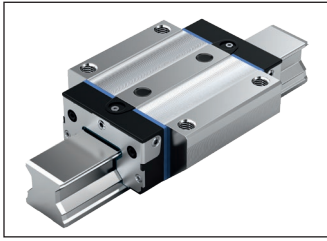

**FNS – Flanged, normal, standard height**

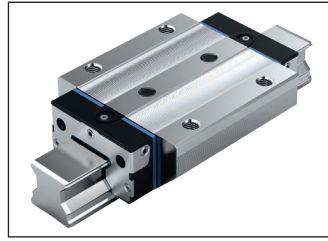

**FLS – Flanged, long, standard height**

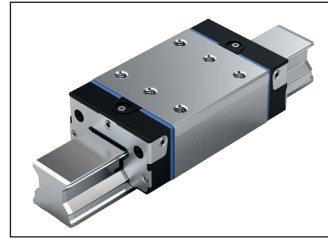

**SNS – Slimline, normal, standard height**

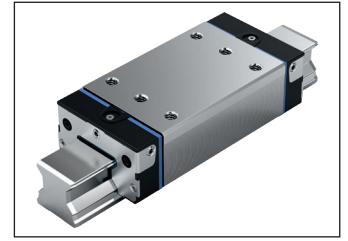

**SLS – Slimline, long, standard height**

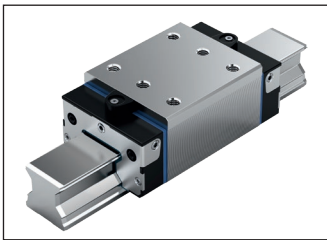

**SNH – Slimline, normal, high**

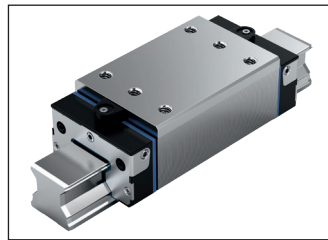

**SLH – Slimline, long, high**

## Application examples

Rexroth High-Precision roller runner blocks are particularly suited for the following applications:

### Grinding

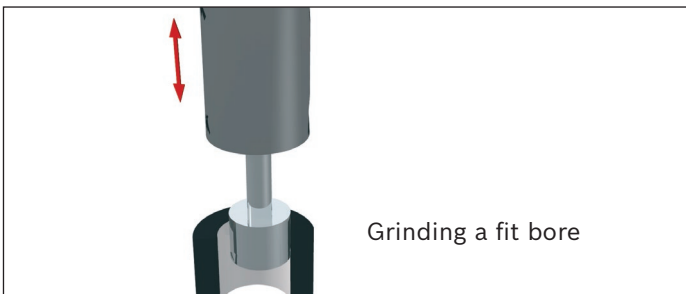

Grinding a fit bore

Internal cylindrical grinding

### Milling



Milling a mold insert

Hard milling

### Turning

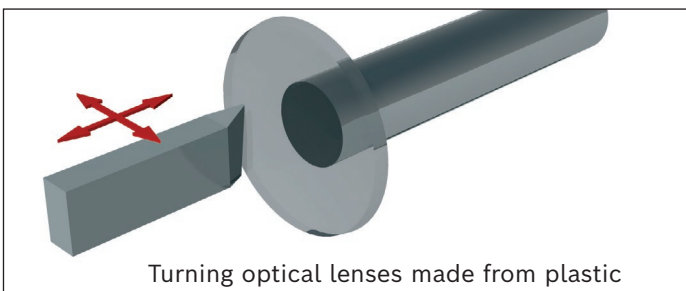

Turning optical lenses made from plastic

High-precision turning

These are only a few examples. Naturally, other applications can be realized. Feel free to ask any questions that you may have. We have an appropriate solution.

# Product description of high-precision version

## Highlights

- ▶ Improved travel accuracy
- ▶ Significantly reduced frictional oscillations and low friction force level, particularly under external load
- ▶ Maximum precision
- ▶ Selected qualities
- ▶ The minimum amount preservation minimizes the impairment of the environment by the preservative agent
- ▶ Optimized entry zone increases the travel accuracy

## Compare:

### Conventional roller runner block

If the roller runner block comprises of a conventional entry zone, this may only be designed for a specific load point.

#### Entry-zone geometry for conventional roller runner block

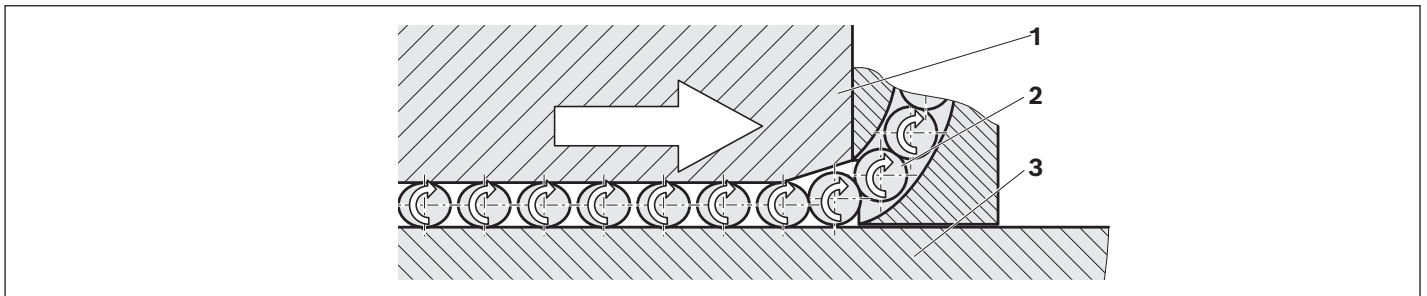

1 Roller runner block    2 Rollers    3 Roller guide rail

#### Roller entry

- ▶ The rollers are guided up to the start of the entry zone via the roller deflection.
- ▶ If the distance between the roller runner block (1) and the roller guide rail (3) is smaller than the roller diameter, the roller (2) is put under load (preload) in pulses.
- ▶ The preload is increased in the entry zone and reaches its maximum in the load bearing zone. By doing so, the roller transmits its force from the roller runner block to the roller guide rail.
- ▶ Due to the kinematic and geometric relations, a distance between the individual rollers is set.

#### Entry zone

The conventional roller runner blocks comprise of a fix entry zone. The depth of the entry zone shall be suitable for a high load, since a fault-free roller entry is to be guaranteed under very high loads, as well.

- ▶ On the one hand, as many load-bearing rollers as possible should be in the roller runner block in order to reach an ideal load-bearing capacity.  
⇒ Entry zone as short as possible
- ▶ On the other hand, the load during the entry of the rollers should be increased as slowly as possible and thus in a harmonic manner in order to reach the maximum of the geometric travel accuracy.  
⇒ Entry zone which is as flat (long) as possible

There is a conflict of aims between short and long entry zones.

## High-Precision roller runner block

### New entry-zone geometry for roller runner block in high-precision version

The roller runner block in high-precision version comprise of an innovative entry zone. This allows the rollers to enter the load-bearing zone harmonically, i.e. without any impulse loads.

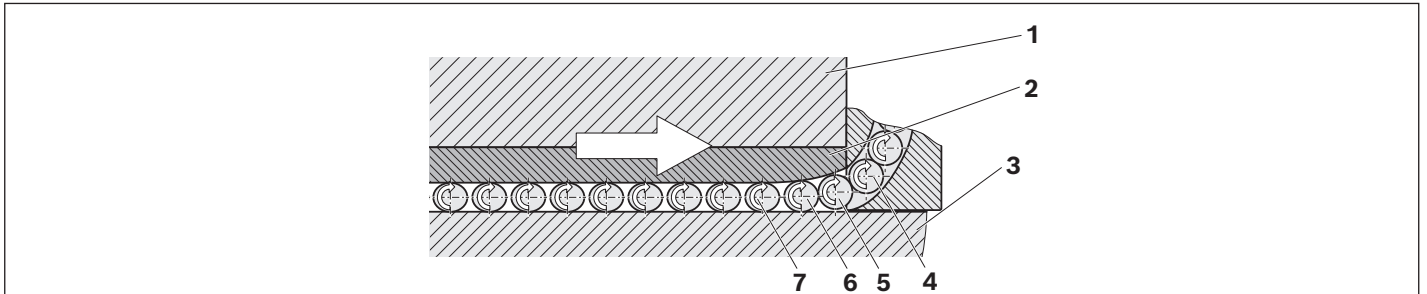

- |                              |                            |
|------------------------------|----------------------------|
| <b>1</b> Roller runner block | <b>3</b> Roller guide rail |
| <b>2</b> Steel bearing plate | <b>4 - 7</b> rollers       |

### Roller entry

- ▶ The rollers (4) are guided up to the start of the entry zone via the roller deflection.
- ▶ The roller (5) can be entered.
- ▶ If the distance between the steel load-bearing plate and the roller guide rail is smaller than the roller diameter, the roller is put under load again slowly and evenly (preload).
- ▶ The preload is increased harmonically until the rollers (7) have reached their maximum preload.

### Innovative solutions by Rexroth:

#### The optimized entry zone

The functionality of the entry zone is decisive. The steel bearing plates are manufactured with such precision that they can withstand increasing load as curvature becomes more convex. Thus, the rollers can enter particularly smoothly. The rollers thus no longer crash their way into the load-bearing zone through an oblique entry zone, rather transition smoothly on a tangential, ideally angled elastic line into the load-bearing zone.

The smooth entry of the rollers and the optimized adaptation of the entry zone to the load represent a decisive benefit of the High-Precision Roller runner blocks.

### Characteristic features

- 1** Maximum travel accuracy
- 2** Reduced friction force oscillations
- 3** The conflict of aims is resolved

## Product description of high-precision version

### Fluctuation of friction forces

#### Definition

The overall driving force of a roller runner block consist of the following components:

- 1 Roller friction
- 2 Sealing friction
- 3 Friction in the roller deflections and roller returns

In operation, the fluctuations of the friction force can be particularly disturbing.

#### These fluctuations are essentially impacted by the following effect:

The rollers need to be inserted into the loaded load-bearing zone from the load-free zone. The harmonic entry zone and the optimized roller entry are used to reduce the fluctuations to a minimum, which means that the linear drive will also be easier to control.

#### Conventional roller runner block

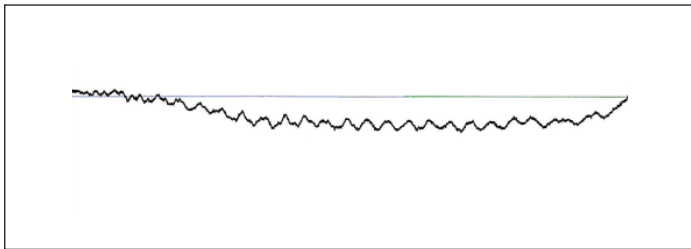

#### High-Precision roller runner block

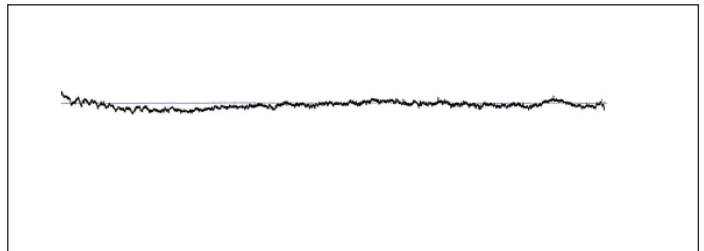

## Travel accuracy

### Definition

In an ideal case, a roller runner block moves translatively in relation to the x-axis over the roller guide rail. In practice, however, deviations occur in all six degrees of freedom. The term travel accuracy describes the deviation from this ideal line.

#### Six different degrees of freedom

- 1 Vertical offset (linear deviation in Z)
- 2 Yaw (rotary motion around Z)
- 3 Side deviation (linear deviation in Y)
- 4 Pitching (rotary motion around Y)
- 5 Translation (linear movement in X)
- 6 Rollers (rotary motion around x)

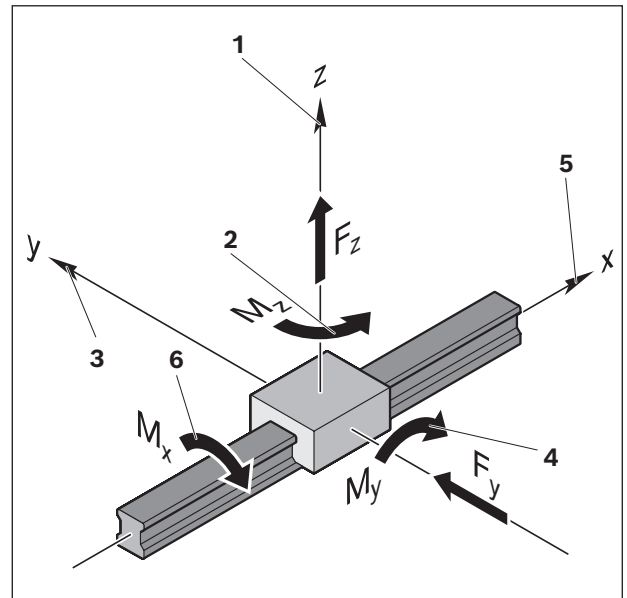

### Causes of travel inaccuracy

The travel accuracy is impacted by the following points:

1. Inaccurate mounting base on which the roller guide rail is mounted.
2. Parallelism error between the contact areas of the roller guide rail and the running tracks.
3. Elastic deformations of the roller guide rail due to the fixing screws.
4. Accuracy fluctuations caused by the rollers entering and exiting.

### Potential for optimization

ad 1.: Contact surfaces of the roller guide rail should be produced as precisely as possible (outside the scope of influence of Rexroth).

ad 2.: Any deviation should be equalized by the selection of the accuracy class of the roller guide rail.

ad 3.: Reduce the tightening torque. The tightening torque of the fastening screws has a proportional impact. A reduction of the tightening torque decreases the compressive strain of the rail material.

⇒ Lower geometric process fluctuations

**⚠ ATTENTION:** With this measure, the transferable forces and moments can be reduced.

ad 4. The optimized entry zone of Rexroth high-precision roller runner blocks reduces the accuracy fluctuations to a minimum.

Further potential for improvements:

- ▶ Use of long Roller runner blocks
- ▶ Installation of additional roller runner blocks for each roller guide rail.

## Product description of high-precision version

### The measured deviations have the following cause

A roller circulation contains a number  $n$  of supporting rollers which are under load. If the roller runner block is moved into the direction of travel, via the entry zone, a new roller enters the load-bearing zone and  $n + 1$  roller are supporting. Thus, the internal balance of the four supporting rollers is disturbed. The roller runner block enters a rotational movement since the rollers can arbitrarily enter the supporting roller lines. In order to restore the balance, the roller runner block is moving into a new balance position. If the roller runner block is moved further, a supporting roller exits the load-bearing zone at the roller exit. Thus, the internal balance of the four supporting roller lines is disturbed again and the roller runner block enters a rotational movement. The effect can be clearly seen in the right-hand diagram.

As it has been verified in practical applications, the period of short-wave inaccuracies roughly corresponds to twice the roller diameter.

The remaining long-wave deviation is caused by the described causes 1, 2 and 3 (inaccurate mounting base, parallelism error and elastic deformation of the roller guide rail due to the fixing screws).

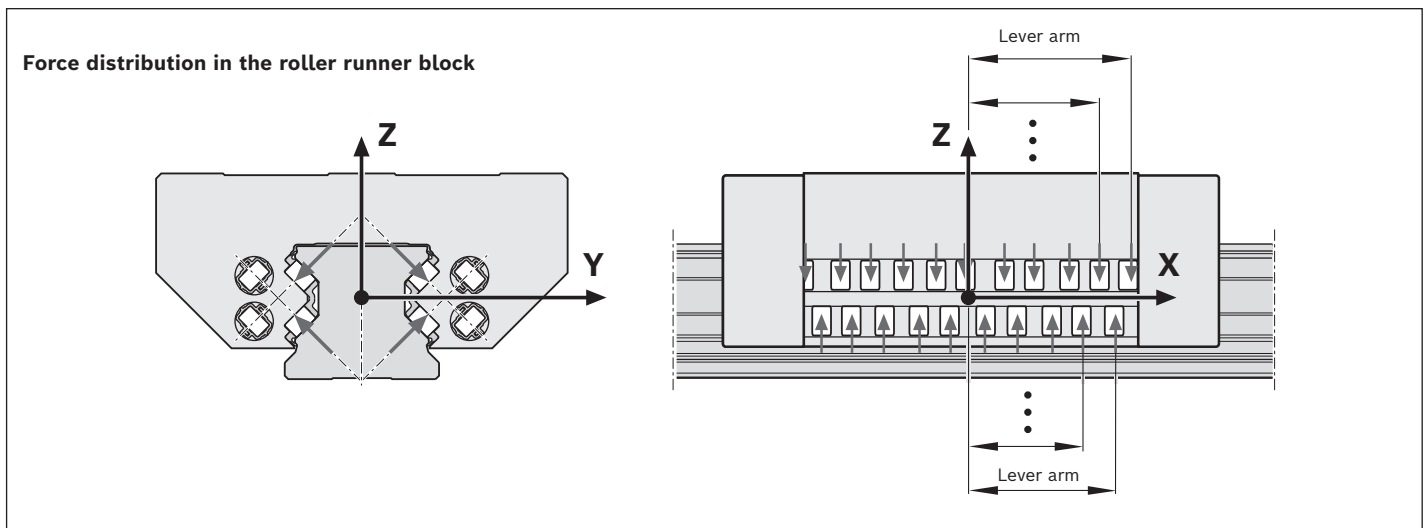





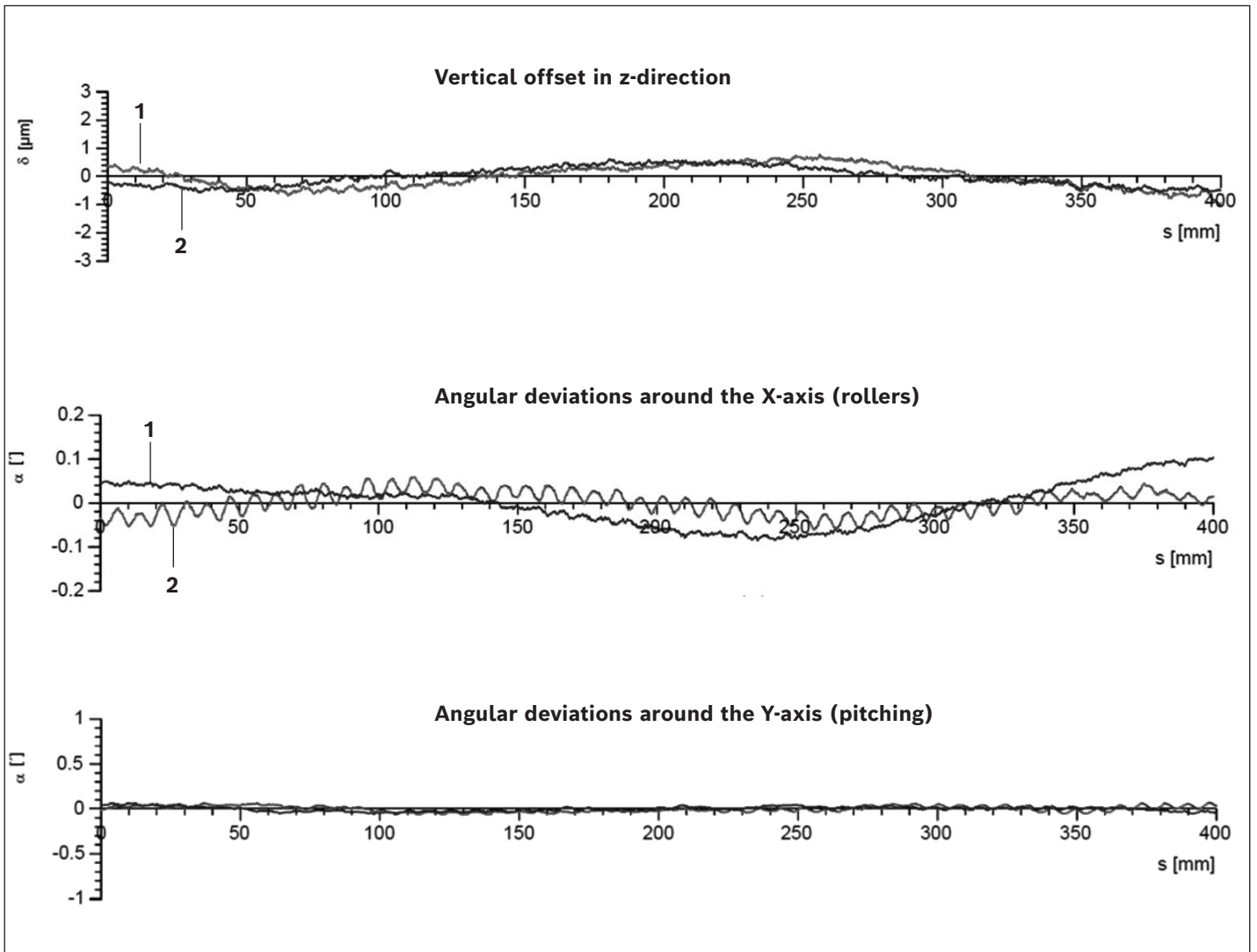





**Direct comparison of the travel accuracy of two roller runner blocks**

It can be clearly seen that the short-wave inaccuracy can be significantly reduced by the new optimized design of the entry zone.









- 1) High-precision version
- 2) Conventional version

# Product overview, roller runner blocks with load capacities

Roller runner block			Page	Size							
				25	35	45	55	65	100	125	
			Load capacities <sup>1)</sup> (N)								
											
<b>Standard roller runner block made of steel</b>		FNS R1851 ... 2.	50	<b>C</b>	26900	61000	106600	140400	237200		
		R1851 ... 7. Resist CR	62	<b>C<sub>0</sub></b>	59500	119400	209400	284700	456300		
		FLS R1853 ... 2.	52	<b>C</b>	33300	74900	132300	174000	295900		
		R1853 ... 7. Resist CR	62	<b>C<sub>0</sub></b>	76400	155400	276400	374900	606300		
		SNS R1822 ... 2.	54	<b>C</b>	26900	61000	106600	140400	237200		
		R1822 ... 7. Resist CR	62	<b>C<sub>0</sub></b>	59500	119400	209400	284700	456300		
		SLS R1823 ... 2.	56	<b>C</b>	33300	74900	132300	174000	295900		
		R1823 ... 7. Resist CR	62	<b>C<sub>0</sub></b>	76400	155400	276400	374900	606300		
		SNH R1821 ... 2.	58	<b>C</b>	26900	61000	106600	140400	-		
		R1821 ... 7. Resist CR	62	<b>C<sub>0</sub></b>	59500	119400	209400	284700	-		
		SLH R1824 ... 2.	60	<b>C</b>	33300	74900	132300	174000	-		
		R1824 ... 7. Resist CR	62	<b>C<sub>0</sub></b>	76400	155400	276400	374900	-		
<b>Heavy-duty roller runner blocks made of steel</b>		FXS R1854 ... 10	86	<b>C</b>		-		366800	-	-	
				<b>C<sub>0</sub></b>		-		792800	-	-	
		FNS R1861 ... 10	88	<b>C</b>			-		461000	757200	
		R1861 ... 60 Resist CR	88	<b>C<sub>0</sub></b>			-		811700	1324000	
		FLS R1863 ... 10	90	<b>C</b>			-		632000	1020000	
		R1863 ... 60 Resist CR	90	<b>C<sub>0</sub></b>			-		1218000	1941900	

1) Determination of the dynamic load capacities and load moments is based on a travel of 100,000 m according to DIN ISO 14728-1. Often only 50,000 m are actually stipulated. For comparison: Multiply values C, M<sub>t</sub> and M<sub>l</sub> from the table by 1.23.

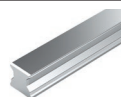
# Product overview of roller guide rails with lengths

Roller guide rails				Page	Size					
					25	35	45	55	65	
				Rail length (mm)						
<b>Standard roller guide rails made of steel<sup>1)</sup> and Resist CR/CRII<sup>3)</sup> for bolting from above</b>	 with cover strip and strip clamp	SNS	R1805 .3. ..	66	3986	3996	3986	3956	3971	
		SNO	R1845 ... .. Resist CR	78/80						
	 with cover strip and protective caps	SNS	R1805 .6. ..	68						
		SNO	R1845 ... .. Resist CR/CRII	78/80						
	 for cover strip	SNS	R1805 .2. ..	70						
		SNO	R1845 ... .. Resist CR/CRII	78/80						
	 with plastic caps	SNS	R1805 .5. ..	72						
		SNO	R1845 ... .. Resist CR/CRII	78/80						
	 with steel caps	SNS	R1806 .5. ..	74						
		SNO	R1846 ... .. Resist CR	78/80						
	<b>Standard roller guide rails made of steel<sup>2)</sup> and Resist CR/CRII<sup>3)</sup> for bolting from below</b>		SNS	R1807 .0. ..						76
			SNO	R1847 ... .. Resist CR/CRII						78/80
					<b>100</b>					
					<b>125</b>					
<b>Heavy-duty roller guide rail made of steel</b>	 with cover strip / with steel caps	SNS	R1835 .6. ..	92	3986			2760		
			R1836 .5. ..	94						
			R1865 .6. .. Resist CR	92	2500	2000				

1) Size 35: also available in one piece up to length 5996 mm, size 45: also available in one piece up to length 5981 mm, size 55: also available in one piece up to length 5936 mm, size 65: also available in one piece up to length 5921 mm

2) Size 35: also deliverable as one piece up to a length of 5996 mm

3) Resist CR: Roller guide rails made of steel with low-corrosion coating in matte-silver or black, hard chrome plated

## General technical data and calculations

### General notes

General technical data and calculations apply to all roller rail systems, i.e. all roller runner blocks and roller guide rails. Specific technical data are listed separately for the individual roller runner blocks and roller guide rails.

### Preload classes

To cover the widest possible range of applications, the Rexroth roller runner blocks (FW) are available in different preload classes.

The following preload classes are available:

- ▶ FW with preload class C2
- ▶ FW with preload class C3

Risk analysis on request:

- ▶ FW with preload class C1, C4, C5

To prevent reductions to the service life, the preload should not exceed 1/3 of the load on bearing F.

In general, the rigidity of the roller runner block rises with increasing preload.

### Guide systems with parallel rails

When choosing the preload class, also pay attention to the permissible parallelism offset of the rails (see "Accuracy class selection criterion").

### Speed

$$v_{\max} = 4^{1)} \text{ m/s}$$

- 1) Sizes:  
65 FXS: 3 m/s  
100 and 125: 2 m/s

### Acceleration

$$a_{\max} = 150 \text{ m/s}^2$$

Requirement:  
There must be preload, even during operation under load.

### Operating temperature range

$$-10 \text{ °C} \dots +80 \text{ °C}$$

Up to 100°C is permissible for a short time.  
For operation at lower minus temperatures, please consult us.

## Friction

The table contains guideline values for the friction forces of the complete, sealed and lubricated roller runner block without connection elements. When starting up the roller runner block, the friction force may have a value of 1.5- to 2-fold normal, depending on downtime, selection, quantity and state of the lubricant as well as contamination of the roller guide rail. This applies for all roller runner blocks in all preload classes. The friction coefficient  $\mu$  amounts to 0.0004 to 0.001 (without the friction of the sealings).

Size	Friction force $F_R$ (N)			
	double lipped seal	single lipped seal, stripping	single lipped, gap	with longitudinal seal
	DS	SS	LS	AS
25	30	–	–	–
35	35	30	25	80
45	40	35	30	120
55	45	–	–	140
65	60	–	–	–
100	400 <sup>1)</sup>	–	–	–
125	600 <sup>1)</sup>	–	–	–

1) The friction is approx. 50 % higher immediately after lubrication.

## Seals

Seals are used to prevent dirt, chips etc. from working their way into the inside of the roller runner block, thereby preventing reductions to its service life. This also prevents the discharge of lubricant.

## Standard

Seals are fitted at the Rexroth roller runner block by default. They have a uniform sealing effect for roller guide rails with and without cover strips.

## FKM seals

FKM seal are available as additional elements and are mounted by the customer. They are intended for the use in environments with many fine dirt or metal particles.

- ▶ Use in environments with dirt or metal particles and, additionally, cooling and cutting liquids.
- ▶ Interchangeable during servicing.

## Cover plate wiper

Cover plate wipers are available as additional elements and are mounted by the customer.

- ▶ For the use in environments with hot coarse chips or beads of sweat.

## Seals

The sealing plate on the end face (1) protects the interior of the roller runner block against dirt, chips and fluids. Additionally, it prevents the discharge of lubricant. Due to the optimized form of the sealing lips, the occurring friction is reduced to a minimum. Sealing plates are optionally available with green double-lip seals (DS), black standard seals (SS) or brown low-friction seals (LS).

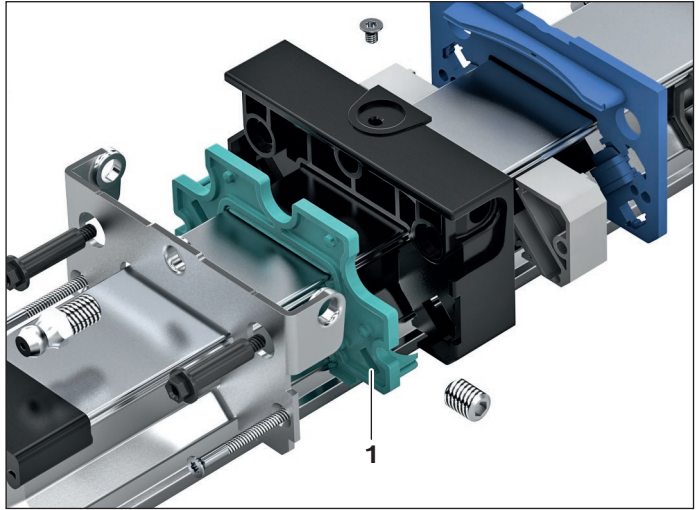

### **Double-lip seal DS** (sealing with very good sealing effect)

For applications in which the rail guide is heavily charged with chips, wood dust, cooling lubricants etc., Rexroth recommends the double-lip seal. It comprises an excellent wiping action but a greater friction force and lower relubrication interval.

### **Standard seal SS** (universal sealing with good sealing effect)

For most application cases, the standard seal is suitable. It comprises of a good wiping action but also enables long relubrication intervals.

### **Low-friction seal LS** (seal with very low friction)

For special requirements with regard to ease of movement and reduced lubricant application, the low-friction seal has been developed. It only has a limited wiping action.

### **Sealing effect and displacement resistance**

The displacement resistance can be impacted by the geometry and the material. The diagram shows the effects of different sealing versions on the sealing effect and the displacement resistance.

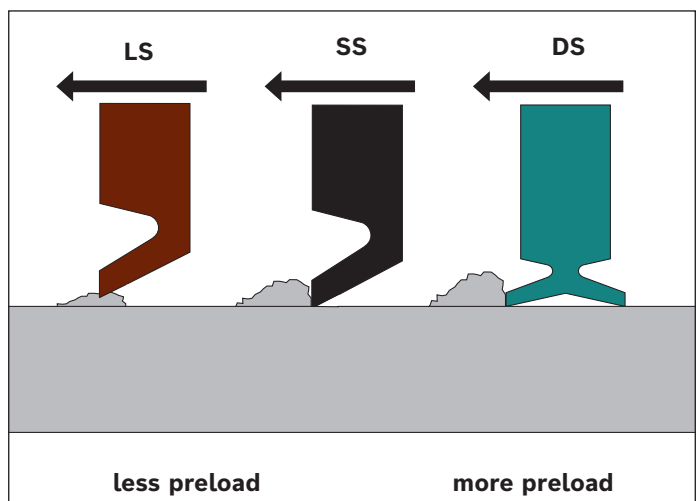
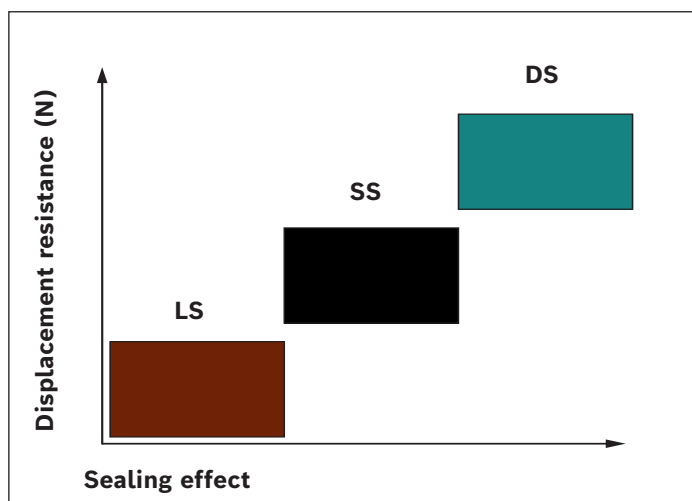

**Longitudinal seal**

- ▶ Area of use:  
Installation positions, horizontal over-head and wall installation
- ▶ Advantage:  
Early failure of the Runner Block is avoided.
- ▶ Sealing lip over the complete runner block length (including fins for the end-face sealing)

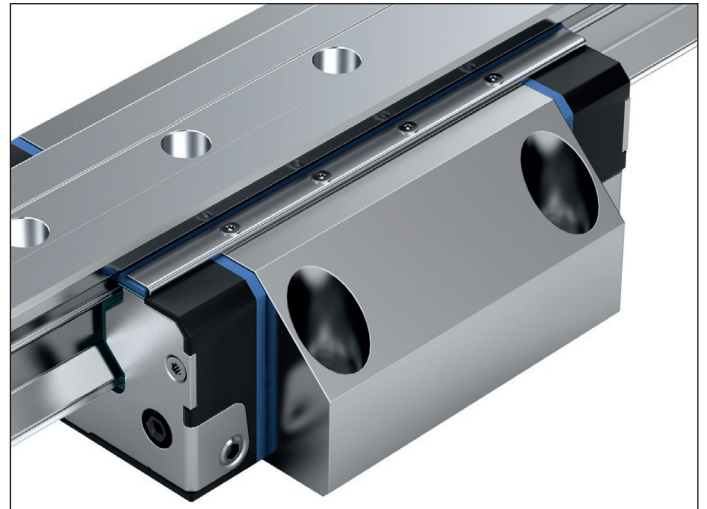

- ▶ Sealing lip with sharp edges for optimizing the friction
- ▶ Upright, preloaded sealing lip for a targeted deflection of dirt away from the sealing edge.
- ▶ Fixation via retaining plate (screwed)
- ▶ Optimum fastener at the Runner Block with 4 screws each
- ▶ High level of rigidity and clamping with edged retaining plate

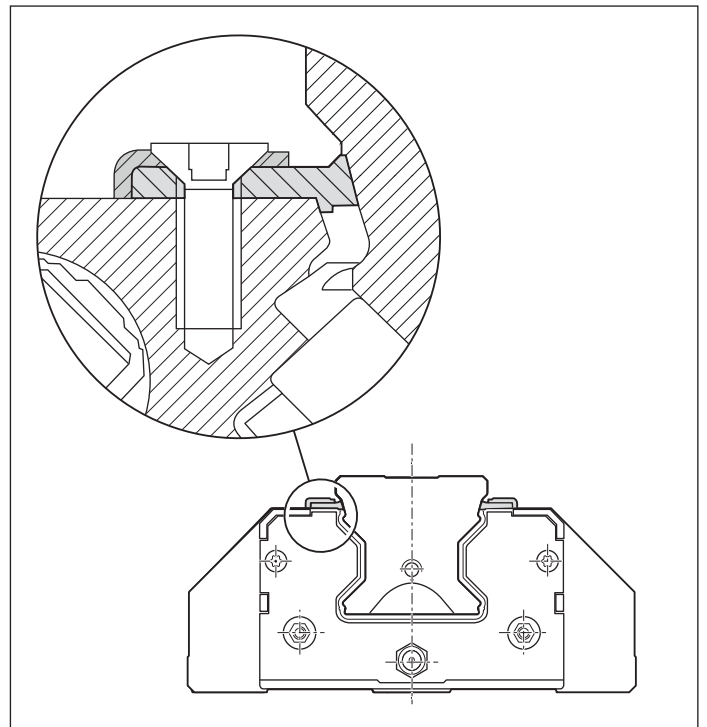

# General technical data and calculations

## Forces and moments

In Rexroth Roller rail systems the tracks are arranged at a pressure angle of 45°. This results in the same high load capacity of the entire system in all four main directions of loading. The roller runner blocks may be subjected to both forces and load moments.

### Forces in the four main directions of loading

- ▶ Tension  $F_z$  (positive z-direction)
- ▶ Pressure  $-F_z$  (negative z-direction)
- ▶ Side load  $F_y$  (positive y-direction)
- ▶ Side load  $-F_y$  (negative y-direction)

### Moments

- ▶ Moment  $M_x$  (around the x-axis)
- ▶ Moment  $M_y$  (around the y-axis)
- ▶ Moment  $M_z$  (around the z-axis)

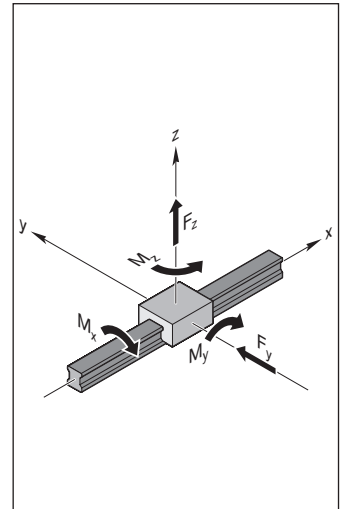

## Definition of load capacities

### Dynamic load capacity C

The radial load the size and direction of which does not change and which a linear anti-friction bearing can theoretically absorb for a nominal service life covering  $10^5$  m (according to ISO 14728-1).

Note: The dynamic load capacities in the tables are above the ISO values. These values have been confirmed in tests.

### Static load capacity $C_0$

Static load in the direction of loading that corresponds to a calculated load in the center of the contact point with the greatest load between the rolling element and the track zone (rail) of 4000 MPa.

Note: With this stress at the contact point, permanent overall deformation of the rolling element and the track zone occurs that corresponds to about 0.0001 times the rolling element diameter (according to DIN ISO 14 728-1).

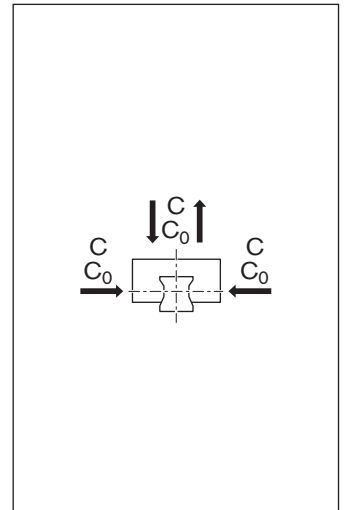

## Definition of load moment capacities

### Dynamic torsional moment load capacity $M_t$

Comparative dynamic moment around the longitudinal axis x, which causes a load equivalent to the dynamic load capacity C.

### Static torsional moment load capacity $M_{t0}$

The comparable static moment around the longitudinal axis x, which causes a load corresponding to the static load capacity  $C_0$ .

### Dynamic longitudinal moment load capacity $M_L$

The dynamic comparable dynamic moment around the transverse axis y or the vertical axis z that induces a load corresponding to the dynamic load capacity C.

### Static longitudinal moment load capacity $M_{L0}$

The static comparable moment around the transverse axis y or the vertical axis z that induces a load corresponding to the static load capacity  $C_0$ .

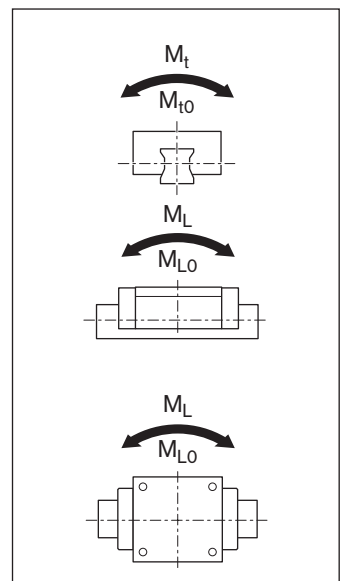

**Definition and calculation of the nominal service life**

The calculated service life which an individual linear rolling bearing or a group of apparently identical rolling element bearings operating under the same conditions can attain with a 90% probability using contemporary, commonly used materials and manufacturer quality under conventional operating conditions (according to DIN ISO 14 728-1).

**Nominal service life in meters**

$$(1) L_{10} = \left( \frac{C}{F_m} \right)^{10/3} \cdot 10^5 \text{ m}$$

**Service life in operating hours with constant stroke and constant stroke repetition rate**

$$(2) L_{h10} = \frac{L_{10}}{2 \cdot s \cdot n \cdot 60} \text{ h}$$

If the stroke length  $s$  and the stroke repetition rate  $n$  are constant over the total service life, you can use formula (2) to determine the service life in operating hours.

**Nominal service life at variable travel speed**

$$(3) L_{h10} = \frac{L_{10}}{60 \cdot v_m}$$

As an alternative, it is possible to use formula (3) to calculate the service life in operating hours using the average speed  $v_m$ . This average speed  $v_m$  is calculated with speeds that can be changed on a stepwise basis using the time steps  $q_{tn}$  of the individual load stages (4).

$$(4) v_m = \frac{|v_1| \cdot q_{t1} + |v_2| \cdot q_{t2} + \dots + |v_n| \cdot q_{tn}}{100\%}$$

**Modified life expectancy**

$$L_{na} = a_1 \cdot \left( \frac{C}{F_m} \right)^{10/3} \cdot 10^5 \text{ m}$$

$$L_{ha} = \frac{L_{na}}{2 \cdot s \cdot n \cdot 60} \text{ h}$$

If a 90 percent requisite reliability is not enough, you must reduce the service life values by a factor of  $a_1$  in accordance with the table below.

Requisite reliability (%)	$L_{na}$	Factor $a_1$
90	$L_{10a}$	1.00
95	$L_{5a}$	0.64
96	$L_{4a}$	0.55
97	$L_{3a}$	0.47
98	$L_{2a}$	0.37
99	$L_{1a}$	0.25

**Notes**

DIN ISO 14 728-1 limits the validity of the formula (1) to dynamically equivalent loads  $F_m < 0.5 C$ . However, in our tests we verified that under ideal operating conditions this service life formula can be applied up to loads of  $F_m = C$ . Under some circumstances, with stroke lengths below  $2 \cdot$  roller runner block length  $B_1$  (see the dimension tables) a load capacity reduction may be required. Please consult us.

## General technical data and calculations

### Load on bearing for calculating the service life

#### Combined equivalent bearing load

Using formula (5), you can combine all the partial loads that occur in a load case into one single comparison load, i.e. the combined equivalent load on bearing.

#### Notes

Including moments as stated in formula (5) only applies to an individual roller guide rails with just one roller runner block. The formula is simpler for other combinations.

The forces and moments plotted in the coordinate system can also have an effect in the opposite direction. Reduce an external load that affects the roller runner block at any angle to  $F_y$  and  $F_z$  and insert the amounts into formula (5). The structure of the roller runner block permits this simplified calculation.

$$(5) \quad F_{\text{comb}} = |F_y| + |F_z| + C \cdot \frac{|M_x|}{M_t} + C \cdot \frac{|M_y|}{M_L} + C \cdot \frac{|M_z|}{M_L}$$

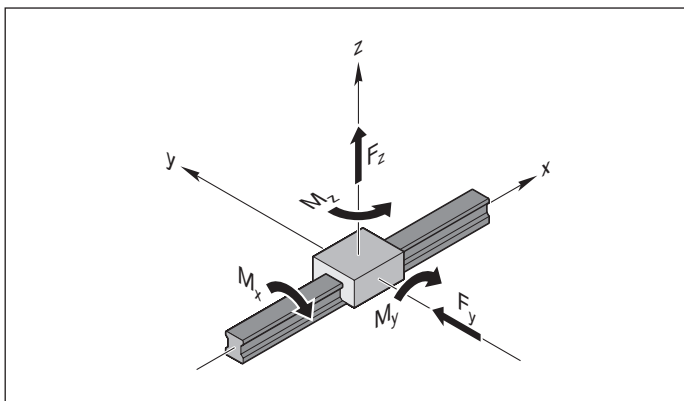

**Considering the internal preload force  $F_{pr}$**

To increase the rigidity and precision of the guide system, it is advisable to use preloaded roller runner blocks (cf. "System preload selection criterion").

When using roller runner blocks of preload classes C2 and C3, it may be necessary to consider the internal preload force; this is because both rows of rollers a and b are preloaded against one another by a specific oversize at an internal preload force  $F_{pr}$  and deform by the amount  $\delta_{pr}$  (see the diagram).

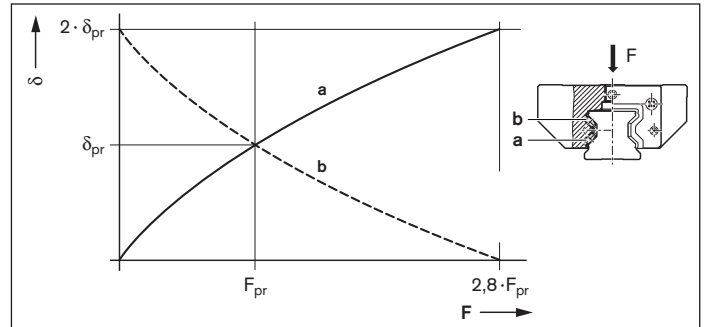

- a = Loaded (lower) row of rollers
- b = Non-loaded (upper) row of rollers
- $\delta$  = Deformation of the rollers at F
- $\delta_{pr}$  = Deformation of the rollers at  $F_{pr}$
- F = Load on the roller runner block
- $F_{pr}$  = Internal preload force

**Effective equivalent load on bearing**

From an external load amounting to 2.8 times the internal preload force  $F_{pr}$  onward, a row of rollers becomes preload-free.

**Note**

Under highly dynamic load conditions, the combined equivalent bearing load should be  $F_{comb} < 2.8 \cdot F_{pr}$  to prevent damage to anti-friction bearings due to slippage.

$$(6) \quad F_{eff} = F_{comb}$$

**Case 1**

$F_{comb} > 2.8 \cdot F_{pr}$   
In this case, the internal preload force  $F_{pr}$  does not affect the service life.

$$(7) \quad F_{eff} = \left( \frac{F_{comb}}{2.8 \cdot F_{pr}} + 1 \right)^{3/2} \cdot F_{pr}$$

**Case 2**

$F_{comb} \leq 2.8 \cdot F_{pr}$   
The preload force  $F_{pr}$  is included in the calculation of the effective equivalent load on bearing.

## General technical data and calculations

### Dynamically equivalent load on bearing

The determination of the dynamically equivalent load on bearing  $F_m$  for the calculation of the service life is implemented according to portions of distance  $q_{sn}$  according to the formula (8).

$$(8) \quad F_m = \sqrt[10]{(F_{\text{eff } 1})^{\frac{10}{3}} \cdot \frac{q_{s1}}{100\%} + (F_{\text{eff } 2})^{\frac{10}{3}} \cdot \frac{q_{s2}}{100\%} + \dots + (F_{\text{eff } n})^{\frac{10}{3}} \cdot \frac{q_{sn}}{100\%}}$$

### Equivalent static load on bearing

With a combined vertical and horizontal external static load in conjunction with a static torsional or longitudinal moment, calculate the static equivalent load on bearing  $F_{0 \text{ comb}}$  according to formula (9).

$$(9) \quad F_{0 \text{ comb}} = |F_{0y}| + |F_{0z}| + C_0 \cdot \frac{|M_{0x}|}{M_{t0}} + C_0 \cdot \frac{|M_{0y}|}{M_{L0}} + C_0 \cdot \frac{|M_{0z}|}{M_{L0}}$$

### Notes

The static equivalent load on bearing  $F_{0 \text{ comb}}$  must not exceed the static load capacity  $C_0$ . Formula (9) only applies when using a single roller guide rail.

Reduce an external load that affects the roller runner block at any angle to  $F_{0y}$  and  $F_{0z}$  and insert the amounts into formula (9).

### Definitions and calculation for dynamic and static load ratios

Using the ratio of load capacity to load of the roller runner block, you can make a preselection of the guideway.

The dynamic loading ratio  $C/F_{\text{max}}$  and the static loading ratio  $C_0/F_{0 \text{ max}}$  should be selected according to the application.

The necessary load capacities are calculated from this. The load capacity overview yields the corresponding size and format.

### Guideline values for load ratios

The table below contains guideline values for the load ratios.

The table values are offered merely as a rough guide reflecting typical customer requirements (e.g. service life, accuracy, rigidity) by sector and application.

**Case 1:** Static load  $F_{0 \text{ max}} > F_{\text{max}}$ :

**Case 2:** Static load  $F_{0 \text{ max}} < F_{\text{max}}$ :

$$\text{Dynamic ratio} = \frac{C}{F_{\text{max}}}$$

$$\text{Static ratio} = \frac{C_0}{F_{0 \text{ max}}}$$

$$\text{Static ratio} = \frac{C_0}{F_{\text{max}}}$$

Machine type/sector	Application example	C/F <sub>max</sub>
Machine tools	General	6 ... 9
	Turning	6 ... 7
	Milling	6 ... 7
	Grinding	9 ... 10
	Engraving	5
Rubber and plastics processing machinery	Injection molding	8
Woodworking and wood processing machines	Sawing, milling	5
Area of mounting/handling technology and industrial robots	Handling	5
Oil hydraulics and pneumatics	Raising/lowering	6

### Static load safety factor $S_0$

You must verify mathematically any structural design involving rolling contact with regard to the static load safety factor. The static load safety factor for a linear guide results from the following equation:

$$(10) \quad S_0 = \frac{C_0}{F_{0 \max}}$$

In this connection,  $F_{0 \max}$  represents the maximum load amplitude that can occur, which can affect the linear guide. It does not matter whether this load is exerted only for a short period. It may represent the peak amplitude of an overall dynamic loading. For sizing, the data shown in the table applies.

Conditions of use	Static load safety factor $S_0$
Overhead arrangements and applications representing a high hazard potential	$\geq 12$
High dynamic load when at standstill, contamination.	8 - 12
Normal sizing of machinery and plants without full knowledge of the load parameters or connection details.	5 - 8
Full knowledge of all the load data. Vibration-free operation is ensured.	3 - 5
If there are health and safety hazards, paragraph 5.1.3 of DIN 637 is to be observed.	

### Key to formulas

Formula	Unit	Designation
$a_1$	–	Likelihood of experience factor
$C$	N	Dynamic load capacity
$C_0$	N	Static load capacity
$F_{\max}$	<b>N</b>	Maximum dynamic load
$F_{0 \max}$	<b>N</b>	Maximum static load
$F_{\text{comb}}$	N	Combined equivalent bearing load
$F_{0 \text{comb}}$	N	Equivalent static load on bearing
$F_{\text{eff}}$	N	Effective equivalent load on bearing
$F_{\text{eff } 1-n}$	N	Uniform effective individual loads
$F_m$	N	Dynamically equivalent load on bearing
$F_{\text{pr}}$	N	Preload force
$F_y$	N	External load due to a resulting force in y-direction
$F_{0y}$	N	External load due to a static force in y-direction
$F_z$	N	External load due to a resulting force in z-direction
$F_{0z}$	N	External load due to a static force in z-direction
$M_t$	Nm	Dynamic torsional moment load capacity <sup>1)</sup>
$M_{t0}$	Nm	Static torsional moment load capacity <sup>1)</sup>
$M_L$	Nm	Dynamic longitudinal moment load capacity <sup>1)</sup>
$M_{L0}$	Nm	Static longitudinal moment load capacity <sup>1)</sup>

Formula	Unit	Designation
$M_x$	Nm	Load due to the resultant moment around the x-axis
$M_{0x}$	Nm	Load due to the static moment around the x-axis
$M_y$	Nm	Load due to the resultant moment around the y-axis
$M_{0y}$	Nm	Load due to the static moment around the y-axis
$M_z$	Nm	Load due to the resultant moment around the z-axis
$M_{0z}$	Nm	Load due to the static moment around the z-axis
$L_{10}$	m	Nominal life (travel range)
$L_{h 10}$	h	Nominal life expectancy (time)
$L_{na}$	m	Modified life expectancy (travel range)
$L_{ha}$	h	Modified life expectancy (time)
$n$	rpm	Stroke repetition rate (full cycles)
$s$	m	Stroke length
$S_0$	–	Static load safety factor
$v_m$	m/min	Average speed
$v_1 \dots v_n$	m/min	Travel speeds of phases 1 ... n
$q_{t1} \dots q_{tn}$	%	Discrete time steps for $v_1 \dots v_n$ of phases 1 ... n
$q_{s1} \dots q_{sn}$	%	Portions of distance for phases 1 ... n

1) Refer to the table for the values

# Rigidity of standard roller runner block FNS

## Rigidity of Roller Rail System for preload C2

### Standard roller runner block FNS R1851

Roller runner block mounted with 6 screws:

- ▶ Externally with 4 screws of strength class 12.9
- ▶ In the middle with 2 screws of strength class 8.8

### Down load

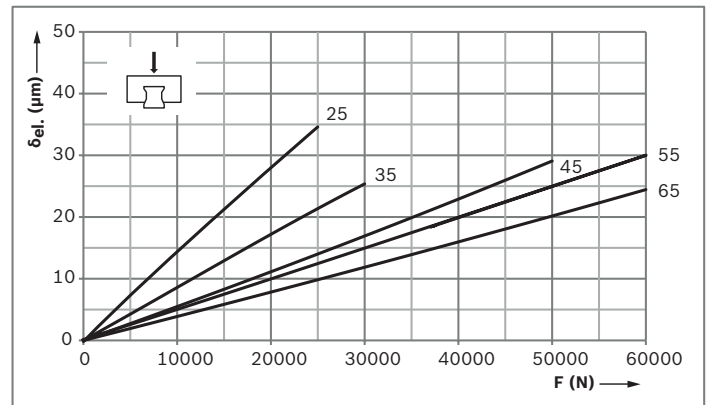

### Lift-off load

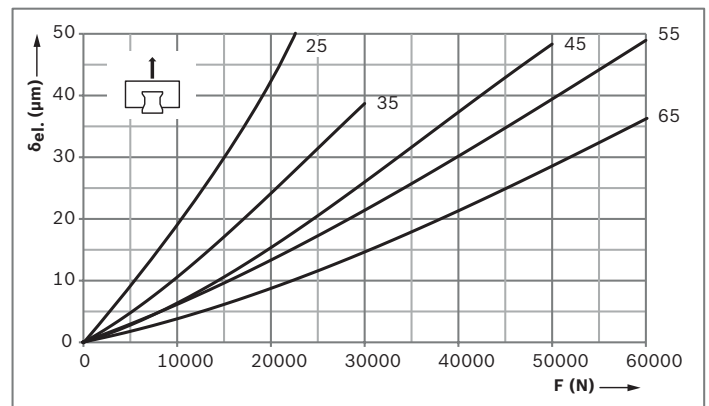

### Side load

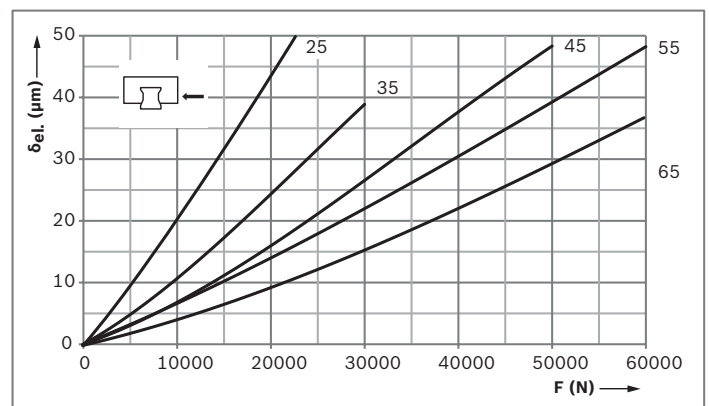

#### Preload class

C2 = Preload (acc. to Preload force  $F_{pr}$  table)

#### Key to illustration

$\delta_{el.}$  = Elastic deformation (μm)  
 $F$  = Load (N)

**Rigidity of Roller Rail System for preload C3**  
**Standard roller runner block FNS R1851**

- Roller runner block mounted with 6 screws:
- ▶ Externally with 4 screws of strength class 12.9
  - ▶ In the middle with 2 screws of strength class 8.8

**Down load**

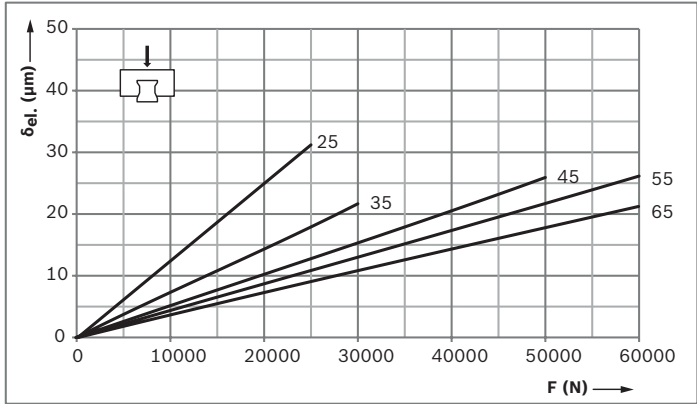

**Lift-off load**

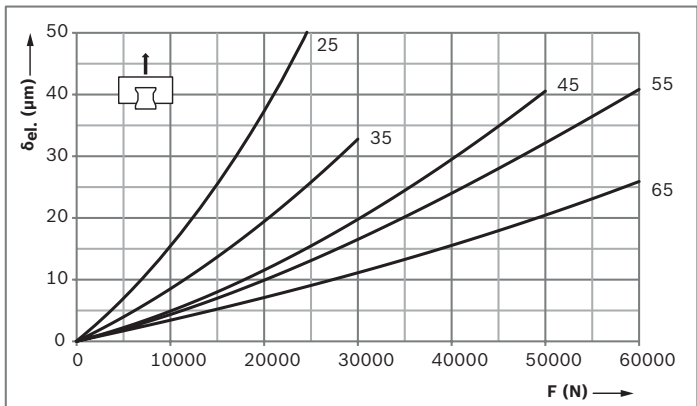

**Side load**

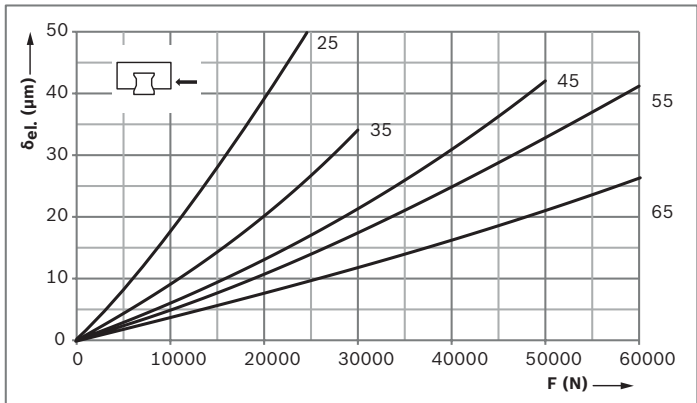

**Preload class**  
 C3 = Preload (acc. to Preload force  $F_{pr}$  table)

**Key to illustration**  
 $\delta_{el.}$  = Elastic deformation ( $\mu\text{m}$ )  
 $F$  = Load (N)

# Rigidity of standard roller runner block FLS

## Rigidity of Roller Rail System for preload C2

### Standard roller runner block FLS R1853

Roller runner block mounted with 6 screws:

- ▶ Externally with 4 screws of strength class 12.9
- ▶ In the middle with 2 screws of strength class 8.8

### Down load

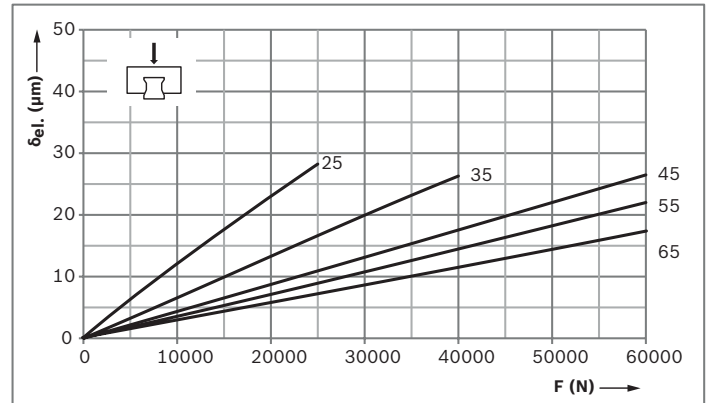

### Lift-off load

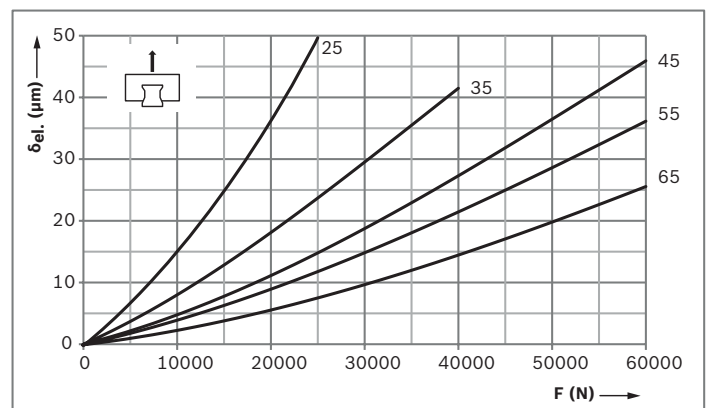

### Side load

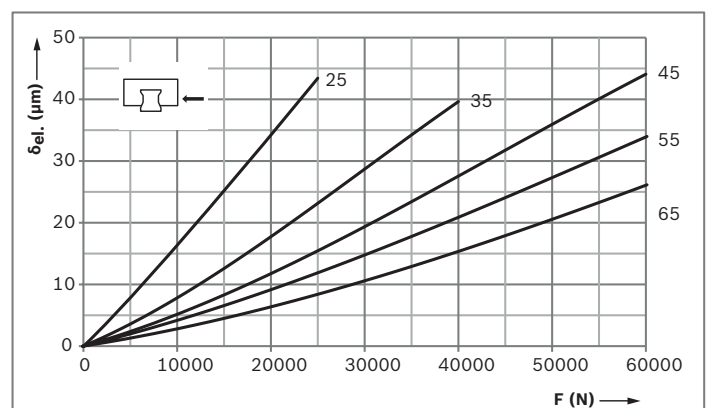

#### Preload class

C2 = Preload (acc. to Preload force  $F_{pr}$  table)

#### Key to illustration

$\delta_{el.}$  = Elastic deformation (μm)  
 $F$  = Load (N)

**Rigidity of Roller Rail System for preload C3**

**Standard roller runner block FLS R1853**

Roller runner block mounted with 6 screws:

- ▶ Externally with 4 screws of strength class 12.9
- ▶ In the middle with 2 screws of strength class 8.8

**Down load**

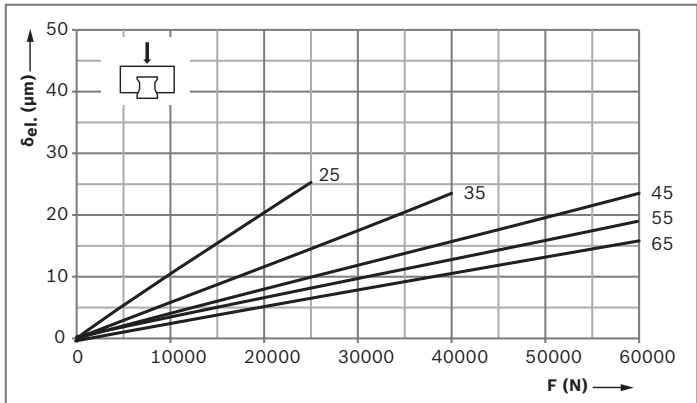

**Lift-off load**

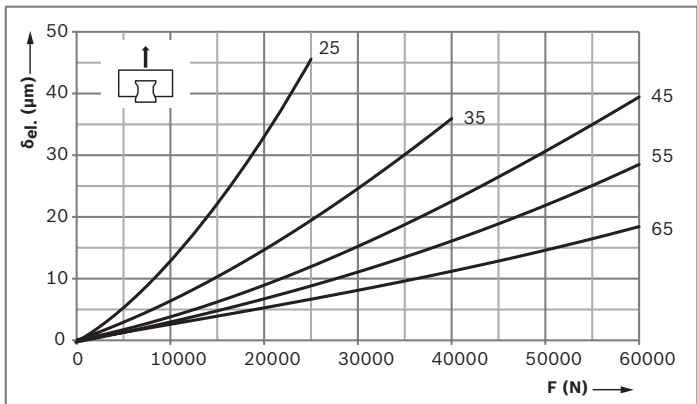

**Side load**

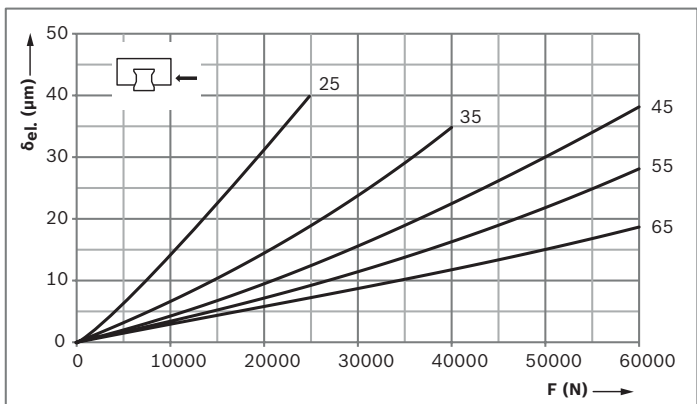

**Preload class**

C3 = Preload (acc. to Preload force  $F_{pr}$  table)

**Key to illustration**

$\delta_{el.}$  = Elastic deformation ( $\mu\text{m}$ )  
 F = Load (N)

# Rigidity of standard roller runner block SNS/SNH

## Rigidity of Roller Rail System for preload C2

### Standard roller runner blocks SNS R1822 / SNH R1821

Roller runner block mounted with 6 screws of strength class 12.9

#### Down load

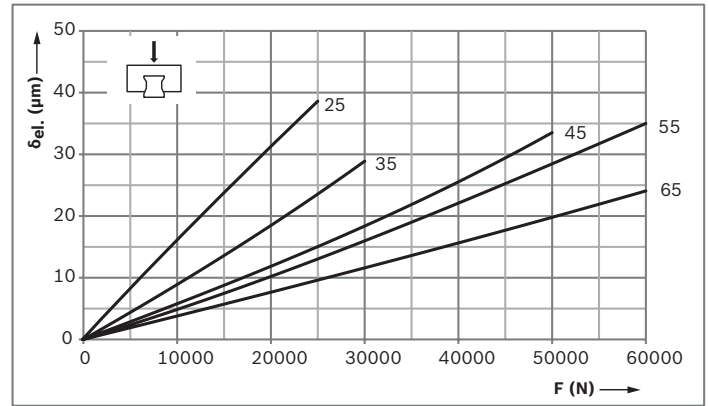

#### Lift-off load

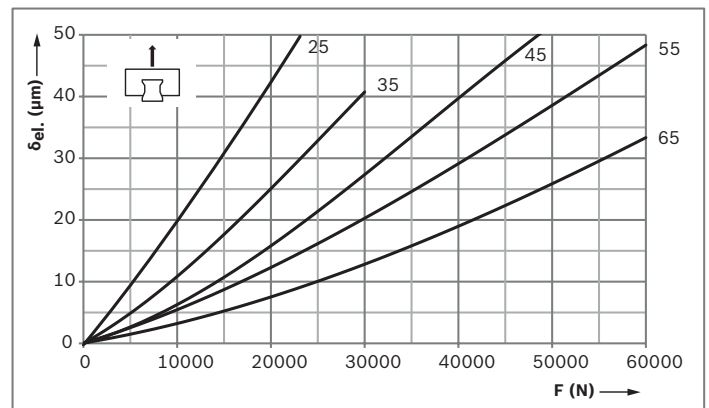

#### Side load

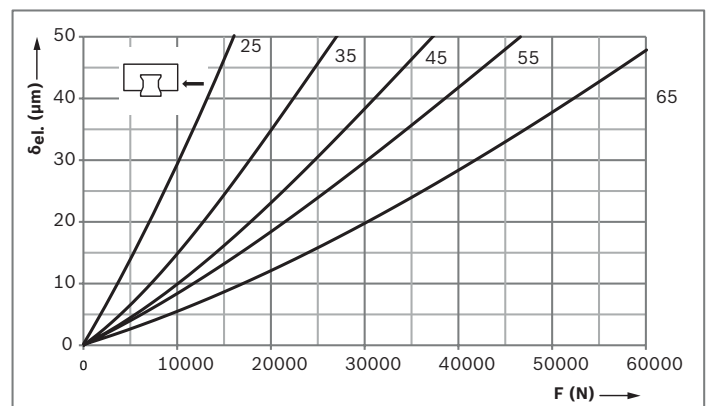

#### Preload class

C2 = Preload (acc. to Preload force  $F_{pr}$  table)

#### Key to illustration

$\delta_{el.}$  = Elastic deformation (μm)  
 $F$  = Load (N)

**Rigidity of Roller Rail System for preload C3**  
**Standard roller runner blocks SNS R1822 / SNH R1821**

Roller runner block mounted with 6 screws of strength class 12.9

**Down load**

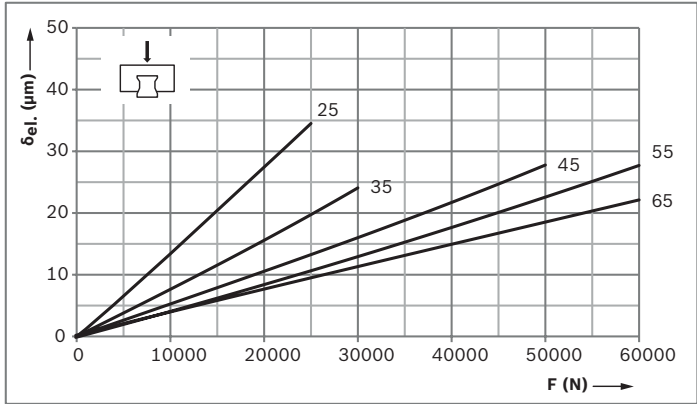

**Lift-off load**

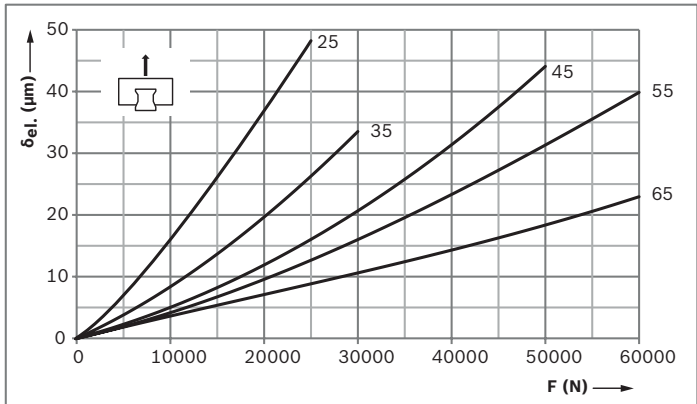

**Side load**

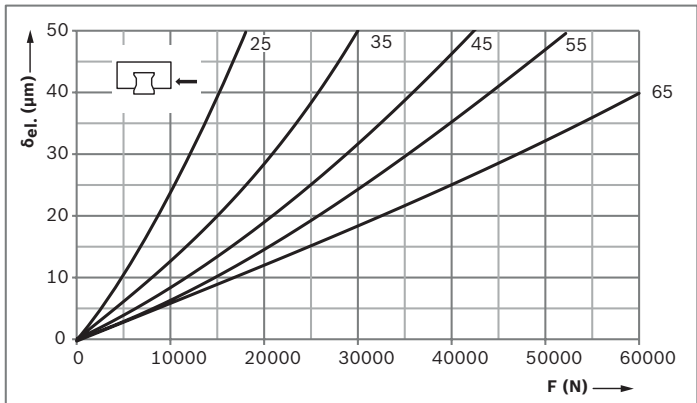

**Preload class**  
 C3 = Preload (acc. to Preload force F<sub>pr</sub> table)

**Key to illustration**  
 δ<sub>el.</sub> = Elastic deformation (μm)  
 F = Load (N)

# Rigidity of standard roller runner block SLS/SLH

## Rigidity of Roller Rail System for preload C2

### Standard roller runner blocks SLS R1823/SLH R1824

Roller runner block mounted with 6 screws of strength class 12.9

#### Down load

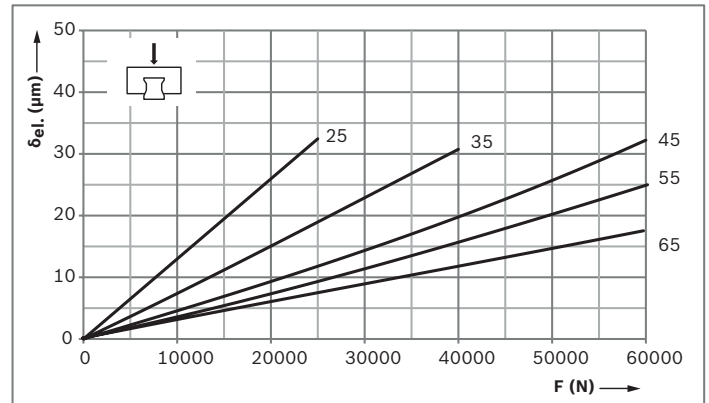

#### Lift-off load

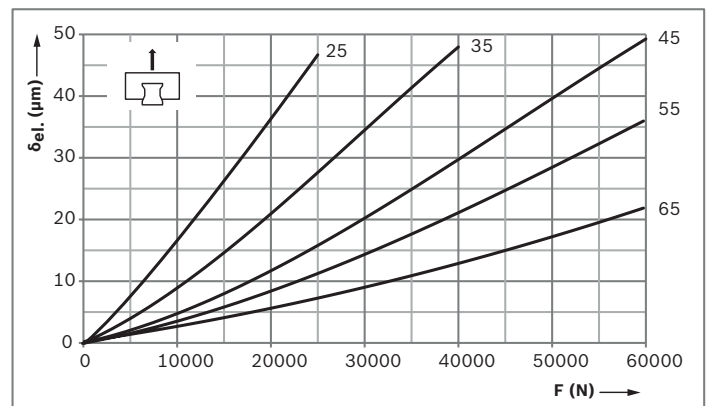

#### Side load

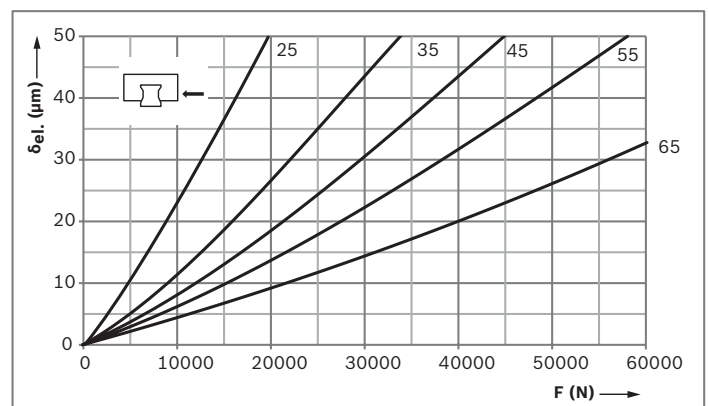

#### Preload class

C2 = Preload (acc. to Preload force  $F_{pr}$  table)

#### Key to illustration

$\delta_{el.}$  = Elastic deformation ( $\mu\text{m}$ )  
 $F$  = Load (N)

**Rigidity of Roller Rail System for preload C3**  
**Standard roller runner blocks SLS R1823/SLH R1824**  
 Roller runner block mounted with 6 screws of strength class 12.9

**Down load**

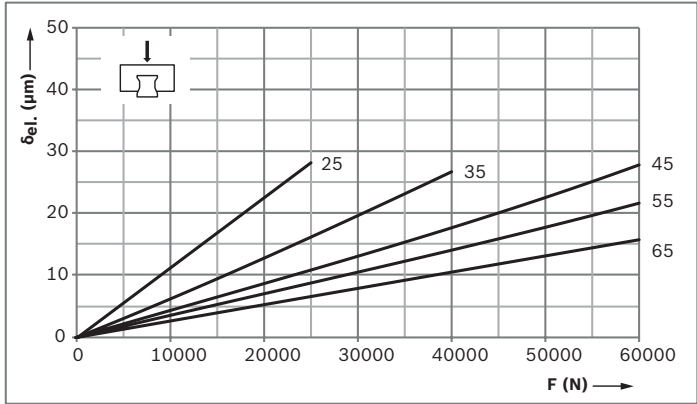

**Lift-off load**

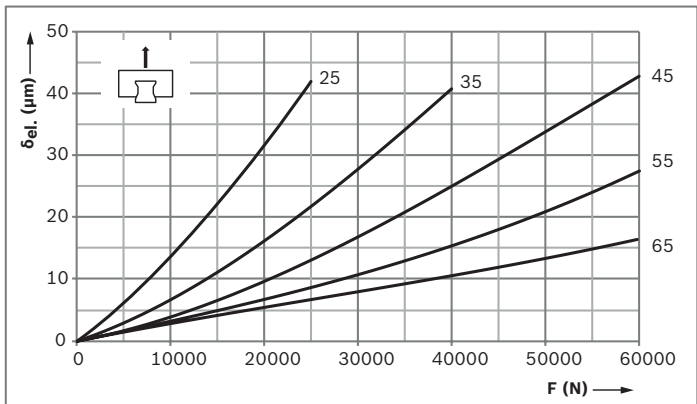

**Side load**

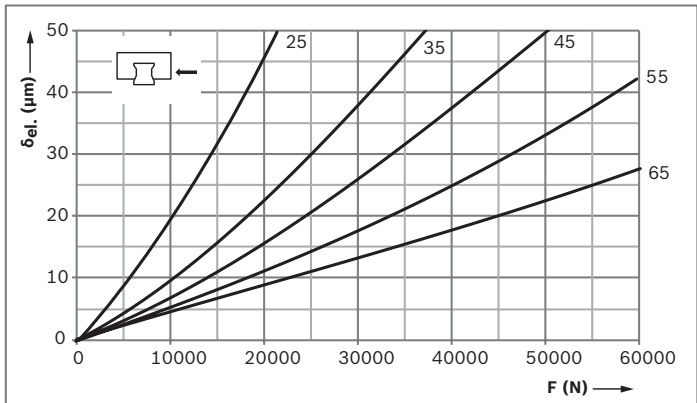

**Preload class**  
 C3 = Preload (acc. to Preload force F<sub>pr</sub> table)

**Key to illustration**  
 δ<sub>el.</sub> = Elastic deformation (μm)  
 F = Load (N)

# Rigidity of heavy-duty roller runner blocks FNS

## Rigidity of Roller Rail System for preload C3

### FNS heavy-duty roller runner blocks R1861

Roller runner block mounted with 9 screws:

- ▶ Externally with 6 screws of strength class 12.9
- ▶ Centrally with 3 screws of strength class 8.8

### Down load

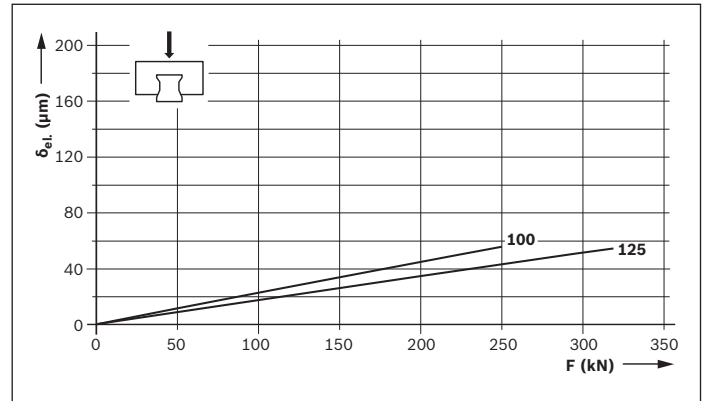

### Lift-off load

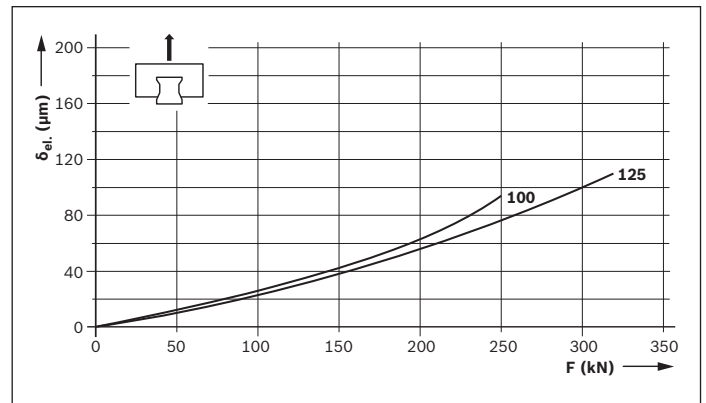

### Side load

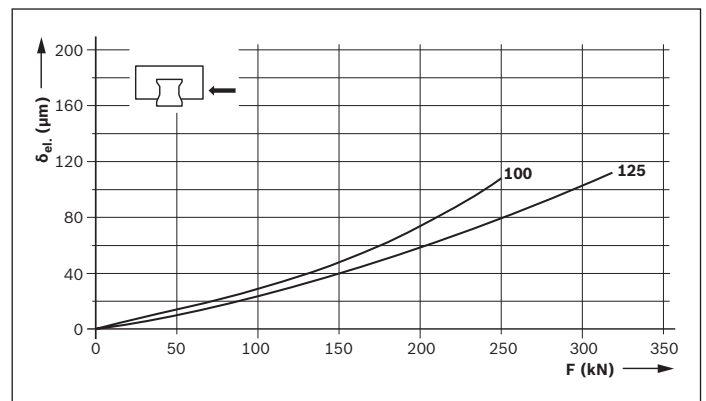

#### Preload class

C3= Preload (acc. to Preload force  $F_{pr}$  table)

#### Key to illustration

$\delta_{el.}$  = Elastic deformation (μm)  
 $F$  = Load (N)

# Rigidity of heavy-duty roller runner blocks FLS

## Rigidity of Roller Rail System for preload C3

### Heavy-duty roller runner blocks FLS R1863

Roller runner block mounted with 9 screws:

- ▶ Externally with 6 screws of strength class 12.9
- ▶ Centrally with 3 screws of strength class 8.8

### Down load

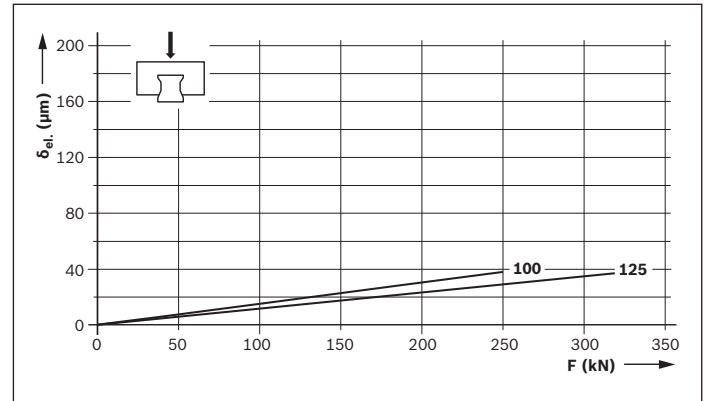

### Lift-off load

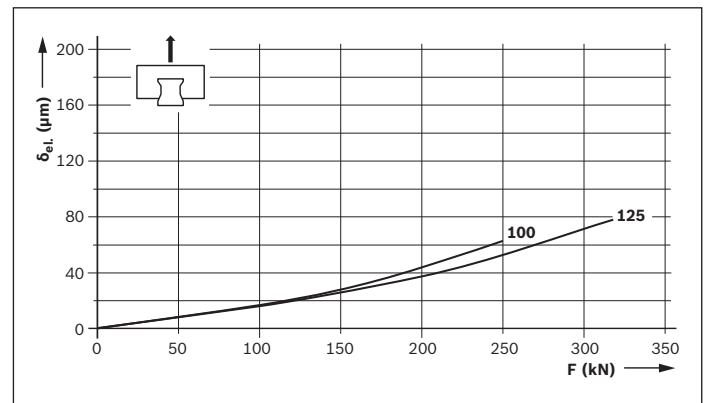

### Side load

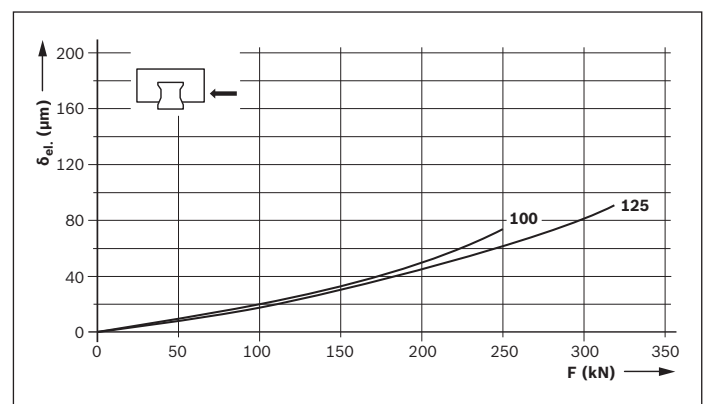

#### Preload class

C3 = Preload (acc. to Preload force  $F_{pr}$  table)

#### Key to illustration

$\delta_{el.}$  = Elastic deformation (μm)  
 F = Load (N)

# Rigidity of heavy-duty roller runner blocks FXS

## Rigidity of Roller Rail System for preload C2

### Heavy-duty roller runner blocks FXS R1854

Roller runner block mounted with

- ▶ 4 screws, strength class 12.9
- ▶ 2 screws, strength class 8.8

#### Down load

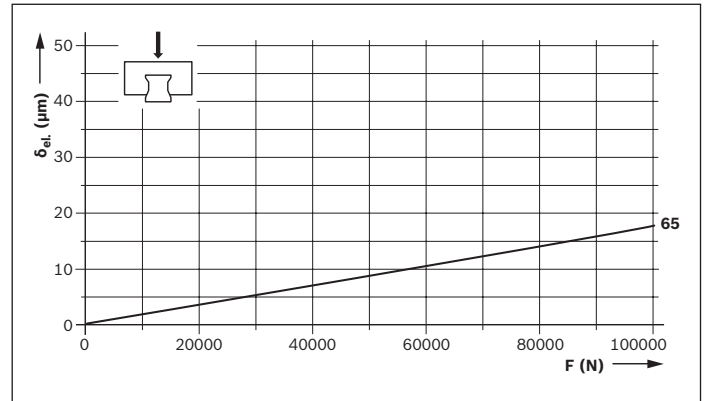

#### Lift-off load

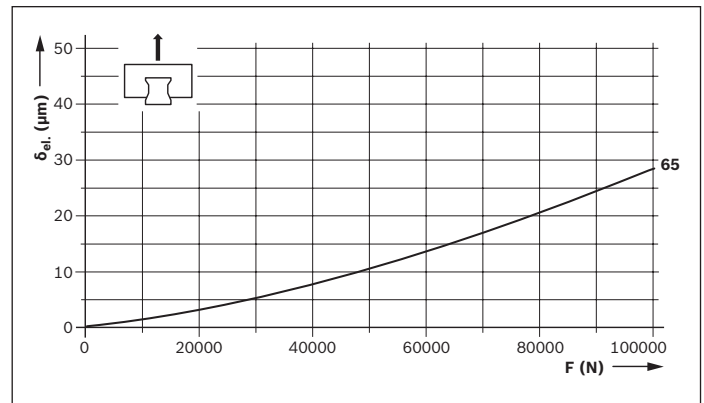

#### Side load

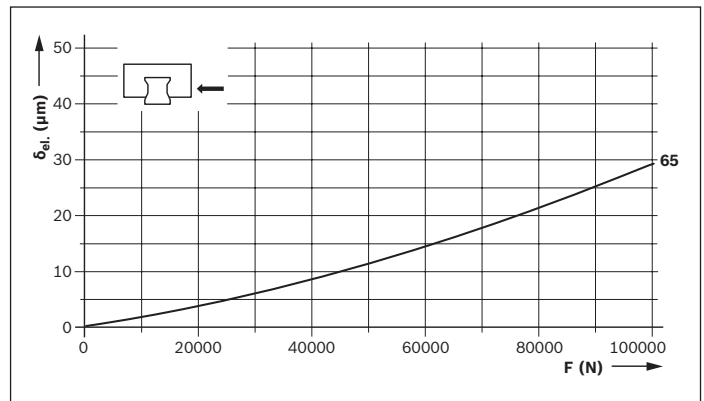

#### Preload class

C2 = Preload (acc. to Preload force  $F_{pr}$  table)

#### Key to illustration

$\delta_{et}$  = Elastic deformation ( $\mu\text{m}$ )  
 $F$  = Load (N)

**Rigidity of Roller Rail System for preload C3  
Heavy-duty roller runner blocks FXS R1854**

Roller runner block mounted with

- ▶ 4 screws, strength class 12.9
- ▶ 2 screws, strength class 8.8

**Down load**

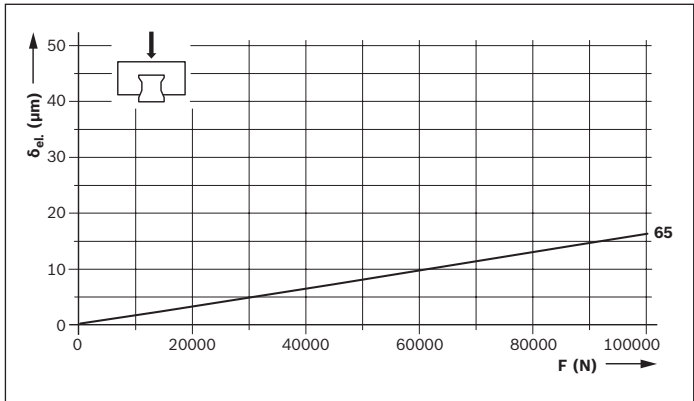

**Lift-off load**

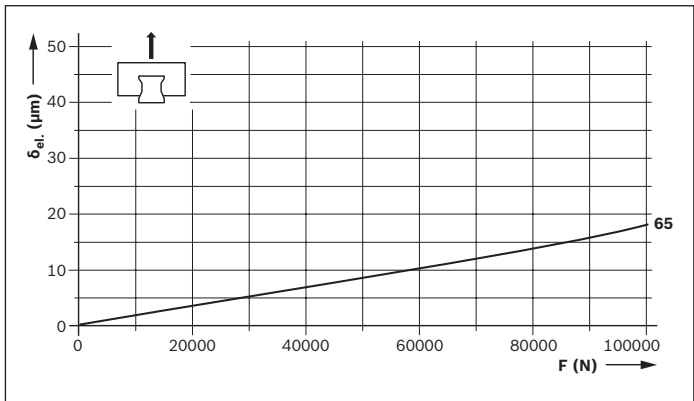

**Side load**

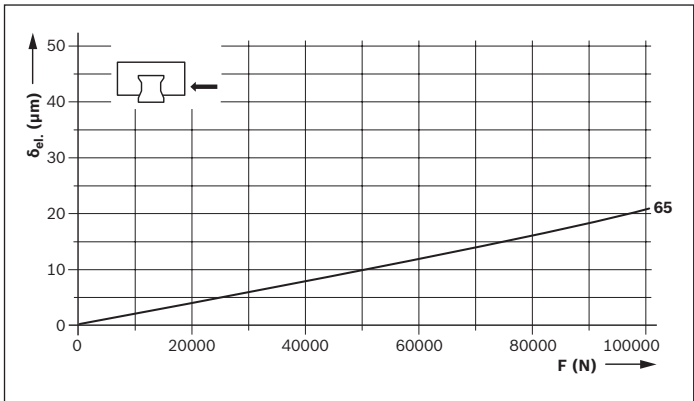

**Preload class**

C3 = Preload (acc. to Preload force F<sub>pr</sub> table)

**Key to illustration**

δ<sub>el.</sub> = Elastic deformation (μm)  
F = Load (N)

# Accuracy classes

## Accuracy classes and their tolerances for Standard Roller Rail Systems

Up to five accuracy classes apply to Standard Roller Rail Systems.

Up to three accuracy classes apply to heavy-duty roller rail systems.

For details on the available roller runner block and roller guide rails, please refer to the table with "material numbers".

### Precision manufacturing process makes interchangeability easy

Rexroth manufactures its roller guide rails and roller runner blocks with such high precision, especially in the roller track zone, that each individual component element is fully interchangeable.

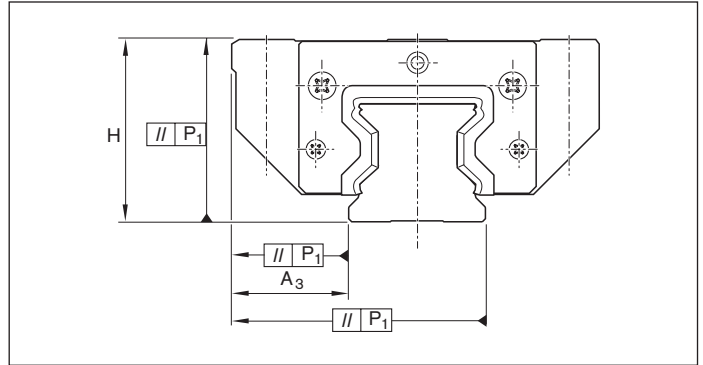

For example, a roller runner block may be used without any problems on various roller guide rails of the same size. Similarly, different roller runner blocks may also be used on one and the same roller guide rail.

Designation	Definition	Figure	Example H
$\Delta H_{abs}$	Tolerance of dimension H measured in middle of runner block for any combination of runner blocks and guide rails over the entire rail length	<p>The diagram shows a perspective view of a roller guide rail with several roller runner blocks. Blue arrows point upwards from the top surface of the roller blocks, indicating the measurement of dimension H. The arrows are distributed across the entire length of the rail.</p>	$\pm 40\mu m$
$\Delta H_{rel}$	Maximum difference in dimension H measured in middle of runner block for different runner blocks at the same rail position	<p>The diagram shows a perspective view of a roller guide rail with several roller runner blocks. Blue arrows point upwards from the top surface of the roller blocks at a specific position along the rail. Dashed lines and arrows indicate the comparison of dimension H between different blocks at that same position.</p>	$15\mu m$

Designation	Definition	Figure	Example H
$\Delta A_{3 abs}$	Tolerance of dimension A3 measured in middle of runner block for any combination of runner blocks and guide rails over the entire rail length	<p>The diagram shows a perspective view of a roller guide rail with several roller runner blocks. Blue arrows point horizontally from the side of the roller blocks, indicating the measurement of dimension A3. The arrows are distributed across the entire length of the rail.</p>	$\pm 20\mu m$
$\Delta A_{3 rel}$	Maximum difference in dimension A3 measured in middle of runner block for different runner blocks at the same rail position	<p>The diagram shows a perspective view of a roller guide rail with several roller runner blocks. Blue arrows point horizontally from the side of the roller blocks at a specific position along the rail. Dashed lines and arrows indicate the comparison of dimension A3 between different blocks at that same position.</p>	$15\mu m$

**Standard and heavy-duty roller rail system made of steel**

Accuracy classes	Tolerances of the dimensions ( $\mu\text{m}$ )		$\Delta H_{rel}$	$\Delta A_{3 rel}$
	$\Delta H_{abs}$	$\Delta A_{3 abs}$		
<b>H</b>	$\pm 40$	$\pm 20$		15
<b>P</b>	$\pm 20$	$\pm 10$		7
<b>SP</b>	$\pm 10$	$\pm 7$		5
<b>GP<sup>1)</sup></b>	( $\pm 10$ ) 10	$\pm 7$		5
<b>UP</b>	$\pm 5$	$\pm 5$		3

1) Dimension H: ( $\pm 10$ ) sorted by height (GP) to 10  $\mu\text{m}$  (see "Combination of accuracy classes")

**Standard and heavy-duty roller guide rails Resist CR, hard chrome plated**

Accuracy classes	Tolerances of the dimensions ( $\mu\text{m}$ )				$\Delta H_{rel}$	$\Delta A_{3 rel}$
	$\Delta H_{abs}$		$\Delta A_{3 abs}$			
	RW/RS	RS	RW/RS	RS		
<b>H</b>	+47 -38	+44 -39	$\pm 23$	+19 24	18	15
<b>P</b>	+27 -18	+24 -19	$\pm 13$	+9 -14	10	7
<b>SP</b>	+17 -8	+14 -9	$\pm 10$	+6 -11	8	5

### Parallelism offset $P_1$ of the roller rail system in operation

Values measured in middle of runner block with roller rail systems without surface coating.

For hard chrome plated roller guide rails, the values can increase up to 2  $\mu\text{m}$ .

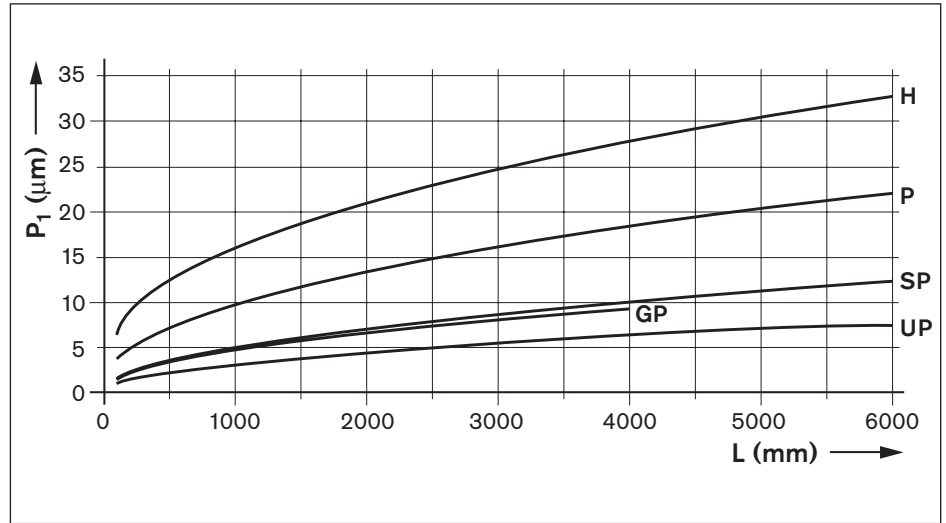

#### Key to illustration

$P_1$  = Parallelism offset ( $\mu\text{m}$ )  
 L = Rail length (mm)

### Combinations of accuracy classes

#### Tolerances for combination of accuracy classes

Accuracy classes, roller runner blocks	Tolerances of the dimensions ( $\mu\text{m}$ )	Accuracy classes for roller guide rails				
		H	P	SP	GP	UP
<b>H</b>	$\Delta H_{\text{abs}}$	$\pm 40$	$\pm 24$	$\pm 15$	$\pm 10$	$\pm 11$
	$\Delta A_{3 \text{ abs}}$	$\pm 20$	$\pm 14$	$\pm 12$	$\pm 12$	$\pm 11$
	$\Delta H_{\text{rel}}, \Delta A_{3 \text{ rel}}$	15	15	15	15	15
<b>P</b>	$\Delta H_{\text{abs}}$	$\pm 36$	$\pm 20$	$\pm 11$	$\pm 6$	$\pm 7$
	$\Delta A_{3 \text{ abs}}$	$\pm 16$	$\pm 10$	$\pm 8$	$\pm 8$	$\pm 7$
	$\Delta H_{\text{rel}}, \Delta A_{3 \text{ rel}}$	7	7	7	7	7
<b>SP</b>	$\Delta H_{\text{abs}}$	$\pm 35$	$\pm 19$	$\pm 10$	$(\pm 10)^1 \pm 5$	$\pm 6$
	$\Delta A_{3 \text{ abs}}$	$\pm 15$	$\pm 9$	$\pm 7$	$\pm 7$	$\pm 6$
	$\Delta H_{\text{rel}}, \Delta A_{3 \text{ rel}}$	5	5	5	5	5
<b>UP</b>	$\Delta H_{\text{abs}}$	$\pm 34$	$\pm 18$	$\pm 9$	$\pm 4$	$\pm 5$
	$\Delta A_{3 \text{ abs}}$	$\pm 14$	$\pm 8$	$\pm 6$	$\pm 6$	$\pm 5$
	$\Delta H_{\text{rel}}, \Delta A_{3 \text{ rel}}$	3	3	3	3	3

1) Dimension H: ( $\pm 10$ ) sorted by height (GP) to 10  $\mu\text{m}$  (see "Combination: SP roller runner block with GP roller guide rails")

**Combination: SP roller runner block with GP roller guide rails**

Dimension H: ( $\pm 10$ ) sorted by height (GP) to  $\pm 5 \dots 10 \mu\text{m}$ : **Valid** with an arbitrary combination of roller runner blocks of accuracy class SP and roller guide rails R1805 .68 .. with the same sorting, e.g.  $-1^{\pm 2.5} \mu\text{m}$ , over the total rail length. Sorting markings on the roller guide rail and the additional label, e.g. GP-1, GP +3 etc. Indicate the number of pieces per sorting with your order, e.g. 2 pieces per sorting.

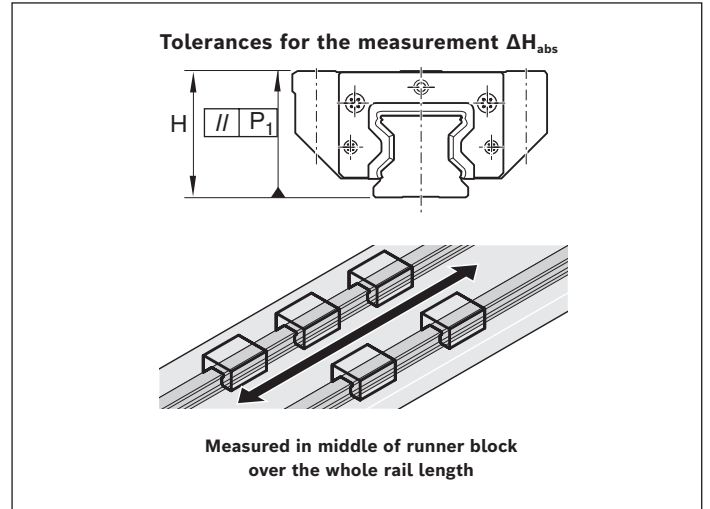

**Height sorting of roller guide rails**

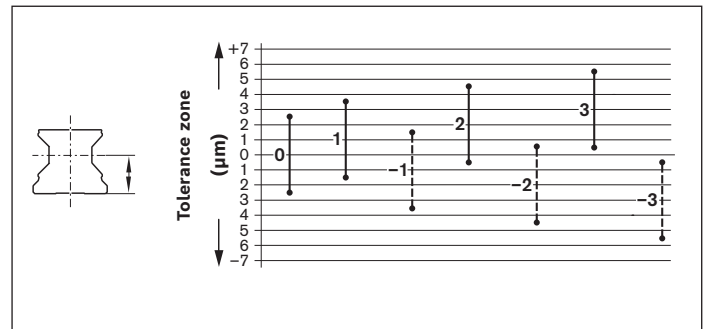

**Recommendations for combining accuracy classes**

Recommended with **small roller runner block distances** and short strokes:  
Roller **runner block** in **higher** accuracy class than roller guide rail.

Recommended with **relatively large roller runner block distances** and long strokes:  
Roller **guide rail** in **higher** accuracy class than roller runner block.

**Travel accuracy**

By means of perfectly optimized roller entry and roller exit zones in the roller runner block and the optimized screw-on partition in the roller guide rails, a very high travel accuracy with the lowest pulsation is achieved.

Particularly suitable for highly precise, chipping machining, measuring technology, high-precision scanners, eroding technology etc.

# Preload

## Definition of preload class

Preload force, based on the dynamic load capacity rating C of the particular roller runner block.

## Selection of the preload class

Code	Application area
<b>C1</b> <b>C4</b> <b>C5</b>	Customization upon request
<b>C2</b>	For guide systems with both high external loading and high demands on overall rigidity; also recommended for single-rail systems. Above average moment loads can be absorbed without significant elastic deformation. Further improved overall rigidity with only medium moment loads.
<b>C3</b>	For highly rigid guide systems, e.g. precision tooling machines etc. Above-average loads and moments are caught with the lowest possible elastic deformation. roller runner block with preload C3 only available in the accuracy classes P, SP (GP) and UP.

## Preload force $F_{pr}$

Roller runner block			Size	25	35	45	55	65	100	125
		Format	Preload class	Preload force $F_{pr}$ (N)						
Standard roller runner block made of steel <sup>1)</sup> and Resist CR <sup>2)</sup>	R1851 R1822 R1821 R1861	FNS SNS SNH	C1	830	1680	2930	3860	6520		
			C2	2240	4510	7890	10400	17600	36900	60600
			C3	3640	7320	12800	16800	28500	59900	98400
			C4	4770	9610	16800	22100	37400		
			C5	5610	11300	19700	26000	43900		
	R1853 R1823 R1824 R1863	FLS SLS SLH	C1	1010	2060	3640	4790	8140		
			C2	2720	5540	9790	12900	21900	50600	81600
			C3	4420	8990	15900	20900	35500	82200	132600
			C4	5800	11800	20800	27400	46600		
			C5	6810	13900	24500	32200	54700		
Roller runner block made of steel <sup>1)</sup>	R1854	FXS	C2					29300		
			C3					47700		

1) All steel parts made of carbon steel

2) Roller runner block body made of steel with low-corrosion coating, matte silver, hard chrome plated

**Recommended combination based on preload and accuracy class of roller runner block and roller guide rail**

Recommendation for preload C2:  
Accuracy classes H and P

Recommendation for preload C3:  
Accuracy classes P, SP, GP and UP

**Combination of hard chrome plated roller runner block with hard chrome plated roller guide rails**

When hard chrome plated roller runner blocks with preload C2 and/or C3 are combined with hard chrome plated roller guide rails, the preload is increased by approx. half a preload class.

# Product description

## Characteristic features

- ▶ Roller runner blocks RSHP are suitable for all typical applications as well as for special installation and environmental conditions and conditions of use, so that additional special designs are not necessary.
- ▶ High torque load capacity
- ▶ Same high load capacity in all four main directions of loading
- ▶ Maximum rigidity in all directions of loading due to additional screw connections on two bores in the center of the roller runner block
- ▶ Limitless interchangeability
- ▶ All roller guide rail versions can be combined arbitrarily with all roller runner block versions
- ▶ Accessories can be screwed down to the end face of the roller runner block

## Optional versions

- ▶ Low-corrosion roller runner blocks and roller guide rails Resist CR, hard chrome plated, available in accuracy class H. Accuracy classes P and SP available upon request.
- ▶ Sizes 25 and 65
- ▶ Preload classes C1 to C5
- ▶ Version with seal DS, SS, LS or AS

## Further highlights

- ▶ Lube nipples possible on all sides for easy maintenance
- ▶ Low lubrication quantities thanks to innovative channel design
- ▶ Quiet running thanks to optimally designed roller return and guideway
- ▶ Attachments on the roller runner block can be mounted from above and below
- ▶ Maximum rigidity in all directions of loading due to additional screw connections on two bores in the center of the roller runner block
- ▶ High torque load capacity
- ▶ Lowest elastic deflection and greatest precision in the travel performance due to the further optimized entry-zone geometry and high number of rollers
- ▶ The roller runner block is simply slid onto the rail with the transport lock
- ▶ Integrated all-round sealing as standard

## Identification system of material numbers

Material number	Example:	R	18	51	3	2	1	2A
<b>Rolling element</b>	=	Roller =	<b>18</b>					
<b>Format</b>	=	FNS =	<b>51</b>	FLS = 53 / SNS = 22 / SLS = 23 / SNH = 21 / SLH = 24				
<b>Size</b>	=	25 /	<b>35</b>	45 / 55 / 65				
<b>Preload</b>	=	C1 /	<b>C2</b>	C3 / C4 / C5				
<b>Accuracy class</b>	=	H = 3 / P = 2 /	<b>SP = 1</b>	UP = 9				
<b>Seal</b>	=	DS = 2X		SS = 24				
		LS = 25		<b>AS = 2A</b>				

## Formats of High-Precision Roller runner blocks

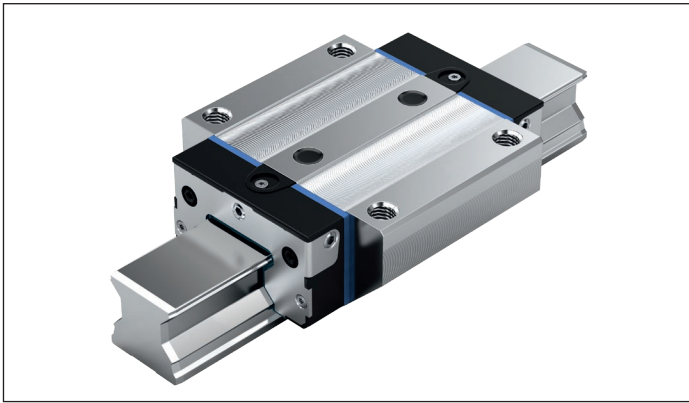

**FNS** – Flanged, normal, standard height

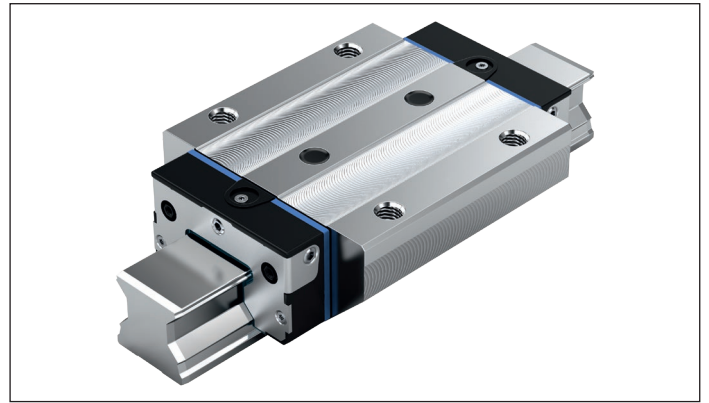

**FLS** – Flanged, long, standard height

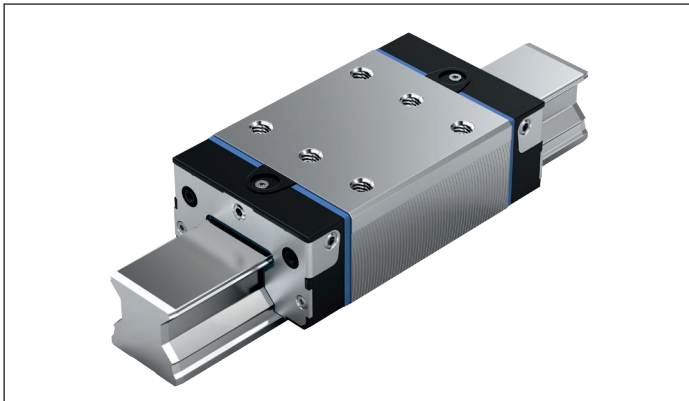

**SNS** – Slimline, normal, standard height

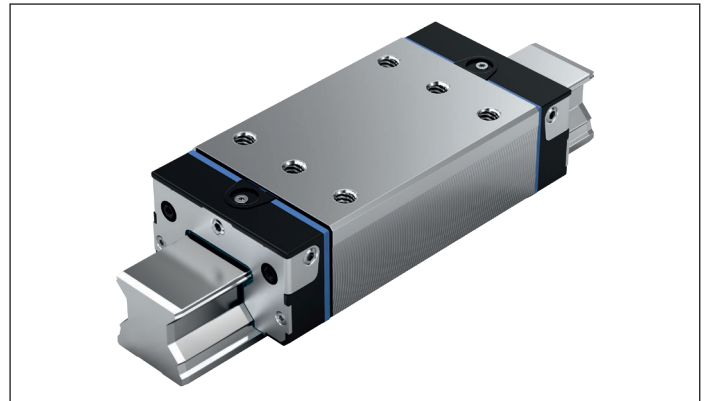

**SLS** – Slimline, long, standard height

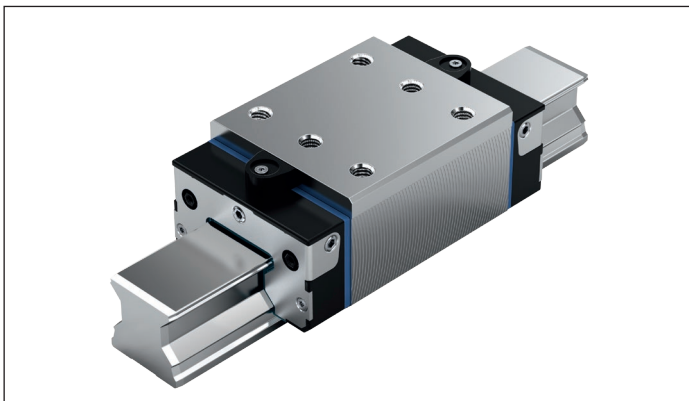

**SNH** – Slimline, normal, high



**SLH** – Slimline, long, high

# FNS – flanged, normal, standard height

## R1851 ... 2.

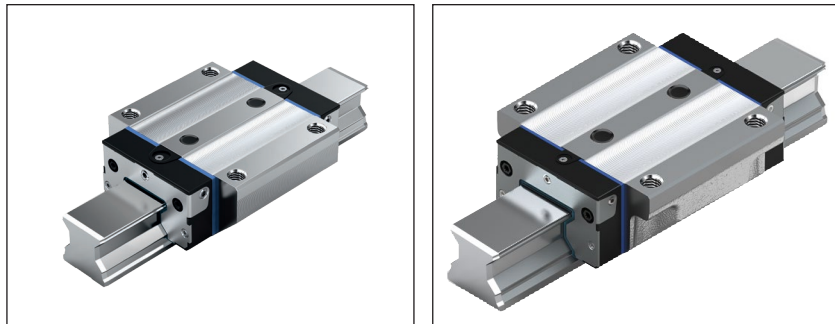

### Dynamic characteristics

Travel speed:  $v_{\max} = 4 \text{ m/s}$

Acceleration:  $a_{\max} = 150 \text{ m/s}^2$

### Recommended combination based on preload and accuracy class

- ▶ For preload C2: H and P (preferably)
- ▶ For preload C3: P and SP

### Material numbers

Size	Roller runner block with size	Preload class		Accuracy class				Seals			
		C2	C3	H	P	SP	UP	DS	LS	SS	AS <sup>1)</sup>
25	R1851 2	2		3	2	1	9	2X	–	–	–
			3		2	1	9	2X	–	–	–
35	R1851 3	2		3	2	1	9	2X	25	24	2A
			3		2	1	9	2X	25	24	2A
45	R1851 4	2		3	2	1	9	2X	25	24	2A
			3		2	1	9	2X	25	24	2A
55	R1851 5	2		3	2	1	9	2X	–	–	2A
			3		2	1	9	2X	–	–	2A
65	R1851 6	2		3	2	1	9	2X	–	–	–
			3		2	1	9	2X	–	–	–

1) With integrated DS seal

### Technical data

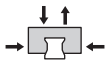
Size	Mass (kg)	Load capacities <sup>2)</sup> (N)		Torsional moment load capacity <sup>2)</sup> (Nm)		Longitudinal moment load capacity <sup>2)</sup> (Nm)	
			$C_0$	$M_t$	$M_{t0}$	$M_L$	$M_{L0}$
25	0.73	26900	59500	348	770	260	580
35	2.15	61000	119400	1210	2370	760	1480
45	4.05	106600	209400	2640	5180	1650	3240
55	5.44	140400	284700	4120	8350	2610	5290
65	10.72	237200	456300	8430	16210	5260	10120

2) Determination of the dynamic load capacities and load moments is based on a travel of 100,000 m according to DIN ISO 14728-1. Often only 50,000 m are actually stipulated. For comparison: Multiply values C,  $M_t$  and  $M_L$  from the table by 1.23.

### Ordering example

Options:

- ▶ Roller runner block FNS
- ▶ Size 35
- ▶ Preload class C2
- ▶ Accuracy class H
- ▶ With double-lip seal 2X

Material number: R1851 323 2X

### Preload classes

C2 = Average preload  
 C3 = High preload  
 C1, C4, C5 upon request

### Seals

DS = Double-lip seal  
 LS = Low-friction seal  
 SS = Standard seal  
 AS = Longitudinal seal

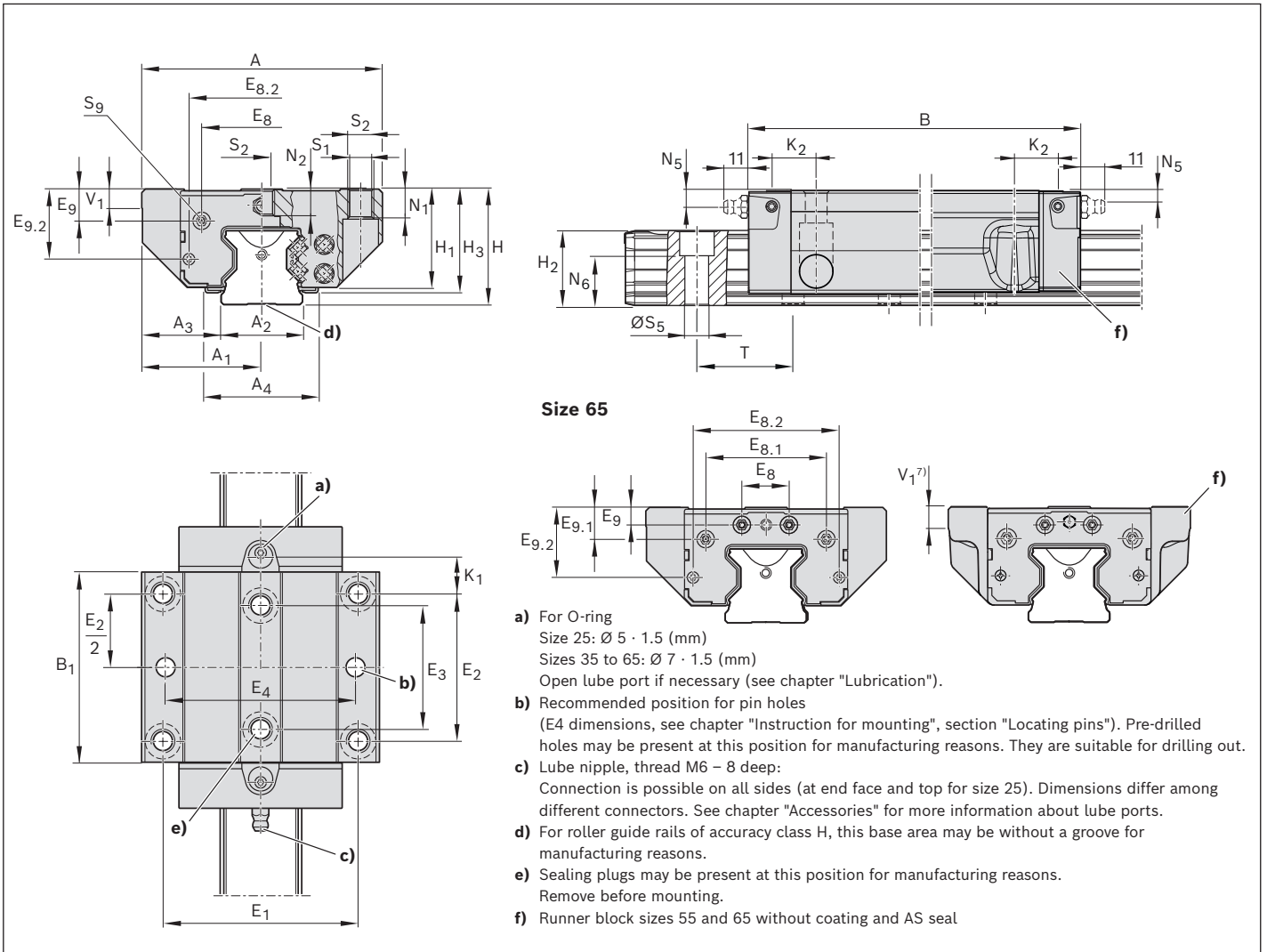

**Dimensions (mm)**

Size	A	A <sub>1</sub>	A <sub>2</sub>	A <sub>3</sub>	A <sub>4</sub> <sup>1)</sup>	B	B <sub>1</sub>	E <sub>1</sub>	E <sub>2</sub>	E <sub>3</sub>	E <sub>4</sub>	E <sub>8</sub>	E <sub>8.1</sub>	E <sub>8.2</sub>	E <sub>9</sub>	E <sub>9.1</sub>	E <sub>9.2</sub>
25	70	35	23	23.5	–	97.00	63.5	57	45	40	55	33.4	–	40.2	8.30	–	21.40
35	100	50	34	33.0	47.0	118.00	79.6	82	62	52	80	50.3	–	60.5	13.10	–	29.10
45	120	60	45	37.5	55.6	147.00	101.5	100	80	60	98	62.9	–	72.0	16.70	–	36.50
55	140	70	53	43.5	63.3	170.65	123.1	116	95	70	114	74.2	–	81.6	18.85	–	40.75
65	170	85	63	53.5	–	207.30	146.0	142	110	82	140	35.0	93	106.0	9.30	26	55.00

Size	H	H <sub>1</sub>	H <sub>2</sub> <sup>2)</sup>	H <sub>2</sub> <sup>3)</sup>	H <sub>3</sub> <sup>4)</sup>	K <sub>1</sub>	K <sub>2</sub>	N <sub>1</sub>	N <sub>2</sub>	N <sub>5</sub>	N <sub>6</sub> <sup>±0.5</sup>	Ø S <sub>1</sub>	S <sub>2</sub>	S <sub>5</sub>	S <sub>9</sub> <sup>5)</sup>	T <sup>6)</sup>	V <sub>1</sub>	V <sub>1</sub> <sup>7)</sup>
25	36	30	23.60	23.40	–	14.05	–	9	7.3	5.5	14.3	6.7	M8	7	M3-6.5 deep	30.0	7.5	–
35	48	41	31.10	30.80	43	15.55	17.40	12	11.0	7.0	19.4	8.5	M10	9	M3-6.0 deep	40.0	8.0	–
45	60	51	39.10	38.80	53	17.45	20.35	15	13.5	8.0	22.4	10.4	M12	14	M4-9.0 deep	52.5	10.0	–
55	70	58	47.85	47.55	60	21.75	24.90	18	13.7	9.0	28.7	12.4	M14	16	M5-8.0 deep	60.0	12.0	12.6 <sub>+/-1.2</sub> <sup>7)</sup>
65	90	76	58.15	57.85	–	30.00	33.00	23	21.5	9.3	36.5	14.6	M16	18	M4-8.0 deep	75.0	15.0	15.6 <sub>+/-1.2</sub> <sup>7)</sup>

- 1) Dimension A<sub>4</sub> = Width of the additional longitudinal seal
- 2) Dimension H<sub>2</sub> with cover strip
- 3) Dimension H<sub>2</sub> without cover strip
- 4) Dimension H<sub>3</sub> = Total roller runner block including the additional longitudinal seal
- 5) Thread for connecting parts
- 6) Dimension T = Rail separation of the roller guide rail
- 7) Dimensions for runner block sizes 55 and 65 without coating and AS seal

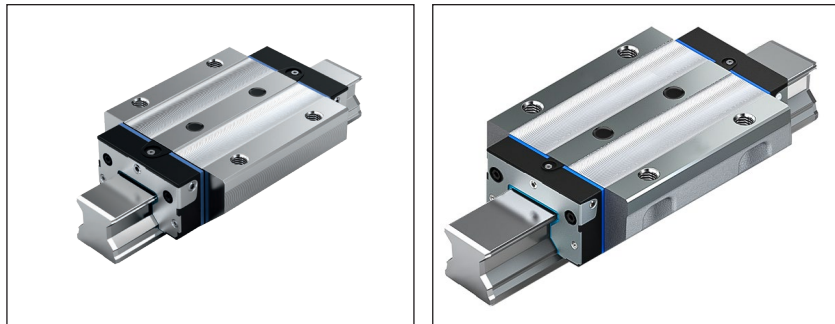
# FLS – flanged, long, standard height – R1853 ... 2.



### Dynamic characteristics

Travel speed:  $v_{\max} = 4 \text{ m/s}$

Acceleration:  $a_{\max} = 150 \text{ m/s}^2$

### Recommended combination based on preload and accuracy class

- ▶ For preload C2: H and P (preferably)
- ▶ For preload C3: P and SP

### Material numbers

Size	Roller runner block with size	Preload class		Accuracy class				Seals			
		C2	C3	H	P	SP	UP	DS	LS	SS	AS <sup>1)</sup>
25	R1853 2	2		3	2	1	9	2X	–	–	–
			3		2	1	9	2X	–	–	–
35	R1853 3	2		3	2	1	9	2X	25	24	2A
			3		2	1	9	2X	25	24	2A
45	R1853 4	2		3	2	1	9	2X	25	24	2A
			3		2	1	9	2X	25	24	2A
55	R1853 5	2		3	2	1	9	2X	–	–	2A
			3		2	1	9	2X	–	–	2A
65	R1853 6	2		3	2	1	9	2X	–	–	–
			3		2	1	9	2X	–	–	–

1) With integrated DS seal

### Technical data

Size	Mass (kg)	Load capacities <sup>2)</sup> (N)		Torsional moment load capacity <sup>2)</sup> (Nm)		Longitudinal moment load capacity <sup>2)</sup> (Nm)	
	<b>m</b>	<b>C</b>	<b>C<sub>0</sub></b>	<b>M<sub>t</sub></b>	<b>M<sub>t0</sub></b>	<b>M<sub>L</sub></b>	<b>M<sub>L0</sub></b>
25	0.93	33300	76400	432	990	420	970
35	2.70	74900	155400	1490	3080	1220	2530
45	5.15	132300	276400	3270	6830	2690	5630
55	7.15	174000	374900	5100	10990	4420	9520
65	14.18	295900	606300	10510	21540	8870	18180

2) Determination of the dynamic load capacities and load moments is based on a travel of 100,000 m according to DIN ISO 14728-1. Often only 50,000 m are actually stipulated. For comparison: Multiply values C, M<sub>t</sub> and M<sub>L</sub> from the table by 1.23.

### Ordering example

Options:

- ▶ Roller runner block FLS
- ▶ Size 35
- ▶ Preload class C2
- ▶ Accuracy class H
- ▶ With double-lip seal 2X

Material number: R1853 323 2X

### Preload classes

- C2 = Average preload
- C3 = High preload
- C1, C4, C5 upon request

### Seals

- DS = Double-lip seal
- LS = Low-friction seal
- SS = Standard seal
- AS = Longitudinal seal

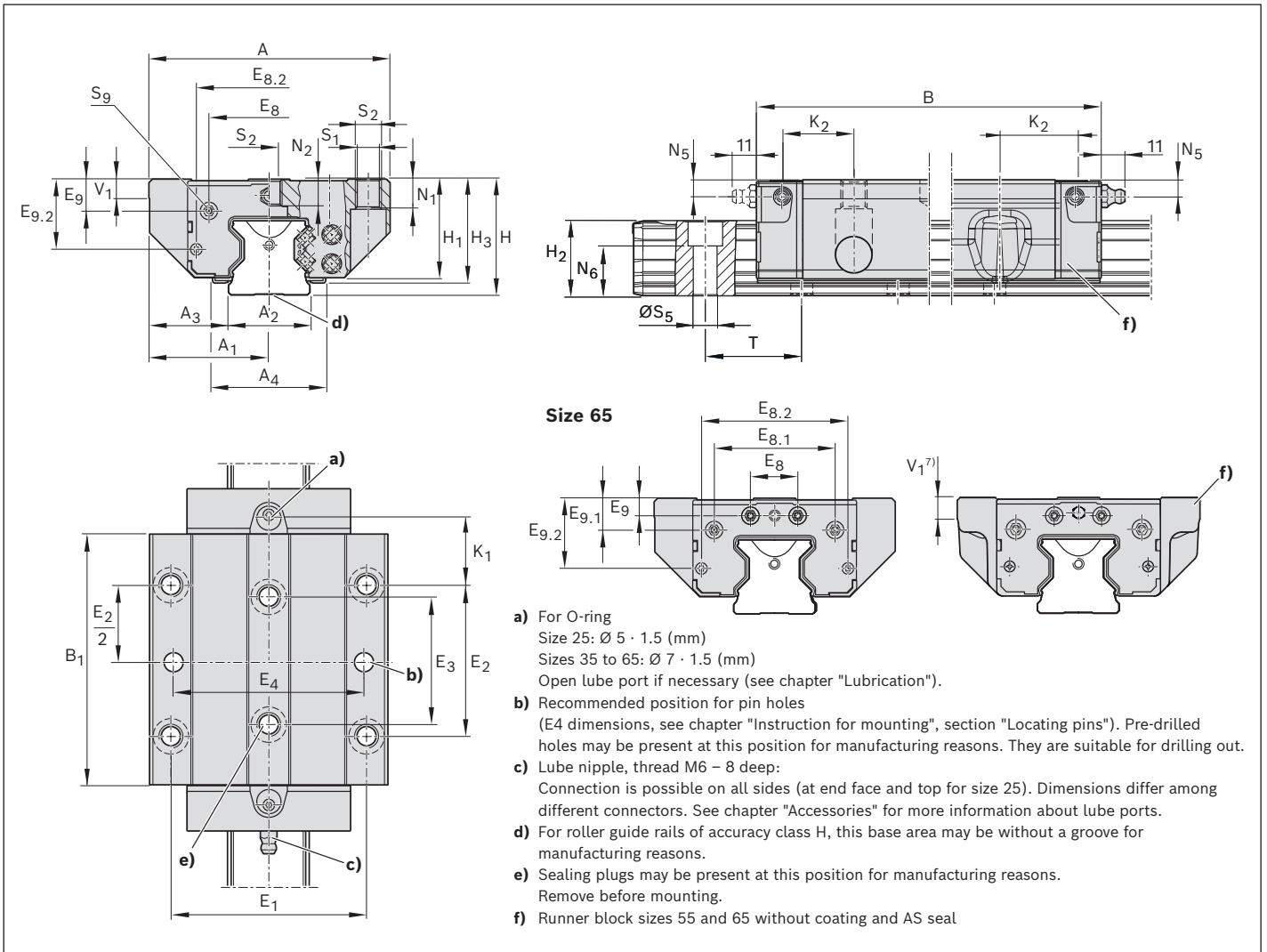

**Dimensions (mm)**

Size	A	A <sub>1</sub>	A <sub>2</sub>	A <sub>3</sub>	A <sub>4</sub> <sup>1)</sup>	B	B <sub>1</sub>	E <sub>1</sub>	E <sub>2</sub>	E <sub>3</sub>	E <sub>4</sub>	E <sub>8</sub>	E <sub>8.1</sub>	E <sub>8.2</sub>	E <sub>9</sub>	E <sub>9.1</sub>	E <sub>9.2</sub>
25	70	35	23	23.5	–	115.00	81.5	57	45	40	55	33.4	–	40.2	8.30	–	21.40
35	100	50	34	33.0	47.0	142.00	103.6	82	62	52	80	50.3	–	60.5	13.10	–	29.10
45	120	60	45	37.5	55.6	179.50	134.0	100	80	60	98	62.9	–	72.0	16.70	–	36.50
55	140	70	53	43.5	63.3	209.65	162.1	116	95	70	114	74.2	–	81.6	18.85	–	40.75
65	170	85	63	53.5	–	255.30	194.0	142	110	82	140	35.0	93.00	106.0	9.30	26.00	55.00

Size	H	H <sub>1</sub>	H <sub>2</sub> <sup>2)</sup>	H <sub>2</sub> <sup>3)</sup>	H <sub>3</sub> <sup>4)</sup>	K <sub>1</sub>	K <sub>2</sub>	N <sub>1</sub>	N <sub>2</sub>	N <sub>5</sub>	N <sub>6</sub> <sup>±0.5</sup>	Ø S <sub>1</sub>	S <sub>2</sub>	S <sub>5</sub>	S <sub>9</sub> <sup>5)</sup>	T <sup>6)</sup>	V <sub>1</sub>	V <sub>1</sub> <sup>7)</sup>
25	36	30	23.60	23.40	–	23.05	–	9	7.3	5.5	14.3	6.7	M8	7	M3-6.5 deep	30.0	7.5	–
35	48	41	31.10	30.80	43	27.55	29.40	12	11.0	7.0	19.4	8.5	M10	9	M3-6.0 deep	40.0	8.0	–
45	60	51	39.10	38.80	53	33.70	36.60	15	13.5	8.0	22.4	10.4	M12	14	M4-9.0 deep	52.5	10.0	–
55	70	58	47.85	47.55	60	41.25	44.40	18	13.7	9.0	28.7	12.4	M14	16	M5-8.0 deep	60.0	12.0	12.6 <sub>+/-1.2</sub> <sup>7)</sup>
65	90	76	58.15	57.85	–	54.00	57.00	23	21.5	9.3	36.5	14.6	M16	18	M4-8.0 deep	75.0	15.0	15.6 <sub>+/-1.2</sub> <sup>7)</sup>

- 1) Dimension A<sub>4</sub> = Width of the additional longitudinal seal
- 2) Dimension H<sub>2</sub> with cover strip
- 3) Dimension H<sub>2</sub> without cover strip
- 4) Dimension H<sub>3</sub> = Total roller runner block including the additional longitudinal seal
- 5) Thread for connecting parts
- 6) Dimension T = Rail separation of the roller guide rail
- 7) Dimensions for runner block sizes 55 and 65 without coating and AS seal

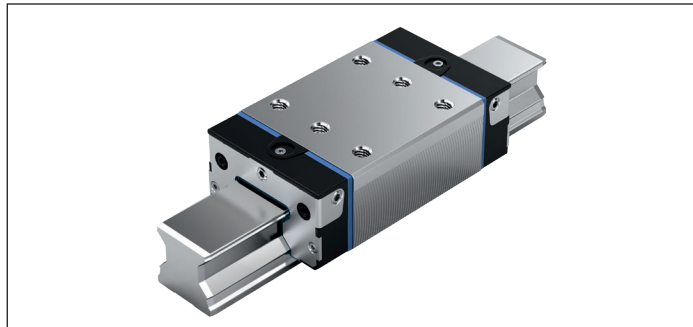
# SNS – slimline, normal, standard height – R1822 ... 2.



### Dynamic characteristics

Travel speed:  $v_{\max} = 4 \text{ m/s}$

Acceleration:  $a_{\max} = 150 \text{ m/s}^2$

### Recommended combination based on preload and accuracy class

- ▶ For preload C2: H and P (preferably)
- ▶ For preload C3: P and SP

### Material numbers

Size	Roller runner block with size	Preload class		Accuracy class				Seals			
		C2	C3	H	P	SP	UP	DS	LS	SS	AS <sup>1)</sup>
25	R1822 2	2		3	2	1	9	2X	–	–	–
			3		2	1	9	2X	–	–	–
35	R1822 3	2		3	2	1	9	2X	25	24	2A
			3		2	1	9	2X	25	24	2A
45	R1822 4	2		3	2	1	9	2X	25	24	2A
			3		2	1	9	2X	25	24	2A
55	R1822 5	2		3	2	1	9	2X	–	–	2A
			3		2	1	9	2X	–	–	2A
65	R1822 6	2		3	2	1	9	2X	–	–	–
			3		2	1	9	2X	–	–	–

1) With integrated DS seal

### Technical data

Size	Mass (kg)	Load capacities <sup>2)</sup> (N)		Torsional moment load capacity <sup>2)</sup> (Nm)		Longitudinal moment load capacity <sup>2)</sup> (Nm)	
		C	C <sub>0</sub>	M <sub>t</sub>	M <sub>t0</sub>	M <sub>L</sub>	M <sub>L0</sub>
25	0.54	26900	59500	348	770	260	580
35	1.55	61000	119400	1210	2370	760	1480
45	2.90	106600	209400	2640	5180	1650	3240
55	4.14	140400	284700	4120	8350	2610	5290
65	8.12	237200	456300	8430	16210	5260	10120

2) Determination of the dynamic load capacities and load moments is based on a travel of 100,000 m according to DIN ISO 14728-1. Often only 50,000 m are actually stipulated. For comparison: Multiply values C, M<sub>t</sub> and M<sub>L</sub> from the table by 1.23.

### Ordering example

Options:

- ▶ Roller runner block SNS
- ▶ Size 35
- ▶ Preload class C2
- ▶ Accuracy class H
- ▶ With double-lip seal 2X

Material number: R1822 323 2X

### Preload classes

C2 = Average preload  
C3 = High preload  
C1, C4, C5 upon request

### Seals

DS = Double-lip seal  
LS = Low-friction seal  
SS = Standard seal  
AS = Longitudinal seal

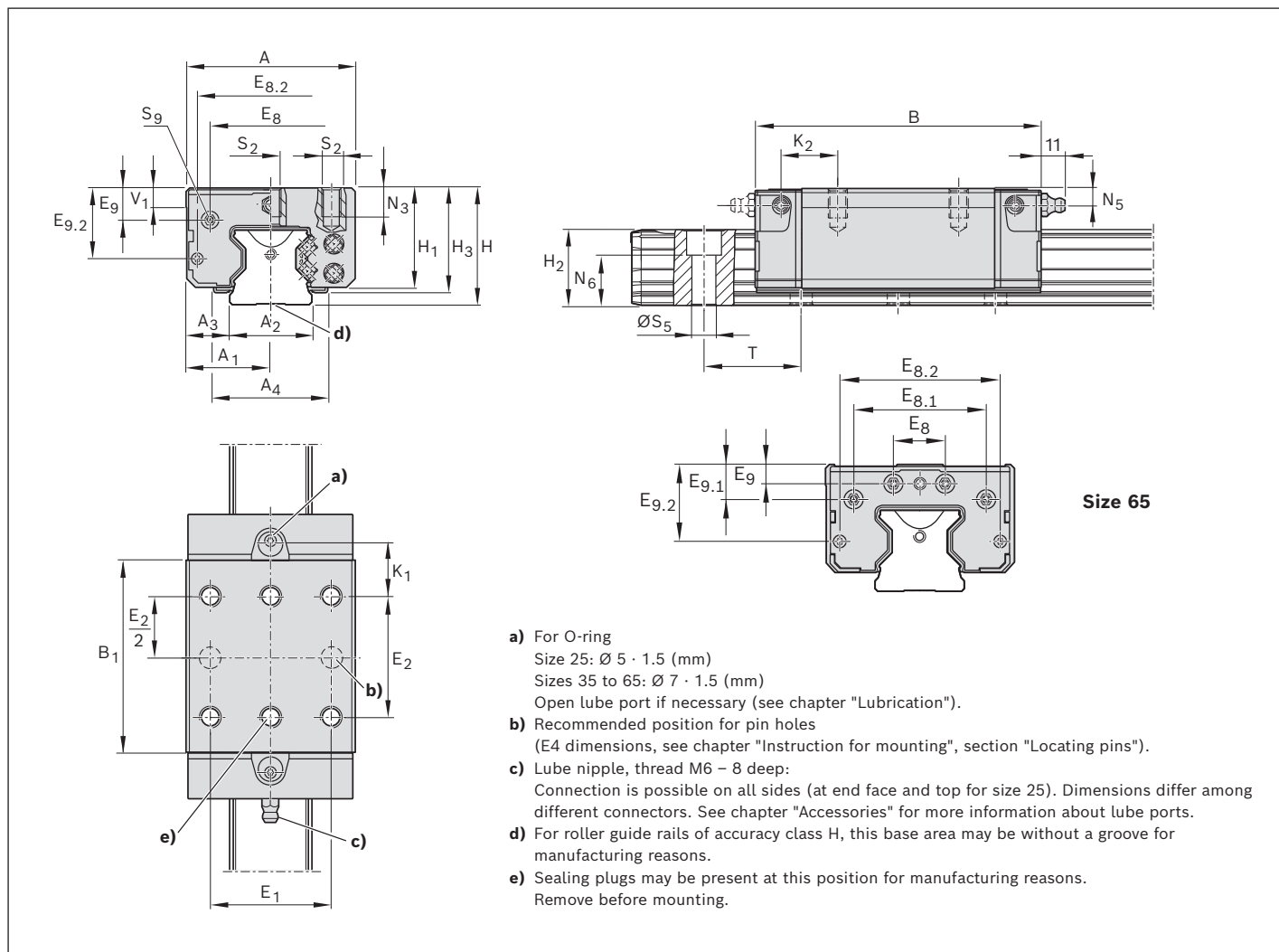

**Dimensions (mm)**

Size	A	A <sub>1</sub>	A <sub>2</sub>	A <sub>3</sub>	A <sub>4</sub> <sup>2)</sup>	B	B <sub>1</sub>	E <sub>1</sub>	E <sub>2</sub>	E <sub>8</sub>	E <sub>8.1</sub>	E <sub>8.2</sub>	E <sub>9</sub>	E <sub>9.1</sub>	E <sub>9.2</sub>
25	48	24	23	12.5	–	97.00	63.5	35	35	33.4	–	40.2	8.30	–	21.40
35	70	35	34	18.0	47.0	118.00	79.6	50	50	50.3	–	60.5	13.10	–	29.10
45	86	43	45	20.5	55.6	147.00	101.5	60	60	62.9	–	72.0	16.70	–	36.50
55	100	50	53	23.5	63.3	170.65	123.1	75	75	74.2	–	81.6	18.85	–	40.75
65	126	63	63	31.5	–	207.30	146.0	76	70	35.0	93.00	106.0	9.30	26.00	55.00

Size	H	H <sub>1</sub>	H <sub>2</sub> <sup>3)</sup>	H <sub>2</sub> <sup>4)</sup>	H <sub>3</sub> <sup>5)</sup>	K <sub>1</sub>	K <sub>2</sub>	N <sub>3</sub>	N <sub>5</sub>	N <sub>6</sub> <sup>20.5)</sup>	S <sub>2</sub>	S <sub>5</sub>	S <sub>9</sub> <sup>6)</sup>	T <sup>7)</sup>	V <sub>1</sub>
25	36	30	23.60	23.40	–	19.05	–	8	5.5	14.3	M6	7	M3-6.5 deep	30.0	7.5
35	48	41	31.10	30.80	43	21.55	23.40	12	7.0	19.4	M8	9	M3-6.0 deep	40.0	8.0
45	60	51	39.10	38.80	53	27.45	30.35	18	8.0	22.4	M10	14	M4-9.0 deep	52.5	10.0
55	70	58	47.85	47.55	60	31.75	34.90	17	9.0	28.7	M12	16	M5-8.0 deep	60.0	12.0
65	90	76	58.15	57.85	–	50.00	53.00	21	9.3	36.5	M16	18	M4-8.0 deep	75.0	15.0

- 1) Dimension A<sub>4</sub> = Width of the additional longitudinal seal
- 2) Dimension H<sub>2</sub> with cover strip
- 3) Dimension H<sub>2</sub> without cover strip
- 4) Dimension H<sub>3</sub> = Total roller runner block including the additional longitudinal seal
- 5) Thread for connecting parts
- 6) Dimension T = Rail separation of the roller guide rail

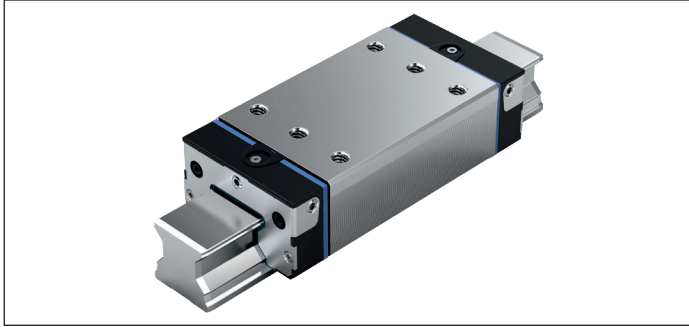
# SLS – slimline, long, standard height – R1823 ... 2.



### Dynamic characteristics

Travel speed:  $v_{\max} = 4 \text{ m/s}$

Acceleration:  $a_{\max} = 150 \text{ m/s}^2$

### Recommended combination based on preload and accuracy class



- ▶ For preload C2: H and P (preferably)
- ▶ For preload C3: P and SP

### Material numbers

Size	Roller runner block with size	Preload class		Accuracy class				Seals			
		C2	C3	H	P	SP	UP	DS	LS	SS	AS <sup>1)</sup>
25	R1823 2	2		3	2	1	9	2X	–	–	–
			3		2	1	9	2X	–	–	–
35	R1823 3	2		3	2	1	9	2X	25	24	2A
			3		2	1	9	2X	25	24	2A
45	R1823 4	2		3	2	1	9	2X	25	24	2A
			3		2	1	9	2X	25	24	2A
55	R1823 5	2		3	2	1	9	2X	–	–	2A
			3		2	1	9	2X	–	–	2A
65	R1823 6	2		3	2	1	9	2X	–	–	–
			3		2	1	9	2X	–	–	–

1) With integrated DS seal

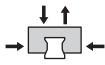
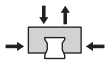
### Technical data

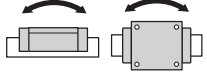
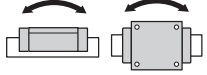
Size	Mass (kg)	Load capacities <sup>2)</sup> (N)		Torsional moment load capacity <sup>2)</sup> (Nm)		Longitudinal moment load capacity <sup>2)</sup> (Nm)	
							
	m	C	C <sub>0</sub>	M <sub>t</sub>	M <sub>t0</sub>	M <sub>L</sub>	M <sub>L0</sub>
25	0.68	33300	76400	432	990	420	970
35	1.95	74900	155400	1490	3080	1220	2530
45	3.65	132300	276400	3270	6830	2690	5630
55	5.30	174000	374900	5100	10990	4420	9520
65	10.68	295900	606300	10510	21540	8870	18180

2) Determination of the dynamic load capacities and load moments is based on a travel of 100,000 m according to DIN ISO 14728-1. Often only 50,000 m are actually stipulated. For comparison: Multiply values C, M<sub>t</sub> and M<sub>L</sub> from the table by 1.23.

### Ordering example

Options:

- ▶ Roller runner block SLS
- ▶ Size 35
- ▶ Preload class C2
- ▶ Accuracy class H
- ▶ With double-lip seal 2X

Material number: R1823 323 2X

### Preload classes

- C2 = Average preload
- C3 = High preload
- C1, C4, C5 upon request

### Seals

- DS = Double-lip seal
- LS = Low-friction seal
- SS = Standard seal
- AS = Longitudinal seal

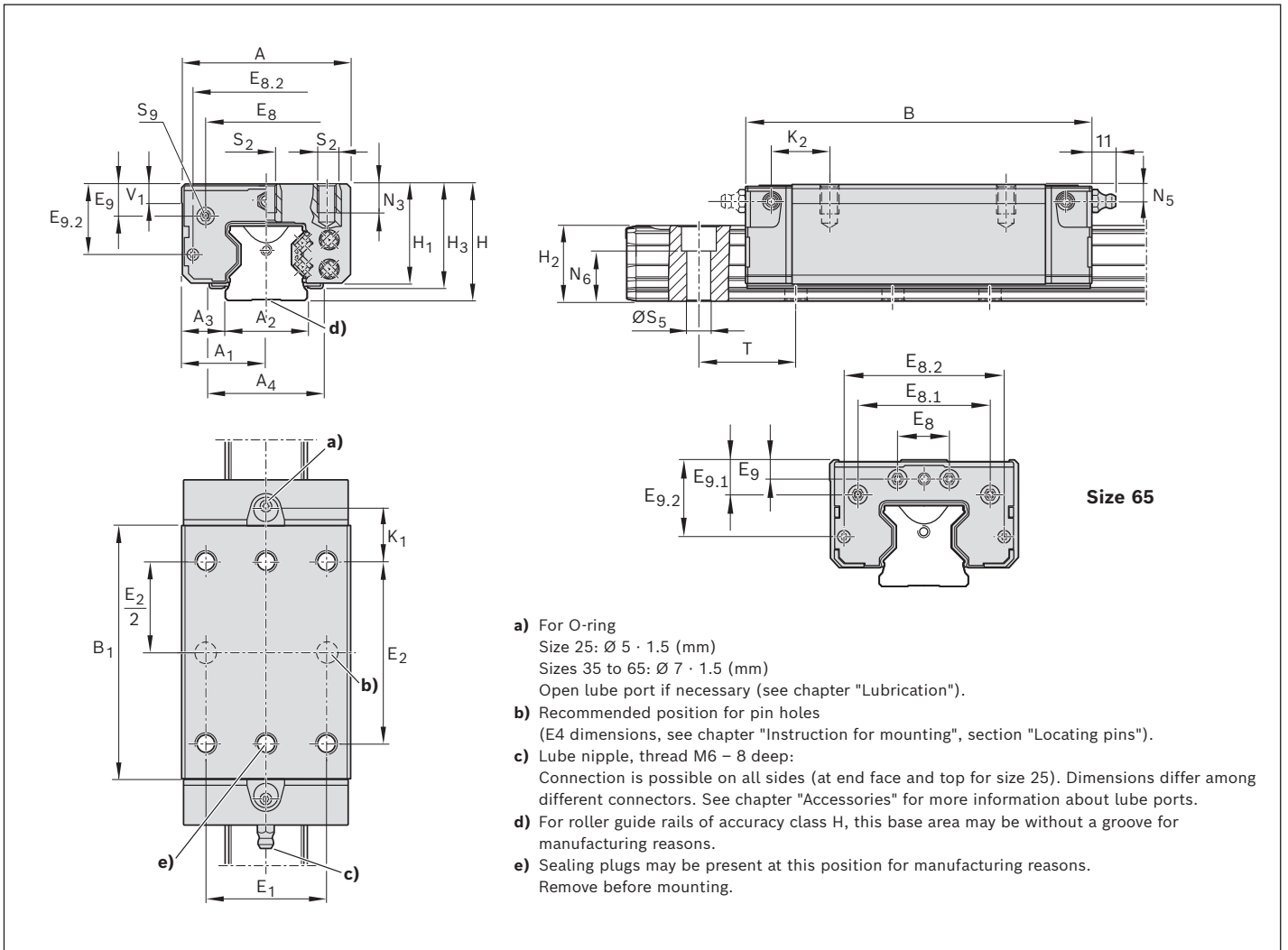

**Dimensions (mm)**

Size	A	A <sub>1</sub>	A <sub>2</sub>	A <sub>3</sub>	A <sub>4</sub> <sup>1)</sup>	B	B <sub>1</sub>	E <sub>1</sub>	E <sub>2</sub>	E <sub>8</sub>	E <sub>8.1</sub>	E <sub>8.2</sub>	E <sub>9</sub>	E <sub>9.1</sub>	E <sub>9.2</sub>
25	48	24	23	12.5	–	115.00	81.5	35	50	33.4	–	40.2	8.30	–	21.40
35	70	35	34	18.0	47.0	142.00	103.6	50	72	50.3	–	60.5	13.10	–	29.10
45	86	43	45	20.5	55.6	179.50	134.0	60	80	62.9	–	72.0	16.70	–	36.50
55	100	50	53	23.5	63.3	209.65	162.1	75	95	74.2	–	81.6	18.85	–	40.75
65	126	63	63	31.5	–	255.30	194.0	76	120	35.0	93.00	106.0	9.30	26.00	55.00

Size	H	H <sub>1</sub>	H <sub>2</sub> <sup>2)</sup>	H <sub>2</sub> <sup>3)</sup>	H <sub>3</sub> <sup>4)</sup>	K <sub>1</sub>	K <sub>2</sub>	N <sub>3</sub>	N <sub>5</sub>	N <sub>6</sub> <sup>±0.5</sup>	S <sub>2</sub>	S <sub>5</sub>	S <sub>9</sub> <sup>5)</sup>	T <sup>6)</sup>	V <sub>1</sub>
25	36	30	23.60	23.40	–	20.55	–	8	5.5	14.3	M6	7	M3-6.5 deep	30.0	7.5
35	48	41	31.10	30.80	43	22.55	24.40	12	7.0	19.4	M8	9	M3-6.0 deep	40.0	8.0
45	60	51	39.10	38.80	53	33.70	36.60	18	8.0	22.4	M10	14	M4-9.0 deep	52.5	10.0
55	70	58	47.85	47.55	60	41.25	44.40	17	9.0	28.7	M12	16	M5-8.0 deep	60.0	12.0
65	90	76	58.15	57.85	–	49.00	52.00	21	9.3	36.5	M16	18	M4-8.0 deep	75.0	15.0

- 1) Dimension A<sub>4</sub> = Width of the additional longitudinal seal
- 2) Dimension H<sub>2</sub> with cover strip
- 3) Dimension H<sub>2</sub> without cover strip
- 4) Dimension H<sub>3</sub> = Total roller runner block including the additional longitudinal seal
- 5) Thread for connecting parts
- 6) Dimension T = Rail separation of the roller guide rail

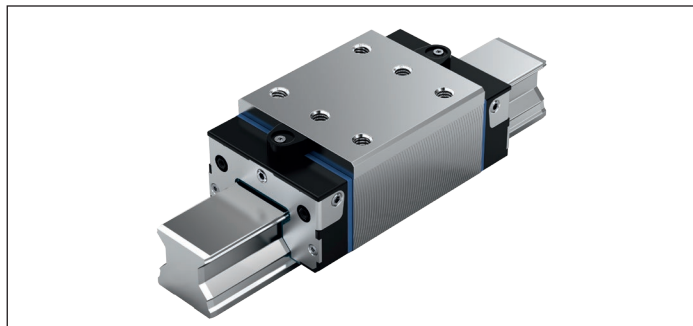
# SNH – slimline, normal, high – R1821 ... 2.



### Dynamic characteristics

Travel speed:  $v_{\max} = 4 \text{ m/s}$

Acceleration:  $a_{\max} = 150 \text{ m/s}^2$

### Recommended combination based on preload and accuracy class

- ▶ For preload C2: H and P (preferably)
- ▶ For preload C3: P and SP

### Material numbers

Size	Roller runner block with size	Preload class		Accuracy class				Seals			
		C2	C3	H	P	SP	UP	DS	LS	SS	AS <sup>1)</sup>
25	R1821 2	2		3	2	1	9	2X	–	–	–
			3		2	1	9	2X	–	–	–
35	R1821 3	2		3	2	1	9	2X	25	24	2A
			3		2	1	9	2X	25	24	2A
45	R1821 4	2		3	2	1	9	2X	25	24	2A
			3		2	1	9	2X	25	24	2A
55	R1821 5	2		3	2	1	9	2X	–	–	2A
			3		2	1	9	2X	–	–	2A

1) With integrated DS seal

### Technical data

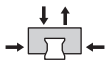
Size	Mass (kg)	Load capacities <sup>2)</sup> (N)		Torsional moment load capacity <sup>2)</sup> (Nm)		Longitudinal moment load capacity <sup>2)</sup> (Nm)	
			$C_o$	$M_t$	$M_{t0}$	$M_L$	$M_{L0}$
25	0.63	26900	59500	348	770	260	580
35	1.85	61000	119400	1210	2370	760	1480
45	3.35	106600	209400	2640	5180	1650	3240
55	5.04	140400	284700	4120	8350	2610	5290

2) Determination of the dynamic load capacities and load moments is based on a travel of 100,000 m according to DIN ISO 14728-1. Often only 50,000 m are actually stipulated. For comparison: Multiply values C,  $M_t$  and  $M_L$  from the table by 1.23.

### Ordering example

Options:

- ▶ Roller runner block SNH
- ▶ Size 35
- ▶ Preload class C2
- ▶ Accuracy class H
- ▶ With double-lip seal 2X

Material number: R1821 323 2X

### Preload classes

C2 = Average preload  
C3 = High preload  
C1, C4, C5 upon request

### Seals

DS = Double-lip seal  
LS = Low-friction seal  
SS = Standard seal  
AS = Longitudinal seal

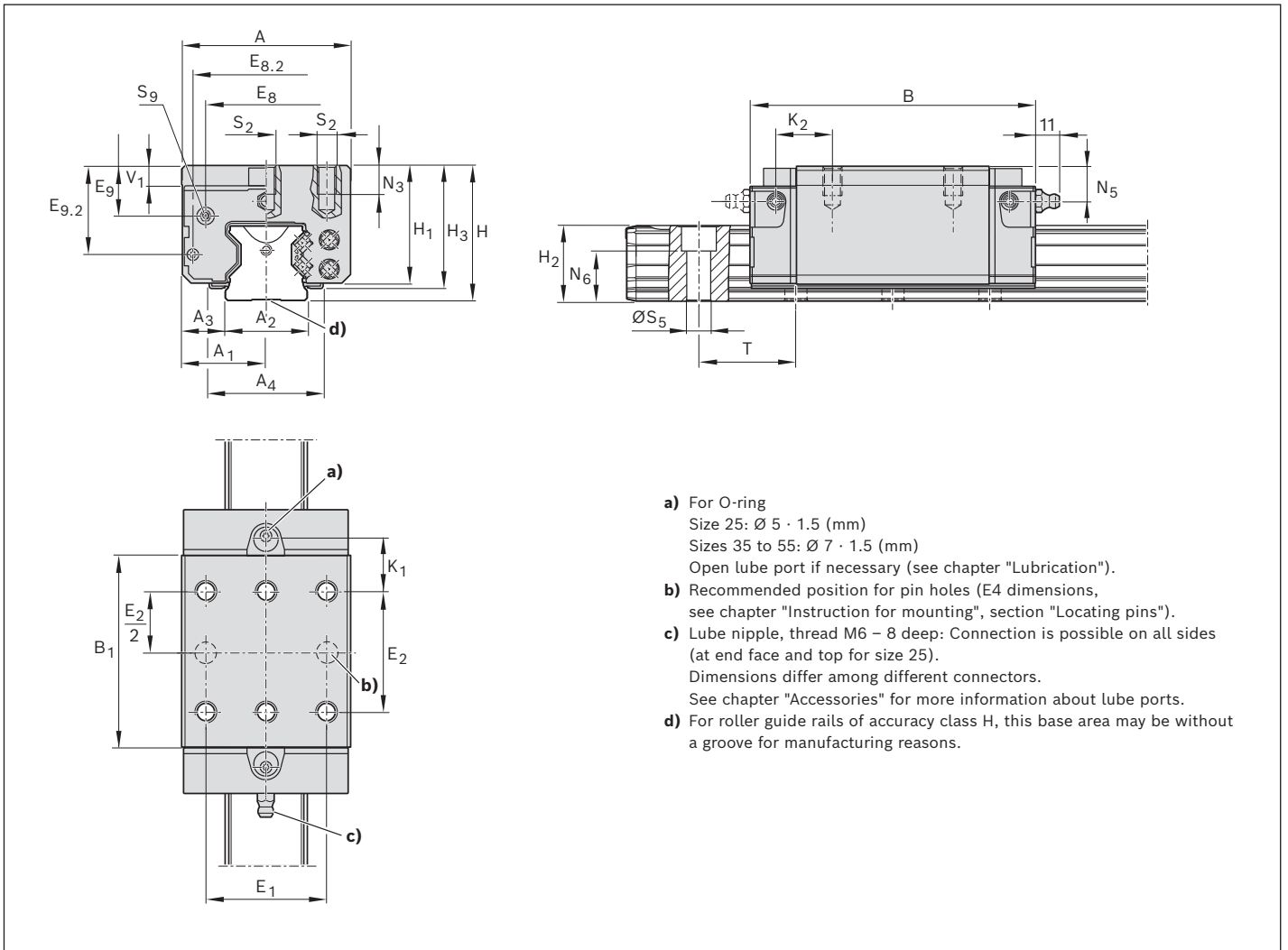

**Dimensions (mm)**

Size	A	A <sub>1</sub>	A <sub>2</sub>	A <sub>3</sub>	A <sub>4</sub> <sup>1)</sup>	B	B <sub>1</sub>	E <sub>1</sub>	E <sub>2</sub>	E <sub>8</sub>	E <sub>8.2</sub>	E <sub>9</sub>	E <sub>9.2</sub>
25	48	24	23	12.5	–	97.00	63.5	35	35	33.4	40.2	12.30	25.40
35	70	35	34	18.0	47.0	118.00	79.6	50	50	50.3	60.5	20.10	36.10
45	86	43	45	20.5	55.6	147.00	101.5	60	60	62.9	72.0	26.70	46.50
55	100	50	53	23.5	63.3	170.65	123.1	75	75	74.2	81.6	28.85	50.75

Size	H	H <sub>1</sub>	H <sub>2</sub> <sup>2)</sup>	H <sub>2</sub> <sup>3)</sup>	H <sub>3</sub> <sup>4)</sup>	K <sub>1</sub>	K <sub>2</sub>	N <sub>3</sub>	N <sub>5</sub>	N <sub>6</sub> <sup>±0.5</sup>	S <sub>2</sub>	S <sub>5</sub>	S <sub>9</sub> <sup>5)</sup>	T <sup>6)</sup>	V <sub>1</sub>
25	40	34	23.60	23.40	–	19.05	–	8	–	14.3	M6	7	M3-6.5 deep	30.0	7.5
35	55	48	31.10	30.80	50	21.55	23.40	13	14.0	19.4	M8	9	M3-6.0 deep	40.0	8.0
45	70	61	39.10	38.80	63	27.45	30.35	18	18.0	22.4	M10	14	M4-9.0 deep	52.5	10.0
55	80	68	47.85	47.55	70	31.75	34.90	19	19.0	28.7	M12	16	M5-8.0 deep	60.0	12.0

- 1) Dimension A<sub>4</sub> = Width of the additional longitudinal seal
- 2) Dimension H<sub>2</sub> with cover strip
- 3) Dimension H<sub>2</sub> without cover strip
- 4) Dimension H<sub>3</sub> = Total roller runner block including the additional longitudinal seal
- 5) Thread for connecting parts
- 6) Dimension T = Rail separation of the roller guide rail

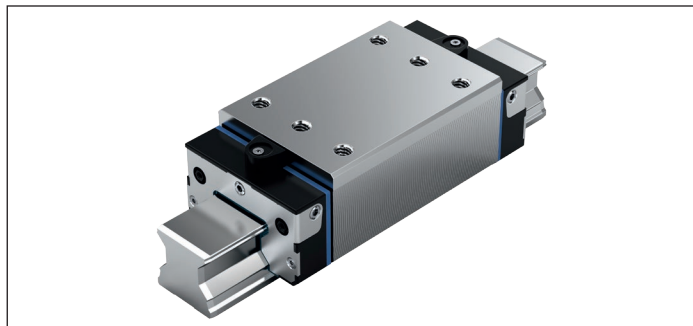
# SLH – slimline, long, high – R1824 ... 2.



### Dynamic characteristics

Travel speed:  $v_{\max} = 4 \text{ m/s}$

Acceleration:  $a_{\max} = 150 \text{ m/s}^2$

### Recommended combination based on preload and accuracy class

- ▶ For preload C2: H and P (preferably)
- ▶ For preload C3: P and SP

### Material numbers

Size	Roller runner block with size	Preload class		Accuracy class				Seals			
		C2	C3	H	P	SP	UP	DS	LS	SS	AS <sup>1)</sup>
25	R1824 2	2		3	2	1	9	2X	–	–	–
			3		2	1	9	2X	–	–	–
35	R1824 3	2		3	2	1	9	2X	25	24	2A
			3		2	1	9	2X	25	24	2A
45	R1824 4	2		3	2	1	9	2X	25	24	2A
			3		2	1	9	2X	25	24	2A
55	R1824 5	2		3	2	1	9	2X	–	–	2A
			3		2	1	9	2X	–	–	2A

1) With integrated DS seal

### Technical data

Size	Mass (kg)	Load capacities <sup>2)</sup> (N)		Torsional moment load capacity <sup>2)</sup> (Nm)		Longitudinal moment load capacity <sup>2)</sup> (Nm)	
		$C$	$C_0$	$M_t$	$M_{t0}$	$M_L$	$M_{L0}$
25	0.80	33300	76400	432	990	420	970
35	2.35	74900	155400	1490	3080	1220	2530
45	4.45	132300	276400	3270	6830	2690	5630
55	6.55	174000	374900	5100	10990	4420	9520

2) Determination of the dynamic load capacities and load moments is based on a travel of 100,000 m according to DIN ISO 14728-1. Often only 50,000 m are actually stipulated. For comparison: Multiply values  $C$ ,  $M_t$  and  $M_L$  from the table by 1.23.

### Ordering example

Options:

- ▶ Roller runner block SLH
- ▶ Size 35
- ▶ Preload class C2
- ▶ Accuracy class H
- ▶ With double-lip seal 2X

Material number: R1824 323 2X

### Preload classes

C2 = Average preload  
C3 = High preload  
C1, C4, C5 upon request

### Seals

DS = Double-lip seal  
LS = Low-friction seal  
SS = Standard seal  
AS = Longitudinal seal

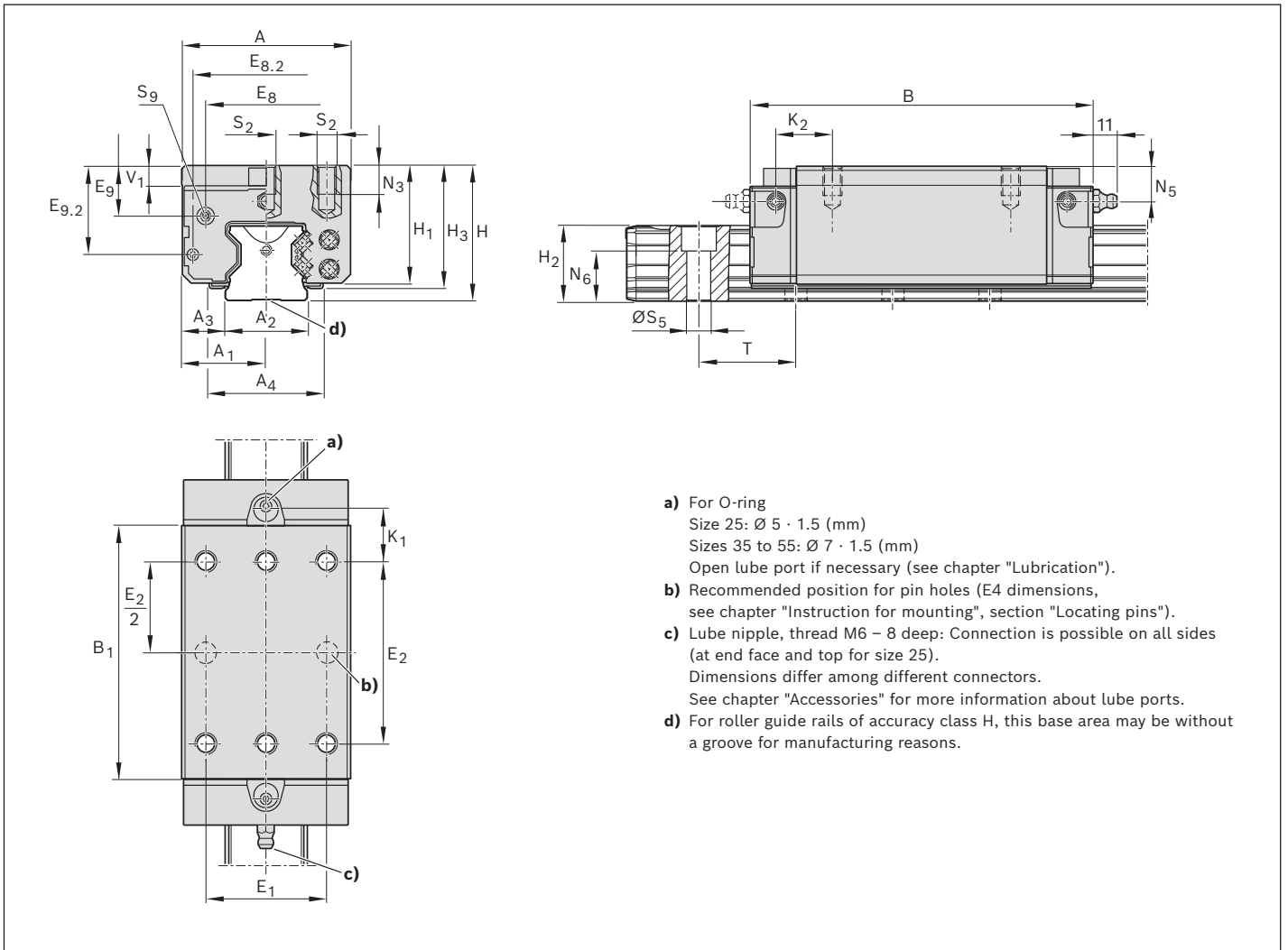
**Dimensions (mm)**

Size	A	A <sub>1</sub>	A <sub>2</sub>	A <sub>3</sub>	A <sub>4</sub> <sup>1)</sup>	B	B <sub>1</sub>	E <sub>1</sub>	E <sub>2</sub>	E <sub>8</sub>	E <sub>8.2</sub>	E <sub>9</sub>	E <sub>9.2</sub>
25	48	24	23	12.5	–	115.00	81.5	35	50	33.4	40.2	12.30	25.40
35	70	35	34	18.0	47.0	142.00	103.6	50	72	50.3	60.5	20.10	36.10
45	86	43	45	20.5	55.6	179.50	134.0	60	80	62.9	72.0	26.70	46.50
55	100	50	53	23.5	63.3	209.65	162.1	75	95	74.2	81.6	28.85	50.75

Size	H	H <sub>1</sub>	H <sub>2</sub> <sup>2)</sup>	H <sub>2</sub> <sup>3)</sup>	H <sub>3</sub> <sup>4)</sup>	K <sub>1</sub>	K <sub>2</sub>	N <sub>3</sub>	N <sub>5</sub>	N <sub>6</sub> <sup>±0.5</sup>	S <sub>2</sub>	S <sub>5</sub>	S <sub>9</sub> <sup>5)</sup>	T <sup>6)</sup>	V <sub>1</sub>
25	40	34	23.60	23.40	–	20.55	–	8	9.5	14.3	M6	7	M3-6.5 deep	30.0	7.5
35	55	48	31.10	30.80	50	22.55	24.40	13	14.0	19.4	M8	9	M3-6.0 deep	40.0	8.0
45	70	61	39.10	38.80	63	33.70	36.60	18	18.0	22.4	M10	14	M4-9.0 deep	52.5	10.0
55	80	68	47.85	47.55	70	41.25	44.40	19	19.0	28.7	M12	16	M5-8.0 deep	60.0	12.0

- 1) Dimension A<sub>4</sub> = Width of the additional longitudinal seal
- 2) Dimension H<sub>2</sub> with cover strip
- 3) Dimension H<sub>2</sub> without cover strip
- 4) Dimension H<sub>3</sub> = Total roller runner block including the additional longitudinal seal
- 5) Thread for connecting parts
- 6) Dimension T = Rail separation of the roller guide rail

# Product description, Roller runner block Resist CR

## General notes on the Roller runner block Resist CR

### Low-corrosion Resist CR coating: matte-silver, hard chrome plated

Roller runner block made of steel with low-corrosion coating Resist CR, matte silver finish, hard chrome plated. For material numbers, please refer to the following pages. For dimensions, load capacities, rigidity and torques, please refer to the corresponding R18 roller runner block.. ... 2X.

⚠ Due to the manufacturing process, some surfaces (e.g. bores, countersinks, inner contours, contact points, etc.) may not be coated.

## Impact on tolerances and preload

### Differing tolerances for "Resist CR" coating

⚠ For roller runner blocks and roller guide rails Resist CR, matte-silver, hard chrome plated, deviating tolerances of the dimensions H and A<sub>3</sub> are to be observed (see "Accuracy classes and their tolerances").

### Higher preload upon combination of hard chrome plated roller runner blocks and hard chrome plated roller guide rails

When hard chrome plated roller runner blocks are combined with preload C2 hard chrome plated roller guide rails, this increases the preload by approx. half a preload class.

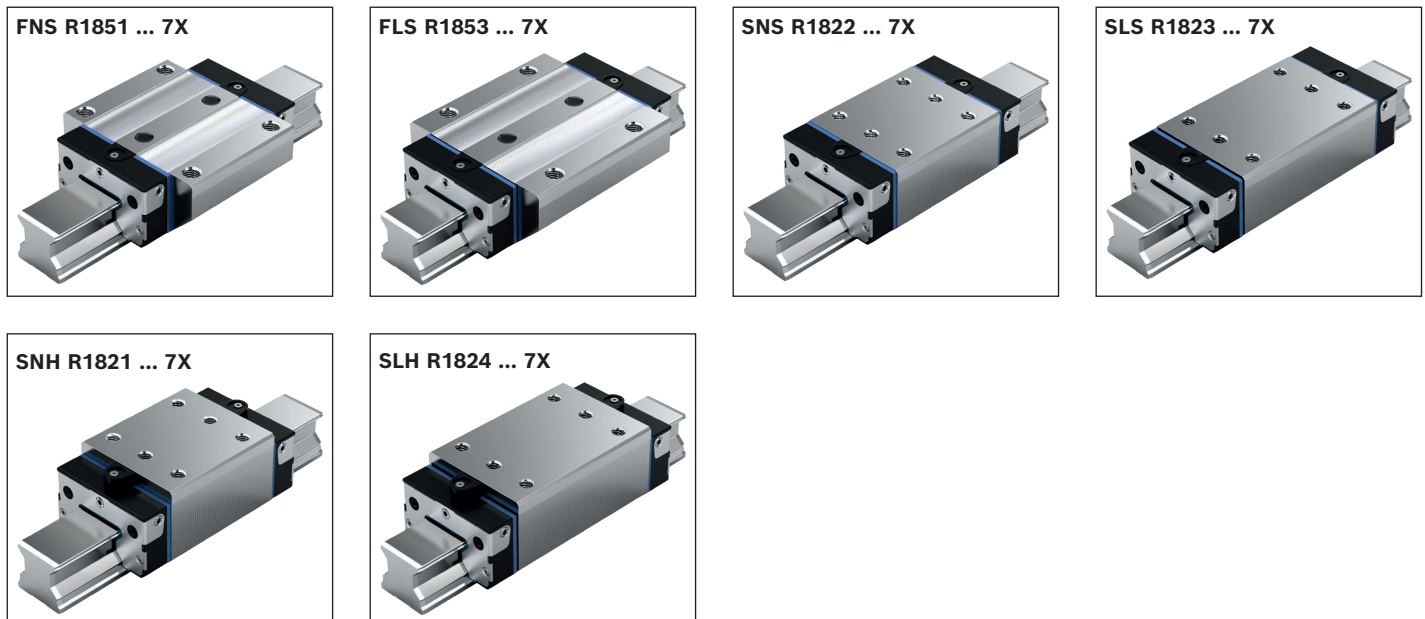

## Identification system of material numbers

Material number	Example:
Rolling element	R 18 51 3 2 3 7X
Format	= Roller = <u>18</u>
	= FNS = <u>51</u> / FLS = 53 / SNS = 22 / SLS = 23 / SNH = 21 / SLH = 24
Size	= 25 / <u>35</u> / 45 / 55 / 65
Preload	= C <u>2</u>
Accuracy class	= H = <u>3</u> / P = 2 / SP = 1
Seal	= DS = <u>7X</u>

**Material numbers, Resist CR, matte-silver, hard chrome plated**

Size	Roller runner block with size	Preload class	Accuracy class <sup>1)</sup>	Seal
		C2	H	DS
<b>R1851 ... 7. FNS – Flanged, normal, standard height</b>				
25	R1851 2	2	3	7X
35	R1851 3	2	3	7X
45	R1851 4	2	3	7X
55	R1851 5	2	3	7X
65	R1851 6	2	3	7X
<b>R1853 ... 7. FLS – Flanged, long, standard height</b>				
25	R1853 2	2	3	7X
35	R1853 3	2	3	7X
45	R1853 4	2	3	7X
55	R1853 5	2	3	7X
65	R1853 6	2	3	7X
<b>R1822 ... 7. SNS – Slimline, normal, standard height</b>				
25	R1822 2	2	3	7X
35	R1822 3	2	3	7X
45	R1822 4	2	3	7X
55	R1822 5	2	3	7X
65	R1822 6	2	3	7X
<b>R1823 ... 7. SLS – Slimline, long, standard height</b>				
25	R1823 2	2	3	7X
35	R1823 3	2	3	7X
45	R1823 4	2	3	7X
55	R1823 5	2	3	7X
65	R1823 6	2	3	7X
<b>R1821 ... 7. SNH – Slimline, normal, high</b>				
25	R1821 2	2	3	7X
35	R1821 3	2	3	7X
45	R1821 4	2	3	7X
55	R1821 5	2	3	7X
<b>R1824 ... 7. SLH – Slimline, long, high</b>				
25	R1824 2	2	3	7X
35	R1824 3	2	3	7X
45	R1824 4	2	3	7X
55	R1824 5	2	3	7X

1) Accuracy classes P and SP on request

**Ordering example**

Options:

- ▶ Roller runner blocks FLS
- ▶ Size 25
- ▶ Preload class C2
- ▶ Accuracy class H
- ▶ Double-lip seal (DS)

Material number:

R1853 223 7X

**Preload classes**

C2 = Average preload

**Seals**

DS = Double-lip seal

# Product description

## Characteristic features

- ▶ Roller guide rails hardened and smoothed in the running track zone
- ▶ Maximum rigidity in all directions of loading
- ▶ Very high torque load capacity

### Roller guide rail SNS with the proven cover strip for covering the fastening bores

- ▶ One cover for all bore holes saves time and costs
- ▶ Made of stainless spring steel as per DIN EN 10088
- ▶ Easy and safe during mounting
- ▶ Clip on and secure



## Overview of formats and models

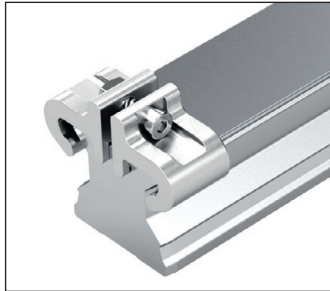

**SNS with cover strip and strip clamps**

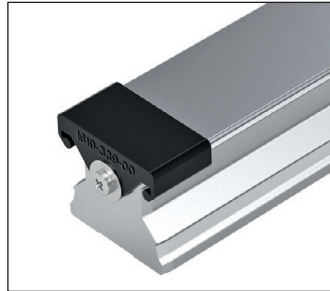

**SNS with cover strip and protective caps**

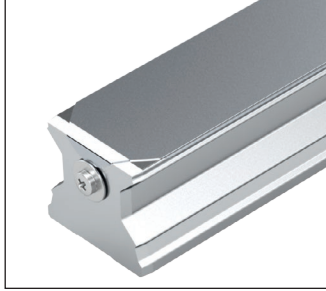

**SNS with cover strip and screw/washer**



**SNS for cover strip**

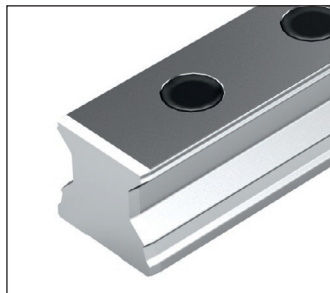

**SNS with plastic caps**

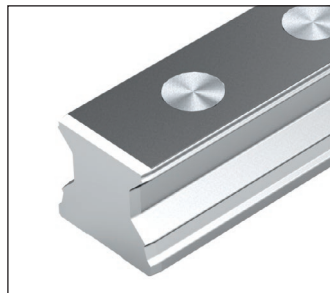

**SNS with steel caps**

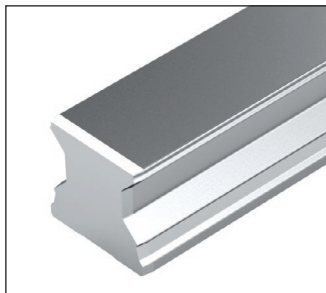

**SNS for mounting from below**

### Definition of the format of roller guide rails

Criterion	Designation	Code (example)		
		S	N	S
<b>Width</b>	Slimline ( <b>S</b> )	S		
<b>Length</b>	Normal ( <b>N</b> )		N	
<b>Height</b>	Standard height ( <b>S</b> )			S
	Without groove ( <b>O</b> )			O

# Ordering roller guide rails in the recommended rail lengths

The recommended rail length prescribes the length grid for the price design of the profile rail. This length grid also applies to the customer-specific desired length.

Recommended rail lengths have preferred delivery times.

**From the desired rail length to the recommended length**

$$L = \left( \frac{L_W}{T} \right) \cdot T - 4$$

Round up quotient  $L_W/T$  to the nearest whole number!

**Calculation example**

$$L = \frac{1660 \text{ mm}}{40 \text{ mm}} \cdot 40 \text{ mm} - 4 \text{ mm}$$

$$L = 42 \cdot 40 \text{ mm} - 4 \text{ mm}$$

$$L = 1676 \text{ mm}$$

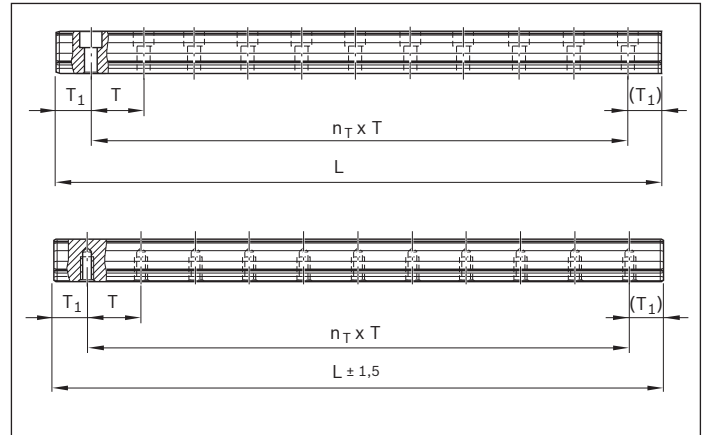

Basis: Number of holes

$$L = n_B \cdot T - 4$$

- L = Recommended rail length (mm)
- $L_W$  = Desired rail length (mm)
- T = Pitch (mm)
- $T_{1S}$  = Preferred dimension (mm)
- $n_B$  = Number of holes
- $n_T$  = Number of spaces

Basis: Number of spaces

$$L = n_T \cdot T + 2 \cdot T_{1S}$$

If preferred dimension  $T_{1S}$  is not used, it is possible to choose between:

- ▶ Select end spacing  $T_1$  between  $T_{1S}$  and  $T_{1 \min}$ .
- ▶ As an alternative, it is possible to choose end spacings  $T_1$  to  $T_{1 \max}$ .
- ▶ Observe minimum distances  $T_{1 \min}$  and  $T_{1 \max}$ !

## Identification system of material numbers

<b>Material number</b>		Example: <b>R 18 05 3 3 1 62, 5036</b>
<b>Rolling element</b>	= Roller = <b>18</b>	
<b>Version</b>	= <u>Standard rail for bolting from above</u> = <b>05</b> / Rail with steel caps = 06 / Rail for mounting from below = 07	
<b>Size</b>	= 25 / <b>35</b> / 45 / 55 / 65	
<b>Model</b>	= <u>with cover strip and strip clamps</u> = <b>3</b> (smooth surface = B) / with cover strip and protective caps = 6 (smooth surface = D) / for cover strip = 2 (smooth surface = A) / for plastic/steel caps = 5 (smooth floor surface = C) / without cover (rail for mounting from below) = 0	
<b>Accuracy class</b>	= H=3 / P=2 / <u>SP</u> = <b>1</b> / GP=8 / UP=9	
<b>Number of sections</b>	= One-piece=31, or 61, / multiple parts= 32, or <b>62</b> , (number of components =2), ...	
<b>Rail length (mm)</b>	= <b>5036</b> mm	

## SNS/SNO with cover strip and strip clamps

### R1805 .3. .. / R1805 .B. ..

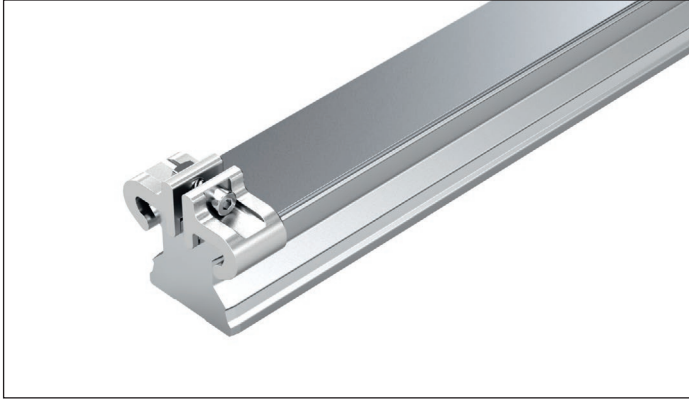

**For bolting from above, with cover strip made of corrosion-resistant spring steel per EN 10088 and strip clamps made of aluminum (without end-face thread bore hole)**

#### Notes

- ▶ Secure the cover strip!
- ▶ Strip clamps included in scope of delivery.
- ▶ Observe the instruction for mounting!
- ▶ Please request the "Mounting instructions for Roller Rail Systems" and "Mounting instructions for cover strip".
- ▶ Composite roller guide rail also available.

**Roller guide rails R1805 .B. .. with smooth base area for mounting surfaces from cast mineral parts**  
**In size 35-65 and available in accuracy class H, P, SP, GP, UP upon request.**

#### Material numbers

Size	Roller guide rail with size	Accuracy class					Number of sections		Hole spacing T (mm)	Recommended rail lengths	
		H	P	SP	GP	UP	One-piece	Composite		$L = n_B \cdot T - 4 \text{ mm}$	Maximum number of bores $n_B$
25	R1805 23	3	2	1	8	9	31, ....	3., ...	30.0		133
35	R1805 33	3	2	1	8	9	61, ....	6., ...	40.0		100
45	R1805 43	3	2	1	8	9	61, ....	6., ...	52.5		76
55	R1805 53	3	2	1	8	9	61, ....	6., ...	60.0		66
65	R1805 63	3	2	1	8	9	61, ....	6., ...	75.0		53

#### Ordering example 1 (to $L_{max}$ )

Options:

- ▶ Roller guide rail SNS
- ▶ Size 35
- ▶ Accuracy class P
- ▶ One-piece
- ▶ Rail length

$L = 1676 \text{ mm}$

Material number:

R1805 332 61, 1676 mm

#### Ordering example 2 (above $L_{max}$ )

Options:

- ▶ Roller guide rail SNS
- ▶ Size 35
- ▶ Accuracy class P
- ▶ Multi-part (2 parts)
- ▶ Rail length

$L = 5036 \text{ mm}$

Material number:

R1805 332 62, 5036 mm

#### Ordering example 3 (up to $L_{max}$ with smooth surface)

Options:

- ▶ Roller guide rail SNO
- ▶ Size 35
- ▶ Accuracy class P
- ▶ One-piece
- ▶ Rail length

$L = 1676 \text{ mm}$

Material number:

R1805 3B2 61, 1676 mm

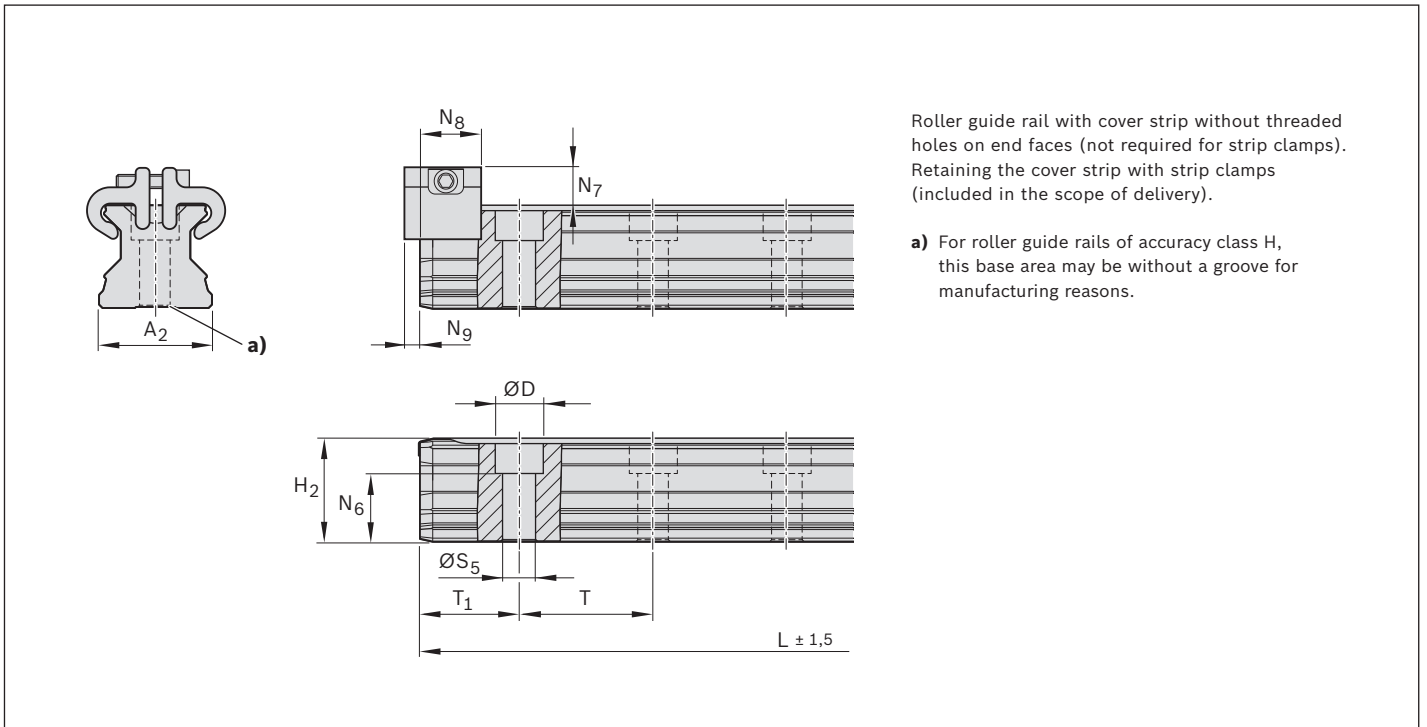

Roller guide rail with cover strip without threaded holes on end faces (not required for strip clamps). Retaining the cover strip with strip clamps (included in the scope of delivery).

a) For roller guide rails of accuracy class H, this base area may be without a groove for manufacturing reasons.

### Dimensions (mm)

Size	A <sub>2</sub>	D	H <sub>2</sub> <sup>1)</sup>	L <sub>max</sub> <sup>2)</sup>	N <sub>6</sub> <sup>±0.5</sup>	N <sub>7</sub> <sup>3)</sup>	N <sub>8</sub>	N <sub>9</sub>	S <sub>5</sub>	T <sub>1 min</sub>	T <sub>1 max</sub>	T <sub>1 S</sub> <sup>4)</sup>	T	Mass (kg/m)
25	23	11	23.60	3986	14.3	8.2	13	2.0	7	13	20.0	13.00	30.0	3.1
35	34	15	31.10	3996	19.4	11.7	16	2.2	9	16	28.0	18.00	40.0	6.3
45	45	20	39.10	3986	22.4	12.5	18	2.2	14	18	36.5	24.25	52.5	10.3
55	53	24	47.85	3956	28.7	14.0	17	3.2	16	20	42.0	28.00	60.0	13.1
65	63	26	58.15	3971	36.5	15.0	17	3.2	18	21	55.0	35.50	75.0	17.4

- 1) Dimension H<sub>2</sub> with cover strip  
 Size 25 with cover strip 0.2 mm  
 Size 35 with cover strip 0.3 mm
- 2) Size 35: also deliverable as one piece up to a length of 5996 mm  
 Size 45: also deliverable as one piece up to a length of 5981 mm  
 Size 55: also deliverable as one piece up to a length of 5936 mm  
 Size 65: also available as one piece up to a length of 5921 mm
- 3) Dimension N<sub>7</sub> with cover strip
- 4) Preferred dimension T<sub>1 S</sub> with tolerances ± 0.75

# SNS/SNO with cover strip and protective caps

## R1805 .6. .. / R1805 .D. ..



**For bolting from above, with cover strip made of corrosion-resistant spring steel per EN 10088 and screw-down plastic protective caps (with end-face thread bore hole)**

### Notes

- ▶ As an alternative, the cover strip can be secured with screws and washers.
- ▶ Protective caps with screws and washers are included in the scope of delivery.
- ▶ Observe the instruction for mounting!
- ▶ Please request the "Mounting instructions for Roller Rail Systems" and "Mounting instructions for cover strip".
- ▶ Composite roller guide rail also available.

**Roller guide rails R1805 .D. .. with smooth base area for mounting surfaces from cast mineral parts**  
**In size 35-65 and available in accuracy class H, P, SP, GP, UP upon request.**

### Material numbers

Size	Roller guide rail with size	Accuracy class					Number of sections		Hole spacing T (mm)	Recommended rail lengths $L = n_B \cdot T - 4 \text{ mm}$ Maximum number of bores $n_B$
		H	P	SP	GP	UP	One-piece	Composite		
25	R1805 26	3	2	1	8	9	31, ....	3., ...	30.0	133
35	R1805 36	3	2	1	8	9	61, ....	6., ...	40.0	100
45	R1805 46	3	2	1	8	9	61, ....	6., ...	52.5	76
55	R1805 56	3	2	1	8	9	61, ....	6., ...	60.0	66
65	R1805 66	3	2	1	8	9	61, ....	6., ...	75.0	53

#### Ordering example 1 (to $L_{\max}$ )

Options:

- ▶ Roller guide rail SNS
- ▶ Size 35
- ▶ Accuracy class P
- ▶ One-piece
- ▶ Rail length  
L = 1676 mm

Material number:

R1805 362 61, 1676 mm

#### Ordering example 2 (above $L_{\max}$ )

Options:

- ▶ Roller guide rail SNS
- ▶ Size 35
- ▶ Accuracy class P
- ▶ Multi-part (2 parts)
- ▶ Rail length  
L = 5036 mm

Material number:

R1805 362 62, 5036 mm

#### Ordering example 3 (up to $L_{\max}$ with smooth surface)

Options:

- ▶ Roller guide rail SNO
- ▶ Size 35
- ▶ Accuracy class P
- ▶ One-piece
- ▶ Rail length  
L = 1676 mm

Material number:

R1805 3D2 61, 1676 mm

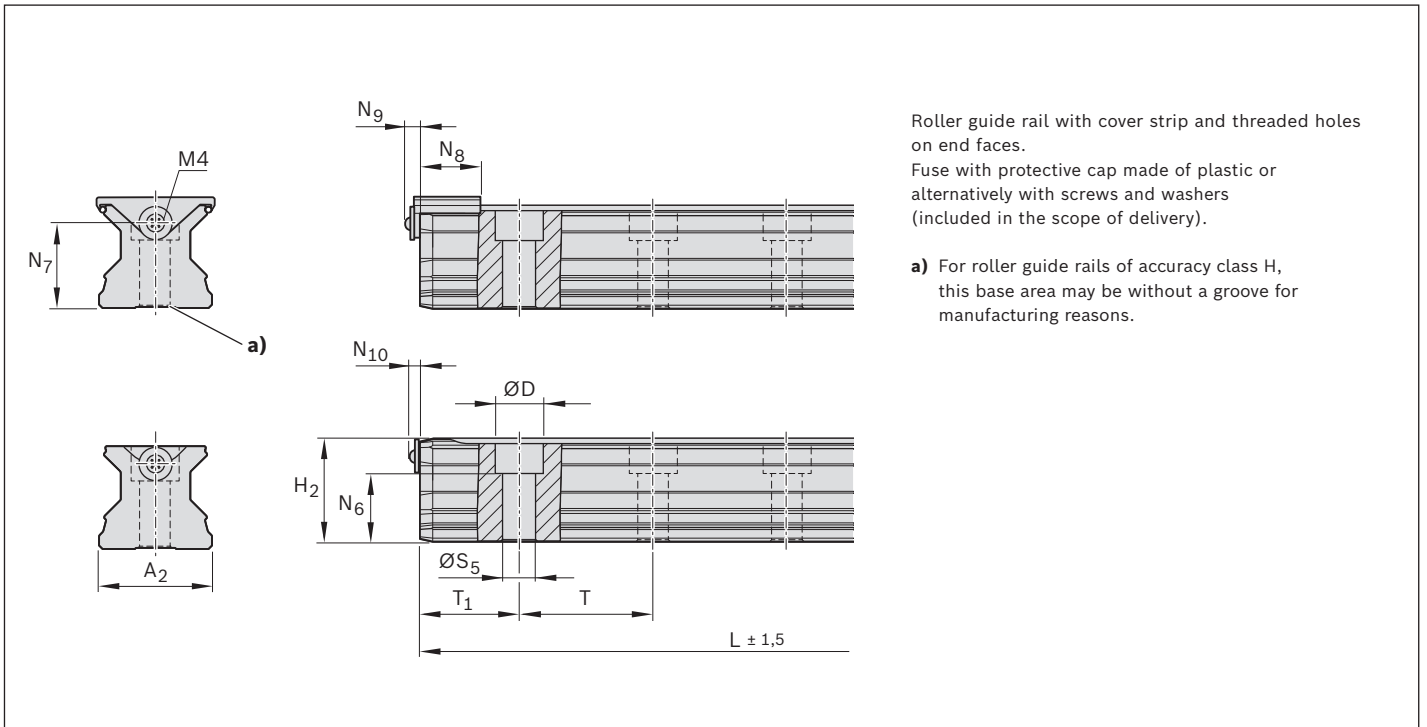
**Dimensions (mm)**

Size	A <sub>2</sub>	D	H <sub>2</sub> <sup>1)</sup>	L <sub>max</sub> <sup>2)</sup>	N <sub>6</sub> <sup>±0.5</sup>	N <sub>7</sub>	N <sub>8</sub>	N <sub>9</sub>	N <sub>10</sub>	S <sub>5</sub>	T <sub>1min</sub>	T <sub>1max</sub>	T <sub>1S</sub> <sup>3)4)</sup>	T	Mass (kg/m)
25	23	11	23.60	3986	14.3	15	15.2	6.5	4.10	7	13	20.0	13.00	30.0	3.1
35	34	15	31.10	3996	19.4	22	18	7.0	4.10	9	16	28.0	18.00	40.0	6.3
45	45	20	39.10	3986	22.4	30	20	7.0	4.10	14	18	36.5	24.25	52.5	10.3
55	53	24	47.85	3956	28.7	30	20	7.0	4.35	16	20	42.0	28.00	60.0	13.1
65	63	26	58.15	3971	36.5	40	20	7.0	4.35	18	21	55.0	35.50	75.0	17.4

- 1) Dimension H<sub>2</sub> with cover strip  
 Size 25 with cover strip 0.2 mm  
 Size 35 with cover strip 0.3 mm
- 2) Size 35: also deliverable as one piece up to a length of 5996 mm  
 Size 45: also deliverable as one piece up to a length of 5981 mm  
 Size 55: also deliverable as one piece up to a length of 5936 mm  
 Size 65: also available as one piece up to a length of 5921 mm
- 3) Preferred dimension T<sub>1S</sub> with tolerances ± 0.75
- 4) When undercutting T<sub>1min</sub>, no end-face thread possible. Secure the cover strip! See instruction for mounting.

## SNS/SNO for cover strip

### R1805 .2. 3./R1805 .A. 3.



**For mounting from above, for cover strip  
(not included in scope of delivery)**

#### Notes

- ▶ Secure the cover strip!
- ▶ Order cover strip and strip clamps or protective caps separately. See chapter "Accessories" for material numbers and dimensions.
- ▶ Observe the instruction for mounting!
- ▶ Please request the "Mounting instructions for Roller Rail Systems" and "Mounting instructions for cover strip".
- ▶ Composite roller guide rail also available.

**Roller guide rails R1805 .A. 3. .. with smooth base area  
for mounting surfaces from cast mineral parts  
In size 35-65 and available in accuracy class H, P, SP, GP,  
UP upon request.**

#### Material numbers

Size	Roller guide rail with size	Accuracy class					Number of sections		Hole spacing T (mm)	Recommended rail lengths $L = n_B \cdot T - 4 \text{ mm}$ Maximum number of bores $n_B$	
		H	P	SP	GP	UP	One-piece	Composite			
25	R1805 22	3	2	1	8	9	31, ....	3., ...	30.0		133
35	R1805 32	3	2	1	8	9	31, ....	3., ...	40.0		100
45	R1805 42	3	2	1	8	9	31, ....	3., ...	52.5		76
55	R1805 52	3	2	1	8	9	31, ....	3., ...	60.0		66
65	R1805 62	3	2	1	8	9	31, ....	3., ...	75.0		53

#### Ordering example 1 (to $L_{\max}$ )

Options:

- ▶ Roller guide rail SNS
- ▶ Size 35
- ▶ Accuracy class P
- ▶ One-piece
- ▶ Rail length  
L = 1676 mm

Material number:

R1805 322 31, 1676 mm

#### Ordering example 2 (above $L_{\max}$ )

Options:

- ▶ Roller guide rail SNS
- ▶ Size 35
- ▶ Accuracy class P
- ▶ Multi-part (2 parts)
- ▶ Rail length  
L = 5036 mm

Material number:

R1805 322 32, 5036 mm

#### Ordering example 3 (up to $L_{\max}$ with smooth surface)

Options:

- ▶ Roller guide rail SNO
- ▶ Size 35
- ▶ Accuracy class P
- ▶ One-piece
- ▶ Rail length  
L = 1676 mm

Material number:

R1805 3A2 31, 1676 mm

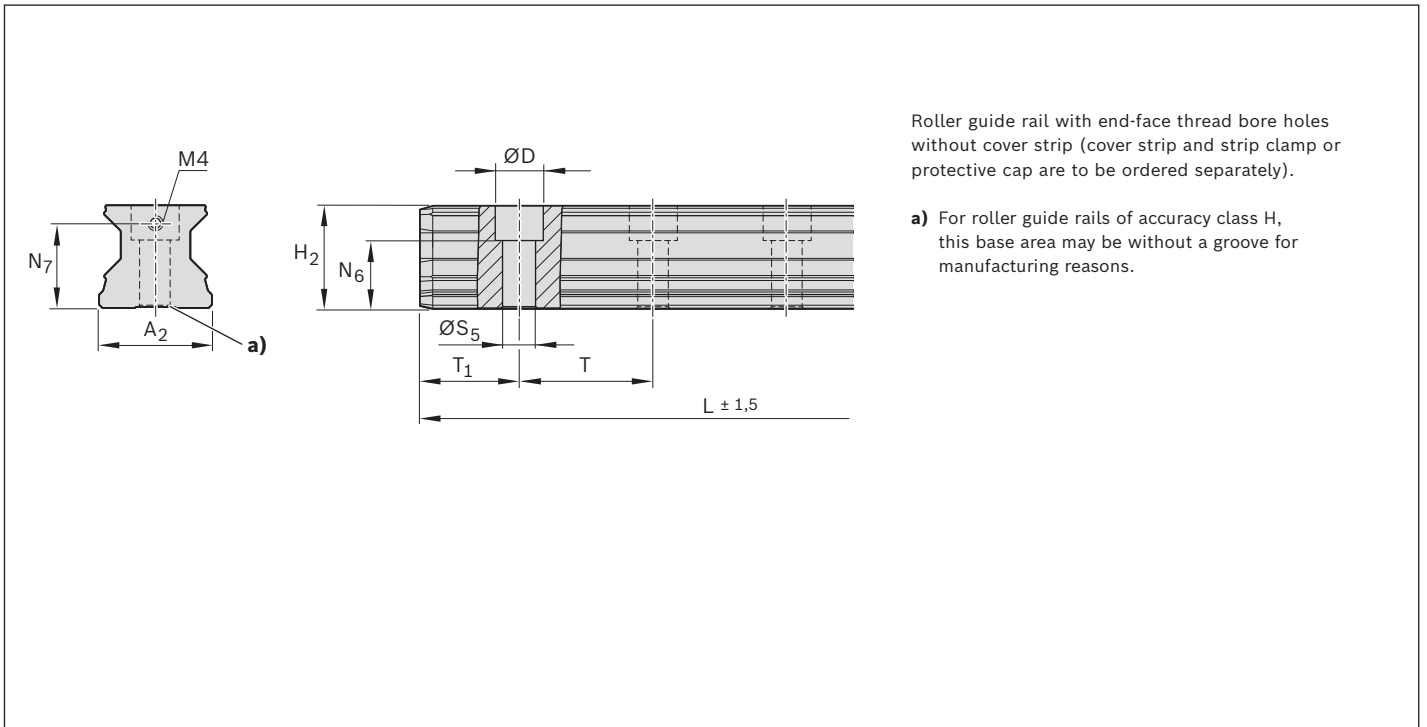
**Dimensions (mm)**

Size	A <sub>2</sub>	D	H <sub>2</sub>	L <sub>max</sub> <sup>1)</sup>	N <sub>6</sub> <sup>±0.5</sup>	N <sub>7</sub>	S <sub>5</sub>	T <sub>1 min</sub>	T <sub>1 max</sub>	T <sub>1 s</sub> <sup>2) 3)</sup>	T	Mass (kg/m)
25	23	11	23.40	3986	14.3	15	7	13	20.0	13.00	30.0	3.1
35	34	15	30.80	3996	19.4	22	9	16	28.0	18.00	40.0	6.3
45	45	20	38.80	3986	22.4	30	14	18	36.5	24.25	52.5	10.3
55	53	24	47.55	3956	28.7	30	16	20	42.0	28.00	60.0	13.1
65	63	26	57.85	3971	36.5	40	18	21	55.0	35.50	75.0	17.4

- 1) Size 35: also deliverable as one piece up to a length of 5996 mm  
 Size 45: also deliverable as one piece up to a length of 5981 mm  
 Size 55: also deliverable as one piece up to a length of 5936 mm  
 Size 65: also available as one piece up to a length of 5921 mm
- 2) Preferred dimension T<sub>1s</sub> with tolerances ± 0.75
- 3) When undercutting T<sub>1 min</sub>, no end-face thread possible. Secure the cover strip! See instruction for mounting.

## SNS/SNO with plastic caps

### R1805 .5. 3./R1805 .C. 3.



#### For bolting from above with plastic caps

#### Notes

- ▶ Plastic caps included in scope of supply.
- ▶ Observe the instruction for mounting!
- ▶ Please ask for the "Mounting Instructions for Roller Rail Systems".
- ▶ Composite roller guide rail also available.

**Roller guide rails R1805 .C. 3. .. with smooth base area for mounting surfaces from cast mineral parts**  
**In size 35-65 and available in accuracy class H, P, SP, GP, UP upon request.**

#### Material numbers

Size	Roller guide rail with size	Accuracy class					Number of sections		Hole spacing T (mm)	Recommended rail lengths	
		H	P	SP	GP	UP	One-piece	Composite		$L = n_B \cdot T - 4 \text{ mm}$	Maximum number of bores $n_B$
25	R1805 25	3	2	1	8	9	31, ....	3., ...	30.0		133
35	R1805 35	3	2	1	8	9	31, ....	3., ...	40.0		100
45	R1805 45	3	2	1	8	9	31, ....	3., ...	52.5		76
55	R1805 55	3	2	1	8	9	31, ....	3., ...	60.0		66
65	R1805 65	3	2	1	8	9	31, ....	3., ...	75.0		53

#### Ordering example 1 (to $L_{max}$ )

Options:

- ▶ Roller guide rail SNS
- ▶ Size 35
- ▶ Accuracy class P
- ▶ One-piece
- ▶ Rail length  
L = 1676 mm

Material number:

R1805 352 31, 1676 mm

#### Ordering example 2 (above $L_{max}$ )

Options:

- ▶ Roller guide rail SNS
- ▶ Size 35
- ▶ Accuracy class P
- ▶ Multi-part (2 parts)
- ▶ Rail length  
L = 5036 mm

Material number:

R1805 352 **32**, 5036 mm

#### Ordering example 3 (up to $L_{max}$ with smooth surface)

Options:

- ▶ Roller guide rail SNO
- ▶ Size 35
- ▶ Accuracy class P
- ▶ One-piece
- ▶ Rail length  
L = 1676 mm

Material number:

R1805 **3C2** 31, 1676 mm

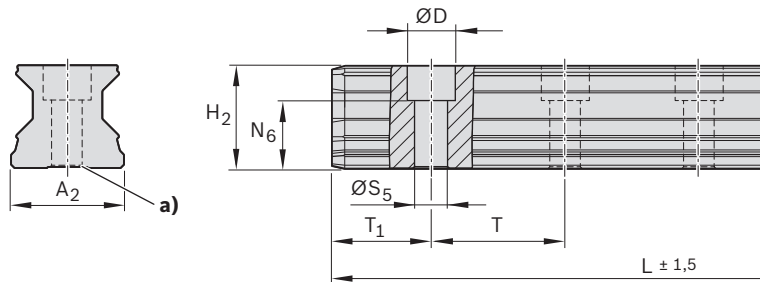

Plastic caps come with the roller guide rails and are also available as accessories.  
For mounting plastic mounting hole plugs, see "Mounting instructions for Roller Rail Systems."

a) For roller guide rails of accuracy class H, this base area may be without a groove for manufacturing reasons.

#### Dimensions (mm)

Size	$A_2$	D	$H_2$	$L_{\max}^{1)}$	$N_6^{\pm 0,5}$	$S_5$	$T_{1 \min}$	$T_{1 \max}$	$T_{1S}^{2)}$	T	Mass (kg/m)
25	23	11	23.40	3986	14.3	7	10	20.0	13.00	30.0	3.1
35	34	15	30.80	3996	19.4	9	12	28.0	18.00	40.0	6.3
45	45	20	38.80	3986	22.4	14	16	36.5	24.25	52.5	10.3
55	53	24	47.55	3956	28.7	16	18	42.0	28.00	60.0	13.1
65	63	26	57.85	3971	36.5	18	20	55.0	35.50	75.0	17.4

- 1) Size 35: also deliverable as one piece up to a length of 5996 mm  
Size 45: also deliverable as one piece up to a length of 5981 mm  
Size 55: also deliverable as one piece up to a length of 5936 mm  
Size 65 and 65/100: also available as one piece up to a length of 5921 mm
- 2) Preferred dimension  $T_{1S}$  with tolerances  $\pm 0.75$

## SNS/SNO with steel caps R1806 .5. 3./R1806 .C. 3.

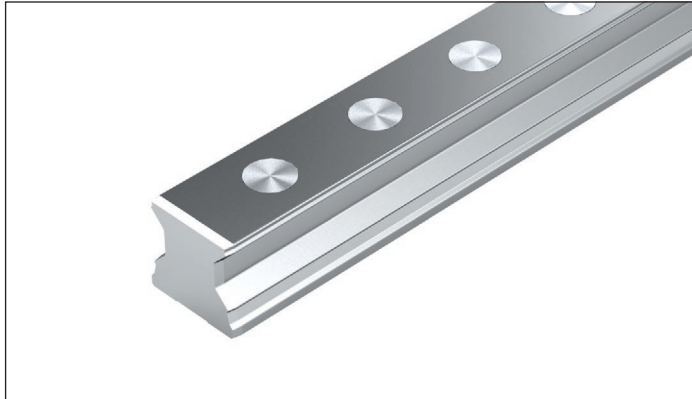

**For bolting from above, for steel caps (not included in the scope of delivery)**

### Notes

- ▶ Steel caps are not included in the scope of delivery of the roller guide rails. Order separately (see "Accessories for roller guide rails")
- ▶ The mounting tool is to be ordered separately (see "Accessories for roller guide rails")!
- ▶ Observe the instruction for mounting!
- ▶ Please ask for the "Mounting Instructions for Roller Rail Systems".
- ▶ Composite roller guide rail also available.

**Roller guide rails R1806 .C. 3. with smooth base area for mounting surfaces from cast mineral parts**  
Available in size 35-65 and in accuracy class H, P, SP, GP.

### Material numbers

Size	Roller guide rail with size	Accuracy class				Number of sections		Hole spacing T (mm)	Recommended rail lengths $L = n_B \cdot T - 4 \text{ mm}$ Maximum number of bores $n_B$	
		H	P	SP	GP	One-piece	Composite			
25	R1806 25	3	2	1	8	31, ...	3., ...	30.0		133
35	R1806 35	3	2	1	8	31, ...	3., ...	40.0		100
45	R1806 45	3	2	1	8	31, ...	3., ...	52.5		76
55	R1806 55	3	2	1	8	31, ...	3., ...	60.0		66
65	R1806 65	3	2	1	8	31, ...	3., ...	75.0		53

#### Ordering example 1 (to $L_{\max}$ )

Options:

- ▶ Roller guide rail SNS
- ▶ Size 35
- ▶ Accuracy class P
- ▶ One-piece
- ▶ Rail length  
L = 1676 mm

Material number:

R1806 352 31, 1676 mm

#### Ordering example 2 (above $L_{\max}$ )

Options:

- ▶ Roller guide rail SNS
- ▶ Size 35
- ▶ Accuracy class P
- ▶ Multi-part (2 parts)
- ▶ Rail length  
L = 5036 mm

Material number:

R1806 352 32, 5036 mm

#### Ordering example 3 (up to $L_{\max}$ with smooth surface)

Options:

- ▶ Roller guide rail SNO
- ▶ Size 35
- ▶ Accuracy class P
- ▶ One-piece
- ▶ Rail length  
L = 1676 mm

Material number:

R1806 3C2 31, 1676 mm

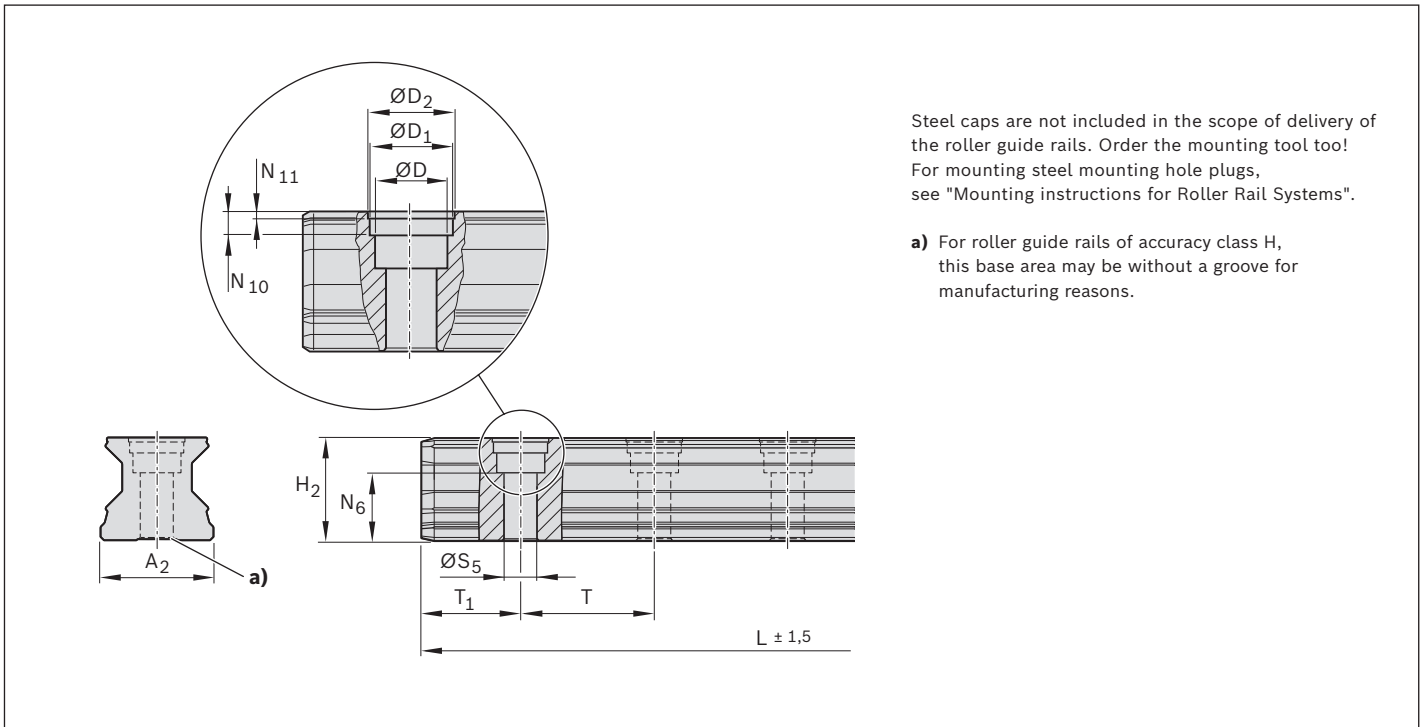

Steel caps are not included in the scope of delivery of the roller guide rails. Order the mounting tool too! For mounting steel mounting hole plugs, see "Mounting instructions for Roller Rail Systems".

- a) For roller guide rails of accuracy class H, this base area may be without a groove for manufacturing reasons.

### Dimensions (mm)

Size	A <sub>2</sub>	D	D <sub>1</sub>	D <sub>2</sub>	H <sub>2</sub>	L <sub>max</sub> <sup>1)</sup>	N <sub>6</sub> <sup>±0.5</sup>	N <sub>10</sub>	N <sub>11</sub>	S <sub>5</sub>	T <sub>1 min</sub>	T <sub>1 max</sub>	T <sub>1 S</sub> <sup>2)</sup>	T	Mass (kg/m)
<b>25</b>	23	11	12.55	13	23.40	3986	14.3	3.7	0.90	7	13	20.0	13.00	30.0	3.1
<b>35</b>	34	15	17.55	18	30.80	3996	19.4	3.6	0.90	9	16	28.0	18.00	40.0	6.3
<b>45</b>	45	20	22.55	23	38.80	3986	22.4	8.0	1.45	14	18	36.5	24.25	52.5	10.3
<b>55</b>	53	24	27.55	28	47.55	3956	28.7	8.0	1.45	16	20	42.0	28.00	60.0	13.1
<b>65</b>	63	26	29.55	30	57.85	3971	36.5	8.0	1.45	18	21	55.0	35.50	75.0	17.4

- 1) Size 35: also deliverable as one piece up to a length of 5996 mm  
 Size 45: also deliverable as one piece up to a length of 5981 mm  
 Size 55: also deliverable as one piece up to a length of 5936 mm  
 Size 65: also available as one piece up to a length of 5921 mm
- 2) Preferred dimension T<sub>1S</sub> with tolerances ± 0.75

## SNS for bolting from below

### R1807 .0. 3.

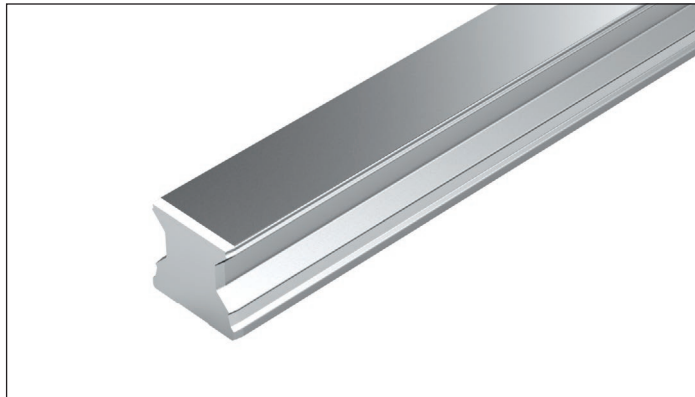

#### For bolting from below

#### Notes

- ▶ Observe the instruction for mounting!
- ▶ Please ask for the "Mounting Instructions for Roller Rail Systems".
- ▶ Composite roller guide rail also available.

#### Material numbers

Size	Roller guide rail with size	Accuracy class					Number of sections		Hole spacing T (mm)	Recommended rail lengths	
		H	P	SP	GP	UP	One-piece	Composite		$L = n_B \cdot T - 4 \text{ mm}$	Maximum number of bores $n_B$
25	R1807 20	3	2	1	8	9	31, ....	3., ...	30.0		133
35	R1807 30	3	2	1	8	9	31, ....	3., ...	40.0		100
45	R1807 40	3	2	1	8	9	31, ....	3., ...	52.5		76
55	R1807 50	3	2	1	8	9	31, ....	3., ...	60.0		66
65	R1807 60	3	2	1	8	9	31, ....	3., ...	75.0		53

#### Ordering example 1

(to  $L_{max}$ )

Options:

- ▶ Roller guide rail SNS
- ▶ Size 35
- ▶ Accuracy class P
- ▶ One-piece
- ▶ Rail length  
L = 1676 mm

Material number:

R1807 302 31, 1676 mm

#### Ordering example 2

(above  $L_{max}$ )

Options:

- ▶ Roller guide rail SNS
- ▶ Size 35
- ▶ Accuracy class P
- ▶ Multi-part (2 parts)
- ▶ Rail length  
L = 5036 mm

Material number:

R1807 302 32, 5036 mm

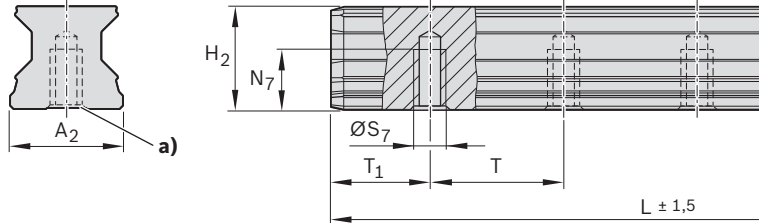

a) For roller guide rails of accuracy class H, this base area may be without a groove for manufacturing reasons.

### Dimensions (mm)

Size	$A_2$	$H_2$	$L_{max}$	$N_7$	$S_7$	$T_{1 min}$	$T_{1 max}$	$T_{1 S}^{1)}$	$T$	Mass (kg/m)
25	23	23.40	3986	12	M6	10	20.0	13.00	30.0	3.1
35	34	30.80	3996	15	M8	12	28.0	18.00	40.0	6.3
45	45	38.80	3986	19	M12	16	36.5	24.25	52.5	10.3
55	53	47.55	3956	22	M14	18	42.0	28.00	60.0	13.1
65	63	57.85	3971	25	M16	20	55.0	35.50	75.0	17.4

1) Preferred dimension  $T_{1 S}$  with tolerances  $\pm 0.75$

# Product description roller guide rails Resist CR, matte-silver hard chrome plated

## General notes on roller guide rails Resist CR

### Low-corrosion Resist CR coating: matte-silver, hard chrome plated

Steel roller guide rails with the low-corrosion coating Resist CR, matte-silver, hard chrome plated.

For material numbers, please refer to the following page. Recommended rail lengths up to  $L_{\max.} < 4$  m, for dimensions and weights please refer to the corresponding standard steel roller guide rails.

⚠ Due to the manufacturing process, some surfaces (e.g. bores, countersinks, inner contours, contact points, etc.) may not be coated.

## Impact on tolerances and preload

### Differing tolerances for "Resist CR" coating

⚠ For roller runner blocks and roller guide rails Resist CR, matte-silver, hard chrome plated, deviating tolerances of the dimensions H and  $A_3$  are to be observed (see "Accuracy classes and their tolerances").

### Higher preload upon combination of hard chrome plated roller runner blocks and hard chrome plated roller guide rails

When hard chrome plated roller runner blocks are combined with preload C2 hard chrome plated roller guide rails, this increases the preload by approx. half a preload class.

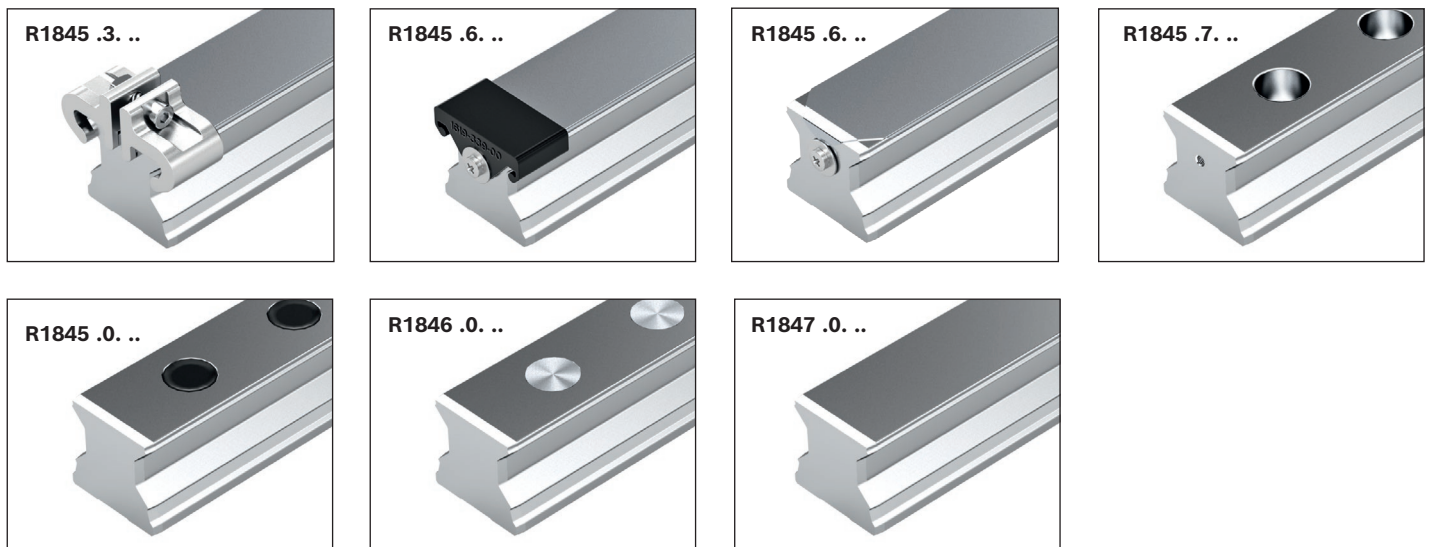

## Identification system of material numbers

Material number		Example: R 18 45 3 3 3 71, 1676
Rolling element	= Roller = 18	
Version	= Standard rail for mounting from above = 45	
Size	= 35	
Model	= with cover strip and strip clamp = 3	
Accuracy class	= H = 3 / P = 2 / SP = 1	
Number of sections	= One-piece = 41 or 71	
Rail length (mm)	= 1676 mm	

**Material numbers, Resist CR, matte-silver, hard chrome plated**

Size	Roller guide rail with size	Accuracy class <sup>1)</sup> H	Number of sections	
			One-piece	Composite
<b>R1845 .3. .. SNS with cover strip and strip clamps</b>				
25	R1845 23	3	41, ....	4., ...
35	R1845 33	3	71, ....	7., ...
45	R1845 43	3	71, ....	7., ...
55	R1845 53	3	71, ....	7., ...
65	R1845 63	3	71, ....	7., ...
<b>R1845 .6. .. SNS with cover strip and protective caps</b>				
25	R1845 26	3	41, ....	4., ...
35	R1845 36	3	71, ....	7., ...
45	R1845 46	3	71, ....	7., ...
55	R1845 56	3	71, ....	7., ...
65	R1845 66	3	71, ....	7., ...
<b>R1845 .7. .. SNS for cover strip</b>				
25	R1845 27	3	41, ....	4., ...
35	R1845 37	3	41, ....	4., ...
45	R1845 47	3	41, ....	4., ...
55	R1845 57	3	41, ....	4., ...
65	R1845 67	3	41, ....	4., ...
<b>R1845 .0. .. SNS with plastic caps</b>				
25	R1845 20	3	41, ....	4., ...
35	R1845 30	3	41, ....	4., ...
45	R1845 40	3	41, ....	4., ...
55	R1845 50	3	41, ....	4., ...
65	R1845 60	3	41, ....	4., ...
<b>R1846 .0. .. SNS with steel caps</b>				
25	R1846 20	3	41, ....	4., ...
35	R1846 30	3	41, ....	4., ...
45	R1846 40	3	41, ....	4., ...
55	R1846 50	3	41, ....	4., ...
65	R1846 60	3	41, ....	4., ...
<b>R1847 .0. .. SNS for mounting from below</b>				
25	R1847 20	3	41, ....	4., ...
35	R1847 30	3	41, ....	4., ...
45	R1847 40	3	41, ....	4., ...
55	R1847 50	3	41, ....	4., ...
65	R1847 60	3	41, ....	4., ...

1) Accuracy classes P and SP on request

**Ordering example (above  $L_{max}$ )**

Options:

- ▶ Rail for mounting from below
- ▶ Size 45
- ▶ Accuracy class H
- ▶ Multi-part (2 parts)
- ▶ Rail length  
L = 5036 mm

Material number: R1847 403 42, 5036 mm

# Product description roller guide rails Resist CR II, black hard chrome plated

## General notes on the roller guide rails Resist CR II

### Low-corrosion coating Resist CR II black hard chrome plated

Steel roller guide rails with the low-corrosion coating Resist CR II, black, hard chrome plated.

For material numbers, please refer to the following page. Recommended rail lengths up to  $L_{max} < 4$  m, for dimensions and weights please refer to the corresponding standard steel roller guide rails.

⚠ Due to the manufacturing process, some surfaces (e.g. bores, countersinks, inner contours, contact points, etc.) may not be coated.

### Impact on tolerances and preload

#### Differing tolerances for "Resist CR II" coating

⚠ For roller runner blocks and roller guide rails Resist CR II, black, hard chrome plated, deviating tolerances of the dimensions H and  $A_3$  are to be observed (see "Accuracy classes and their tolerances").

#### Higher preload upon combination of hard chrome plated roller runner blocks and hard chrome plated roller guide rails

When hard chrome plated roller runner blocks are combined with preload C2 hard chrome plated roller guide rails, this increases the preload by approx. half a preload class.

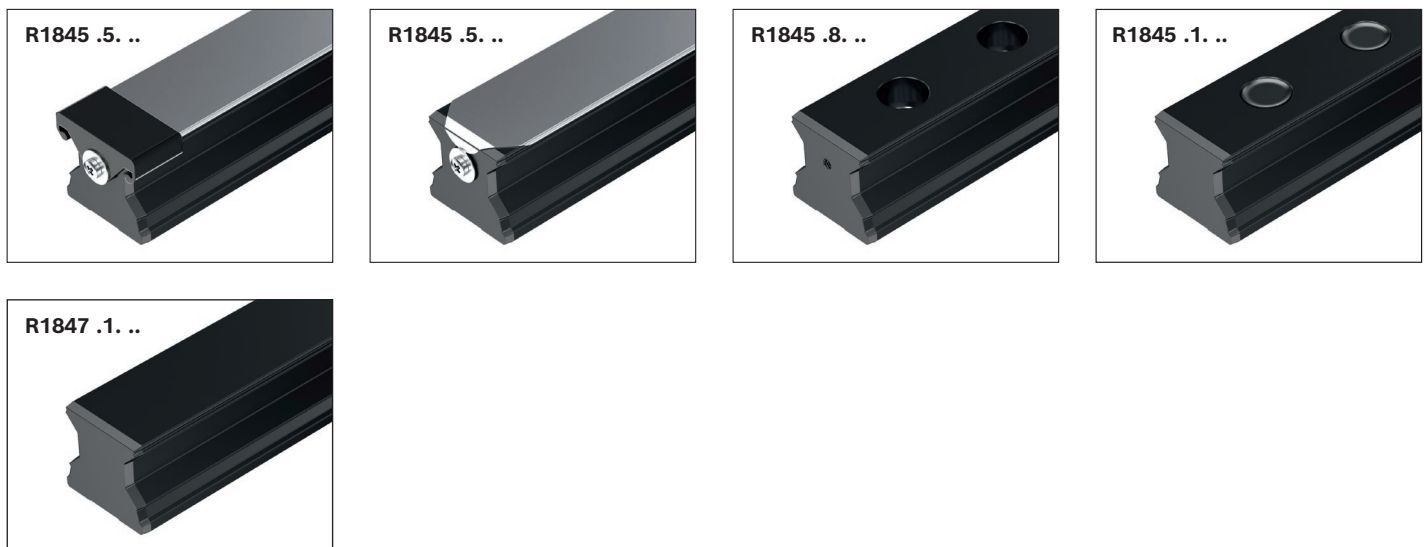

### Identification system of material numbers

Material number		Example: R 18 45 3 5 3 71, 1676
Rolling element	= Roller = 18	
Version	= Standard rail for mounting from above = 45	
Size	= 35	
Model	= with cover strip and protective caps = 5	
Accuracy class	= H = 3 / P = 2 / SP = 1	
Number of sections	= One-piece = 41 or 71	
Rail length (mm)	= 1676 mm	

**Material numbers Resist CR II, black, hard chrome plated**

Size	Roller guide rail with size	Accuracy class <sup>1)</sup> H	Number of sections	
			One-piece	Composite
<b>R1845 .5. .. SNS with cover strip<sup>2)</sup> and protective caps</b>				
25	R1845 25	3	41, ....	4., ...
35	R1845 35	3	71, ....	7., ...
45	R1845 45	3	71, ....	7., ...
55	R1845 55	3	71, ....	7., ...
65	R1845 65	3	71, ....	7., ...
<b>R1845 .8. .. SNS for cover strip</b>				
25	R1845 28	3	41, ....	4., ...
35	R1845 38	3	41, ....	4., ...
45	R1845 48	3	41, ....	4., ...
55	R1845 58	3	41, ....	4., ...
65	R1845 68	3	41, ....	4., ...
<b>R1845 .1. .. SNS with plastic caps</b>				
25	R1845 21	3	41, ....	4., ...
35	R1845 31	3	41, ....	4., ...
45	R1845 41	3	41, ....	4., ...
55	R1845 51	3	41, ....	4., ...
65	R1845 61	3	41, ....	4., ...
<b>R1847 .1. .. SNS for mounting from below</b>				
25	R1847 21	3	41, ....	4., ...
35	R1847 31	3	41, ....	4., ...
45	R1847 41	3	41, ....	4., ...
55	R1847 51	3	41, ....	4., ...
65	R1847 61	3	41, ....	4., ...

1) Accuracy classes P and SP on request

2) Cover strip not coated

**Ordering example (above L<sub>max</sub>)**

Options:

- ▶ Rail for mounting from below
- ▶ Size 45
- ▶ Accuracy class H
- ▶ Multi-part (2 parts)
- ▶ Rail length  
L = 5036 mm

Material number: R1847 413 42, 5036 mm

# Roller guide rails with temperature control, product description

## Characteristic features

### Faster starting, more precise movement, simple conversion

What used to only be possible with a lot of effort and special solutions is now available for the first time as standard: Rexroth has integrated temperature control into the guide rail. Wherever fast travel cycles and the highest precision are required, guide rails can now be started without any run-in time. Always at the perfect temperature and thermally stable. And with less waste. Ideal for retrofitting: Simply replace the rail and connect to the existing cooling circuit. You can turn your standard machines into precision machines in no time at all!

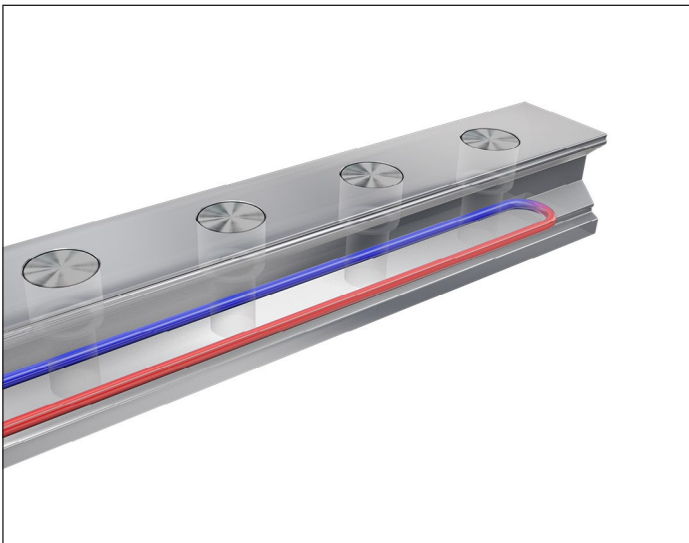
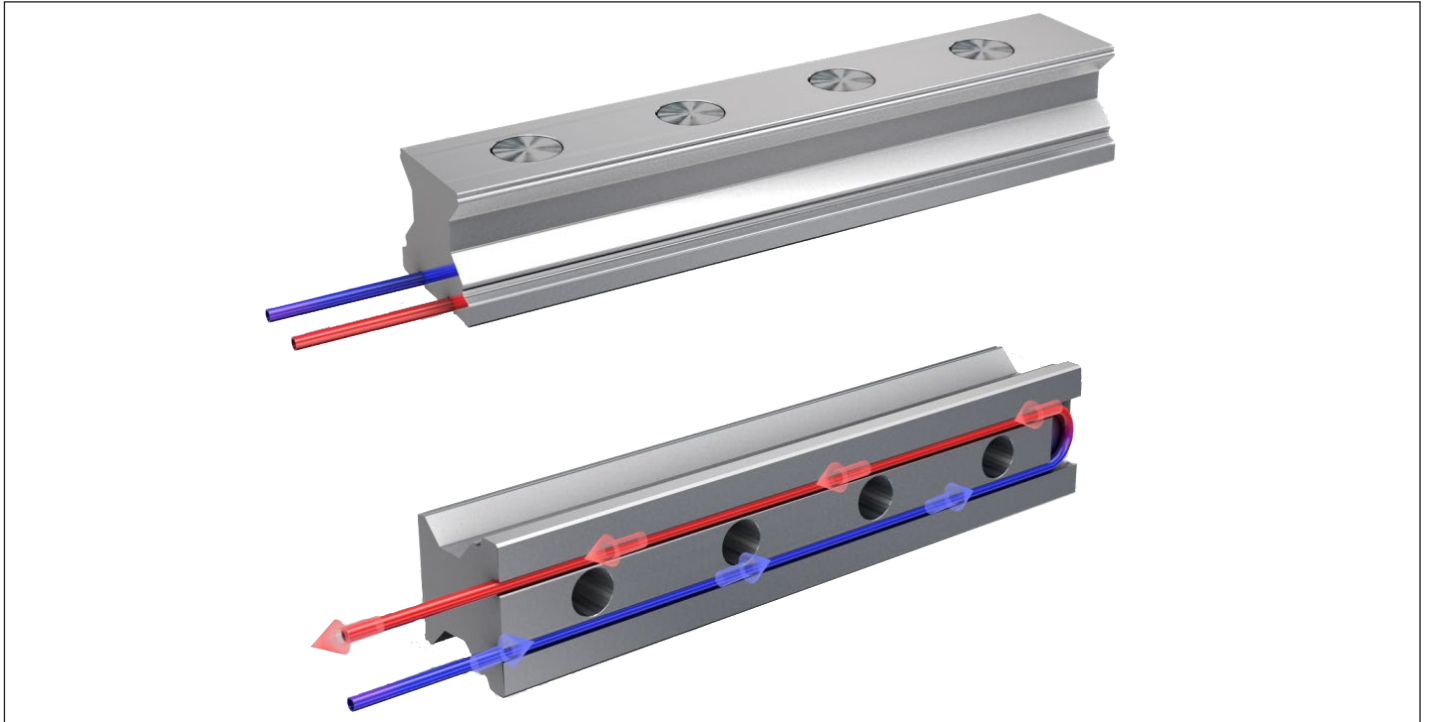

### Extremely precise movement, flexible adjustment

Since the new guide rails by Rexroth remove the heat from where it is created or supplies it to where it is needed you have complete freedom. No matter where your machine is positioned or what material the machine bed is made from, the linear guides work with high precision and are thermally stable. No run-in time, with good parts right from the first part onwards. This ensures the greatest availability and increases part accuracy by up to 75%. Even with existing machines: rails can be easily connected to existing cooling circuits with ready to connect piping. Finished.

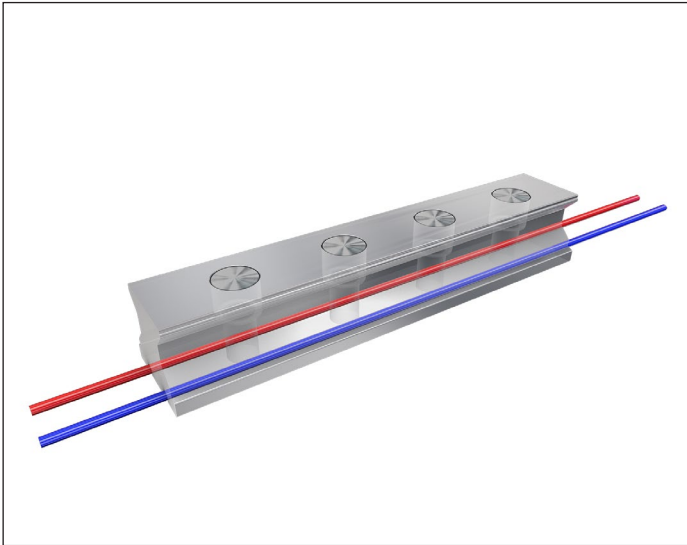

### Further highlights

- ▶ High precision: Up to 75% higher part accuracy, regardless of environment
- ▶ Always available: No run-in to the operating temperature
- ▶ Flexible: Can be adjusted to changes as required
- ▶ Can be retrofitted: compatible with existing systems
- ▶ Simple: Uses existing cooling circuits

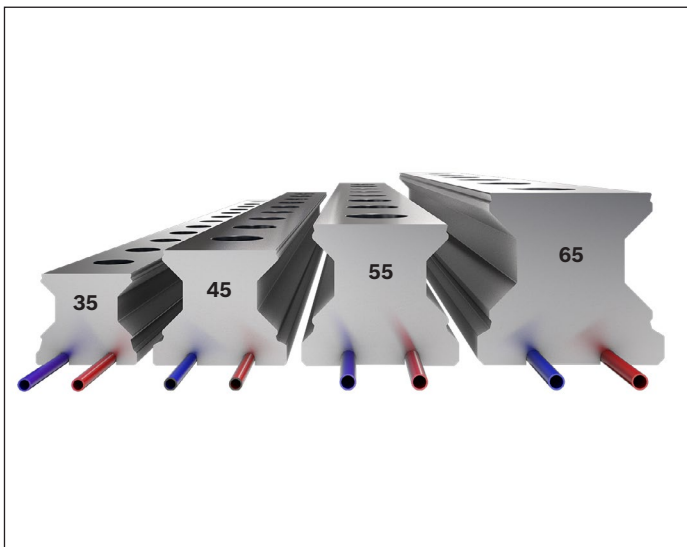

### Technical features

- ▶ Roller guide sizes: 35/45/55/65
- ▶ Formats: R1805
- ▶ Rail covers: Cover strip, caps
- ▶ Series with/without groove
- ▶ Accuracy classes: P/GP/SP
- ▶ Rail lengths: up to max. 4000 mm
- ▶ Redirecting temperature control: To the rails or universal
- ▶ Patented

## Rethinking machine tools



# Product description

## Characteristic features

- ▶ Heavy-duty roller runner blocks for heavy machine construction with extremely high load-bearing capacity
- ▶ Maximum rigidity in all directions of loading
- ▶ Improved rigidity under lift-off and side loading conditions due to additional fixing at three bores at the center of the roller runner block
- ▶ High torque load capacity
- ▶ Limitless interchangeability and any number of combination options thanks to uniform roller guide rails in different versions across all roller runner block variants
- ▶ Attachments on the roller runner block can be mounted from above and below

## Further highlights

- ▶ Lube nipples possible on all sides for easy maintenance
- ▶ Low lubrication quantities thanks to innovative channel design
- ▶ Roller runner blocks made from anti-friction bearing steel with hardened and ground tracks (roller guide rails also hardened and smoothed in the track zone)
- ▶ Smooth, quiet running thanks to optimally designed return and guideways of the rollers
- ▶ Minimal variation in elastic deflection thanks to optimized entry-zone geometry and high number of rollers
- ▶ Aluminum or plastic end caps
- ▶ Integrated front seals are included as standard for improved sealing of all running tracks and to protect the plastic parts

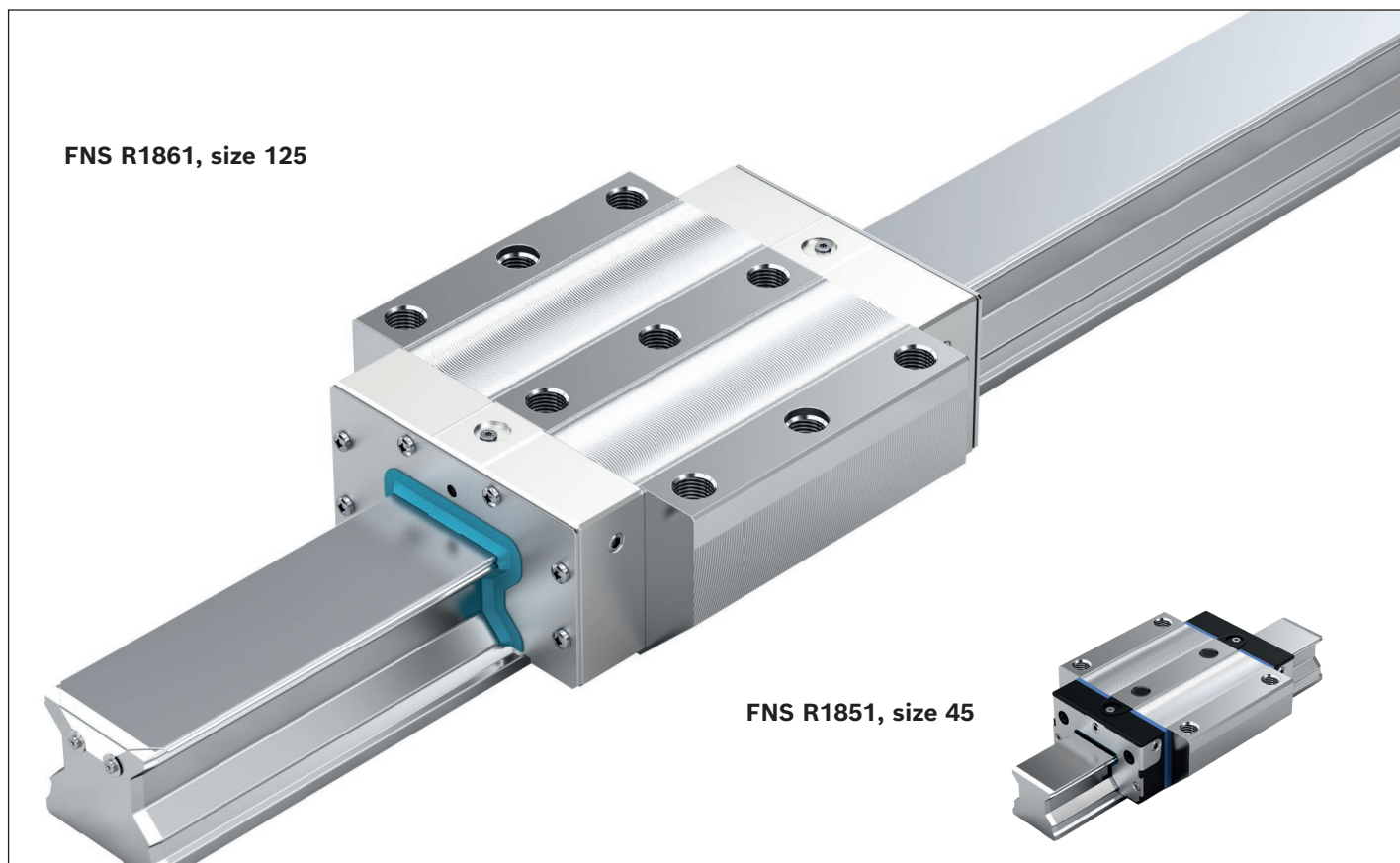

## Optional versions

- ▶ Low-corrosion heavy-duty roller runner blocks and roller guide rails Resist CR, matte-silver finish, hard chrome plated, available in accuracy class H (preloads C2 and C3)

**FNS R1861, size 100**

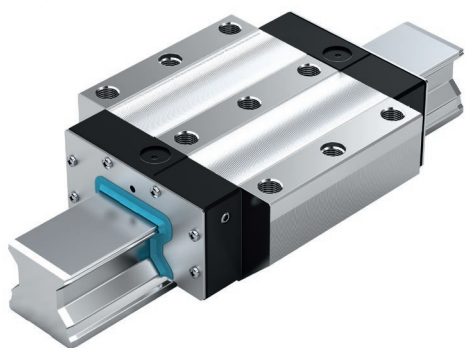

**FLS R1863, size 125**

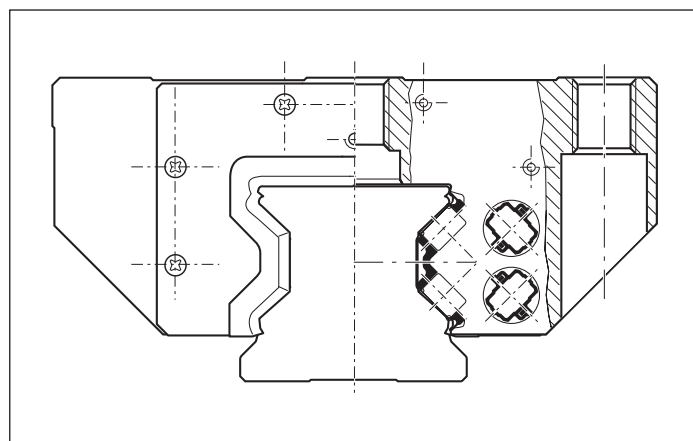
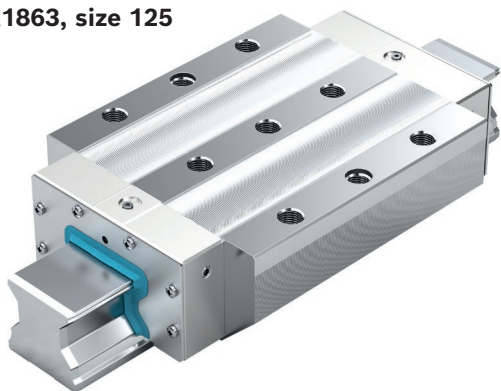

### Heavy-duty roller runner blocks for heavy machine construction

- ▶ End caps made of aluminum (size 125) or plastic (size 100)
- ▶ Standard front seals

### Optimum structural design of the roller guide rail

- ▶ Quiet running thanks to optimally designed roller return and guideway

## Heavy-duty roller runner blocks FXS - Flange, extra long, standard height, made of steel R1854 ... 1.

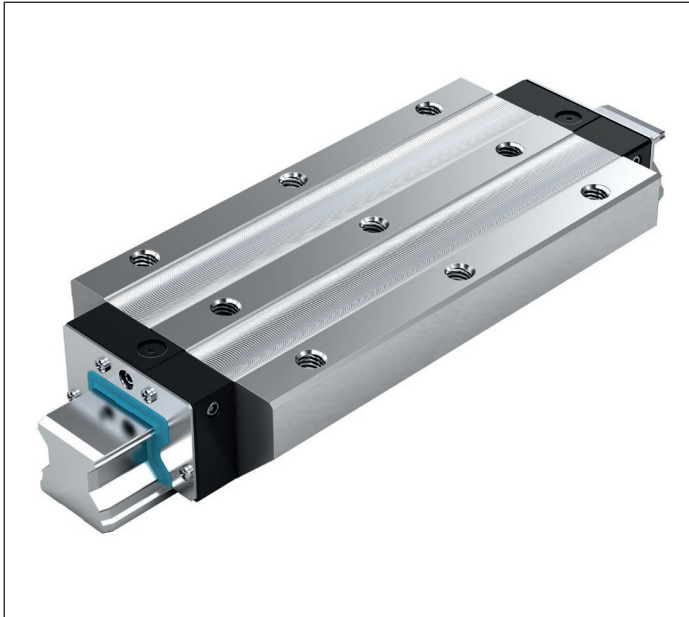

### Dynamic characteristics

Travel speed:  $v_{\max} = 3 \text{ m/s}$

Acceleration:  $a_{\max} = 150 \text{ m/s}^2$



### Recommended combination based on preload and accuracy class

- ▶ For preload C2: H and P (preferably)
- ▶ For preload C3: P and SP

### Material numbers

Size	Roller runner block with size	Preload class		Accuracy class				Seal
		C2	C3	H	P	SP	UP	SS
65	R1854 6	2		3	2	1	9	10
			3		2	1	9	10

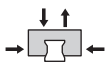
### Technical data

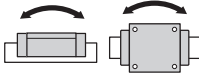
Size	Mass (kg)	Load capacities <sup>1)</sup> (N)		Torsional moment load capacity <sup>1)</sup> (Nm)		Longitudinal moment load capacity <sup>1)</sup> (Nm)				
	<b>m</b>		<b>C</b>	<b>C<sub>0</sub></b>		<b>M<sub>t</sub></b>	<b>M<sub>t0</sub></b>		<b>M<sub>L</sub></b>	<b>M<sub>L0</sub></b>
65	20.30	366800	792800	13030	28170	15760	34060			

1) Determination of the dynamic load capacities and load moments is based on a travel of 100,000 m according to DIN ISO 14728-1. Often only 50,000 m are actually stipulated. For comparison: Multiply values C, M<sub>t</sub> and M<sub>L</sub> from the table by 1.23.

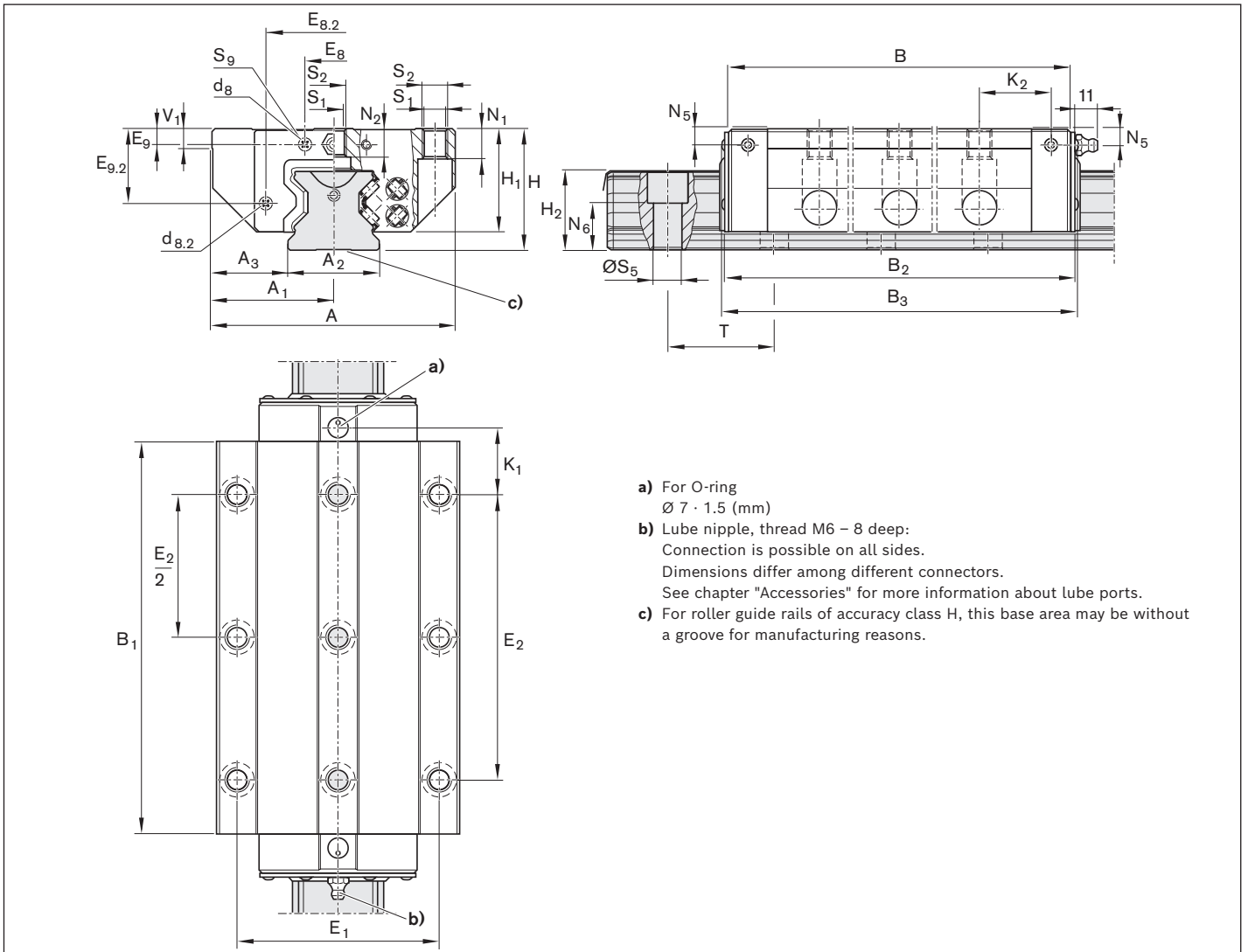

**Dimensions (mm)**

Size	A	A <sub>1</sub>	A <sub>2</sub>	A <sub>3</sub>	B	B <sub>1</sub>	B <sub>2</sub>	B <sub>3</sub>	d <sub>8</sub>	d <sub>8.2</sub>	E <sub>1</sub>	E <sub>2</sub>	E <sub>8</sub>	E <sub>8.2</sub>	E <sub>9</sub>	E <sub>9.2</sub>
65	170	85	63	53.5	335	275	339.5	345	8	8	142	200	35.0	106.00	9.30	55.00

Size	H	H <sub>1</sub>	H <sub>2</sub> <sup>1)</sup>	H <sub>2</sub> <sup>2)</sup>	K <sub>1</sub>	K <sub>2</sub>	N <sub>1</sub>	N <sub>2</sub>	N <sub>5</sub>	N <sub>6</sub> <sup>±0.5</sup>	S <sub>1</sub>	S <sub>2</sub>	S <sub>5</sub>	S <sub>9</sub> <sup>3)</sup>	T <sup>4)</sup>	V <sub>1</sub>
65	90	76	58.15	57.85	49.5	52.5	23	21.5	9.3	36.5	14.5	M16	18	M4-7 deep	75.0	15.0

- 1) Dimension H<sub>2</sub> with cover strip
- 2) Dimension H<sub>2</sub> without cover strip
- 3) Thread for connecting parts
- 4) Dimension T = Rail separation of the roller guide rail

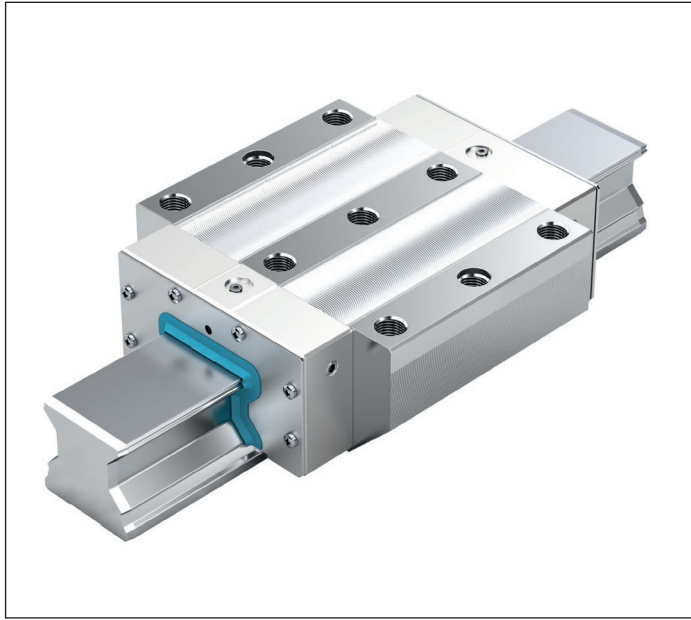
# Heavy-duty roller runner blocks FNS - flanged, normal, standard height, made of steel R1861 ... 1. / Resist CR R1861 ... 6.



### Dynamic characteristics

Travel speed:  $v_{\max} = 2 \text{ m/s}$

Acceleration:  $a_{\max} = 150 \text{ m/s}^2$

### Recommended combination based on preload and accuracy class

- ▶ For preload C2: H and P (preferably)
- ▶ For preload C3: P and SP

### Note

For Roller runner blocks Resist CR, matte-silver, hard chrome plated, deviating tolerances of the dimensions H and  $A_3$  (see "Accuracy classes and their tolerances"). When hard chrome plated roller runner blocks are combined with hard chrome plated roller guide rails, this increases the preload by approx. half a preload class. For short stroke ( $< 2 \cdot B_1$ ) additional lubrication nipples are to be used: Size 125:  $B_4$  and  $N_7$ . All lube ports with thread M8x1 (for size 125 in metal).

### Material numbers of heavy-duty roller runner blocks made of steel

Size	Roller runner block with size	Preload class		Accuracy class			Seal SS
		C2	C3	H	P	SP	
100	R1861 2	2		3	2	1	10
			3	3	2	1	10
125	R1861 3	2		3	2		10
			3	3	2		10

### Material numbers, heavy-duty roller runner blocks Resist CR, matte-silver, hard chrome plated

Size	Roller runner block with size	Preload class		Accuracy class	Seal SS
		C2	C3	H	
100	R1861 2	2	3	3	60
125	R1861 3	2	3	3	60

### Technical data

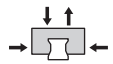
Size	Mass (kg)	Load capacities <sup>1)</sup> (N)		Torsional moment load capacity <sup>1)</sup> (Nm)		Longitudinal moment load capacity <sup>1)</sup> (Nm)	
			$C_0$	$M_t$	$M_{t0}$	$M_L$	$M_{L0}$
	m	C	$C_0$	$M_t$	$M_{t0}$	$M_L$	$M_{L0}$
100	32.0	461000	811700	25720	45290	13550	23850
125	62.1	757200	1324000	54520	95330	29660	51860

1) Determination of the dynamic load capacities and load moments is based on a travel of 100,000 m according to DIN ISO 14728-1. Often only 50,000 m are actually stipulated. For comparison: Multiply values C,  $M_t$  and  $M_L$  from the table by 1.23.

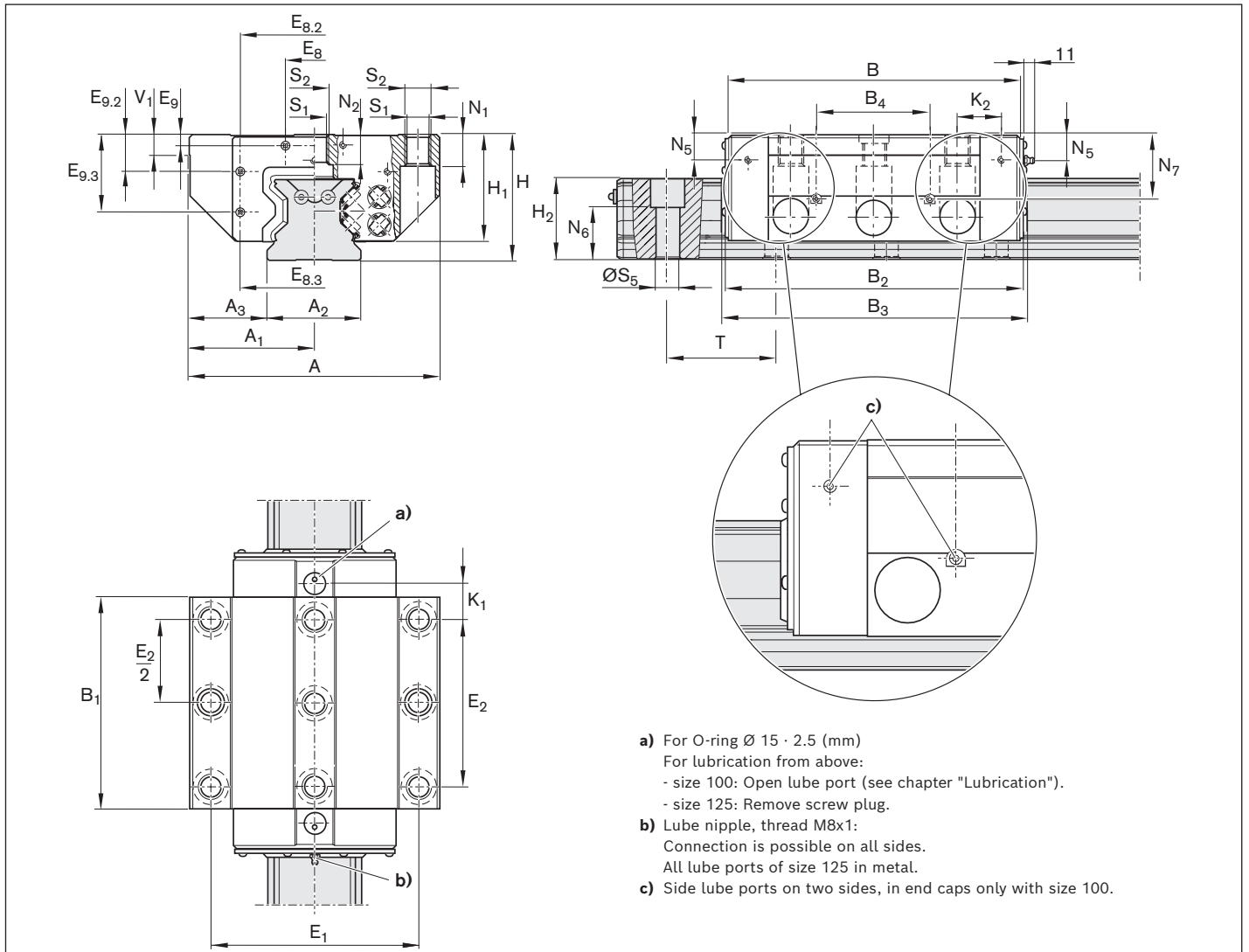
**Dimensions (mm)**

Size	A	A <sub>1</sub>	A <sub>2</sub>	A <sub>3</sub>	B	B <sub>1</sub>	B <sub>2</sub>	B <sub>3</sub>	B <sub>4</sub>	E <sub>1</sub>	E <sub>2</sub>	E <sub>8</sub>	E <sub>8.2</sub>	E <sub>8.3</sub>	E <sub>9</sub>	E <sub>9.2</sub>	E <sub>9.3</sub>
100	250	125	100	75.0	296.5	204	301.5	309.5	–	200	150	64	130	162.6	9	29.4	70
125	320	160	125	97.5	371	255	377	386.5	130	270	205	80	205	205.0	12	40.0	92

Size	H	H <sub>1</sub>	H <sub>2</sub> <sup>1)</sup>	K <sub>1</sub>	K <sub>2</sub>	N <sub>1</sub>	N <sub>2</sub>	N <sub>5</sub>	N <sub>6</sub> <sup>20.5</sup>	N <sub>7</sub>	S <sub>1</sub>	S <sub>2</sub>	S <sub>5</sub>	T	V <sub>1</sub>
100	120	105.0	87.3	44.0	49.9	30	22	17.5	55.0	–	17.5	M20	25	105	20
125	160	135.5	115.3	50.0	50.0	45	29	29.0	74.5	92	25.0	M27	33	120	25

1) Dimension H<sub>2</sub> with cover strip

2) Dimension T = Rail separation of the roller guide rail

**⚠** Due to the manufacturing process, some surfaces (e.g. bores, countersinks, inner contours, contact points, etc.) may not be coated.

# Heavy-duty roller runner blocks FLS - flanged, long, standard height, made of steel R1863 ... 1. / Resist CR R1863 ... 6.

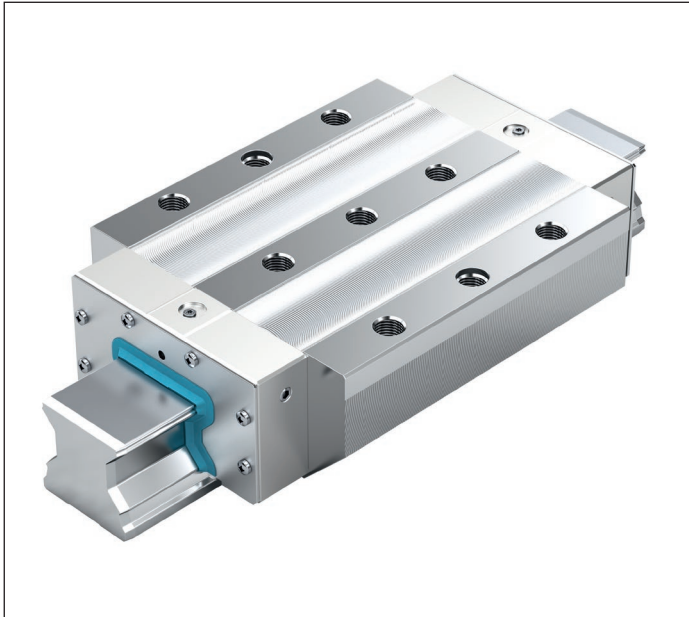

**Dynamic characteristics**

Travel speed:  $v_{max} = 2 \text{ m/s}$

Acceleration:  $a_{max} = 150 \text{ m/s}^2$

**Recommended combination based on preload and accuracy class**

- ▶ For preload C2: H and P (preferably)
- ▶ For preload C3: P and SP

**Note**

For Roller runner blocks Resist CR, matte-silver, hard chrome plated, deviating tolerances of the dimensions H and  $A_3$  (see "Accuracy classes and their tolerances"). When hard chrome plated roller runner blocks are combined with hard chrome plated roller guide rails, this increases the preload by approx. half a preload class. For short stroke ( $< 2 \cdot B_1$ ) additional lubrication nipples are to be used: Size 125:  $B_4$  and  $N_7$   
All lube ports with thread M8x1 (for size 125 in metal).







**Material numbers of heavy-duty roller runner blocks made of steel**

Size	Roller runner block with size	Preload class		Accuracy class			Seal
		C2	C3	H	P	SP	SS
100	R1863 2	2		3	2	1	10
			3	3	2	1	10
125	R1863 3	2		3	2		10
			3	3	2		10

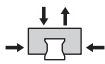
**Material numbers, heavy-duty roller runner blocks Resist CR, matte-silver, hard chrome plated**

Size	Roller runner block with size	Preload class		Accuracy class	Seal
		C2	C3	H	SS
100	R1863 2	2	3	3	60
125	R1863 3	2	3	3	60

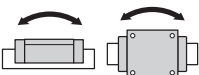
**Technical data**

Size	Mass (kg)	Load capacities <sup>1)</sup> (N)		Torsional moment load capacity <sup>1)</sup> (Nm)		Longitudinal moment load capacity <sup>1)</sup> (Nm)	
							
	m	C	$C_o$	$M_t$	$M_{t0}$	$M_L$	$M_{L0}$
100	42.0	632000	1218000	35300	67900	27200	52400
125	89.8	1020000	1941900	75350	139820	58820	109150

1) Determination of the dynamic load capacities and load moments is based on a travel of 100,000 m according to DIN ISO 14728-1. Often only 50,000 m are actually stipulated. For comparison: Multiply values C,  $M_t$  and  $M_L$  from the table by 1.23.

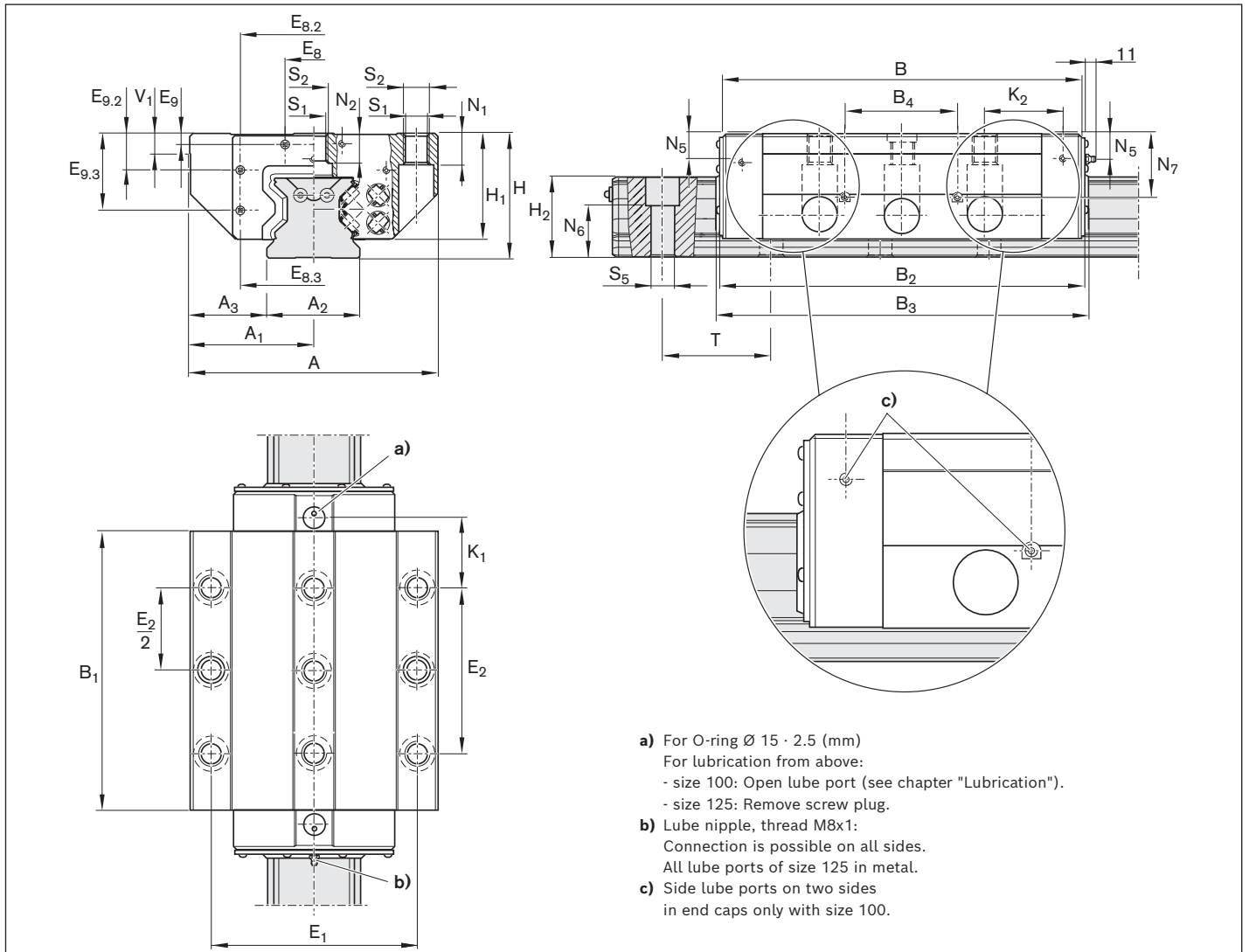
**Dimensions (mm)**

Size	A	A <sub>1</sub>	A <sub>2</sub>	A <sub>3</sub>	B	B <sub>1</sub>	B <sub>2</sub>	B <sub>3</sub>	B <sub>4</sub>	E <sub>1</sub>	E <sub>2</sub>	E <sub>8</sub>	E <sub>8.2</sub>	E <sub>8.3</sub>	E <sub>9</sub>	E <sub>9.2</sub>	E <sub>9.3</sub>
<b>100</b>	250	125	100	75.0	380.5	288	385.5	393.5	–	200	230	64	130	162.6	9	29.4	70
<b>125</b>	320	160	125	97.5	476	360	482	491.5	150	270	205	80	205	205.0	12	40.0	92

Size	H	H <sub>1</sub>	H <sub>2</sub> <sup>1)</sup>	K <sub>1</sub>	K <sub>2</sub>	N <sub>1</sub>	N <sub>2</sub>	N <sub>5</sub>	N <sub>6</sub> <sup>20.5</sup>	N <sub>7</sub>	S <sub>1</sub>	S <sub>2</sub>	S <sub>5</sub>	T	V <sub>1</sub>
<b>100</b>	120	105.0	87.3	46.0	51.9	30	22	17.5	55.0	–	17.5	M20	26	105	20
<b>125</b>	160	135.5	115.3	102.5	102.5	45	29	29.0	74.5	92	25.0	M27	33	120	25

1) Dimension H<sub>2</sub> with cover strip

2) Dimension T = Rail separation of the roller guide rail

**⚠** Due to the manufacturing process, some surfaces (e.g. bores, countersinks, inner contours, contact points, etc.) may not be coated.

## Heavy-duty roller guide rail SNS with cover strip made of steel R1835 .6. .. / Resist CR R1865 .6. ..

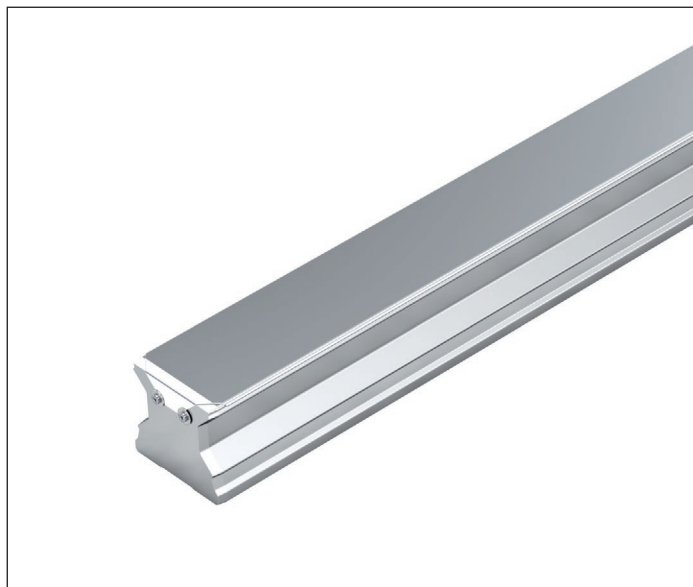

**For mounting from above, with cover strip made of corrosion-resistant spring steel per EN 10088 (with threaded mounting holes on end faces)**

### Notes

- ▶ Secure the cover strip.
- ▶ Screws and washers included in the scope of delivery.
- ▶ Observe the instruction for mounting!
- ▶ Please request the "Mounting instructions for Roller Rail Systems" and "Mounting instructions for cover strip".
- ▶ Composite roller guide rail also available.

### Material numbers of heavy-duty roller guide rails made of steel

Size	Roller guide rail with size	Accuracy class			Number of sections		Hole spacing T (mm)	Recommended rail lengths
		H	P	SP	One-piece	Composite		$L = n_B \cdot T - 7 \text{ mm}$ Maximum number of bores $n_B$
100	R1835 26	3	2	1	61, ....	6., ...	105	35
125	R1835 36	3	2	-	61, ....	6., ...	120	22

### Material numbers of heavy-duty roller guide rails Resist CR

Size	Roller guide rail with size	Accuracy class			Number of sections		Hole spacing T (mm)	Recommended rail lengths
		H			One-piece	Composite		$L = n_B \cdot T - 7 \text{ mm}$ Maximum number of bores $n_B$
100	R1865 26	3			71, ....	7., ...	105	35
125	R1865 36	3			71, ....	7., ...	120	22

#### Ordering example 1

(to  $L_{\max}$ )

Options:

- ▶ Roller guide rail SNS
- ▶ Size 125
- ▶ Accuracy class P
- ▶ One-piece
- ▶ Rail length  
L = 1637 mm

Material number:

R1835 362 61, 1637 mm

#### Ordering example 2

(above  $L_{\max}$ )

Options:

- ▶ Roller guide rail SNS
- ▶ Size 125
- ▶ Accuracy class P
- ▶ **Multi-part (2 parts)**
- ▶ Rail length  
L = 5033 mm

Material number:

R1835 362 62, 5033 mm

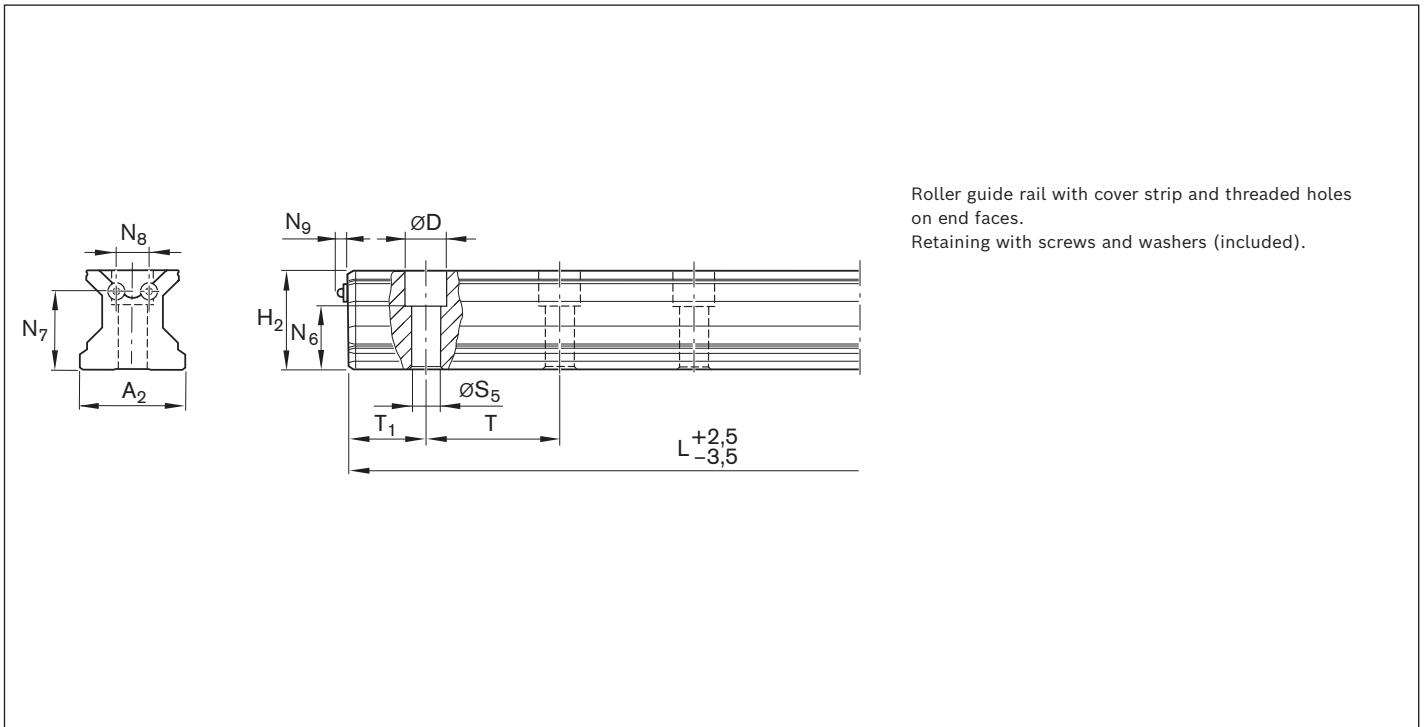

**Dimensions (mm)**

Size	A <sub>2</sub>	D	H <sub>2</sub> <sup>1)</sup>	L <sub>max</sub>	N <sub>6</sub> <sup>±0.5</sup>	N <sub>7</sub>	N <sub>8</sub>	N <sub>9</sub>	S <sub>5</sub>	T <sub>1 min</sub> <sup>2)</sup>	T <sub>1 max</sub>	T <sub>15</sub> <sup>3)</sup>	T	Mass (kg/m)
<b>100</b>	100	40	87.3	3885 <sup>4)</sup>	55.0	65	28	4.8	26	35	70	49.0	105	42.5
<b>125</b>	125	49	115.3	2760 <sup>5)</sup>	74.5	91	38	4.8	33	40	80	56.5	120	75.6

- 1) Dimension H<sub>2</sub> with cover strip 0.3 mm
- 2) When undercutting T<sub>1 min</sub>, no end-face thread possible.  
Secure the cover strip! Observe the instruction for mounting!
- 3) Preferred dimension T<sub>15</sub> with tolerances +1/-1.5
- 4) L<sub>max</sub> for heavy-duty roller guide rails Resist CR: 2500 mm
- 5) L<sub>max</sub> for heavy-duty roller guide rails Resist CR: 2000 mm

**⚠** Due to the manufacturing process, some surfaces (e.g. bores, countersinks, inner contours, contact points, etc.) may not be coated.

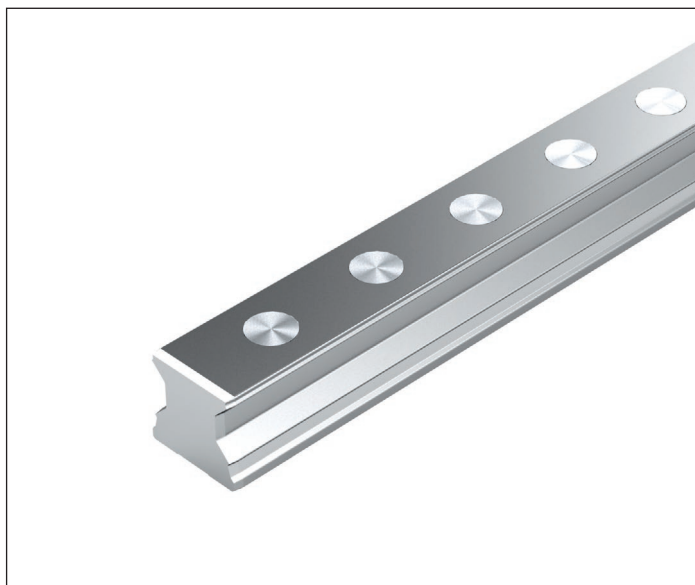
# Heavy-duty roller guide rails SNS with steel caps R1836 .5. ...



**For bolting from above, for steel caps (not included in the scope of delivery)**

### Notes

- ▶ Steel caps are not included in the scope of delivery of the roller guide rails. Order separately (see "Accessories for roller guide rails")
- ▶ The mounting tool is to be ordered separately (see "Accessories for roller guide rails")!
- ▶ Observe the instruction for mounting!
- ▶ Please ask for the "Mounting Instructions for Roller Rail Systems".
- ▶ Composite roller guide rail also available.

### Material numbers

Size	Roller guide rail with size	Accuracy class			Number of sections		Hole spacing T (mm)	Recommended rail lengths
		H	P	SP	One-piece	Composite		$L = n_B \cdot T - 7 \text{ mm}$ Maximum number of bores $n_B$
100	R1836 25	3	2	1	31, ...	3., ...	105	35

#### Ordering example 1 (to $L_{\max}$ )

Options:

- ▶ Roller guide rail SNS
- ▶ Size 100
- ▶ Accuracy class P
- ▶ One-piece
- ▶ Rail length  
L = 1673 mm

Material number:

R1836 352 31, 1673 mm

#### Ordering example 2 (above $L_{\max}$ )

Options:

- ▶ Roller guide rail SNS
- ▶ Size 100
- ▶ Accuracy class P
- ▶ **Multi-part (2 parts)**
- ▶ Rail length  
L = 5768 mm

Material number:

R1836 352 32, 5768 mm

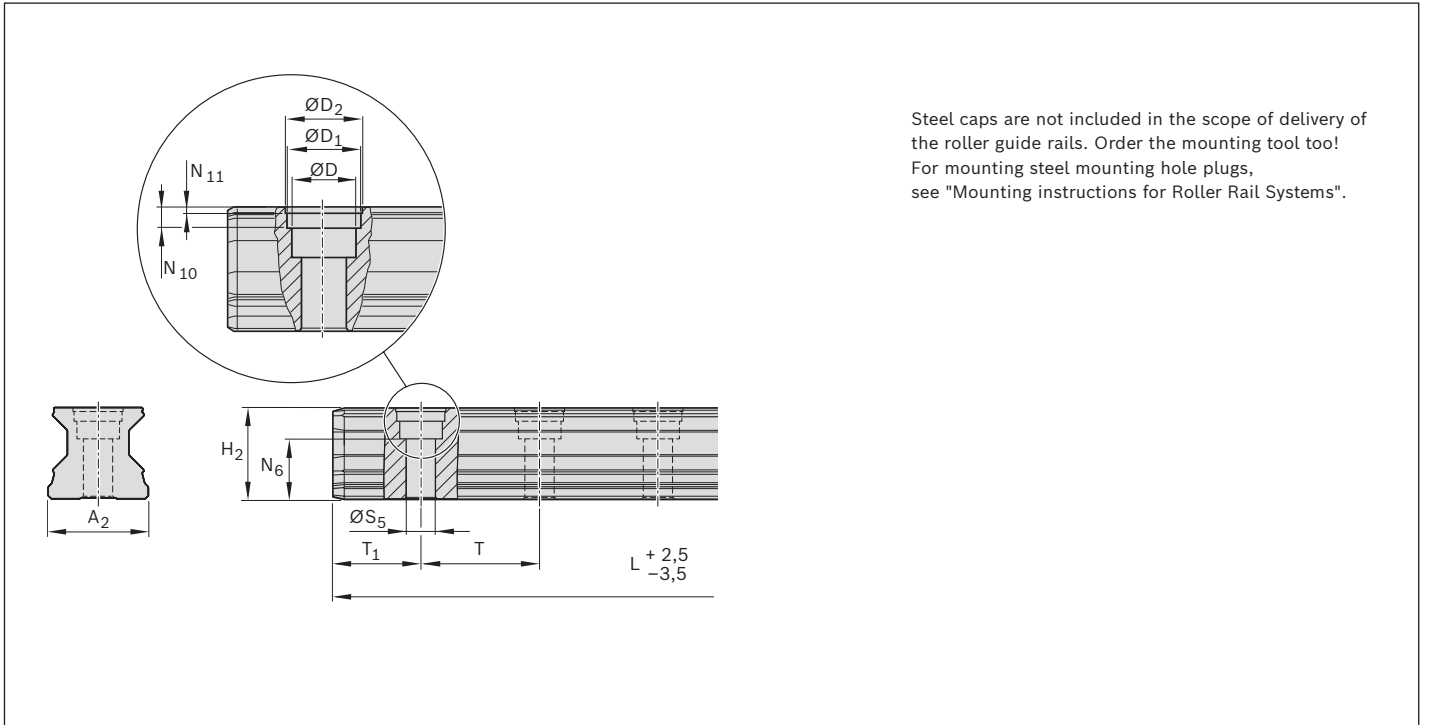

**Dimensions (mm)**

Size	A <sub>2</sub>	D	D <sub>1</sub>	D <sub>2</sub>	H <sub>2</sub>	L <sub>max</sub>	N <sub>6</sub> <sup>±0.5</sup>	N <sub>10</sub>	N <sub>11</sub>	S <sub>5</sub>	T <sub>1 min</sub>	T <sub>1 max</sub>	T <sub>1 S</sub> <sup>1)</sup>	T	Mass (kg/m)
100	100	40	43.55	46	87.00	3986	55.00	9.0	1.60	26	35	70	49.00	105	42.5

1) Preferred dimension T<sub>1S</sub> with tolerances +1.0/-1.5

# Overview of Accessories for Roller runner blocks

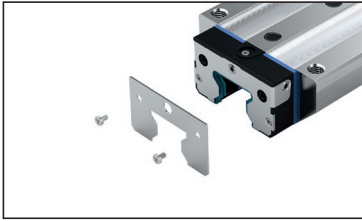
**Cover plate wiper**



**Lube nipple**

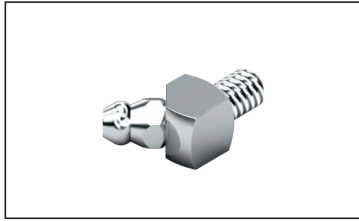

**FKM seal**

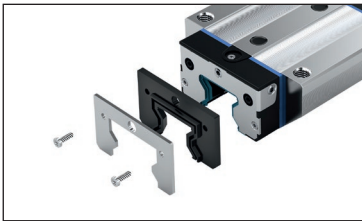

**Lube fittings**

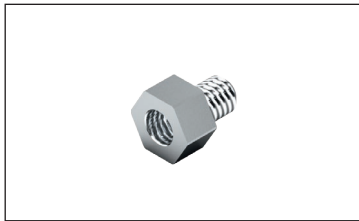

**FKM seal set**



**O-rings**



**Front lube unit**



**Bellows**

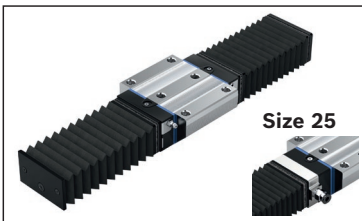

**Lubrication plate for size 25**

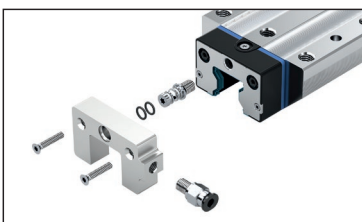

# Cover plate wiper

## R1820 .1. 3.

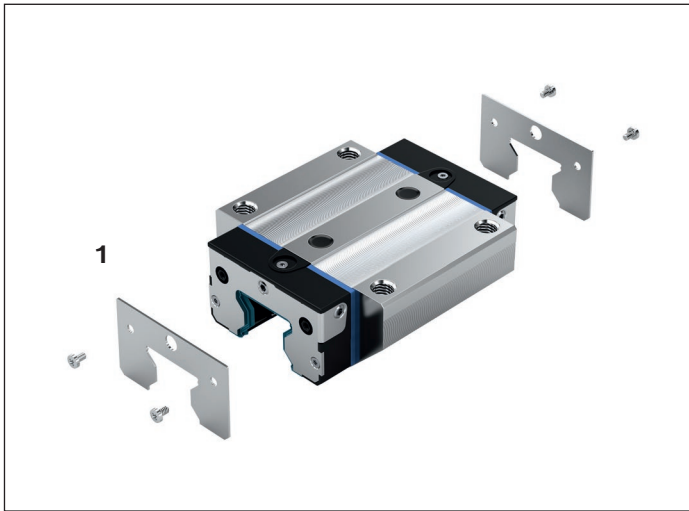

For mounting on roller runner blocks for roller guide rails with cover strip

### 1 Cover plate wiper

- Material: Rust-free spring steel in as per DIN EN 10088
- Version: bright

### Instruction for mounting

When mounting, ensure an even gap between the roller guide rail and the cover plate wiper.

With end-face lube connection:

Use special lube nipple or adapter (see "Accessories").

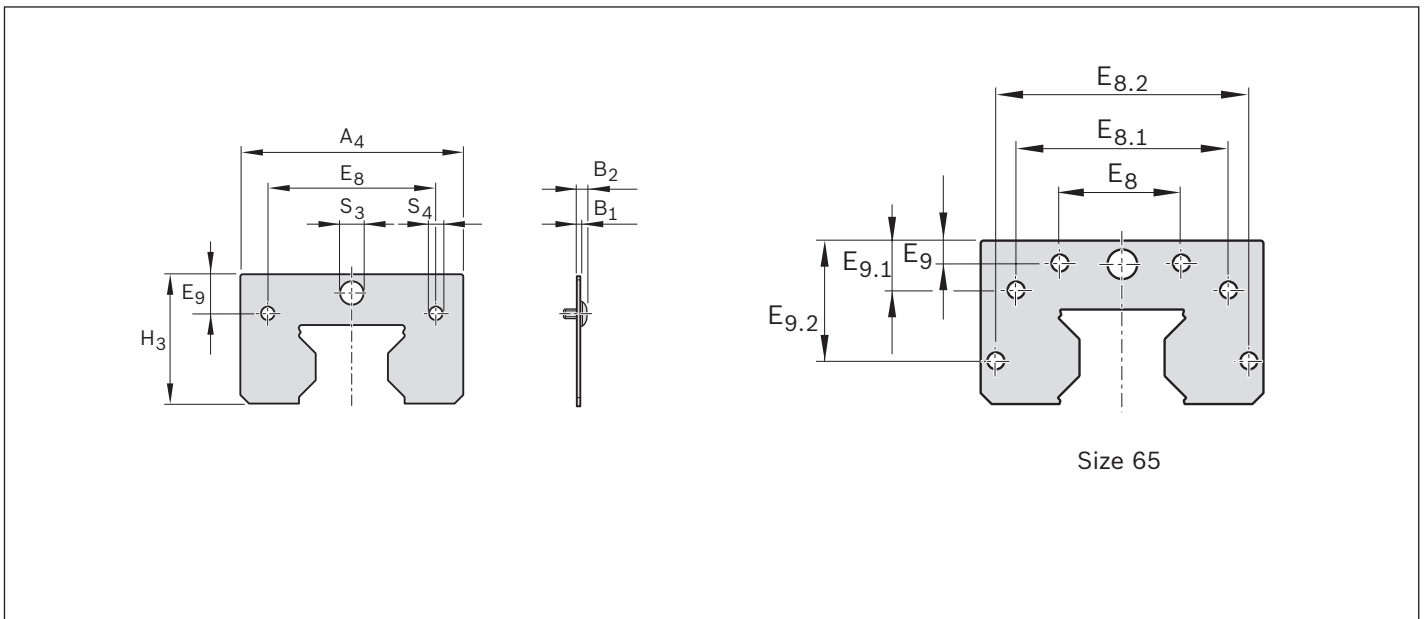

### Material numbers and dimensions

Size	Material number	Dimensions (mm)												Mass (g)
		A <sub>4</sub>	H <sub>3</sub>	B <sub>1</sub>	B <sub>2</sub>	E <sub>8</sub>	E <sub>8.1</sub>	E <sub>8.2</sub>	E <sub>9</sub>	E <sub>9.1</sub>	E <sub>9.2</sub>	S <sub>3</sub>	S <sub>4</sub>	
25	R1820 210 30	45.40	29.15	1.00	3.00	33.40	-	-	7.45	-	-	∅ 7.00	∅ 4.00	7
35	R1820 310 30	67.40	39.70	1.00	3.00	50.30	-	-	12.05	-	-	∅ 7.00	∅ 4.00	15
45	R1820 410 30	80.40	49.70	2.00	5.10	62.90	-	-	15.70	-	-	∅ 7.00	∅ 5.00	44
55	R1820 510 30	92.80	56.70	2.00	5.80	74.20	-	-	17.80	-	-	∅ 7.00	∅ 6.00	52
65	R1820 610 30	118.40	73.90	2.00	5.10	35.00	93.00	-	8.00	24.70	-	∅ 7.00	∅ 5.00	104

# FKM seal R1810 .2. 3.

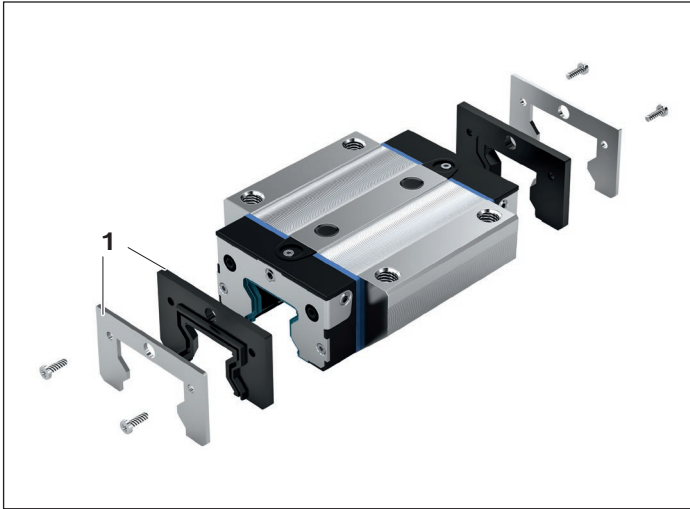

For mounting at the roller runner block

**1** Two-piece FKM seal

- Material: Stainless steel plus FKM seal

Special feature: Simple mounting and dismounting at fastened roller guide rail. Observe the mounting instructions.

Instruction for mounting:

The fastening screws are included.

Max. tightening torque 0.4 Nm

With end-face lube connection: Use special lube nipple or adapter (see "Accessories").

It is possible to combine with additional cover plate wiper.

For sizes 35 to 65, use the FKM seal set and sheet cover plate wiper (see following page).

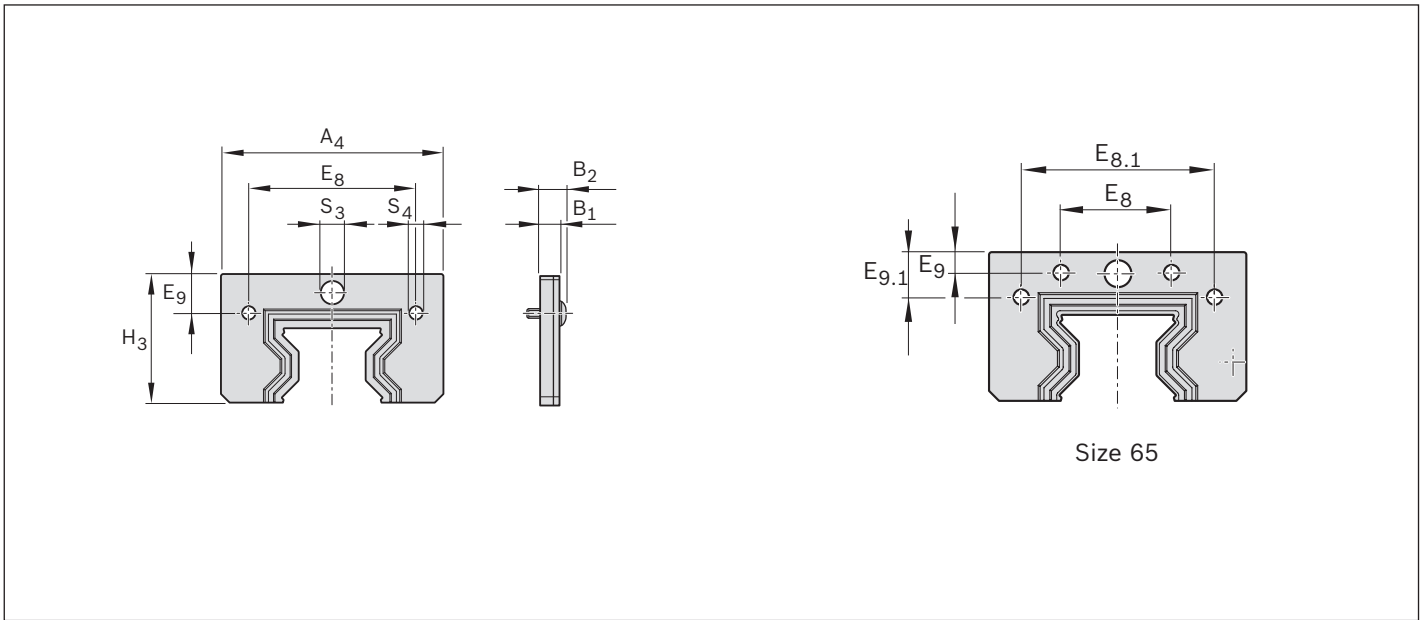

### Material numbers and dimensions

Size	Material number	Dimensions (mm)										Mass (g)
		A <sub>4</sub>	H <sub>3</sub>	B <sub>1</sub>	B <sub>2</sub>	E <sub>8</sub>	E <sub>8.1</sub>	E <sub>9</sub>	E <sub>9.1</sub>	S <sub>3</sub>	S <sub>4</sub>	
25	R1810 220 30	45.40	29.15	6.00	8.00	33.40	-	7.45	-	Ø 7.00	Ø 4.00	18
35	R1810 320 30	67.40	39.70	6.00	8.00	50.30	-	12.05	-	Ø 7.00	Ø 4.00	40
45	R1810 420 30	80.40	49.70	6.00	9.10	62.90	-	15.70	-	Ø 7.00	Ø 5.00	62
55	R1810 520 30	92.80	56.70	6.00	9.80	74.20	-	17.80	-	Ø 7.00	Ø 6.00	76
65	R1810 620 30	118.40	73.90	6.00	9.10	93.00	93.00	8.00	24.70	Ø 7.00	Ø 5.00	146

## FKM seal set R1810 .2. 7.

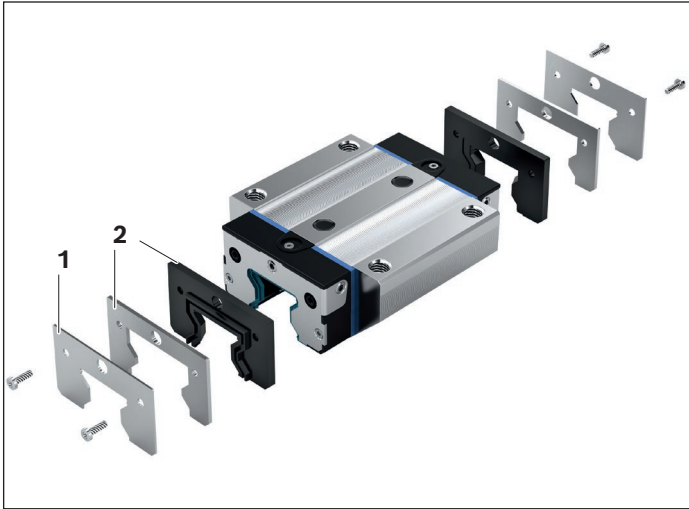

For mounting at the roller runner block  
FKM seal and cover plate wiper:

- 1 Cover plate wiper
- 2 Two-piece FKM seal

Instruction for mounting:

The fastening screws are included.

Max. tightening torque 0.4 Nm

With end-face lube connection:

Use special lube nipple or adapter (see "Accessories").

Observe the mounting instructions.

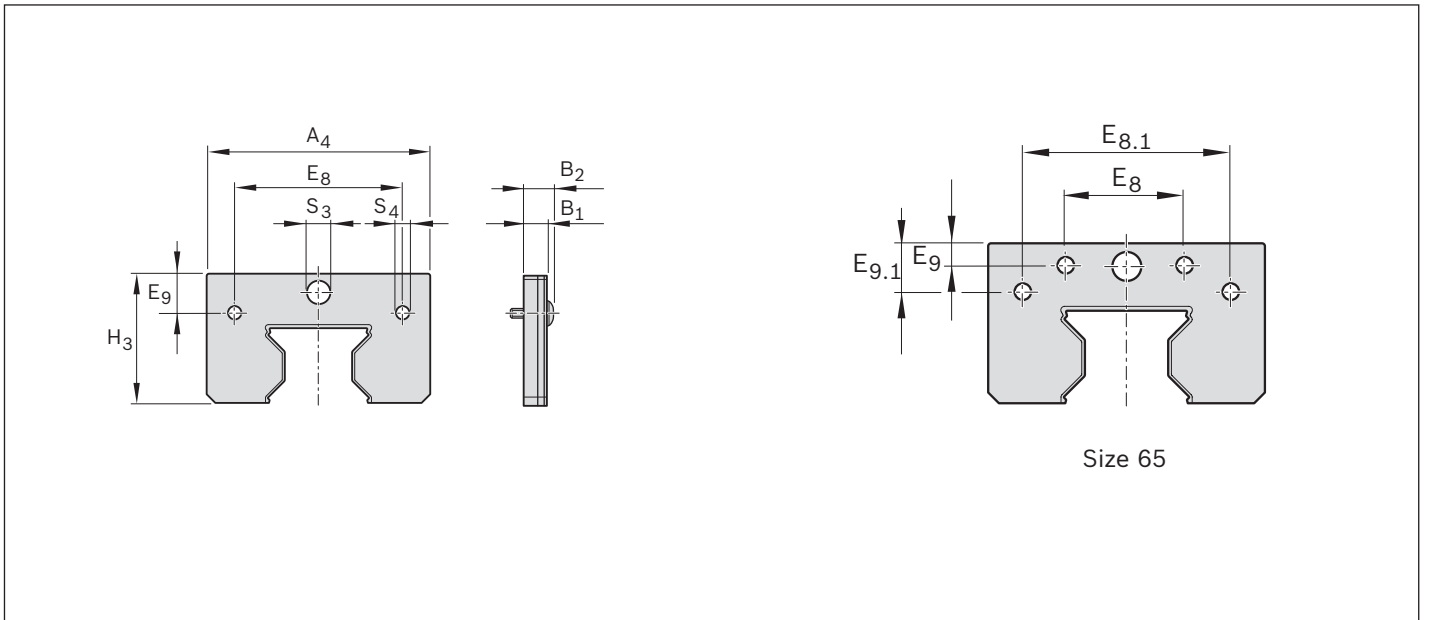

### Material numbers and dimensions

Size	Material number	Dimensions (mm)										Mass (g)
		A <sub>4</sub>	H <sub>3</sub>	B <sub>1</sub>	B <sub>2</sub>	E <sub>8</sub>	E <sub>8.1</sub>	E <sub>9</sub>	E <sub>9.1</sub>	S <sub>3</sub>	S <sub>4</sub>	
25	R1810 220 70	45.40	29.15	7.00	9.00	33.40	–	7.45	–	∅ 7.00	∅ 4.00	25
35	R1810 320 70	67.40	39.70	7.00	9.00	50.30	–	12.05	–	∅ 7.00	∅ 4.00	55
45	R1810 420 70	80.40	49.70	8.00	11.10	62.90	–	15.70	–	∅ 7.00	∅ 5.00	106
55	R1810 520 70	92.80	56.70	8.00	11.80	74.20	–	17.80	–	∅ 7.00	∅ 6.00	128
65	R1810 620 70	118.40	73.90	8.00	11.10	93.00	93.00	8.00	24.70	∅ 7.00	∅ 5.00	250

## Front lube units

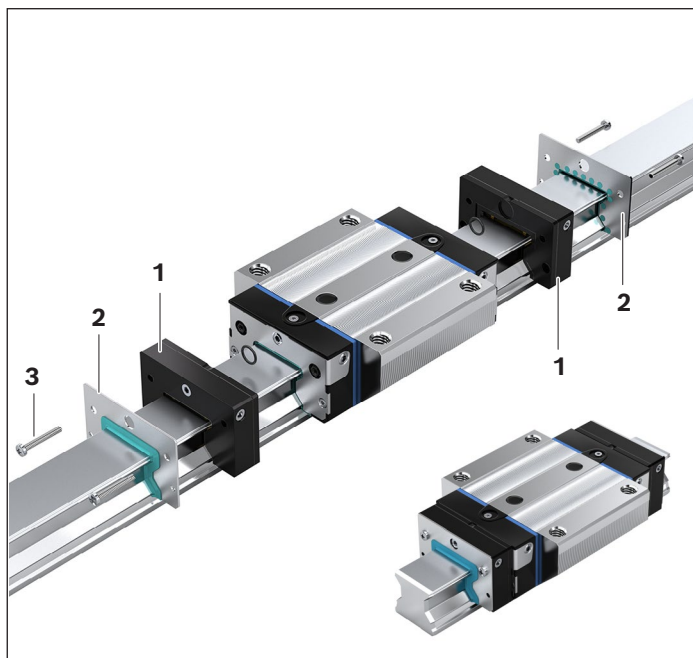

### Advantages for mounting and operation

- ▶ For a travel distance of up to 5000 km without re-lubrication
- ▶ Roller runner block only needs initial lubrication with grease
- ▶ Front lube units on both sides of the roller runner block
- ▶ Low lubricant loss
- ▶ Reduced oil consumption
- ▶ No lubrication lines
- ▶ Max. operating temperature 60°C
- ▶ Front lube unit can be refilled using the lube nipple on the end-face or at the side.
- ▶ Size 25:  
Lube connection on the end-face of the front lube unit is suitable for the grease lubrication of the roller runner block. For this purpose, a lube pin is attached. For a detailed instruction for mounting with size 25, please refer to the Roller Rail System instruction.

**⚠** Before mounting the front lube unit, an initial lubrication of the roller runner blocks with **grease lubricant** is required! See chapter Lubrication

### Mounting of front lube units

The coated screws required for attachment additional front seals are supplied along with the unit.

1. In each case, mount a front lube unit (1) on both sides of the roller runner block!
2. Do not remove the roller runner block from the rail!
3. Slide on the front lube units (1) and front seals (2) and align them on the roller runner block.
4. Tighten screws (3) to tightening torque  $M_A$  (see table).

### Notes

The coated screws required for attachment on the roller runner block, additional front seals and lube nipples are supplied along with the unit. The front lube units are already filled with oil (Mobil SHC 639) and can be mounted immediately after basic lubrication of the Roller runner blocks.

### Lubricant distribution

Due to the special structural design of the lubricant distribution, lubrication occurs primarily where it is needed: directly on the running tracks and the top surfaces of the roller guide rails.

Size	Item 3	Tightening torque $M_A$ (Nm)
25	M3 x 15	0.7
35	M3 x 22	0.7
45	M4 x 25	1.0
55	M5 x 30	1.3
65	M4 x 30	1.0

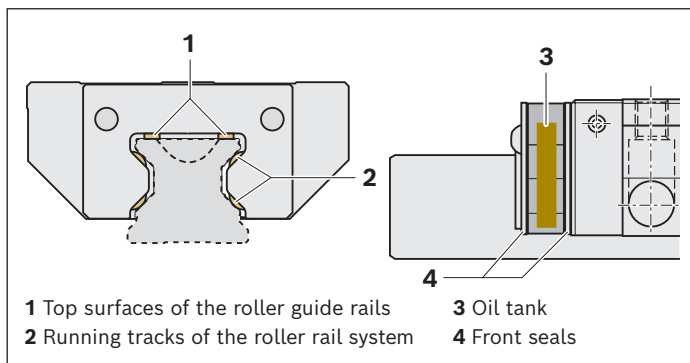

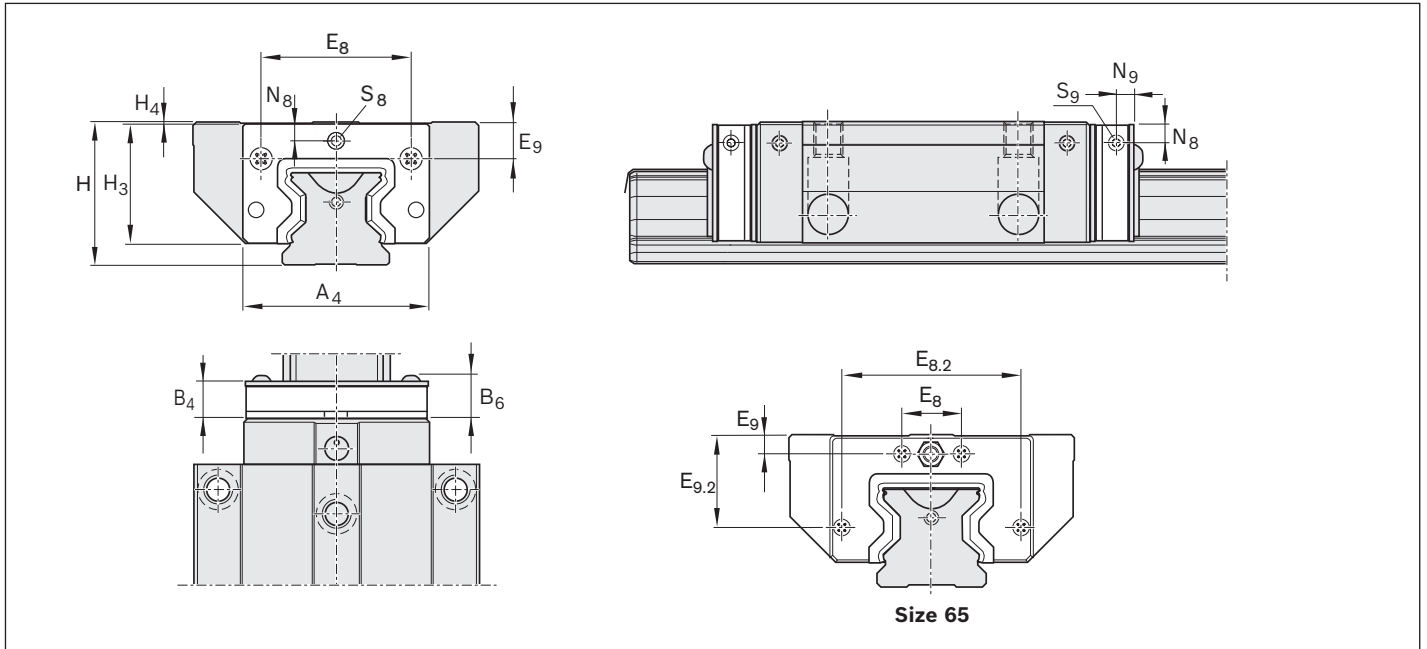
**Design and technical data**

**Size 65**

Size	Material numbers	Dimensions (mm)														Oil (cm <sup>3</sup> )	Mass (g)
		A <sub>4</sub>	B <sub>4</sub>	B <sub>6</sub>	E <sub>8</sub>	E <sub>8,2</sub>	E <sub>9</sub>	E <sub>9,2</sub>	H	H <sub>3</sub>	H <sub>4</sub>	N <sub>8</sub>	N <sub>9</sub>	S <sub>8</sub>	S <sub>9</sub>		
25	R1810 225 00	44.0	13.0	15.5	33.4	-	8.40 <sup>1)</sup> 12.40 <sup>2)</sup>	-	36 <sup>1)</sup> 40 <sup>2)</sup>	29.2	0.50 <sup>1)</sup> 4.50 <sup>2)</sup>	5.00 <sup>1)</sup> 9.00 <sup>2)</sup>	-	M6	-	2.6	24
35	R1810 325 00	64.0	16.5	19.0	50.3	-	13.10 <sup>1)</sup> 20.10 <sup>2)</sup>	-	48 <sup>1)</sup> 55 <sup>2)</sup>	40.0	0.75 <sup>1)</sup> 7.75 <sup>2)</sup>	6.25 <sup>1)</sup> 13.25 <sup>2)</sup>	5.5	M6	M6	8.3	46
45	R1810 425 00	78.0	18.5	21.8	62.9	-	16.70 <sup>1)</sup> 26.75 <sup>2)</sup>	-	60 <sup>1)</sup> 70 <sup>2)</sup>	50.0	0.75 <sup>1)</sup> 10.75 <sup>2)</sup>	7.25 <sup>1)</sup> 17.25 <sup>2)</sup>	7.5	M6	M6	13.8	88
55	R1810 525 00	91.5	20.3	24.3	74.2	-	18.85 <sup>1)</sup> 28.95 <sup>2)</sup>	-	70 <sup>1)</sup> 80 <sup>2)</sup>	56.3	0.75 <sup>1)</sup> 10.75 <sup>2)</sup>	8.25 <sup>1)</sup> 18.25 <sup>2)</sup>	9.0	M6	M6	22.8	122
65	R1810 625 00	119.0	21.0	24.3	35.0	106	9.30	55.0	90	74.8	0.75	8.55	8.5	M6	M6	47.6	225

1) Dimension with regard to mounting surface of roller runner block for a standard higher version

2) Dimension with regard to mounting surface of roller runner block for a higher version

## Front lube units

### Lubrication intervals for roller runner blocks with front lube units

- ▶ Check the front lube units once the travel distance in figure 1 is attained.

Upon reaching the travel distance according to image 1 or after no more than 3 years, we recommend replacing the Front lube units and re-lubricating the roller runner block prior to mounting the new front lube unit.

Under clean operating conditions, the roller runner blocks (sizes 35 to 65 laterally and size 25 end face) can be re-lubricated with grease (Dynalub 510) (see table 1).

- ⚠ If other lubricants are used, this may lead to a reduction in the lubrication intervals, performance losses in short stroke applications and the load capacities. Possible chemical interactions between the plastic materials, lubricants and preservative agents must also be taken into account.
- ⚠ The recommended lubrication intervals depend on environmental factors, load and load type. Examples of environmental factors include swarf, mineral abrasion (or similar), solvent and temperature. Examples of loads and stress types are oscillations, shocks and tilting.
- ⚠ The conditions of use are unknown to the manufacturer. Only the user's own trials or accurate monitoring can yield safety across lubrication intervals.
- ⚠ No water-based coolant/lubricant on the roller guide rails and roller runner block!

**Table 1**

Size	Relubrication (cm <sup>3</sup> )
25	0.8
35	0.9
45	1.0
55	2.5
65	2.7

**Load-dependent lubrication intervals for roller runner block with front lube units****Sizes 25 to 65****This applies to the following conditions:**

- ▶ Roller runner block lubricants:  
Dynalub 510 (NLGI 2 grease) or, alternatively, Castrol Longtime PD 2 (NLGI 2 grease)
- ▶ Front lube units lubricant:  
Mobil SHC 639 (synthetic oil)
- ▶ Maximum speed:  $v_{\max} = 2 \text{ m/s}$
- ▶ No media pressurization
- ▶ Standard seals
- ▶ Ambient temperature:  $T = 10 - 40 \text{ }^\circ\text{C}$

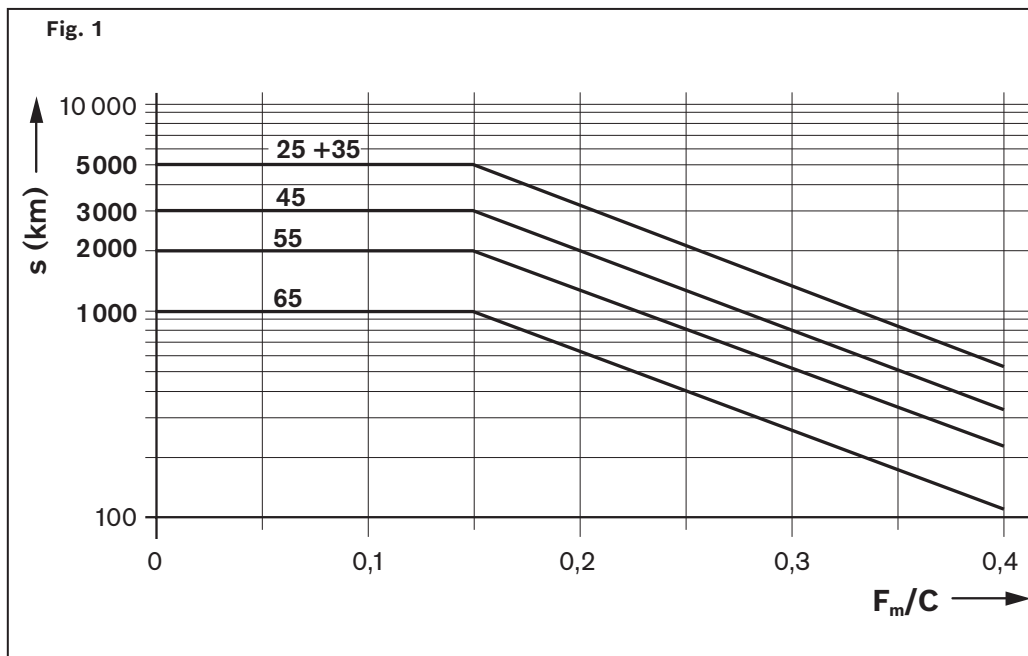
**Note**

The load ratio  $F/C$  is the quotient of the equivalent dynamic load on bearing  $F$  (making allowance for the preload for C2 or C3) divided by the dynamic load capacity  $C$  (see "General Technical Data and Calculations").

**Key to illustration**

$s$  = Lubrication interval as travel distance (km)  
 $C$  = Dynamic load capacity (N)  
 $F_m/C$  = Dynamic equivalent load on bearing (N)

# Bellows

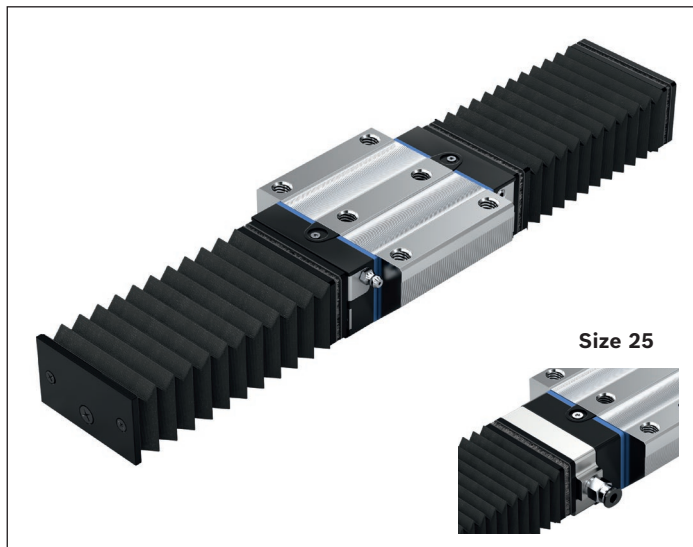

## Bellows

- ▶ Material: Polyurethane-coated polyester fabric.
- ▶ Size 25: Aluminum lubrication plate. The lube nipple of the roller runner block can be used.

## Heat-resistant bellows

- ▶ Material: Nomex fabric, metalized

### Temperature stability

- ▶ Non combustible, non flammable
- ▶ Resistant to sparks, welding spatter and hot chips.
- ▶ The protective metal coating can withstand peak temperatures of up to 200 °C.
- ▶ Operating temperature for the total bellows: 100 °C.

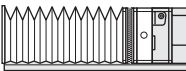
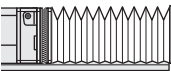
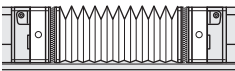
Size	 <b>Type 1: with lubrication plate and end plate</b>	 <b>Type 2: with fastening frame and end plate</b>	 <b>Type 3: with 2 lubrication plates</b>
<b>Material number, fold count</b>			
<b>Standard bellows</b>			
<b>25</b>	R1820 241 00, ...	R1820 202 00, ...	R1820 243 00, ...
<b>35</b>	-	R1820 302 00, ...	-
<b>45</b>	-	R1820 402 00, ...	-
<b>55</b>	-	R1820 502 00, ...	-
<b>65</b>	-	R1820 602 00, ...	-
<b>Heat-resistant bellows</b>			
<b>25</b>	R1820 271 00, ...	R1820 252 00, ...	R1820 273 00, ...
<b>35</b>	-	R1820 352 00, ...	-
<b>45</b>	-	R1820 452 00, ...	-
<b>55</b>	-	R1820 552 00, ...	-
<b>65</b>	-	R1820 652 00, ...	-

**Ordering examples****Bellows**

- ▶ Size 35, type 2
- ▶ Number of folds: 36

**Ordering data**

Material number, fold count: R1820 302 00, 36 folds

**Heat-resistant bellows**

- ▶ Size 35, type 2
- ▶ Number of folds: 36

**Ordering data**

Material number, fold count: R1820 352 00, 36 folds

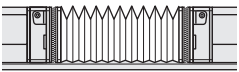
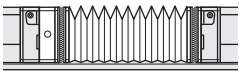
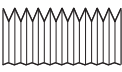
Size			
	<b>Type 4: with 2 fastening frames</b>	<b>Type 5: with lubrication plate and fastening frame</b>	<b>Type 9: Loose bellows (spare part)</b>
<b>Material number, fold count</b>			
<b>Standard bellows</b>			
<b>25</b>	R1820 204 00, ...	R1820 245 00	R1600 209 00
<b>35</b>	R1820 304 00, ...	–	R1600 309 00
<b>45</b>	R1820 404 00, ...	–	R1600 409 00
<b>55</b>	R1820 504 00, ...	–	R1600 509 00
<b>65</b>	R1820 604 00, ...	–	R1600 609 00
<b>Heat-resistant bellows</b>			
<b>25</b>	R1820 254 00, ...	R1820 275 00	R1600 259 00
<b>35</b>	R1820 354 00, ...	–	R1600 359 00
<b>45</b>	R1820 454 00, ...	–	R1600 459 00
<b>55</b>	R1820 554 00, ...	–	R1600 559 00
<b>65</b>	R1820 654 00, ...	–	R1600 659 00

# Bellows

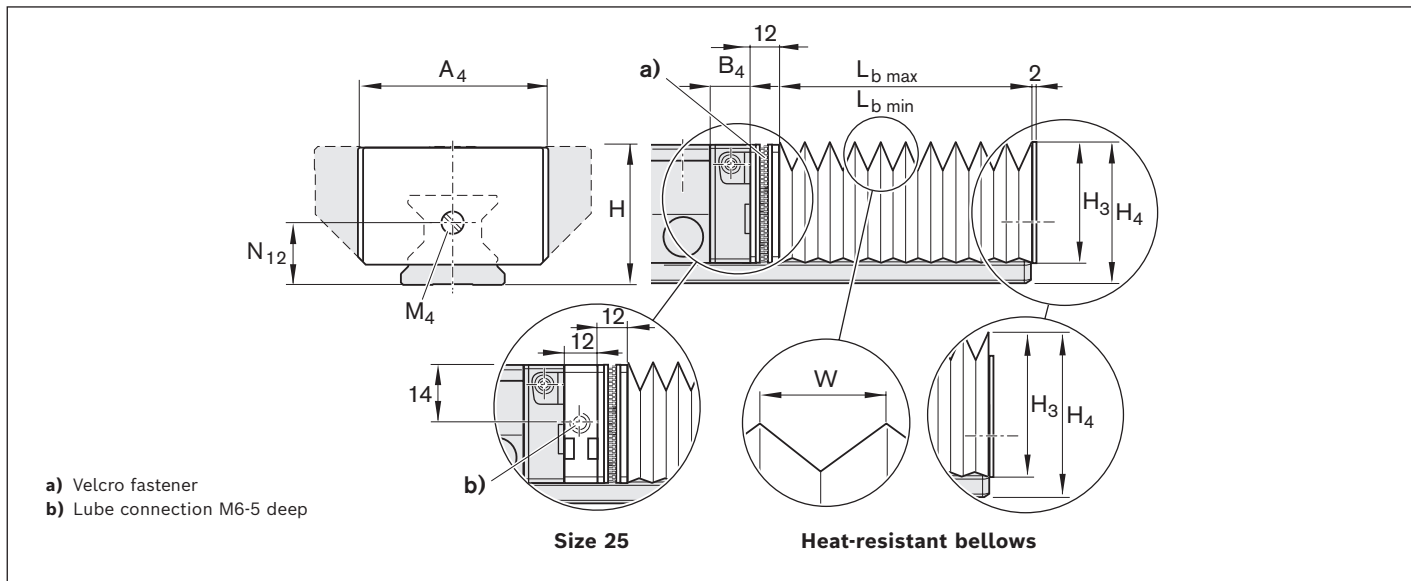

Size	Bellows dimensions (mm)								Factor U
	A <sub>4</sub>	B <sub>4</sub>	H	H <sub>3</sub>	H <sub>4</sub>	N <sub>12</sub>	M <sub>4</sub>	W	
25	45	13,0	36	28,5	35,0	15	M4	12,9	1,32
35	64	16,5	48	39,0	47,0	22	M4	19,9	1,18
45	83	18,5	60	49,0	59,0	30	M4	26,9	1,13
55	96	20,3	70	56,0	69,0	30	M4	29,9	1,12
65	120	21,0	90	75,0	89,0	40	M4	40,4	1,08

Size	Dimensions of bellows, heat-resistant (mm)								Factor U
	A <sub>4</sub>	B <sub>4</sub>	H	H <sub>3</sub>	H <sub>4</sub>	N <sub>12</sub>	M <sub>4</sub>	W	
25	62	13,0	36	39,0	44,5	15	M4	25,9	1,25
35	74	16,5	48	46,0	54,0	22	M4	29,9	1,21
45	88	18,5	60	54,0	64,0	30	M4	32,9	1,18
55	102	20,3	70	62,0	75,0	30	M4	37,9	1,16
65	134	21,0	90	86,0	99,0	40	M4	52,4	1,11

## Instruction for mounting for bellows

The bellows are pre-assembled. The fastening screws are included. The lube nipple of the roller runner block can be used.

For type 1 and type 2, a thread M4-10 deep, 2 x 45° must be countersunk and placed in the end face of the rail in each case.

For assembly, see "Mounting instructions for bellows".

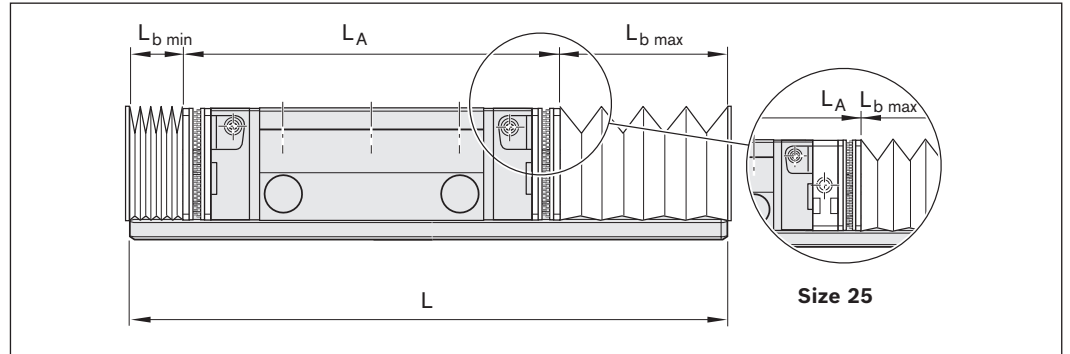
**Calculation**

**Roller guide rail length**

$$1) \quad \begin{aligned} L &= s_{\max} \cdot U + L_A + 30 \\ L_A &= B + 2 \cdot 12 + B_4 \end{aligned}$$

$$2) \quad s_{\max} = \frac{L - L_A - 30}{U}$$

$L$  = Roller guide rail length (mm)  
 $s_{\max}$  = Maximum travel range (mm)  
 $U$  = Calculation factor (-)  
 $L_A$  = Length of ball runner block with attachments (mm)  
 $B$  = Roller runner block length (mm)  
 (see chapter "Roller runner block")  
 $B_4$  = Front uni width (mm)  
 (see chapter "Accessories for roller runner blocks")

**Bellows**

$$\begin{aligned} L_{b \min} &= 1/2 (L - s_{\max} - L_A) \\ L_{b \max} &= L_{b \min} + s_{\max} \\ n &= \frac{L_{b \max}}{W} + 2 \end{aligned}$$

$L_{b \min}$  = Bellow contracted (mm)  
 $L_{b \max}$  = Bellow maximum elongated (mm)  
 $n$  = Number of folds (-)  
 $W$  = Maximum bellow extension (mm)

- 1) At predetermined travel
- 2) With limited installation space

# Bellows

## Bellows mounting instructions

### a) Mounting the bellows at the roller runner block (types 2 and 4), including attachment to the end of the rail (types 1 and 2)

#### Only for types 1 and 2:

1. Before mounting, provide the thread bore at the end face of the roller guide rail (5), see dimensions  $N_7$  and  $S_7$  in the table and the dimension drawing under "instruction for mounting" on the previous page.

#### For types 2 and 4:

1. Remove lube nipples from the front lube port (1), if necessary, and screw them into a lateral lube port (re-lubrication side) (3).
2. Use a set screw (2) to close the open lube port.
3. Remove the upper fastening screw of the cover plate wiper.

4. Mount the fastener (with velcro strip (4) to the roller runner block, using the fastening screws included in the scope of delivery.
5. Push on the bellows.

#### Only for types 1 and 2:

1. After mounting, screw on the bellows to the end of the rail (5).

### b) Only size 25: Mounting of the lubrication plate and bellows (types 1, 3 and 5)

#### Notes

With size 25, the lube connection is covered by the bellows. Therefore, for re-lubrication, a lubrication plate is to be mounted at least on one side of the roller runner block. The lubrication plate can be turned around.

Thus, lubricant can be introduced from any desired side.

1. Remove the lube nipple (1) or set screw (2) from the lube port of the roller runner block (re-lubrication side).
2. Screw the lube nipple (3) in on the side of the lubrication plate (6).
3. Insert the round sealing ring (7) into the groove.
4. Screw the lubrication plate (6) together with the fastening frame (4) onto the roller runner block.
5. Close the lube port that is no longer needed with a set screw.

⚠ Set screws must be flush with the external surface of the lubrication plate!

#### For all types:

#### Velcro fastener for the fastening frame (4)

#### Connect the velcro fastener:

1. Attach the velcro fastener of the bellows (8) on one side of the fastening frame (4).
2. Ensure the correct position!
3. Strongly press the bellows against the fastening frame!

#### Loosen the velcro fastener:

4. Attach a flat object laterally at the velcro fastener (ideally in a corner).
  5. Carefully separate the Velcro fastener.
- ⚠ Do not shear off the Velcro fastener!

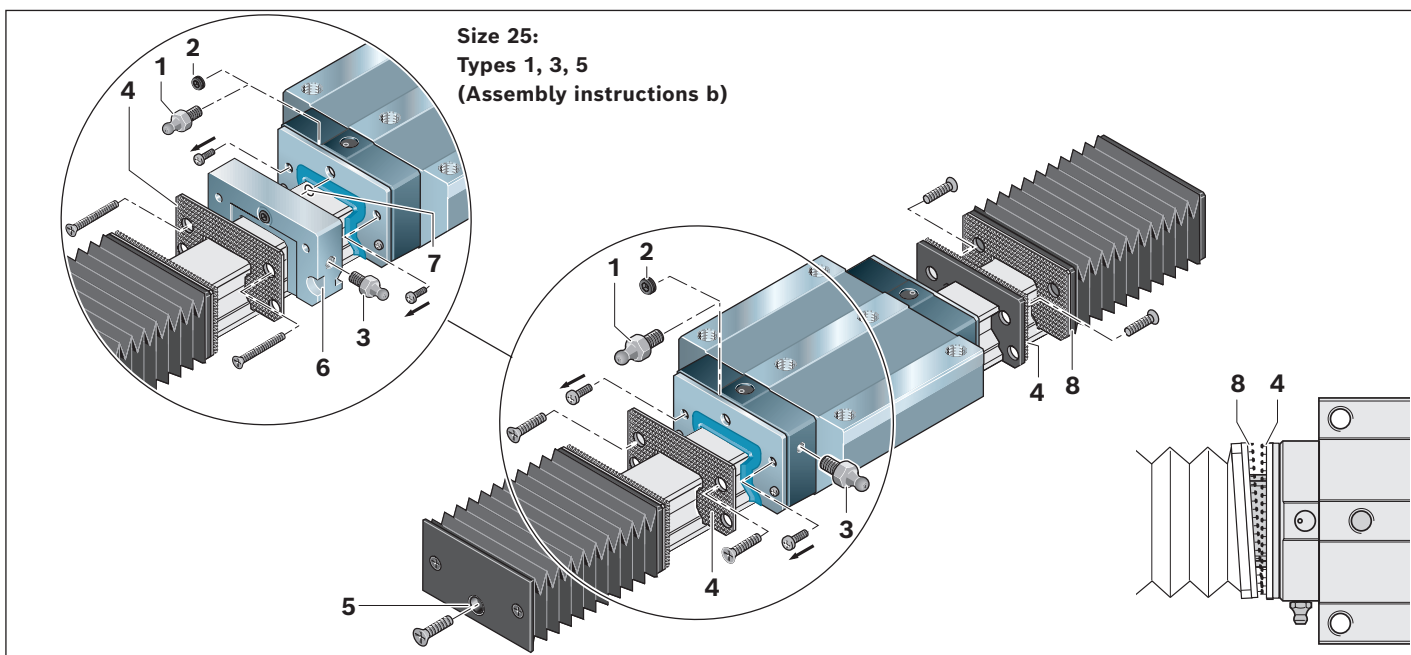

## Lubrication plate for size 25

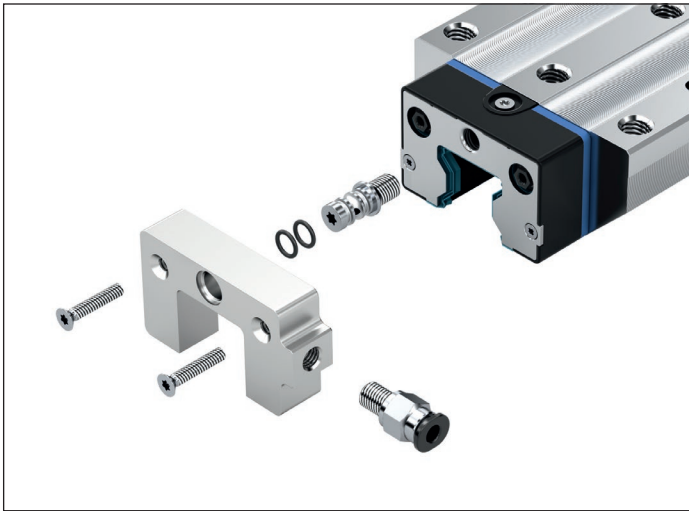

### Lubrication plate for standard lube nipples

► Material: Aluminum

#### Instruction for mounting:

Those parts needed for the attachment to the Runner Block are included.

The lube nipples of the Runner Block can be used. For mounting, see the "Instructions for Roller Rail Systems".

#### Note

When using the lubrication plate, an increased initial lubrication quantity is required.

In this respect, please refer to the notes in the chapter "Lubrication RSHP".

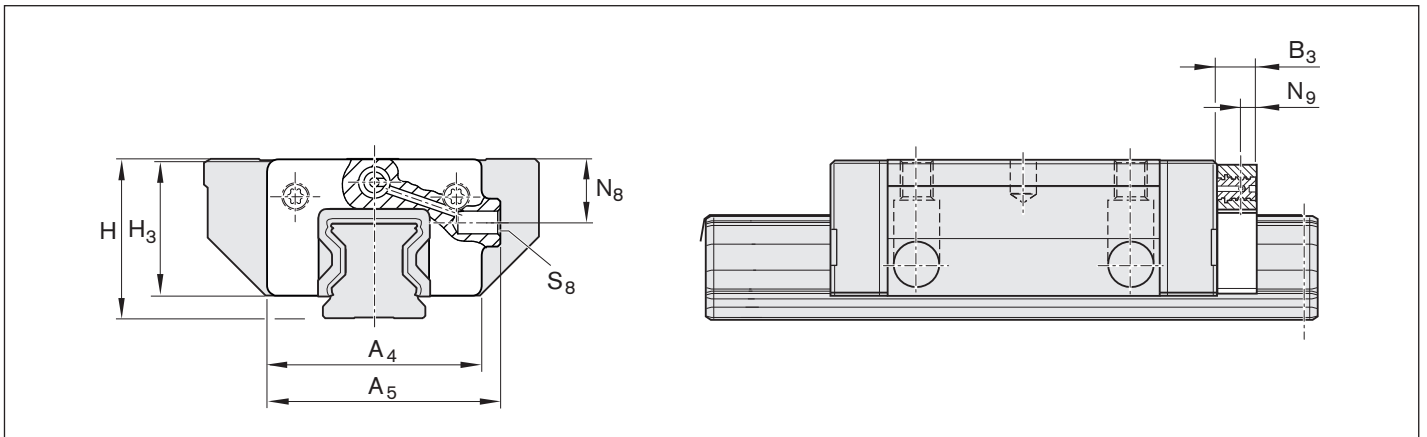

Size	Material numbers	Dimensions (mm)										Mass (g)
		A <sub>4</sub>	A <sub>5</sub>	B <sub>3</sub>	H <sup>1)</sup>	H <sup>2)</sup>	H <sub>3</sub>	N <sub>8</sub> <sup>1)3)</sup>	N <sub>8</sub> <sup>2)3)</sup>	N <sub>9</sub>	S <sub>8</sub>	
25	R1820 241 20	45.4	49.4	12	36	40	28.9	14	18	6	M6	32

- 1) Dimension for Runner Block flange
- 2) Dimension for runner block, slimline
- 3) Dimension with regard to the screw-on surface of the Runner Block

# Lube fittings

## Hydraulic-type lube nipple

(Lube nipple included in the scope of delivery)

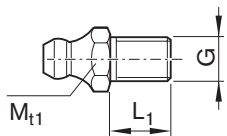

Material numbers	Dimensions (mm)		Tightening torque (Nm)	Mass (g)
	G	L <sub>1</sub>	M <sub>t1</sub>	
R3417 008 02	M6	8	1.8	2.6
R3417 014 02	M8x1	10	1.8	4.5

## Hydraulic-type lube nipple 45°

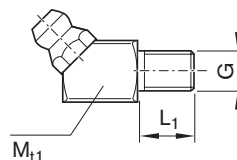

Material numbers	Dimensions (mm)		Tightening torque (Nm)	Mass (g)
	G	L <sub>1</sub>	M <sub>t1</sub>	
R3417 007 02	M6	8	1.8	7.4

## Hydraulic-type lube nipple 30°

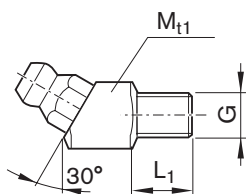

Material numbers	Dimensions (mm)		Tightening torque (Nm)	Mass (g)
	G	L <sub>1</sub>	M <sub>t1</sub>	
R3417 023 02	M6	8	1.8	7.4

## Reducer M6

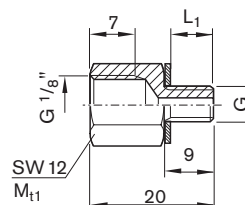

Material numbers	Dimensions (mm)		Tightening torque (Nm)	Mass (g)
	G	L <sub>1</sub>	M <sub>t1</sub>	
R3455 032 04	M6	8	1.8	1.5

## Reducer M8 x 1

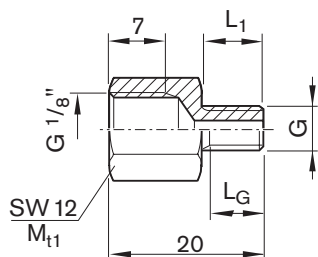

Material numbers	Dimensions (mm)			Tightening torque (Nm)	Mass (g)
	G	L <sub>1</sub>	L <sub>G</sub>	M <sub>t1</sub>	
R3455 030 51	M8x1	8	6.5	1.8	8.6

## Extensions

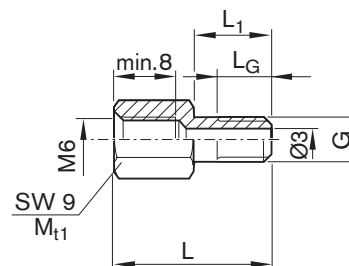

Material numbers	Dimensions (mm)				Tightening torque (Nm)	Mass (g)
	G	L	L <sub>1</sub>	L <sub>G</sub>	M <sub>t1</sub>	
R3455 033 04 <sup>1)</sup>	M6	19.5	9.0	7.5	1.8	5.0
R3455 034 04 <sup>2)</sup>	M6	20.5	10.0	8.0	1.8	5.5
R3455 035 04 <sup>3)</sup>	M6	24.5	14.0	8.0	1.8	5.5
R3455 036 04 <sup>4)</sup>	M6	25.5	15.0	8.0	1.8	6.0
R3455 037 04 <sup>5)</sup>	M6	26.5	16.0	8.0	1.8	6.0

- 1) With cover plate wiper, sizes 25 to 35
- 2) With cover plate wiper, sizes 45 to 65
- 3) with FKM seal, sizes 25 to 65
- 4) with Set FKM, sizes 25 to 35
- 5) With Set FKM, sizes 45 to 65

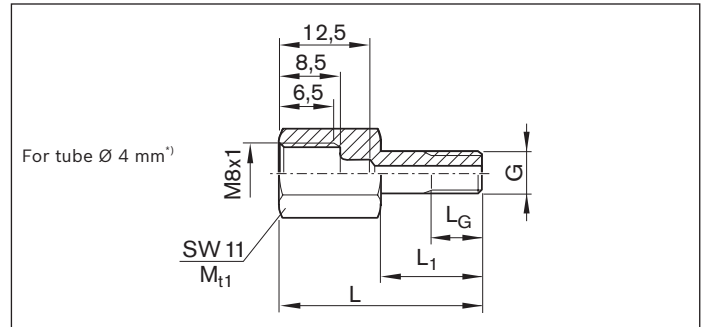
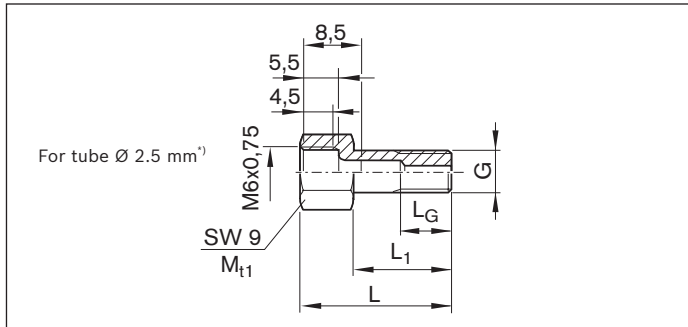
**Connectors**

Material numbers	Dimensions (mm)				Tightening torque (Nm)		Mass (g)
	G	L	L <sub>1</sub>	L <sub>G</sub>	M <sub>t1</sub>		
R3455 030 38 <sup>1)</sup>	M6	15.5	8.0	6.5	1.8		4.0
R3455 038 04 <sup>2)</sup>	M6	16.5	9.0	7.5	1.8		5.0
R3455 039 04 <sup>3)</sup>	M6	17.5	10.0	8.0	1.8		5.5
R3455 040 04 <sup>4)</sup>	M6	21.5	14.0	8.0	1.8		5.5
R3455 041 04 <sup>5)</sup>	M6	22.5	15.0	8.0	1.8		6.0
R3455 042 04 <sup>6)</sup>	M6	23.5	16.0	8.0	1.8		6.0

Material numbers	Dimensions (mm)				Tightening torque (Nm)		Mass (g)
	G	L	L <sub>1</sub>	L <sub>G</sub>	M <sub>t1</sub>		
R3455 030 37 <sup>1)</sup>	M6	22.0	8.0	6.5	1.8		9.0
R3455 043 04 <sup>2)</sup>	M6	23.0	9.0	7.5	1.8		9.5
R3455 044 04 <sup>3)</sup>	M6	24.0	10.0	8.0	1.8		10.0
R3455 045 04 <sup>4)</sup>	M6	28.0	14.0	8.0	1.8		10.5
R3455 046 04 <sup>5)</sup>	M6	29.0	15.0	8.0	1.8		10.5
R3455 030 52 <sup>6)</sup>	M6	30.0	16.0	8.0	1.8		11.0

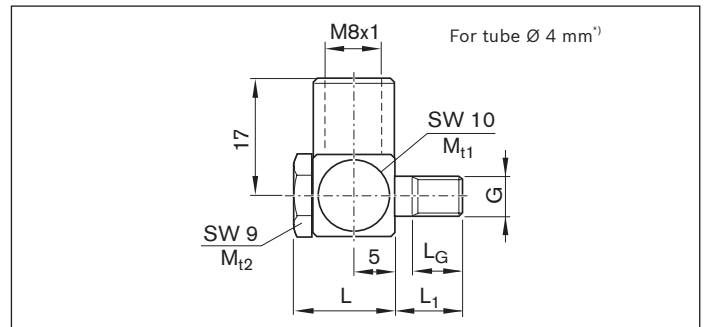
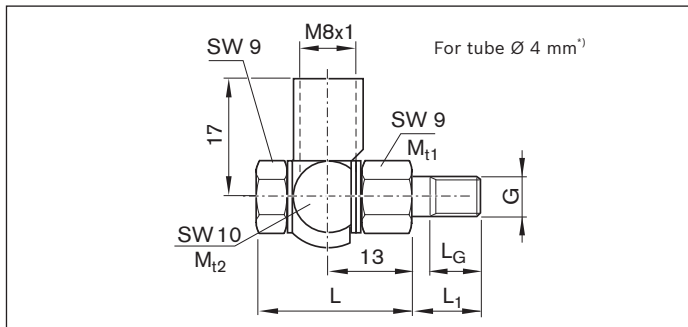
**Swivel fittings**

Material numbers	Dimensions (mm)				Tightening torque (Nm)		Mass (g)
	G	L	L <sub>1</sub>	L <sub>G</sub>	M <sub>t1</sub>	M <sub>t2</sub>	
R3417 018 09 <sup>1)</sup>	M6	22	8.0	6.5	1.8	5.0	17.0
R3417 059 09 <sup>2)</sup>	M6	22	9.0	7.5	1.8	5.0	17.0
R3417 060 09 <sup>3)</sup>	M6	22	10.0	8.0	1.8	5.0	17.5
R3417 061 09 <sup>4)</sup>	M6	22	14.0	8.0	1.8	5.0	19.0
R3417 062 09 <sup>5)</sup>	M6	22	15.0	8.0	1.8	5.0	19.5
R3417 063 09 <sup>6)</sup>	M6	22	16.0	8.0	1.8	5.0	20.0

Material numbers	Dimensions (mm)				Tightening torque (Nm)		Mass (g)
	G	L	L <sub>1</sub>	L <sub>G</sub>	M <sub>t1</sub>	M <sub>t2</sub>	
R3417 047 09 <sup>1)</sup>	M6	12	8.0	8.0	1.8	5.0	10.0
R3417 064 09 <sup>2)</sup>	M6	12	9.0	7.5	1.8	5.0	10.0
R3417 065 09 <sup>3)</sup>	M6	12	10.0	8.0	1.8	5.0	10.5
R3417 066 09 <sup>4)</sup>	M6	12	14.0	8.0	1.8	5.0	10.5
R3417 067 09 <sup>5)</sup>	M6	12	15.0	8.0	1.8	5.0	11.0
R3417 068 09 <sup>6)</sup>	M6	12	18.0	8.0	1.8	5.0	12.0

- 1) Side and end-face lube connection (without connection elements).
- 2) With cover plate wiper, sizes 25 to 35
- 3) With cover plate wiper, sizes 45 to 65
- 4) With FKM, sizes 25 to 65
- 5) With Set FKM, sizes 25 to 35
- 6) With Set FKM, sizes 45 to 65

<sup>\*)</sup> For connection according to DIN 3854 and DIN 3862 (solderless pipe fittings)

**Note on swivel fittings**

M<sub>t2</sub> is required for sealing the swivel arm above the copper washers. Since M<sub>t2</sub> is greater than M<sub>t1</sub>, it is to be held against when mounting the swivel arm. Otherwise, the lube connection would be screwed into the Runner Block with an excessive torque.

# Lube fittings

## Push-in fittings for tubes

### Tube materials

- ▶ Copper
- ▶ Brass
- ▶ PU
- ▶ Nylon

## Straight connectors

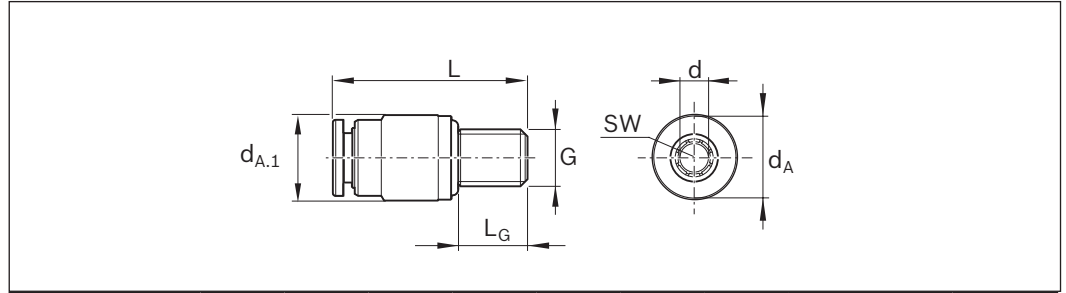

Material numbers	Dimensions (mm)							Tightening torque (Nm) $M_{t1}$	Mass (g)
	$d_A$	$d_{A.1}$	$d^{1)}$	G	L	$L_G$	SW <sup>2)</sup>		
<b>R3417 075 09</b>	9.0	9.0	4	M6	24.5	8	2.5	1.8	4.9
<b>R3417 076 09</b>	11.0	11.0	6	M6	26.0	8	2.5	1.8	6.2

- 1) Tube diameter
- 2) Internal width across flats

## Elbow plug-in connections rotatable<sup>1)</sup>

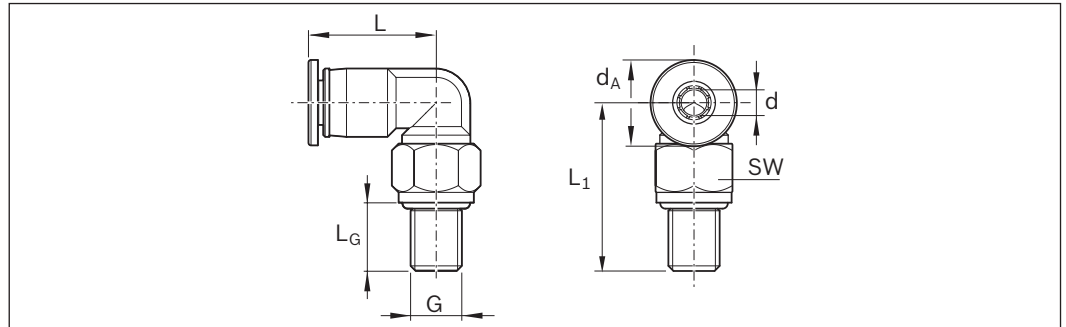

Material numbers	Dimensions (mm)							Tightening torque (Nm) $M_{t1}$	Mass (g)
	$d_A$	$d^{2)}$	G	L	$L_1$	$L_G$	SW <sup>3)</sup>		
<b>R3417 078 09</b>	9.0	4	M6	18.1	18.1	8	9	1.8	10.8
<b>R3417 079 09</b>	11.0	6	M6	20.8	18.1	8	9	1.8	12.9

- 1) Max. lubrication pressure: 30 bar (when using a grease gun, pump slowly)
- 2) Tube diameter
- 3) External width across flats

## O-rings

Material numbers	$d_1 \times d_2$ mm	Mass g
<b>R3411 108 01</b>	5 x 1.5	0.04
<b>R3411 122 01</b>	7 x 1.5	0.06
<b>R3411 018 01</b>	12 x 1.5	0.09
<b>R3411 145 01</b>	15 x 2.5	0.34

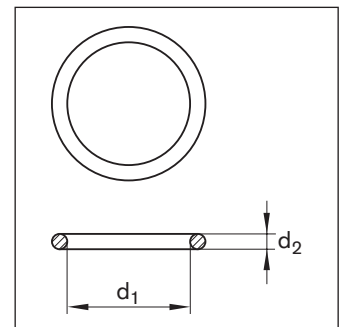

# Overview of Accessories for heavy-duty Roller runner blocks

## Cover plate wiper

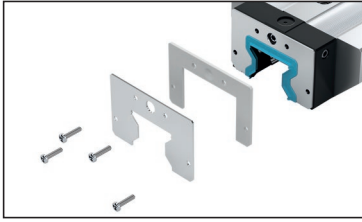

## FKM seal

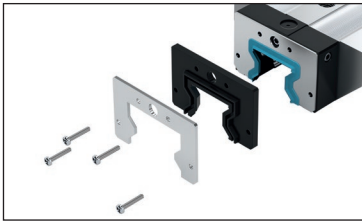

## FKM seal set

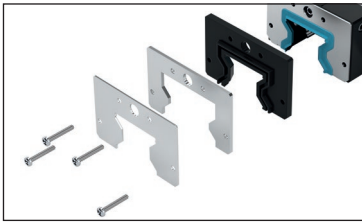

# Cover plate wiper R18.0 ... 40

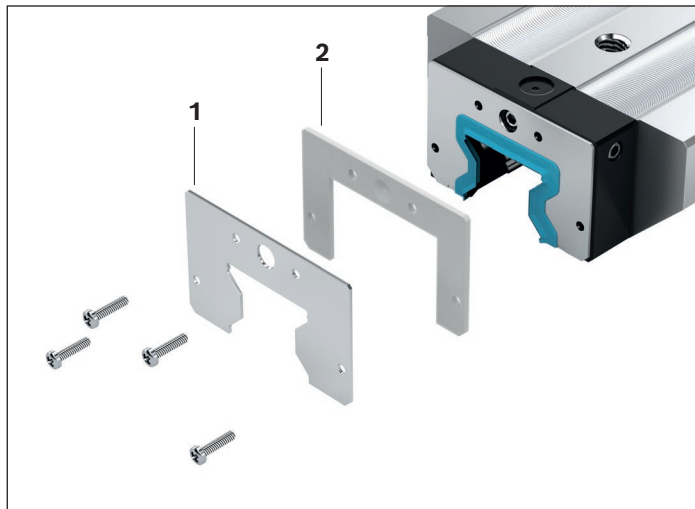

For mounting on the roller runner block for roller guide rails with/without cover strip

- 1** Cover plate wiper
  - Material: Rust-free spring steel in as per DIN EN 10088; version: blank
- 2** Spacer plate; material: aluminum

Instruction for mounting:

The spacer plate and the fixing screws are included (without lube nipple). When mounting, ensure an even gap between the Guide Rail and the cover plate wiper.

With end-face lube connection:

Drill through bore hole  $S_2$  in the spacer plate.

Use special lube nipple or adapter (see "Accessories").

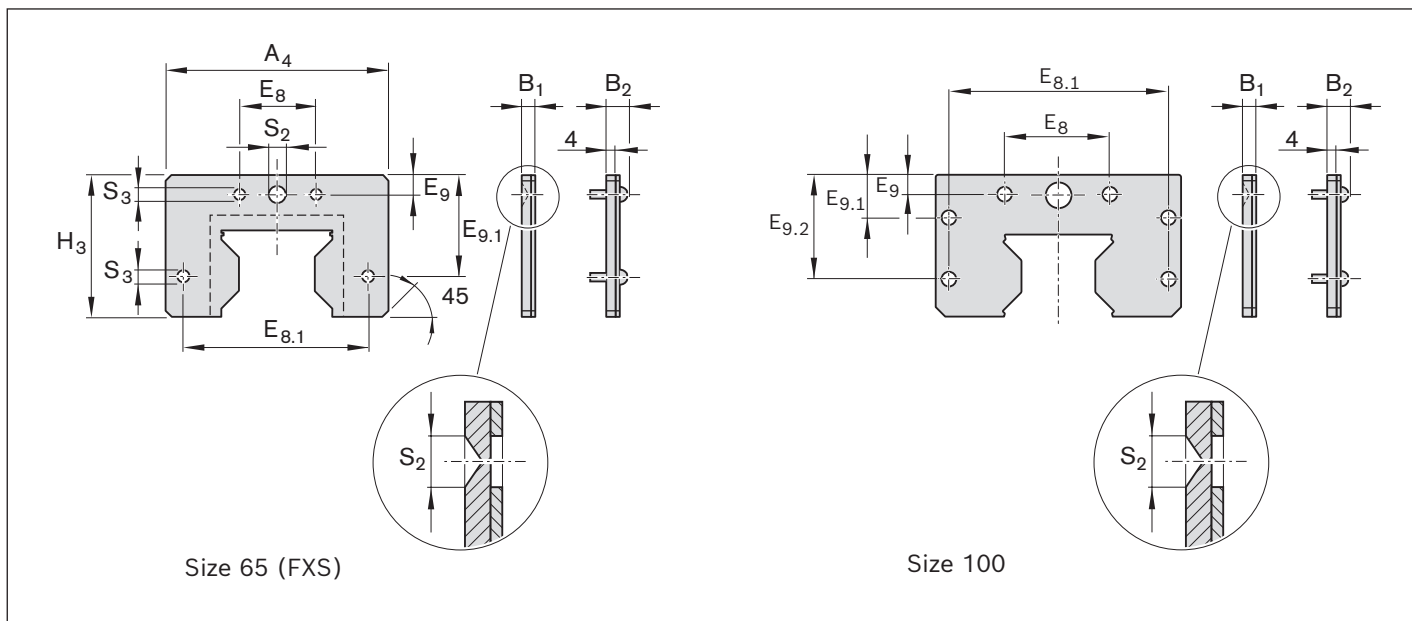

## Material numbers and dimensions

Size	Material number	Dimensions (mm)											Mass (g)
		$A_4$	$H_3$	$B_1$	$B_2$	$E_8$	$E_{8.1}$	$E_9$	$E_{9.1}$	$E_{9.2}$	$S_2$	$S_3$	
<b>65 (FXS)</b>	R1820 610 40	119.0	74.5	6.0	8.75	35	106.0	8.3	54.0	–	Ø 7	Ø 5	170
<b>100<sup>1)</sup></b>	R1810 291 40	180.5	103.5	2.5	6.50	64	162.6	8.0	28.4	69.0	Ø 9	Ø 6	300

1) Generation 1

## FKM seal R1810 ... 9.

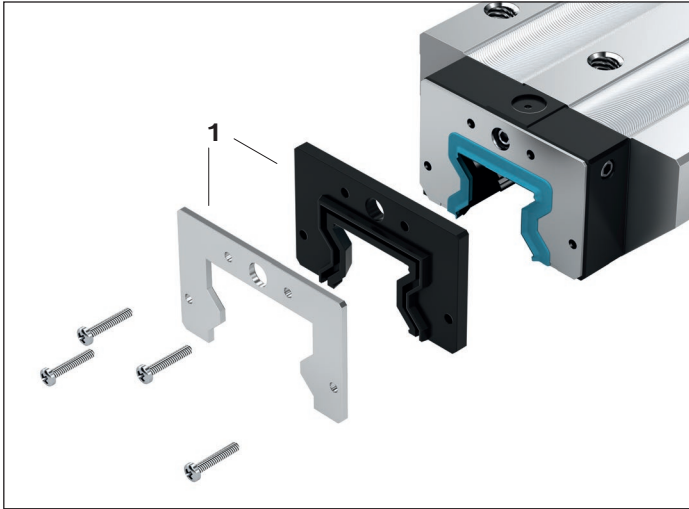

For mounting at the roller runner block

**1** Two-piece FKM seal

- Material: Stainless steel plus FKM seal

Special feature: Simple mounting and dismantling at fastened roller guide rail. Observe the mounting instructions.

Instruction for mounting:

The fastening screws are included.

Max. tightening torque 0.4 Nm

With end-face lube connection: Use special lube nipple or adapter (see "Accessories").

Combination with additional cover plate wiper possible. Use the FKM seal set and cover plate wiper (see following page).

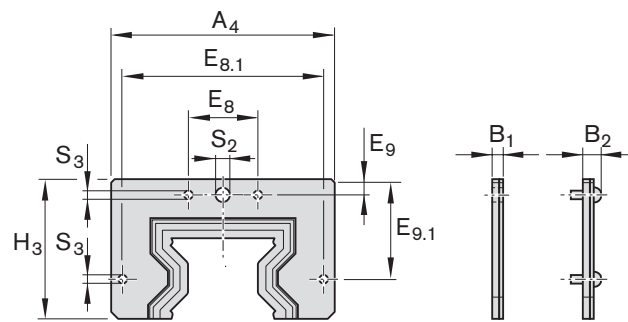

Size 65 (FXS)

### Material numbers and dimensions

Size	Material number	Dimensions (mm)										Mass (g)
		A <sub>4</sub>	H <sub>3</sub>	B <sub>1</sub>	B <sub>2</sub>	E <sub>8</sub>	E <sub>8.1</sub>	E <sub>9</sub>	E <sub>9.1</sub>	S <sub>2</sub>	S <sub>3</sub>	
<b>65 (FXS)</b>	R1810 600 90	119	75	6.5	9.25	35	106	8.55	54.25	∅ 7	∅ 5	160

# FKM seal set

## R1810 605 70

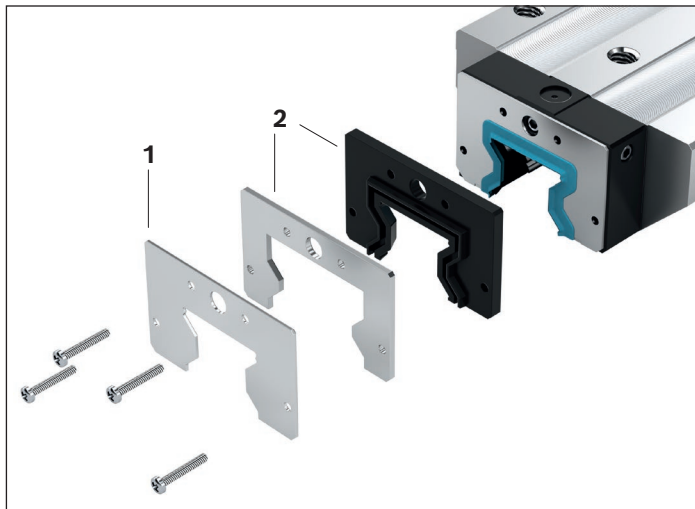

For mounting at the roller runner block  
FKM seal and cover plate wiper:

- 1 Cover plate wiper
- 2 Two-piece FKM seal

Instruction for mounting:

The fastening screws are included.

Max. tightening torque 0.4 Nm

With end-face lube connection:

Use special lube nipple or adapter (see "Accessories").

Observe the mounting instructions.

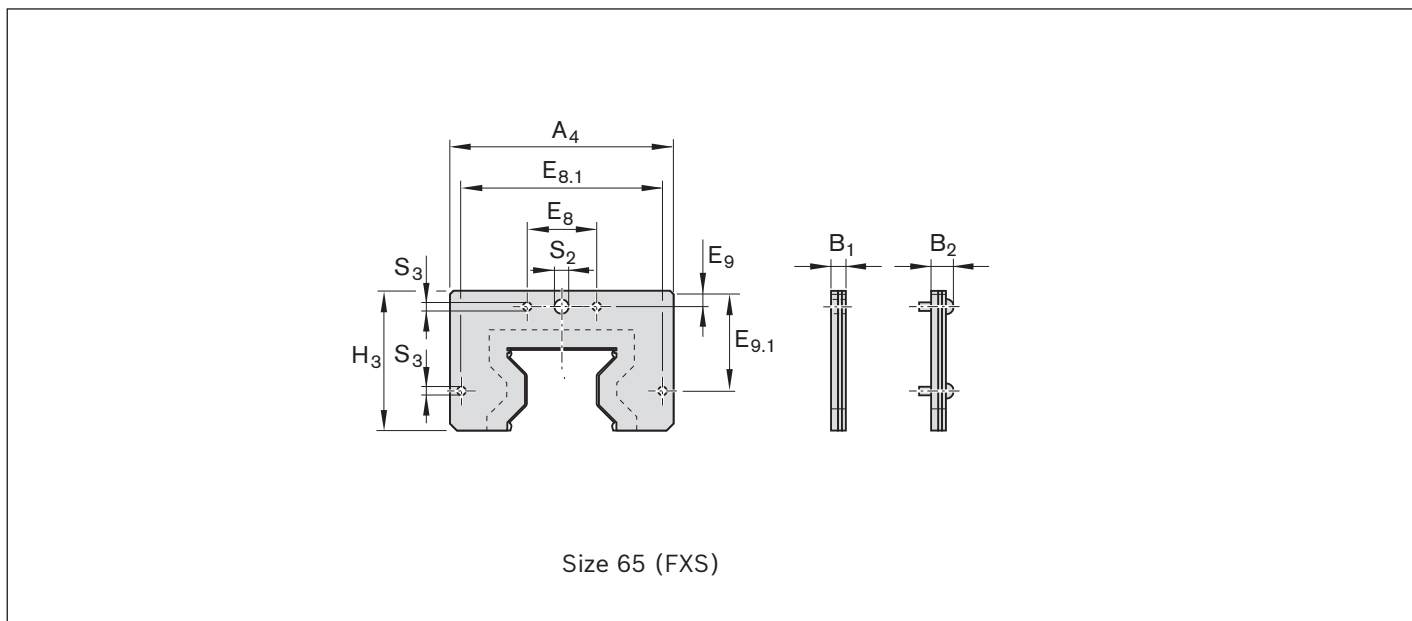

### Material numbers and dimensions

Size	Material number	Dimensions (mm)										Mass (g)
		A <sub>4</sub>	H <sub>3</sub>	B <sub>1</sub>	B <sub>2</sub>	E <sub>8</sub>	E <sub>8.1</sub>	E <sub>9</sub>	E <sub>9.1</sub>	S <sub>2</sub>	S <sub>3</sub>	
65 (FXS)	R1810 605 70	119	75	8.5	11.25	35	106	8.55	54.25	Ø 7	Ø 5	240

# Overview of Accessories for roller guide rails

**Mounting runner block**

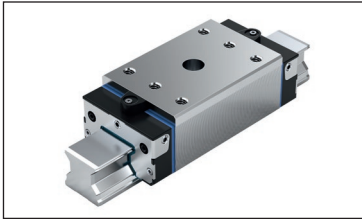

**Plastic caps**



**Cover strip**



**Steel caps**

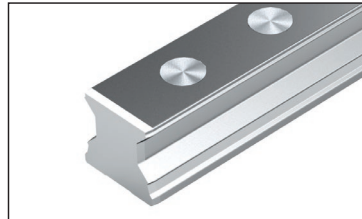

**Mounting devices for cover strip**

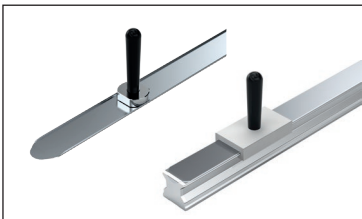

**Mounting devices for steel caps**

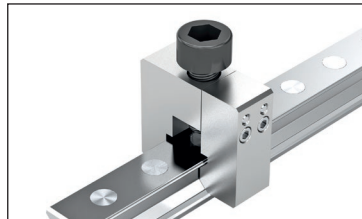

**Protective cap**



**Adjusting shafts**



**Strip clamp**

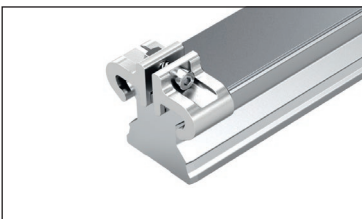

**V-guide**



**Cardboard box opener**



## Mounting runner block



### Mounting Runner Block SLH R1829 Slimline, long, high

Mounting device for parallel alignment of Standard roller guide rails

Size	Material numbers with preload class C3
25	R1829 220 90
35	R1829 320 90
45	R1829 420 90
55	R1829 520 90
65	R1829 620 90

### Mounting with mounting runner block

#### Note

Bore D is at the same time a key and a screw hole. Use the middle bore D in the mounting runner block to measure exactly in the center, then fasten the roller guide rail with the mounting runner block.

#### Aligning the rails

1. Align and mount the first roller guide rail using a graduated straightedge.
2. Set up a mounting bridge with dial gauge between the Roller runner blocks.
3. Move both roller runner blocks in parallel until bore D in the mounting runner block is positioned precisely above a fastening bore in the rail.
4. Align the roller guide rail manually until the dial gauge shows the correct dimension.
5. Then screw down the roller guide rail using the Mounting Runner Block.

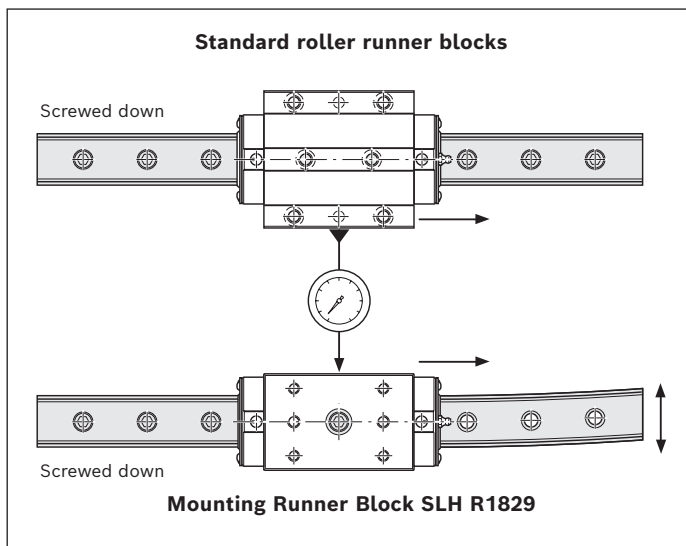

Size	Dimensions <sup>1)</sup> (mm)				Mass (kg)
	A	B <sub>1</sub>	B <sub>3</sub>	D	
25	48	81.5	115	19	0.8
35	70	103.6	145	25	1.9
45	86	134.0	183	27	4.0
55	100	162.1	216	27	6.0
65	126	194.0	264	30	11.8

1) For all other dimensions, see roller runner block SLH R1824 ... 10

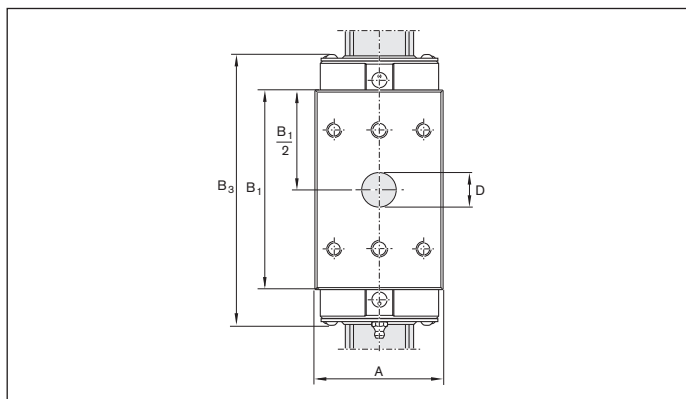

# Cover strip

## Note on cover strip

For detailed information, see "Mounting instructions for cover strip".

### Advantages

The cover strip is easy to clip on and remove.

- ▶ This considerably facilitates and speeds up the mounting process:
- ▶ Multiple mounting and dismounting possible.

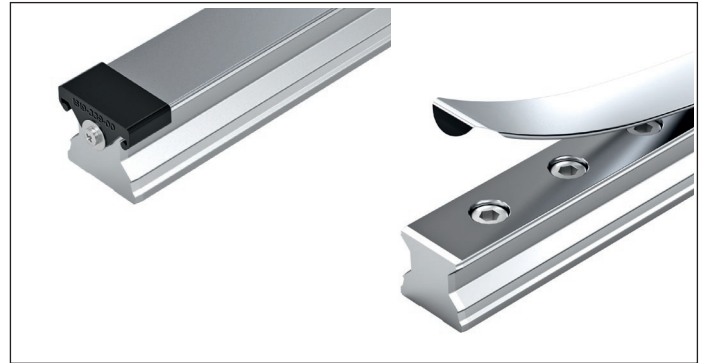

### Versions and functions

#### A Cover strip with snap fit (standard)

- ▶ The cover strip is clipped on before the roller runner block is mounted and fits tightly.

#### B Cover strip with sliding fit

- ▶ For mounting or replacing a cover strip, if the roller runner block or connection structure cannot be removed.
- ▶ A section of the snap fit cover strip is very slightly widened and can then be easily slid under the roller runner block.

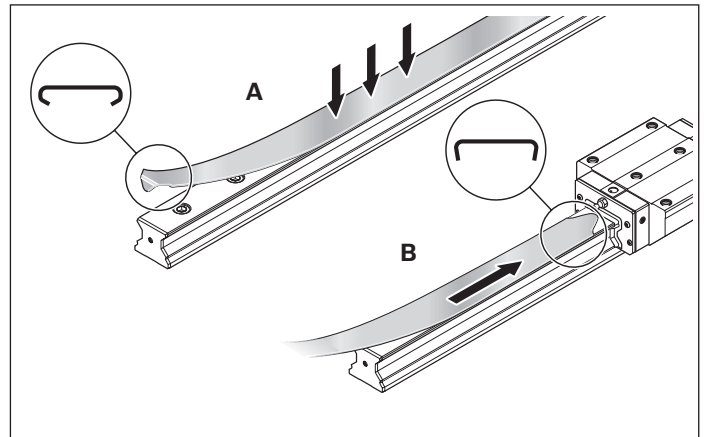

An expanding tool for cover strips can be used to create a sliding fit after installation.

In particular, the sliding length  $L_S$  can be adapted in accordance with the installation case.

Observe the detailed mounting instructions!

For material numbers, please refer to the following pages.

- ⚠ The cover strip is a precision-machined part that requires careful handling. Above all, it must not be bent.

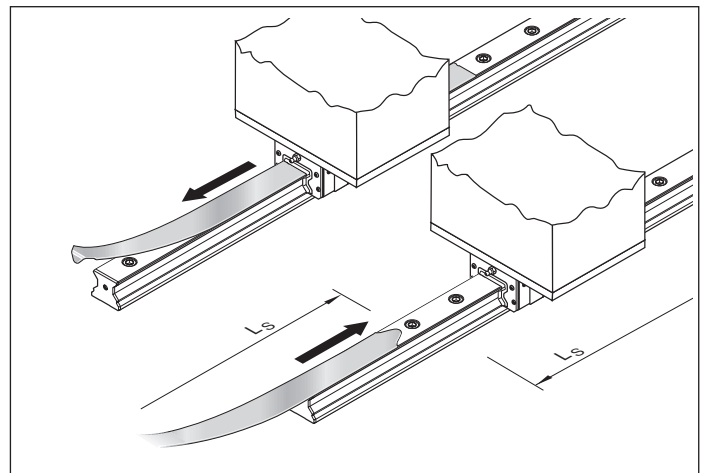

- ⚠ Do not execute stroke to the end of the rail continuously!  
The seals on the roller runner block can get damaged on the bevel of the cover strip.

- ▶ Minimum distance  $L_{min}$  from the end of the rail to be complied with.

Size	L (mm)
25	Approx. 10.0
35-65	Approx. 12.0
100	Approx. 12.0
125	Approx. 21.5

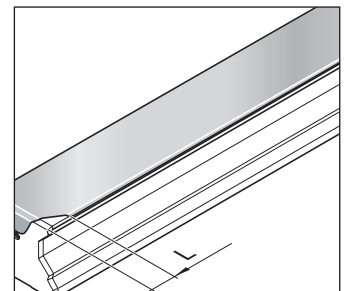

## Cover strip

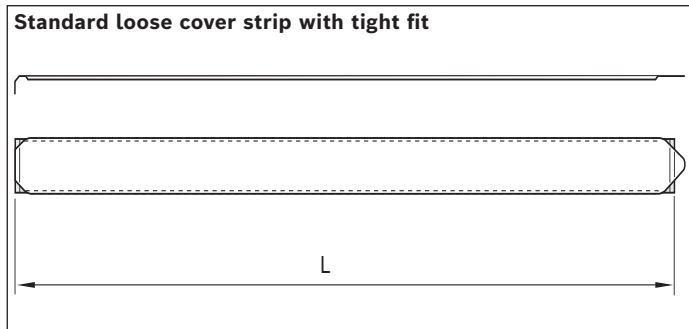

Size	Standard loose cover strip with tight fit Material number, length L (mm)	Mass (g/m)
25	R1619 230 00, ....	32
35	R1619 330 20, ....	80
45	R1619 430 20, ....	100
55	R1619 530 20, ....	120
65	R1619 630 20, ....	140
100	R1810 231 20, ....	200
125	R1810 331 20, ....	270

### Loose cover strip

**For initial installation, storage and replacement**

#### Note

A suitable cover strip with snap fit or with sliding fit is available for each roller guide rail length (see preceding page).

#### Ordering example

##### Standard loose cover strip with tight fit

- ▶ Roller guide rail size 35
- ▶ Rail length L = 2696 mm

#### Ordering data

Material number, length L (mm)

**R1619 330 20, 2696 mm**

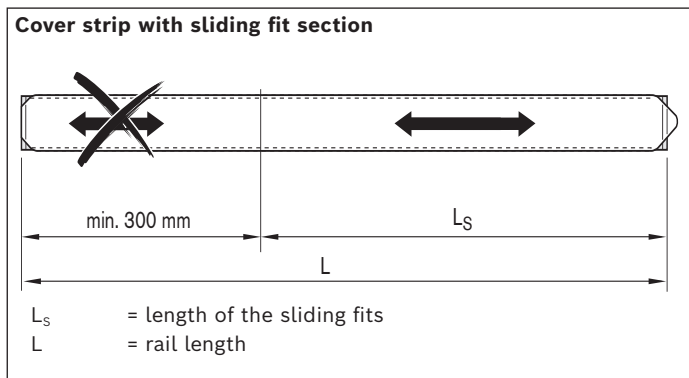

Size	Cover strip with sliding fit section Material number, length L (mm)	Mass (g/m)
25	R1619 230 10, ....	25
35	R1619 330 30, ....	80
45	R1619 430 30, ....	100
55	R1619 530 30, ....	120
65	R1619 630 30, ....	140
100	R1810 231 30, ....	200
125	R1810 331 30, ....	270

#### Ordering example

##### Cover strip with sliding fit section

- ▶ Roller guide rail size 35
- ▶ Rail length L = 2696 mm
- ▶ Length of sliding fit section L<sub>s</sub> = 1200 mm

#### Ordering data

Material number, length L (mm),

Length of sliding fit L<sub>s</sub> (mm)

**R1619 330 30, 2696, 1200 mm**

For additional, detailed information the order and assembly of cover strips, see "Mounting instructions for cover strip".

## Mounting device for cover strip

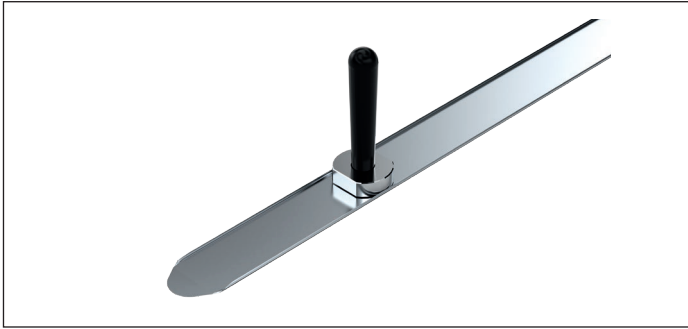

### Expanding tool

#### For creating a sliding fit in the cover strip

#### Note

For detailed information on creation and assembly of cover strips with sliding fit, see "Mounting instructions for cover strip".

Size	Material numbers	Mass (kg)
25	R1619 215 10	0.08
35	R1619 315 30	0.10
45	R1619 415 30	0.13
55	R1619 515 30	0.21
65	R1619 615 30	0.27
100	R1810 291 30	on request
125	R1810 391 30	

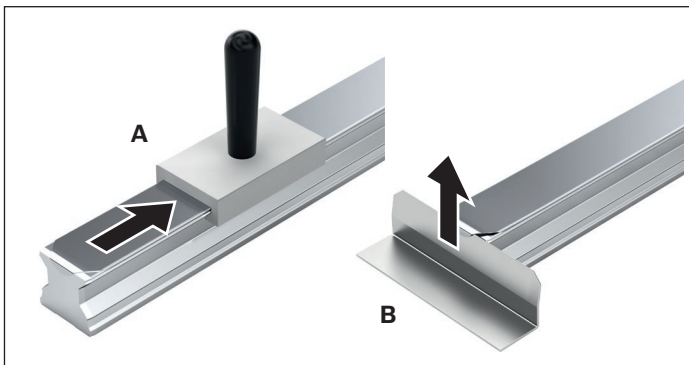

## Cover strip mounting kit

### Mounting device and lift-off plate

#### Notes

To clip on the cover strip, a mounting device (A) is available; for removal, there is a lift-off plate (B). For additional, detailed information, see "Mounting instructions for cover strip".

Size	Material numbers	Mass (kg)
25	R1619 210 70	0.17
35	R1619 310 50	0.21
45	R1619 410 50	0.20
55	R1619 510 50	0.21
65	R1619 610 50	0.28
100	R1810 291 53	on request
125	R1810 391 53	

## Retainers for cover strip

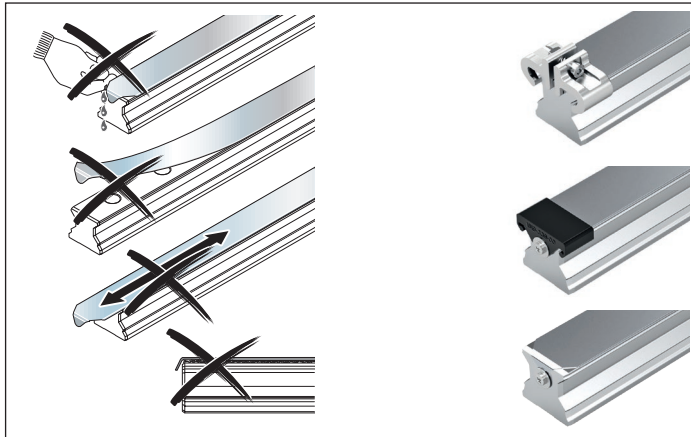

### Retainer for cover strip

Rexroth recommends securing the cover strip with:

- ▶ Protective caps
- ▶ Screws and washers
- ▶ Strip clamps (see the following page)

For additional securing options for the cover strip, see "Mounting instructions for cover strip".

### Protective caps

Size	Single cap		Bulk packaging		Set (2 per unit with screws)	
	Material numbers (without screws)	Mass (g)	Material number/piece (without screws)	Mass (kg)	Material numbers (Unit)	Mass (g)
25	R1619 239 00	1.0	R1619 239 01 / 1000	1.3	R1619 239 20	7
35	R1619 339 10	2.0	R1619 339 01 / 1000	2.5	R1619 339 30	10
45	R1619 439 00	4.0	R1619 439 01 / 700	2.6	R1619 439 20	13
55	R1619 539 00	4.0	R1619 539 01 / 500	2.1	R1619 539 20	20
65	R1619 639 00	6.0	R1619 639 01 / 300	1.7	R1619 639 20	20

### Screws and washers

Size	Screws (1200 pieces per unit)		Washers (1200 pieces per unit)	
	Material numbers (Unit)	Mass (kg)	Material numbers (Unit)	Mass (kg)
25	R3427 046 05	1.8	R3448 026 01	0.92
35	R3427 046 05	1.8	R3448 024 01	1.30
45	R3427 046 05	1.8	R3448 024 01	1.30
55	R3427 046 05	1.8	R3448 027 01	2.90
65	R3427 046 05	1.8	R3448 027 01	2.90
100	R3427 046 05	1.8	R3448 027 01	2.90
125	R3427 046 05	1.8	R3448 027 01	2.90

## Retainers for cover strip

### Strip clamps

Size	Set (2 pieces per unit)		Bulk packaging (100 pieces per unit)	
	Material numbers (Unit)	Mass (g)	Material numbers (Unit)	Mass (kg)
25	R1619 239 50	14	R1619 239 60	1.4
35	R1619 339 50	38	R1619 339 60	3.8
45	R1619 439 50	56	R1619 439 60	5.6
55	R1619 539 50	62	R1619 539 60	6.2
65	R1619 639 50	84	R1619 639 60	8.4

## Plastic caps



### Instruction for mounting

- For mounting plastic mounting hole plugs, see "Mounting instructions for Roller Rail Systems".

### Plastic caps material numbers

Size	Single plastic cap		Bulk packaging	
	Material numbers	Mass (g)	Material numbers/pieces	Mass / packaging (kg)
25	R1605 200 80	0.3	R1605 200 80 / 5000	1.2
35	R1605 300 80	0.6	R1605 300 80 / 2000	1.2
45	R1605 400 80	1.0	R1605 400 80 / 1000	1.0
55	R1605 500 80	1.7	R1605 500 80 / 500	1.7
65	R1605 600 80	2.1	-	-

## Steel caps

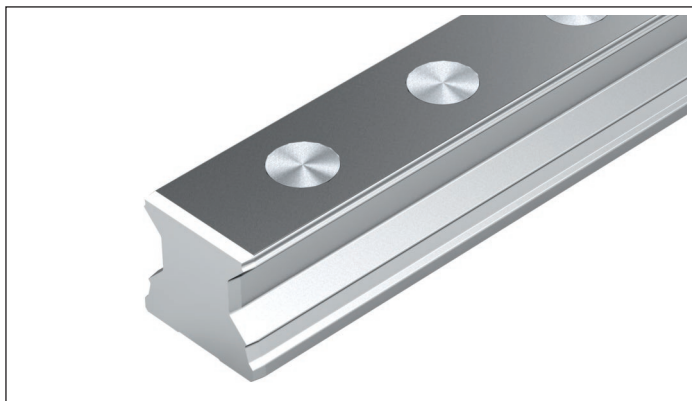

### Notes

- ▶ Steel caps are not included in the scope of delivery of the roller guide rails.
- ▶ Order the mounting tool too!
- ▶ For mounting steel mounting hole plugs, see "Mounting instructions for Roller Rail Systems".

### Material numbers of steel caps

Size	Single cap made of machining steel		Single cap Resist NR II <sup>1)</sup>	
	Material numbers	Mass (g)	Material numbers	Mass (g)
25	R1606 200 75	2	–	–
35	R1606 300 75	3	R1606 300 78	3
45	R1606 400 75	6	R1606 400 78	6
55	R1606 500 75	8	R1606 500 78	8
65	R1606 600 75	9	R1606 600 78	9
100	R1836 200 75	23	–	–

1) Made of corrosion-resistant steel 1.4305

## Mounting tool for steel caps

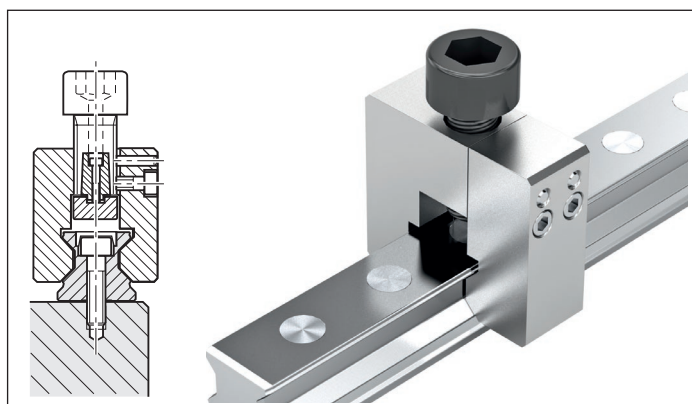

### Notes

- ▶ The two-piece mounting tool is suitable for mounting caps in built-in roller guide rails (mounting instructions enclosed).

### Material numbers for mounting tool

Size	Material numbers	Mass (kg)
25 <sup>2)</sup>	R1619 210 20	0.37
35	R1619 310 30	0.57
45	R1619 410 30	0.85
55	R1619 510 30	1.50
65	R1619 610 30	1.85
100	R1810 251 30	2.80

2) Can only be delivered as one part

## Adjusting shafts



### Adjusting shafts

#### Mounting device for multi-piece roller guide rails

#### Notes

Adjusting shafts are particularly helpful when there is no reference edge.

Observe "Mounting instructions for Roller Rail Systems".

#### Order note

For mounting, always order **two** adjustment shafts.

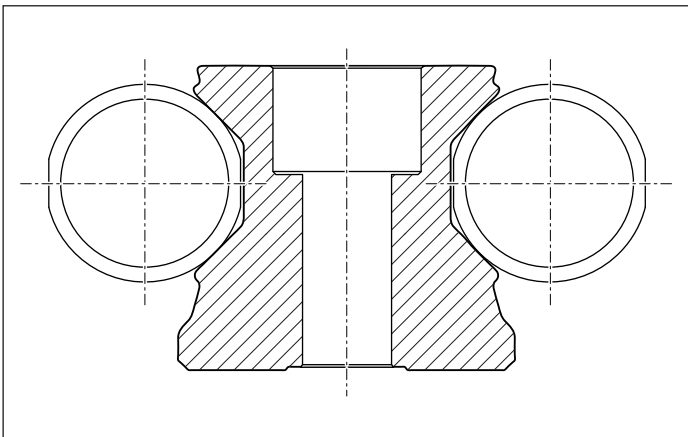

Alignment of the flattened adjustment shafts

Size	Material numbers Adjustment shaft (single)	Dimensions (mm)		Mass (kg)
		Ø shaft	Length	
35	R1810 390 01	20	160	0.4
45	R1810 490 01	25	200	0.8
55	R1810 590 01	30	250	1.4
65	R1810 690 01	35	300	2.3
100	R1810 291 01	75	400	13.9
125	R1810 391 01	80	600	23.7

## V-guide

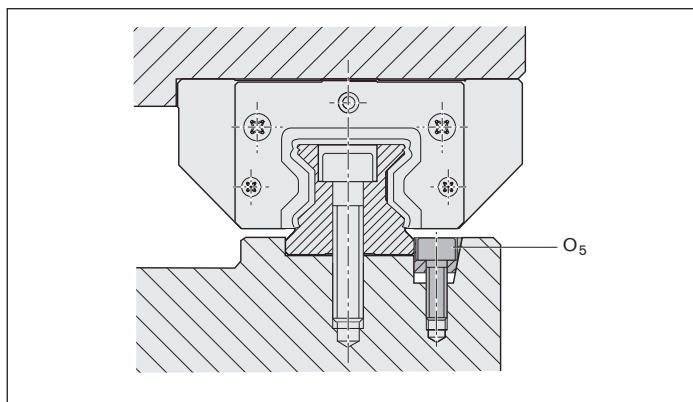

### V-guide

#### Mounting device for lateral retention of roller guide rail

- ▶ Material: Steel
- ▶ Version: black finished

Observe "Mounting instructions for Roller Rail Systems".

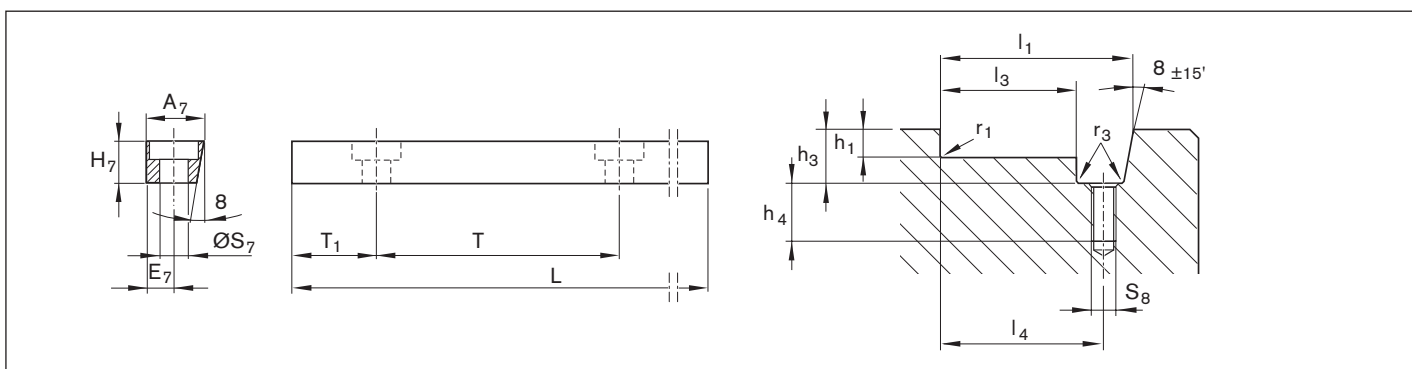

### V-guide

Size	Material numbers	Dimensions (mm)								Mass (kg)
		A <sub>7</sub>	E <sub>7</sub>	H <sub>7</sub>	L	O <sub>5</sub> <sup>1)</sup>	S <sub>7</sub>	T	T <sub>1</sub>	
25/35	R1619 200 01	12.0	6	10	957	M5x20	6.0	60	28.5	0.8
45/55/65	R1619 400 01	19.0	9	16	942	M8x25	9.0	105	51.0	2.0
100 <sup>2)</sup>	R1810 291 02	34.0	16	23	938	M12x35	13.5	105	49	5.3
125	R1810 391 02	47.5	23	30	954	M16x45	17.5	120	57.0	9.5

1) Screw O<sub>5</sub> according to DIN 6912

2) Size 100 upon request

### V-guide slot

Size	Dimensions (mm)								
	h <sub>1-0.2</sub>	h <sub>3</sub> <sup>+1</sup>	h <sub>4</sub> <sup>+2</sup>	l <sub>1</sub> <sup>±0.05</sup>	l <sub>3</sub> <sup>-0.1</sup>	l <sub>4</sub> <sup>±0.1</sup>	r <sub>1 max</sub>	r <sub>3 max</sub>	S <sub>8</sub>
25	4.5	12.5	15	35.1	22.9	29	0.8	0.5	M5
35	5.0	12.5	15	46.1	33.9	40	0.8	0.5	M5
45	7.0	19.0	16	64.1	44.9	54	0.8	0.5	M8
55	9.0	19.0	16	72.1	52.9	62	1.2	0.5	M8
65	9.0	19.0	16	82.1	62.9	72	1.2	0.5	M8
100	12.0	26.0	20	134.0	99.9	116	1.8	1.0	M12
125	20.0	34.0	29	172.6	124.9	148	1.8	1.0	M16

# Front seal

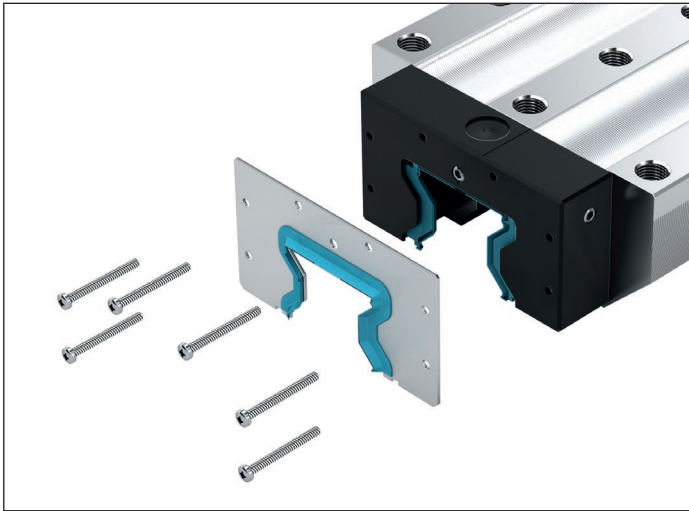

## Front seal

### Already integrated in RSHP (replacement only for 1st generation Roller runner blocks)

- ▶ Material: Corrosion-resistant spring steel according to DIN EN 10088 with plastic seal
- ▶ Version: bright

### Instruction for mounting

The fastening screws are included.

- ▶ Dispose of old screws.

For detailed information on assembly, see "Mounting instructions for the Roller Rail Systems".

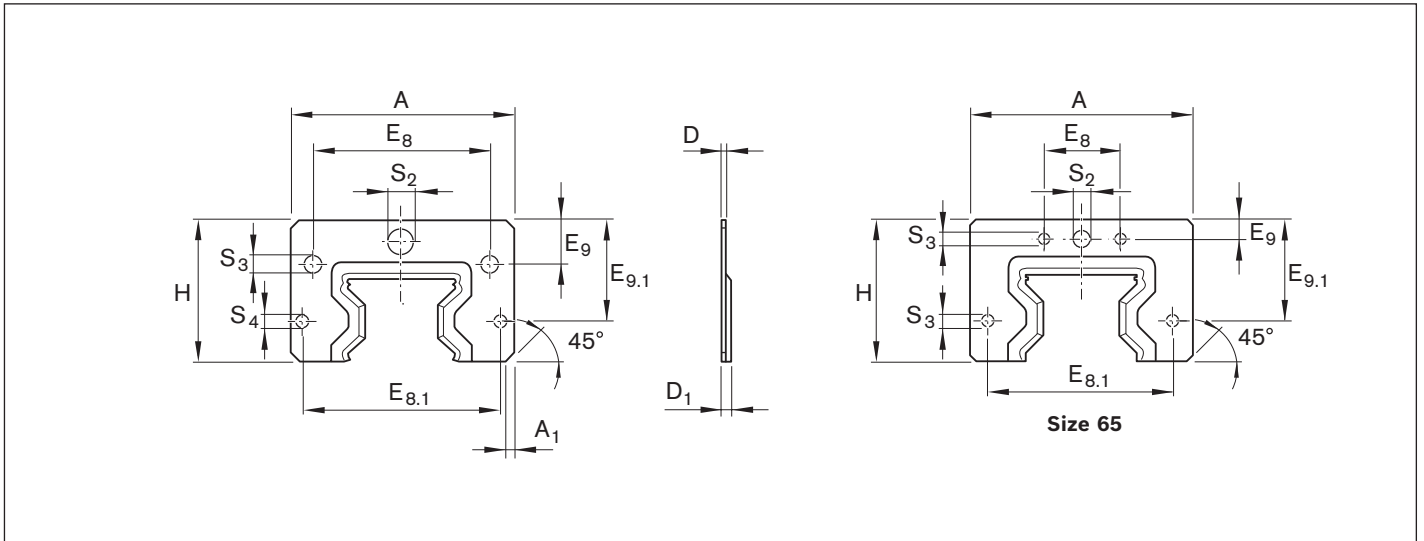

Size	Material numbers Set	Dimensions (mm)											Mass (g)	
		A	A <sub>1</sub>	D	D <sub>1</sub>	E <sub>8</sub>	E <sub>8.1</sub>	E <sub>9</sub>	E <sub>9.1</sub>	H	S <sub>2</sub>	S <sub>3</sub>		S <sub>4</sub>
<b>65 (FXS)</b>	R1810 610 00	119.0	3	2.0	5.0	35	106.0	8.3	54	74.5	7	5.0	5.0	108
<b>100</b>	R1810 211 00	181.0	2	2.5	5.5	130	162.6	28.4	61	104.0	9	6.0	6.0	280
<b>125</b>	R1810 311 00	230.0	5	3.0	6.0	205	205.0	38.0	90	133.0	9	6.5	6.5	530

## End cap with front seal set

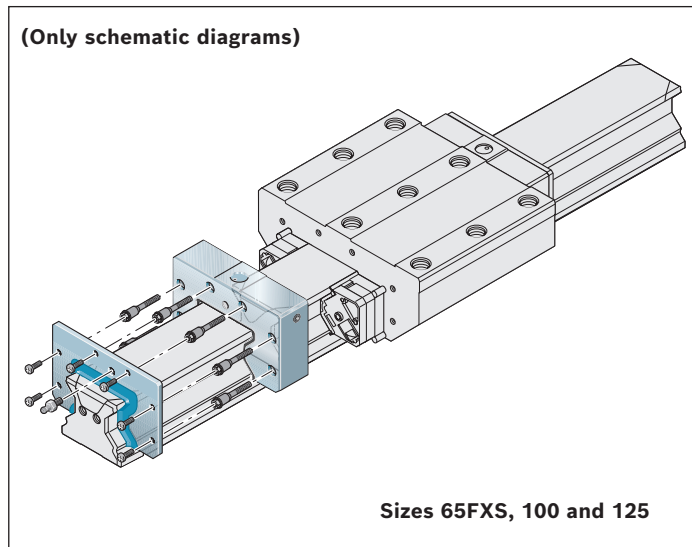

### Set for heavy-duty roller runner blocks

For replacement when servicing Roller runner blocks

#### Notes

The fastening screws are included.

- ▶ Dispose of old screws.

For more information, see "Mounting instructions for Roller Rail Systems".

Size	Material numbers for set of end caps with front seal, suitable for Heavy-duty Roller runner blocks	Set mass with end cap	
		Plastic (kg)	Aluminum (kg)
65 (FXS)	R1810 690 10	0.26	-
100	R1810 291 10	0.61	-
125	R1810 391 60	-	2.30

## Cardboard box opener



- ▶ Tool for opening the guide rails packaging
- ▶ Prevents risk of injury

#### Ordering data

Material number R320105175

# Transport lock

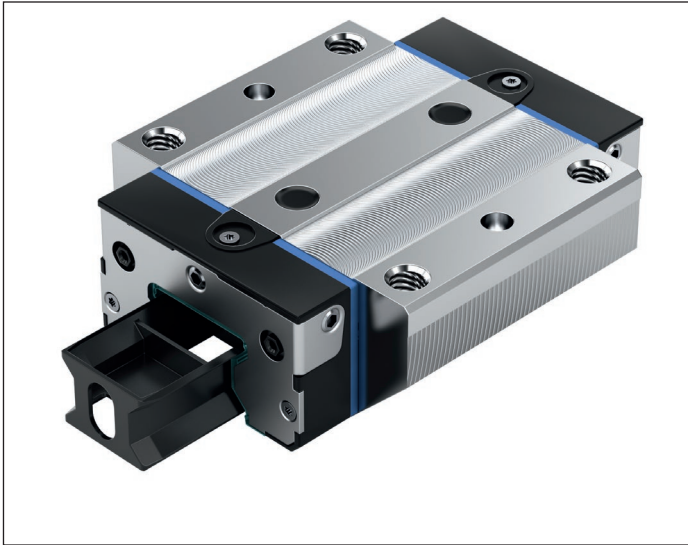

## Transport lock for roller runner block

For transporting and as a mounting device

► Material: Plastic

Size	Normal		Long	
	Material numbers	Mass (g)	Material numbers	Mass (g)
25	R1851 207 89	3.8	R1853 207 89	4.2
35	R1851 307 89	8.7	R1853 307 89	10.2
45	R1651 402 89	17.2	R1653 402 89	20.5
55	R1653 502 89	32.8	R1653 502 89	32.8
65	R1653 602 89	40.7	R1653 602 89	40.7
65 (FXS)	–	–	R1854 600 89	68.0
100	R1861 200 91	154.0	R1863 200 91	197.0
125	R1861 300 81	1888.0	R1863 300 81	2600.0

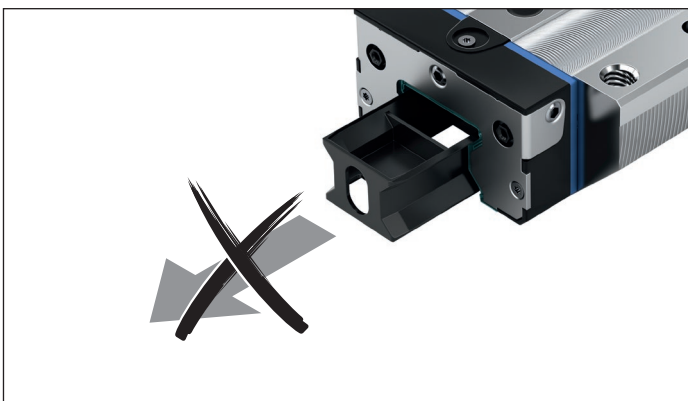







### Notes

The roller runner block is slid from the transport lock onto the rail.

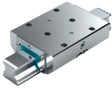

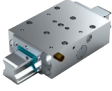









See the chapter "Instructions for mounting".

⚠ The transport lock must remain in the roller runner block until it slides onto the roller guide rail! Otherwise, the rollers may get lost!

# Clamping and braking units, product overview

Clamping and braking units			Page	Holding force <sup>1)</sup> (N)	Size						
					25	35	45	55	65	100	125
<b>Hydraulic</b>		KBH R1810 ... 21	134	7400 – 22700	–	–	●	●	●	–	–
		KWH R1810 ... 22	138	2200 – 46000	●	●	●	●	●	●	●
<b>Pneumatic</b>		MBPS R1810 ... 31	144	1300 – 4700	●	●	●	●	–	–	–
		UBPS R1810 ... 51	146	1500 – 7700	●	●	●	●	–	–	–
		MK R1810 ..2 60	150	1200 – 2250	●	●	●	●	●	–	–
		MKS R1810 ..0 60	152	750 – 1450	●	●	●	●	●	–	–
<b>Manual</b>		HK R1619 ... 82	156	1200 – 2000	●	●	●	●	●	–	–

- 1) The inspection is done in a mounted state with a lubricated layer (ISO-VG 68).
- 2) The B10d-value specifies the number of switching cycles until 10% of components fail dangerously.
- 3) Normally open / opened without pressurization
- 4) Normally closed / closed without pressurization
- 5) Bistable / stays in the current position

Technical features												
												
When de-energized	Spring-loaded accumulator	CE-marking	PLUS connection	Wiper kit available	Slimline built	Increased positioning accuracy	Release pressure (bar)	Tightening torque (Nm)	Gripper operating pressure (bar)	Clamping cycles (B10d value <sup>2)</sup> )	Braking cycles	
NO <sup>3)</sup>	-	-	-	•	-	•	-	-	100 – 150	10 million	2000	
NO <sup>3)</sup>	-	-	-	•	-	•	-	-	100 – 150	10 million	-	
NC <sup>4)</sup>	•	•	-	-	-	-	4.5	-	6	5 million	2000	
NC <sup>4)</sup>	•	•	•	•	-	•	5.5	-	6	5 million	2000	
NO <sup>3)</sup>	-	-	-	-	-	-	-	-	6	5 million	-	
NC <sup>4)</sup>	•	•	•	-	-	-	5.5	-	6	5 million	-	
N <sup>5)</sup>	-	-	-	-	-	-	-	0.07 – 2.5	-	50000	-	

# Product description hydraulic clamping and braking units

## Application areas

### Clamping

- ▶ During assembly work and standstill of the machine with energy with KBH
- ▶ Of heavy handling systems
- ▶ Clamping of machine tables from heavily machined machining centers

### Brakes

- ▶ Support as brake for linear motors
- ▶ Of heavy handling systems

## Characteristic features

- ▶ Very high axial holding forces
- ▶ Dynamic and static stabilization in the axial direction
- ▶ Heavy-duty brake

⚠ Observe the safety instructions on clamping and braking units.

## Further highlights

- ▶ Up to 1 million clamping cycles
- ▶ Up to 2,000 emergency braking operations
- ▶ Threaded on both sides for the hydraulic connection
- ▶ Solid, rigid steel housing, chemically nickel-plated
- ▶ High positioning accuracy
- ▶ Release pressure 150 bar
- ▶ Integrated all-round sealing
- ▶ Special pressure diaphragm technology for maximum functional reliability without pressure losses or leakage
- ▶ Brake shoes with integrated positive-locking, large-surface contact profiles for maximum axial rigidity
- ▶ Super heavy-duty model

## Special features of hydraulic clamping and braking units (KBH):

- ▶ Low displacement
- ▶ Compact version, compatible with DIN 645
- ▶ 10 million clamping cycles (B10d value)

## Functional principle

### Hydraulic pressure: 50 - 150 bar

#### Clamps and brakes with compression

The large-scale clamping profiles are pressed directly through the hydraulic oil via a piston principle to the flanks of the roller guide rail.

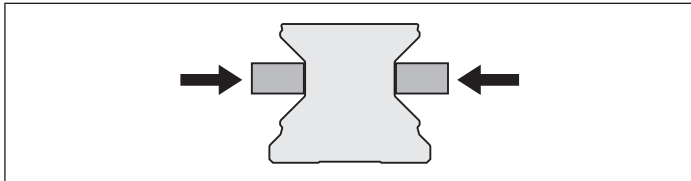

### Hydraulic pressure: 0 bar

#### Decompression with spring force

A preloaded return spring allows for short decompression cycles.

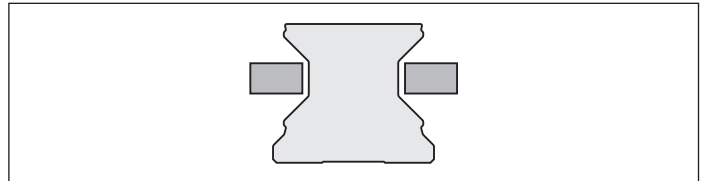

### KBH, FLS

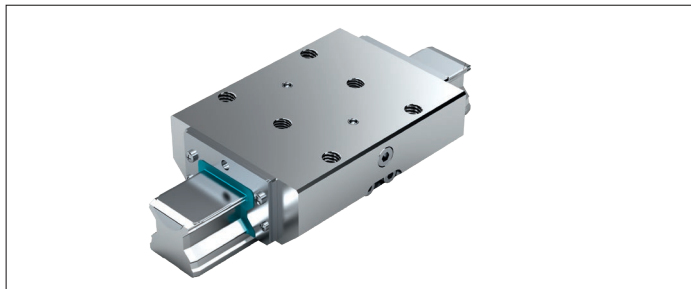

### KBH, SLH

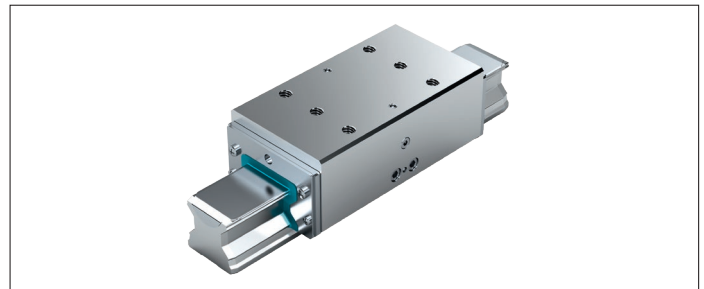

## **Additional information**

### **Hydraulic connections**

The hydraulic clamping units are pre-filled with HLP 46 at the factory. The hydraulic connection is attached on two sides. One connection is suitable for pressurization. Take care when venting fixed and flexible hydraulic lines because air ports can damage sealing elements.

### **Connection structure, mounting the clamping units**

To prevent detrimental effects, e.g. permanent grinding on the linear guide, the connection structure must be rigid and in accordance with its load and requirements. If the clamping units tilt, this can result in contact, wear and therefore damage to the linear guide.

The setting at the factory is adapted for the linear guide and may not be altered when mounting. It is imperative to observe the mounting instructions for the clamping and braking units and the linear guides.

Some spring-loaded accumulators are equipped with a transport lock between the contact profiles.

This must be removed when mounting by pressurizing the unit. When the pressure is removed, the transport lock or the associated linear guide must always lie between the contact profiles.

The clamping units do not have any guiding function. Therefore, it is not possible to replace a roller runner block with a clamping unit. The ideal position of the clamping unit lies between two roller runner blocks.

When using several clamping units, these should be distributed evenly on both roller guide rails in order to attain a maximum rigidity of the overall construction.

### **Lubrication**

When using the prescribed pressurizing medium, lubrication is not required.

### **Surface protection**

All housings of the clamping units are chemically nickel-plated and therefore have limited rust protection.

Aluminum subsections are chemically nickel-plated or hard-coated according to their requirement.

### **B10d value**

The B10d-value specifies the number of switching cycles until 10% of components fail dangerously.

# Hydraulic clamping and braking units KBH<sup>1)</sup>

## FLS

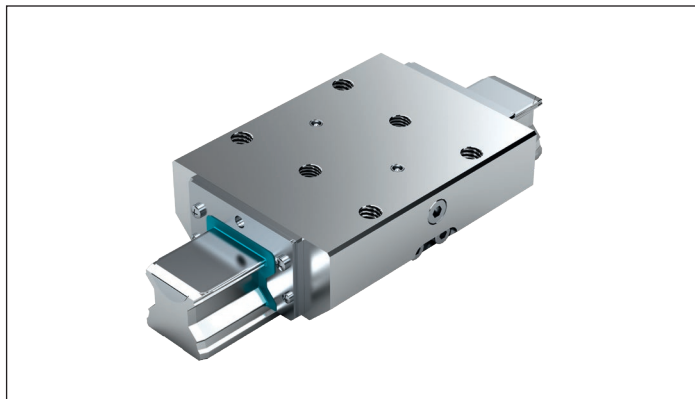

**Note**

Can be used on all SNS roller guide rails.

**Clamps and brakes with compression**

- ▶ Max. hydraulic operating pressure:
- ▶ Size 45 - 65: 150 bar
- ▶ Operating temperature range t: 0 – 70°C

**Note on lubrication**

- ▶ Initial filling of hydraulic oil HLP46
- ▶ Check for compatibility when using different oils
- ▲ Observe the safety instructions on clamping and braking units.

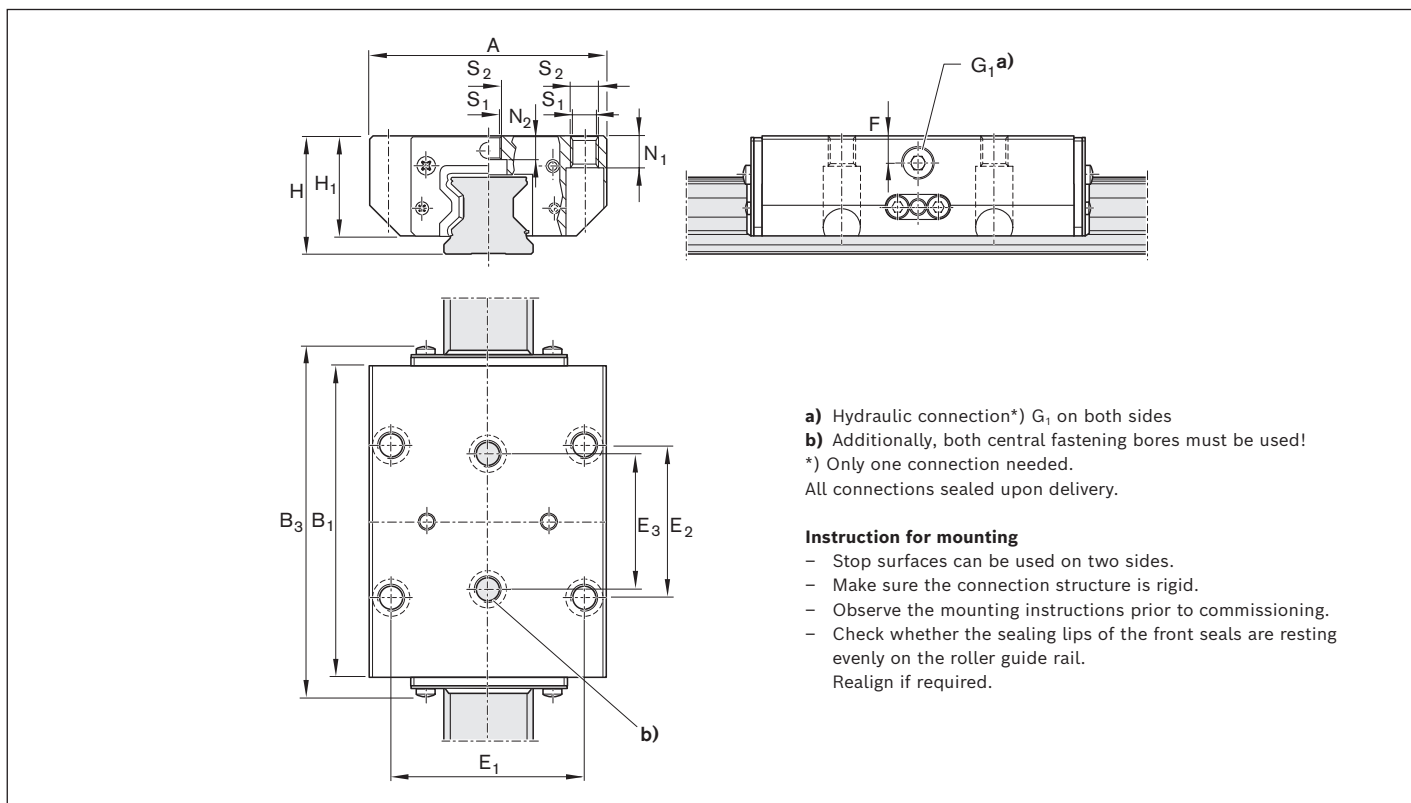

- a) Hydraulic connection\*) G<sub>1</sub> on both sides
  - b) Additionally, both central fastening bores must be used!
  - \*) Only one connection needed.
- All connections sealed upon delivery.

**Instruction for mounting**

- Stop surfaces can be used on two sides.
- Make sure the connection structure is rigid.
- Observe the mounting instructions prior to commissioning.
- Check whether the sealing lips of the front seals are resting evenly on the roller guide rail. Realign if required.

**Material numbers and dimensions**

Size	Material number	Holding force <sup>2)</sup> (N)	Dimensions (mm)														Displacement <sup>6)</sup> (cm <sup>3</sup> )	Mass (kg)
			A	B <sub>1</sub>	B <sub>3</sub>	H	H <sub>1</sub>	E <sub>1</sub>	E <sub>2</sub>	E <sub>3</sub>	F	G <sub>1</sub>	N <sub>1</sub> <sup>4)</sup>	N <sub>2</sub> <sup>5)</sup>	S <sub>1</sub>	S <sub>2</sub>		
45	R1810 440 21	9900 <sup>3)</sup>	120	155.0	174.0	60	51.0	100	80	60	15	1/8"	15	13.5	10.5	M12	1.8	5.2
55	R1810 540 21	13700 <sup>3)</sup>	140	184.0	204.0	70	58.0	116	95	70	16	1/8"	18	13.7	12.5	M14	2.4	8.4
65	R1810 640 21	22700 <sup>3)</sup>	170	227.0	245.0	90	76.0	142	110	82	20	1/4"	23	21.5	14.5	M16	3.8	17.3

1) Zimmer GmbH  
 2) The inspection is done in a mounted state with a lubricated layer (ISO-VG 68).  
 3) At 150 bar  
 4) For bolting from below with ISO 4762  
 5) For bolting from below with DIN 7984  
 6) Per clamping

# Hydraulic clamping and braking units KBH<sup>1)</sup> SLH

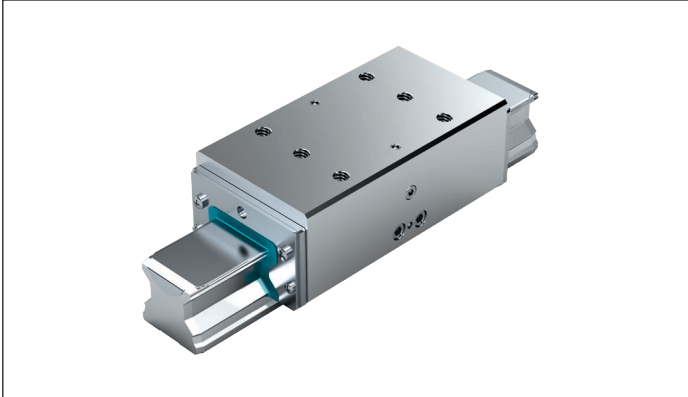

## Note

Can be used on all SNS roller guide rails.

## Clamps and brakes with compression

- ▶ Max. hydraulic operating pressure:
- ▶ Size 45: 110 bar
- ▶ Operating temperature range t: 0 – 70°C

## Note on lubrication

- ▶ Initial filling of hydraulic oil HLP46
- ▶ Check for compatibility when using different oils
- ▲ Observe the safety instructions on clamping and braking units.

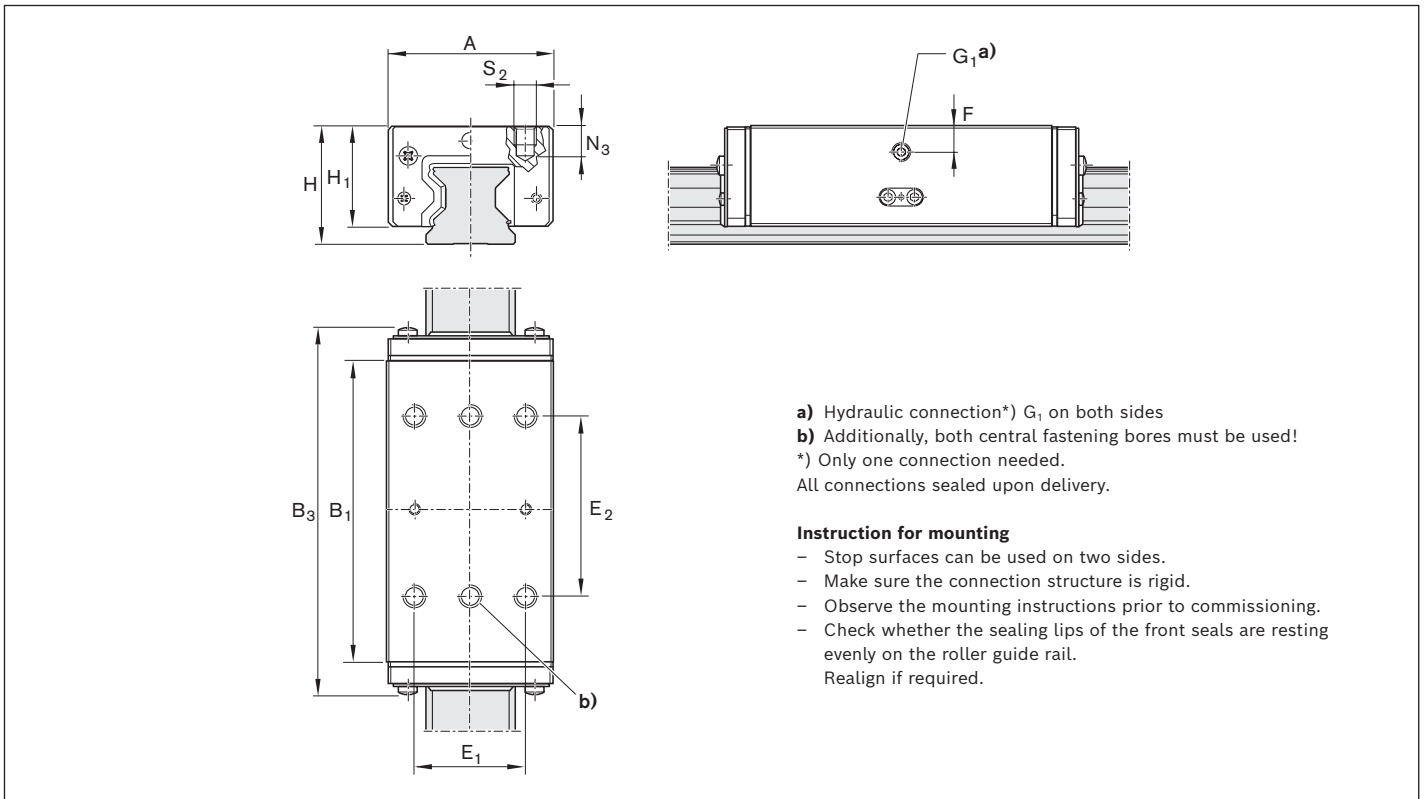

## Material numbers and dimensions

Size	Material number	Holding force <sup>2)</sup> (N)	Dimensions (mm)											Displacement <sup>4)</sup> (cm <sup>3</sup> )	Mass (kg)
			A	B <sub>1</sub>	B <sub>3</sub>	H	H <sub>1</sub>	E <sub>1</sub>	E <sub>2</sub>	F	G <sub>1</sub>	N <sub>2</sub>	S <sub>2</sub>		
45	R1810 440 22	7400 <sup>3)</sup>	86	163	174	70	61	60	80	24	1/8"	18	M10	1.8	5.2

1) Zimmer GmbH

2) The inspection is done in a mounted state with a lubricated layer (ISO-VG 68).

3) At 100 bar

4) Per clamping

# Hydraulic clamping units product description

## Application areas

- ▶ Clamping of heavy handling systems
- ▶ Clamping of machine tables from heavily machined machining centers

## Characteristic features

- ▶ Very high axial holding forces
- ▶ Compact version, compatible with DIN 645
- ▶ Dynamic and static stabilization in the axial direction

**⚠** Observe the safety instructions on clamping and braking units.

## Further highlights

- ▶ Threaded on both sides for the hydraulic connection
- ▶ Solid, rigid steel housing, chemically nickel-plated
- ▶ High positioning accuracy
- ▶ Continuously adjustable pressure from 50 - 150 bar
- ▶ Integrated all-round sealing
- ▶ Special pressure diaphragm technology for maximum functional reliability without pressure losses or leakage
- ▶ Integrated positive-locking, large-surface contact profiles for maximum axial rigidity

## Special features of the hydraulic clamping and braking units (KWH):

- ▶ 10 million clamping cycles (B10d value)

## Functional principle

**Hydraulic pressure: 50 - 150 bar**

### Clamps and brakes with compression

The large-scale clamping profiles are pressed directly through the hydraulic oil via a piston principle to the flanks of the roller guide rail.

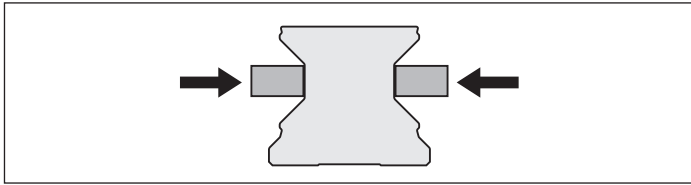

**Hydraulic pressure: 0 bar**

### Decompression with spring force

A preloaded return spring allows for short decompression cycles.

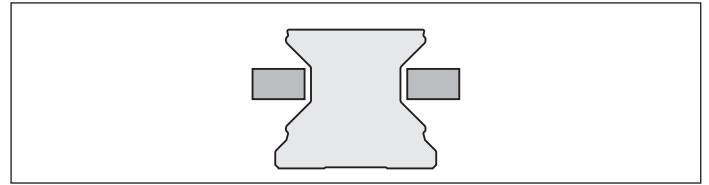

**KWH, FLS**

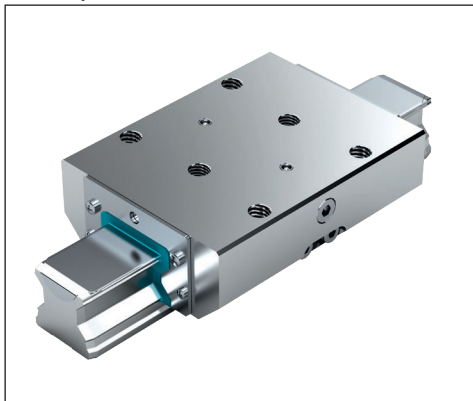

**KWH, SLS**

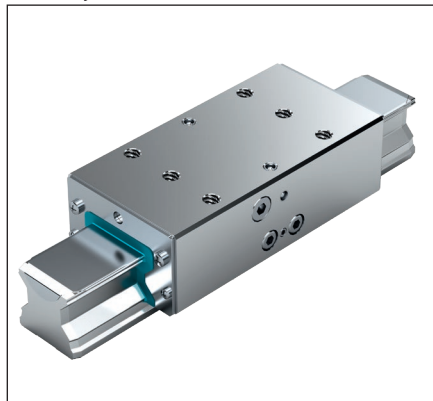

**KWH, SLH**

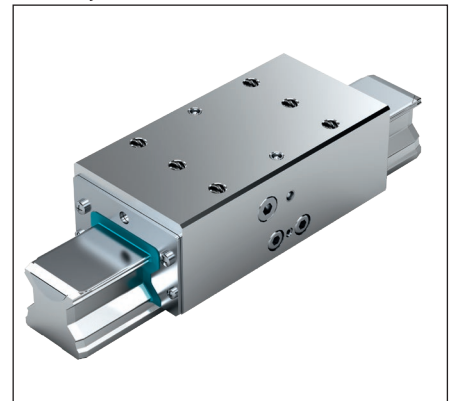

# Hydraulic clamping units KWH<sup>1)</sup> FLS

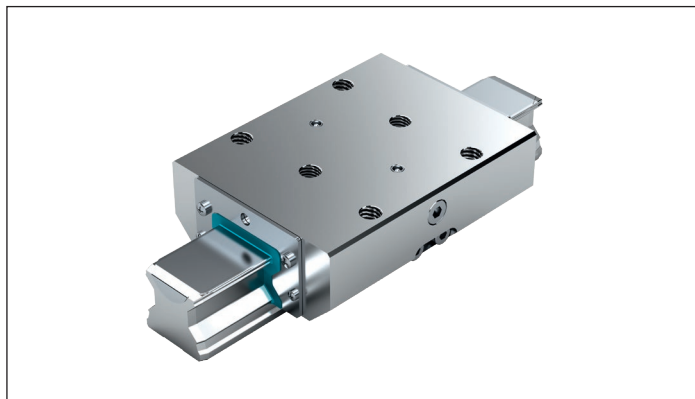

**Note**

Can be used on all SNS roller guide rails.

**Clamps and brakes with compression**

- ▶ Max. hydraulic operating pressure:
- ▶ Size 25: 100 bar
- ▶ Size 35 - 125: 150 bar
- ▶ Operating temperature range t: 0 – 70°C

**Note on lubrication**

- ▶ Initial filling of hydraulic oil HLP46
- ▶ Check for compatibility when using different oils
- ⚠ Observe the safety instructions on clamping and braking units.

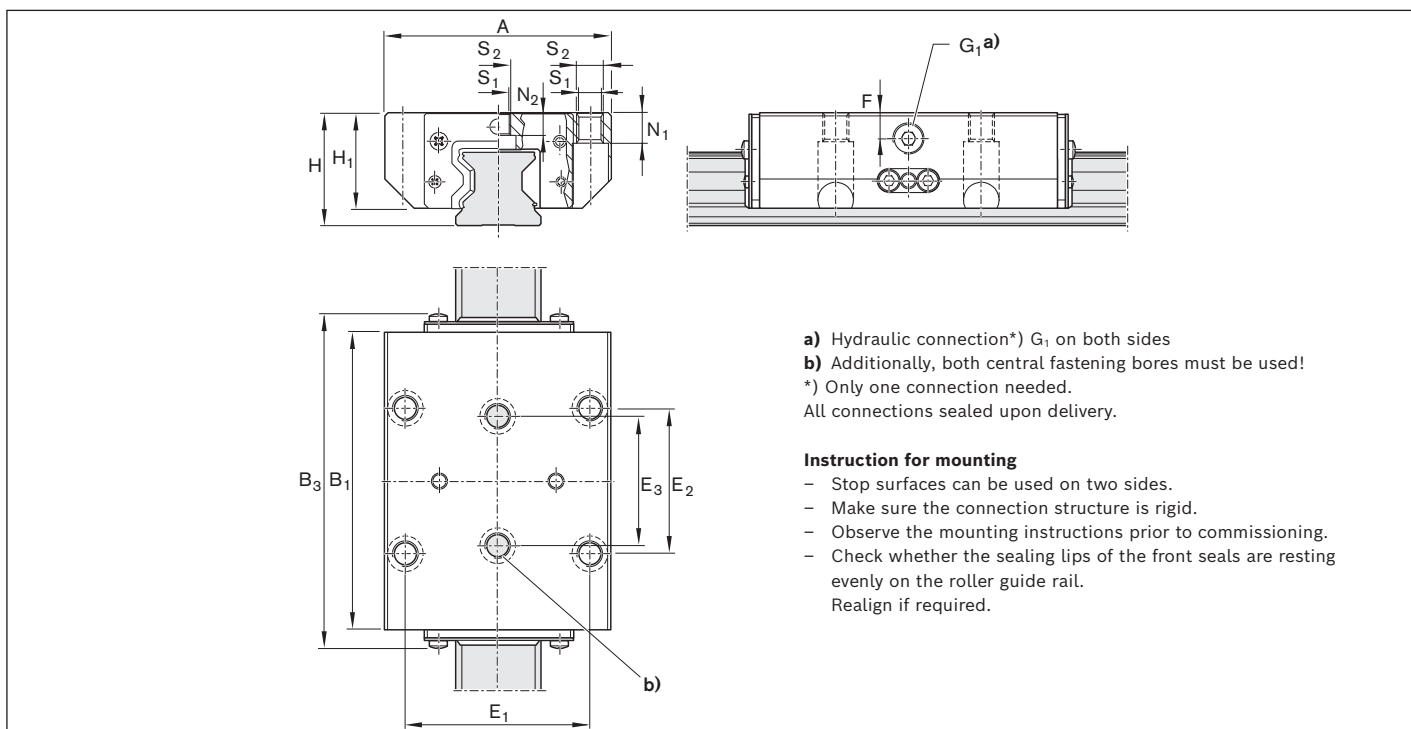

- a) Hydraulic connection\*) G<sub>1</sub> on both sides
  - b) Additionally, both central fastening bores must be used!
  - \*) Only one connection needed.
- All connections sealed upon delivery.

**Instruction for mounting**

- Stop surfaces can be used on two sides.
  - Make sure the connection structure is rigid.
  - Observe the mounting instructions prior to commissioning.
  - Check whether the sealing lips of the front seals are resting evenly on the roller guide rail.
- Realign if required.

**Material numbers and dimensions**

Size	Material number	Holding force <sup>2)</sup> (N)	Dimensions (mm)														Displacement <sup>7)</sup> (cm <sup>3</sup> )	Mass (kg)
			A	B <sub>1</sub>	B <sub>3</sub>	H	H <sub>1</sub>	E <sub>1</sub>	E <sub>2</sub>	E <sub>3</sub>	F	G <sub>1</sub>	N <sub>1</sub> <sup>5)</sup>	N <sub>2</sub> <sup>6)</sup>	S <sub>1</sub>	S <sub>2</sub>		
25	R1810 242 11	2200 <sup>3)</sup>	70	92.0	105.0	36	30.0	57	45	40	9.5	1/8"	9	7.3	6.8	M8	0.6	1.22
35	R1810 342 11	5700 <sup>4)</sup>	100	120.5	135.2	48	41.0	82	62	52	12.0	1/8"	12	11.0	8.6	M10	1.1	2.69
45	R1810 442 11	9900 <sup>4)</sup>	120	155.0	174.0	60	51.0	100	80	60	15.0	1/8"	15	13.5	10.5	M12	1.8	5.32
55	R1810 542 11	13700 <sup>4)</sup>	140	184.0	204.0	70	58.0	116	95	70	16.0	1/8"	18	13.7	12.5	M14	2.4	8.40
65	R1810 642 11	22700 <sup>4)</sup>	170	227.0	245.0	90	76.0	142	110	82	20.0	1/4"	23	21.5	14.5	M16	3.8	17.30
100	R1810 243 11	34000 <sup>4)</sup>	250	200.0	221.6	120	105.0	200	150	150	20.0	1/4"	30	17.5	17.5	M20	5.0	29.1
125	R1810 343 11	46000 <sup>4)</sup>	320	227.0	245.0	160	135.0	270	102.5	102.5	50.0	1/4"	45	29.0	24.0	M27	7.6	53.7

1) Zimmer GmbH

2) The inspection is done in a mounted state with a lubricated layer (ISO-VG 68). For permissible holding forces see "Technical data and calculations".

3) At 100 bar

4) At 150 bar

5) For bolting from below with ISO 4762

6) For bolting from below with DIN 7984

7) Per clamping

# Hydraulic clamping units KWH<sup>1)</sup> SLS

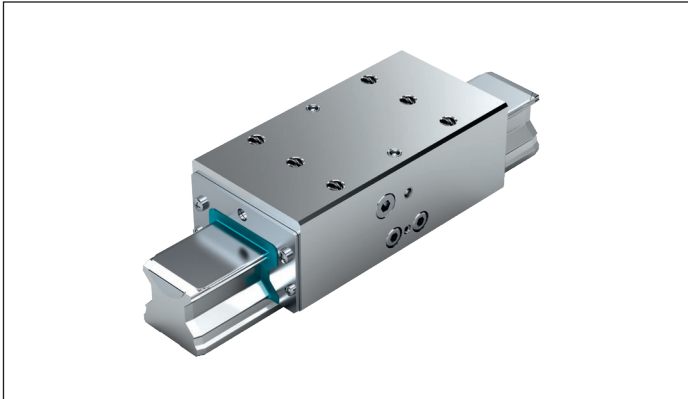

## Note

Can be used on all SNS roller guide rails.

## Clamps and brakes with compression

- ▶ Max. hydraulic operating pressure:
- ▶ Size 65: 150 bar
- ▶ Operating temperature range t: 0 – 70°C

## Note on lubrication

- ▶ Initial filling of hydraulic oil HLP46
- ▶ Check for compatibility when using different oils
- ▲ Observe the safety instructions on clamping and braking units.

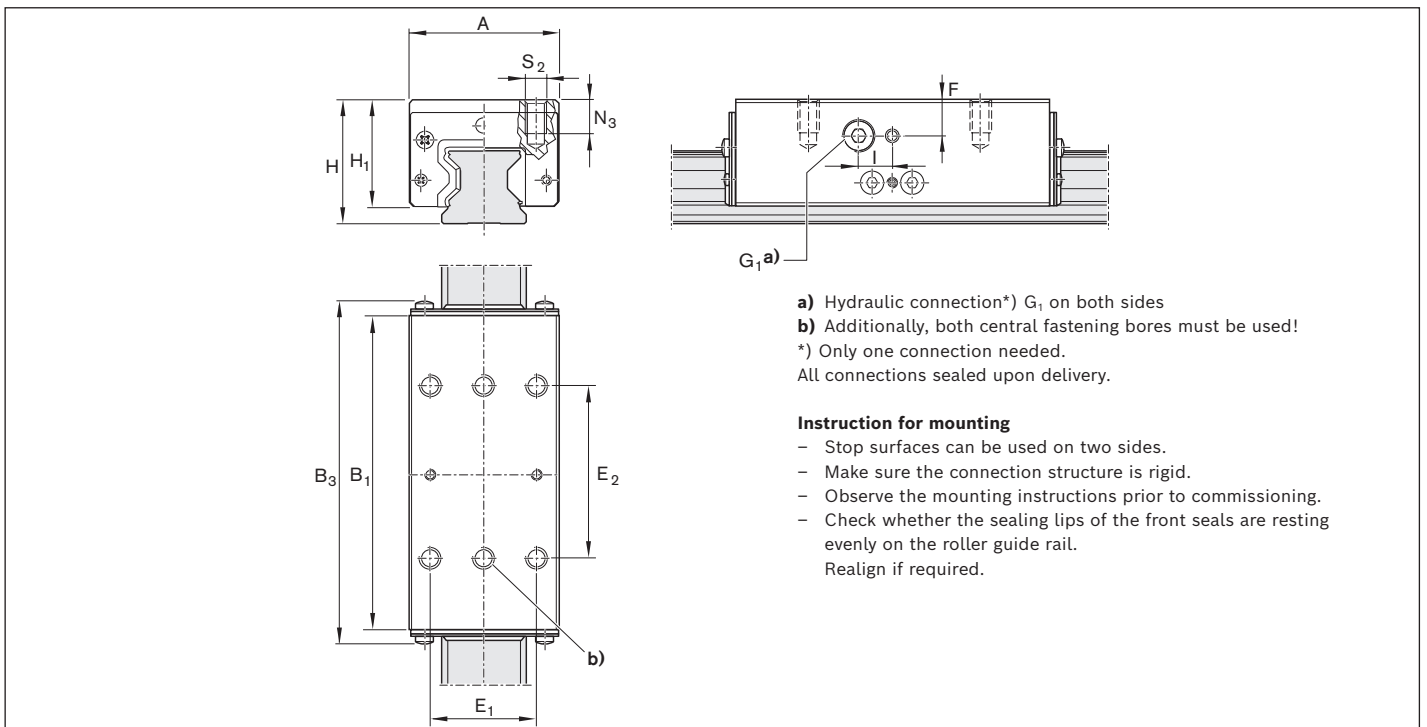

## Material numbers and dimensions

Size	Material number	Holding force <sup>2)</sup> (N)	Dimensions (mm)											Displacement <sup>4)</sup> (cm <sup>3</sup> )	Mass (kg)
			A	B <sub>1</sub>	B <sub>3</sub>	H	H <sub>1</sub>	E <sub>1</sub>	E <sub>2</sub>	F	G <sub>1</sub>	N <sub>3</sub>	S <sub>2</sub>		
65	R1810 642 51	22700 <sup>3)</sup>	126	227.0	245.1	90	76.0	76	120	20	1/4"	21	M16	3.8	15.4

1) Zimmer GmbH

2) The inspection is done in a mounted state with a lubricated layer (ISO-VG 68). For permissible holding forces see "Technical data and calculations".

3) At 150 bar

4) Per clamping

# Hydraulic clamping units KWH<sup>1)</sup> SLH

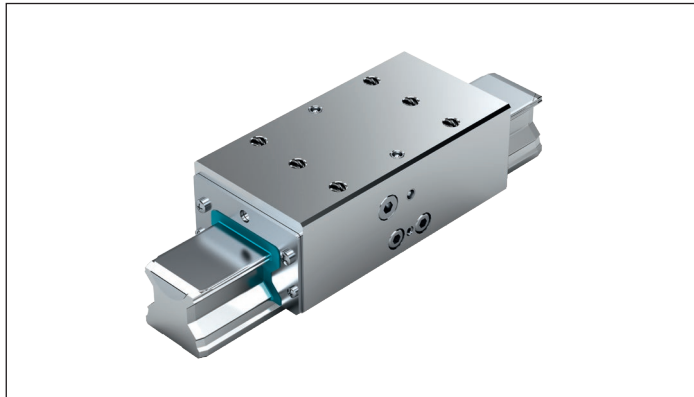

**Note**

Can be used on all SNS roller guide rails.

**Clamps and brakes with compression**

- ▶ Max. hydraulic operating pressure:
- ▶ Size 25 - 45: 100 bar
- ▶ Size 55: 150 bar
- ▶ Operating temperature range t: 0 – 70°C

**Note on lubrication**

- ▶ Initial filling of hydraulic oil HLP46
- ▶ Check for compatibility when using different oils
- ⚠ Observe the safety instructions on clamping and braking units.

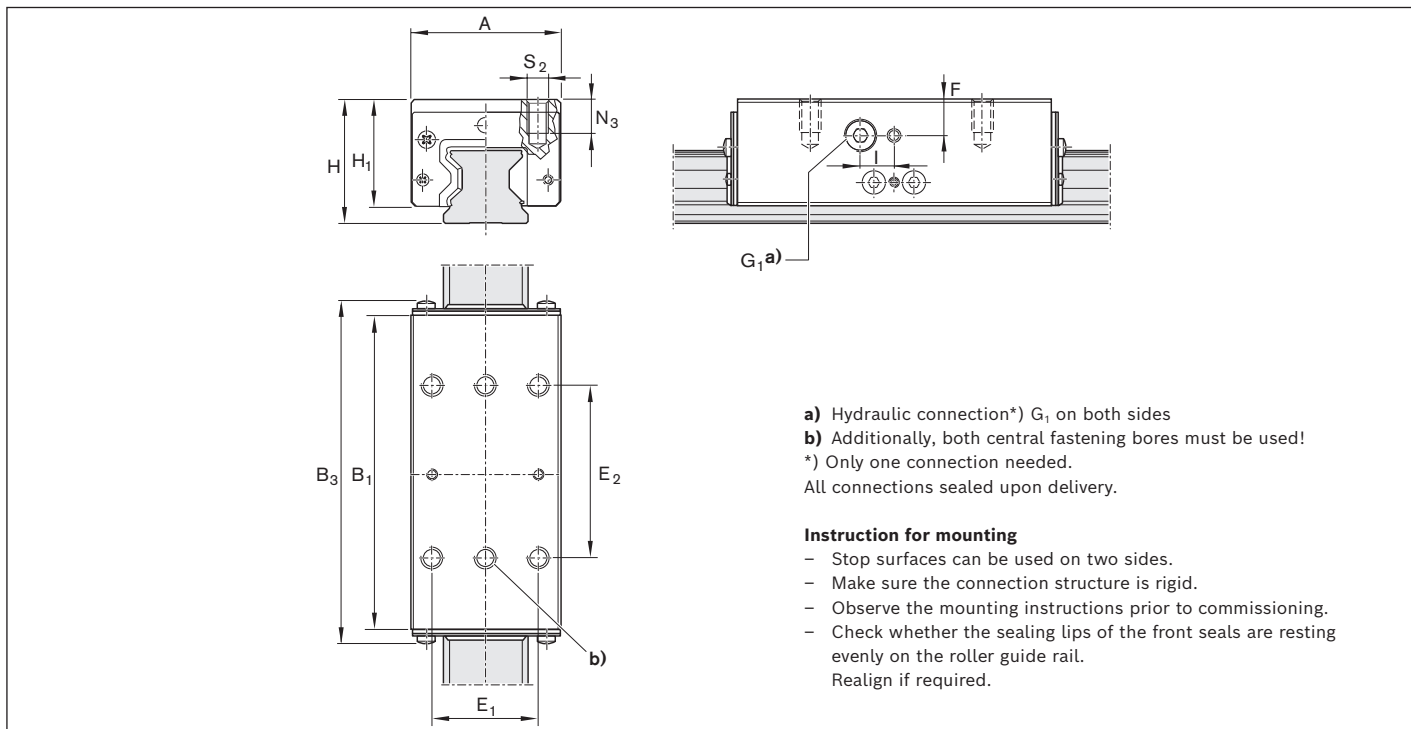

**Material numbers and dimensions**

Size	Material number	Holding force <sup>2)</sup> (N)	Dimensions (mm)													Displacement <sup>5)</sup> (cm <sup>3</sup> )	Mass (kg)
			A	B <sub>1</sub>	B <sub>3</sub>	H	H <sub>1</sub>	E <sub>1</sub>	E <sub>2</sub>	F	G <sub>1</sub>	i	N <sub>3</sub>	S <sub>2</sub>			
25	R1810 242 31	1600 <sup>3)</sup>	48	92.0	100.0	40	33.5	35	50	12	1/8"	10	12	M6	0.6	1.10	
35	R1810 342 31	3500 <sup>3)</sup>	70	120.5	135.2	55	48.0	50	72	18	1/8"	-	13	M8	1.1	2.46	
45	R1810 442 31	7400 <sup>3)</sup>	86	155.0	174.0	70	61.0	60	80	24	1/8"	-	18	M10	1.8	4.95	
55	R1810 542 31	13700 <sup>4)</sup>	100	184.0	204.0	80	68.0	75	95	26	1/8"	-	19	M12	2.4	7.90	

1) Zimmer GmbH

2) The inspection is done in a mounted state with a lubricated layer (ISO-VG 68). For permissible holding forces see "Technical data and calculations".

3) At 100 bar

4) At 150 bar

5) Per clamping



# Pneumatic clamping and braking units, product description

## Application areas

### Clamping

- ▶ In the event of loss of pressure
- ▶ During assembly work and standstill of the machine without energy
- ▶ Of machine tables from machining centers
- ▶ Of z-axis positioning in the resting position

### Brakes

- ▶ In the event of energy failure
- ▶ In the event of a pressure drop
- ▶ Support of the emergency stop function
- ▶ Support as brake for linear motors

**⚠** Observe the safety instructions on clamping and braking units.

## Characteristic features

- ▶ Clamps and brakes with spring energy accumulator
- ▶ Positive-locking integrated contact profiles ensure maximum axial and horizontal rigidity, and thus an excellent braking effect
- ▶ Dynamic and static stability in axial direction

### Special features MBPS/UBPS:

- ▶ 5 million clamping cycles (B10d value)

## Functional principle

### Air pressure: 0 bar

#### Clamps and brakes with spring force

In the event of a pressure drop, the clamping or braking effect is generated via a dual acting gate valve gear mechanism, each with one spring assembly (spring energy accumulator).

An integrated quick-exhaust valve ensures short response times.

### Air pressure: 4.5 - 8 bar (MBPS)

#### 5.5 - 8 bar (UBPS)

#### Decompression with air pressure

The clamping profiles are held apart by the compressed air.

- ▶ Free movement is possible

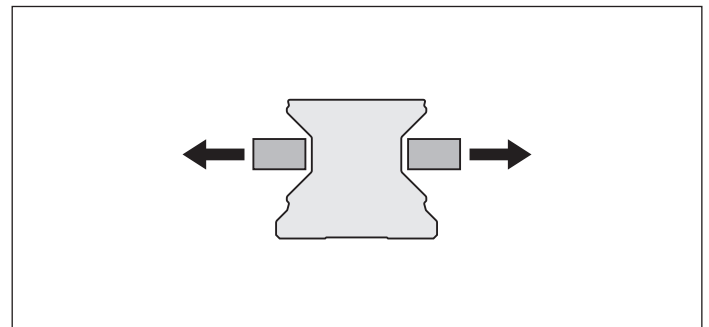
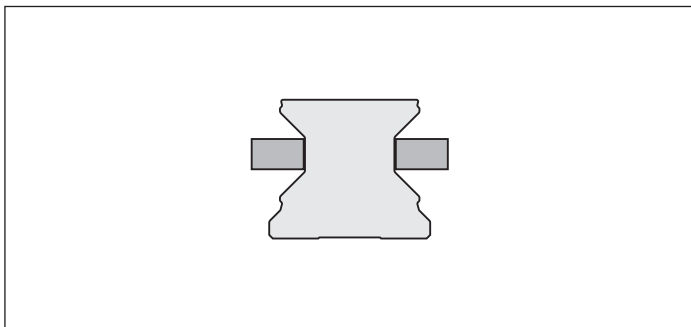

## Further highlights

- ▶ Up to 1 million clamping cycles
- ▶ Up to 2,000 emergency braking operations
- ▶ Integrated all-round sealing
- ▶ High continuous output
- ▶ High positioning accuracy
- ▶ Mechanical gate valve gear mechanism
- ▶ Solid, rigid steel housing, chemically nickel-plated
- ▶ Low air consumption
- ▶ Maintenance-free

### Special features of MBPS:

- ▶ Clamping and braking units in short format
- ▶ Add-ons with three pistons connected in series combined with strong springs result in holding forces up to 4700 N at just 4.5 bar release pressure.
- ▶ 5 million clamping cycles (B10d value)<sup>1)</sup>

### Special features of UBPS:

- ▶ Very high axial holding forces of up to 7700 N at 5.5 bar release pressure with high-power spring energy accumulator.
- ▶ Increased holding force of up to 9200 N thanks to additional pressurization on the air-plus port
- ▶ Extremely low air consumption
- ▶ Compact version, compatible with DIN 645
- ▶ 5 million clamping cycles (B10d value)<sup>1)</sup>

1) B10d value is not achieved with PLUS connection

## MBPS

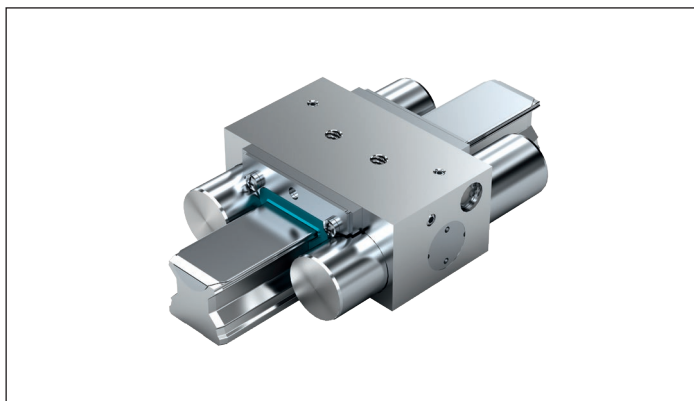

## UBPS

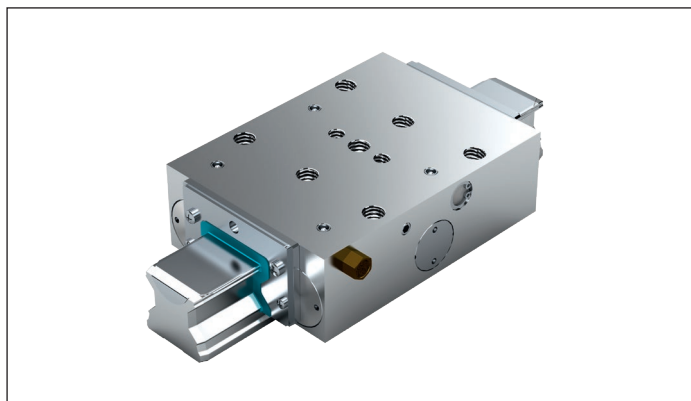

# Pneumatic clamping and braking units MBPS<sup>1)</sup>

## R1810 .40 31

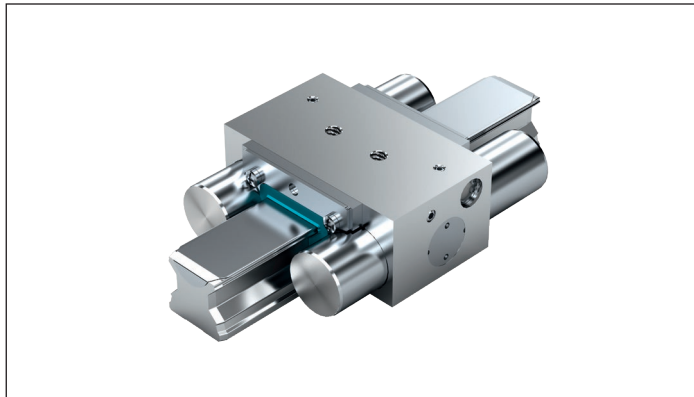

### Note

- ▶ Can be used on all SNS roller guide rails.

### Clamps and brakes without pressurization (spring energy)

- ▶ Minimum release pressure 4.5 bar
- ▶ Maximum pneumatic operating pressure: 8 bar
- ▶ Operating temperature range t: 0 – 70°C

### Instruction for mounting

- ▶ Make sure the connection structure is rigid.
- ▶ Use only purified air. The prescribed filter mesh size is 25 µm.
- ▶ Observe the mounting instructions prior to commissioning.
- ▶ Check whether the sealing lips of the front seals are resting evenly on the roller guide rail. Realign if required.

- ⚠ Observe the safety instructions on clamping and braking units.

### Circuit for standard air port

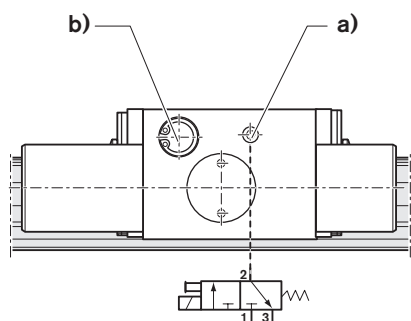

- 1 Air port
- 2 Working connections
- 3 Venting

### Technical data

Size	Material number	Holding force Spring energy <sup>2)</sup> (N)	Air consumption (normal liter) Air port (dm <sup>3</sup> /stroke)	Mass (kg)
25	R1810 240 31	1300	0.048	1.0
35	R1810 340 31	2600	0.093	1.9
45	R1810 440 31	3600	0.099	2.3
55	R1810 540 31	4700	0.244	3.7

1) Zimmer GmbH

2) Holding force achieved by spring energy. The inspection is done in a mounted state with a lubricated layer (ISO-VG 68).

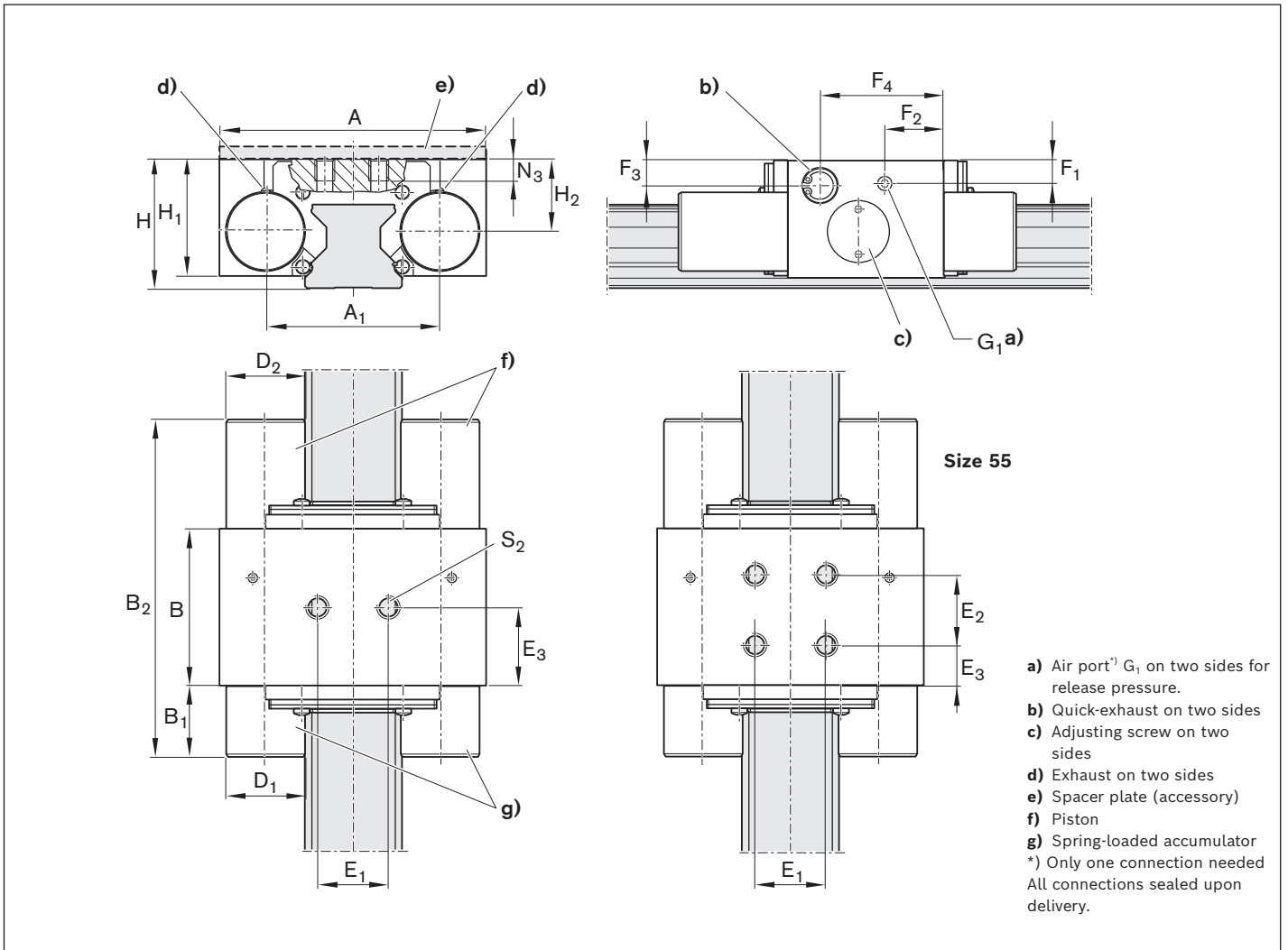
**Dimensions (mm)**

Size	A	A <sub>1</sub>	B	B <sub>1</sub>	B <sub>2 max</sub>	D <sub>1</sub>	D <sub>2</sub>	E <sub>1</sub>	E <sub>2</sub>	E <sub>3</sub>
25	75	49.0	44	20.2	93.4	22	22	20	-	22.0
35	100	68.0	46	27.7	105.7	28	28	24	-	24.5
45	120	78.8	49	32.2	113.2	30	30	26	-	24.5
55	140	97.0	62	41.0	144.0	39	39	38	38	12.0

Size	F <sub>1</sub>	F <sub>2</sub>	F <sub>3</sub>	F <sub>4</sub>	G <sub>1</sub>	H	H <sub>1</sub> <sup>1)</sup>	H <sub>2</sub>	N <sub>3</sub>	S <sub>2</sub>
25	6.5	16.5	7.0	34.7	M5	36	32.5	20.0	8	M6
35	9.0	19.0	9.5	38.0	G1/8"	48	42.0	26.5	10	M8
45	15.0	31.1	12.2	41.6	G1/8"	60	52.0	35.5	15	M10
55	11.0	23.0	11.0	40.0	M5	70	59.0	38.0	18	M10

1) For roller runner block .H. (High) spacer plate required.

# Pneumatic clamping and braking units UBPS<sup>1)</sup>

## R1810 .40 51

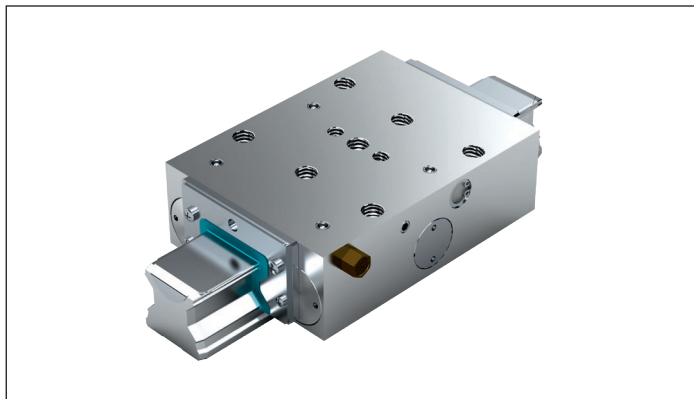

**Very high axial holding forces due to three pistons connected in series combined with strong spring energy accumulator; increased holding force thanks to additional pressure through the air-plus port.**

### Note

- ▶ Can be used on all SNS roller guide rails.

### Clamps and brakes without pressurization (spring energy)

- ▶ Minimum release pressure 5.5 bar
- ▶ Maximum pneumatic operating pressure: 8 bar
- ▶ Operating temperature range t: 0 – 70°C

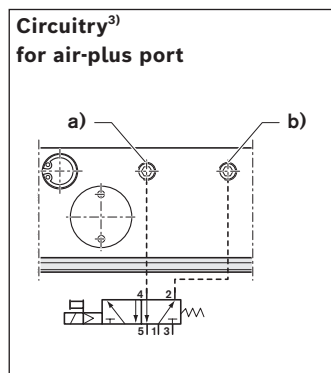
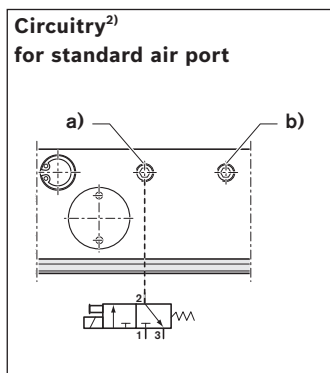

- 1 Air port  
2 4 Working connections  
3 5 Venting

### Instruction for mounting

- ▶ Stop surfaces can be used on two sides.
- ▶ Make sure the connection structure is rigid.
- ▶ Use only purified air.  
The prescribed filter mesh size is 25 µm.
- ▶ Observe the mounting instructions prior to commissioning.
- ▶ Check whether the sealing lips of the front seals are resting evenly on the roller guide rail. Realign if required.

- ⚠ Observe the safety instructions on clamping and braking units.

### Technical data

Size	Material number	Holding force achieved by spring energy <sup>2)</sup>		Air consumption (normal liter)		Mass (kg)
		Air port (N)	With air-plus port <sup>3)</sup> (N)	Air port (dm <sup>3</sup> /stroke)	Air-plus port (dm <sup>3</sup> /stroke)	
25	R1810 240 51	1500	2200	0.080	0.165	1.20
35	R1810 340 51	2800	3800	0.139	0.303	2.25
45	R1810 440 51	5200	7600	0.153	0.483	6.20
55	R1810 540 51	7700	9200	0.554	0.952	9.40

1) Zimmer GmbH

2) Holding force achieved by spring energy. The inspection is done in a mounted state with a lubricated layer (ISO-VG 68).

3) Increased holding force by additional air admission at air-plus port with 6.0 bar. Switching via 5/2 or 5/3-way directional control valve.

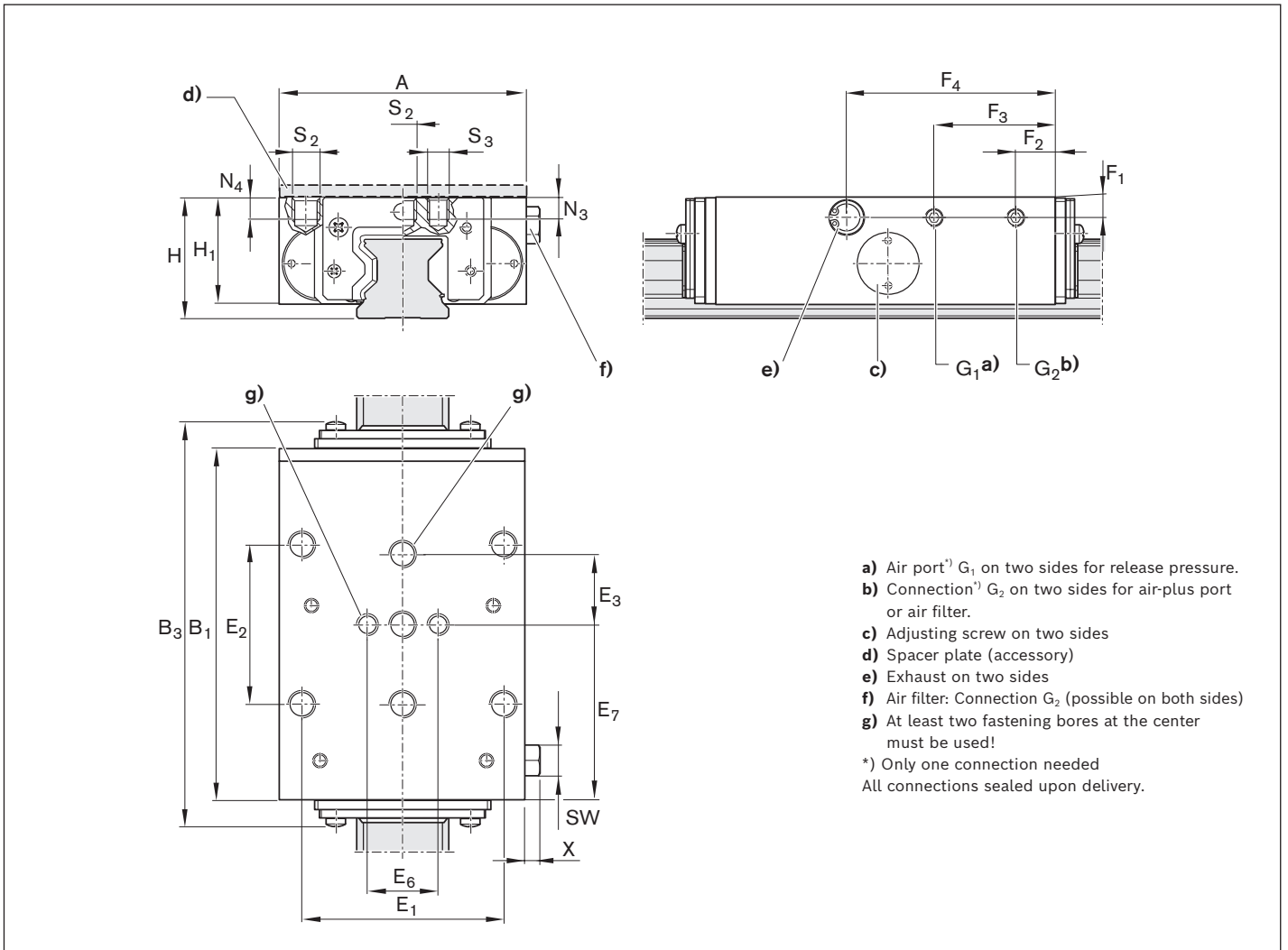
**Dimensions (mm)**

Size	A	B <sub>1</sub>	B <sub>3 max</sub>	E <sub>1</sub>	E <sub>2</sub>	E <sub>3</sub>	E <sub>6</sub>	E <sub>7</sub>	F <sub>1</sub>	F <sub>2</sub>	F <sub>3</sub>	F <sub>4</sub>
25	70	99	111.8	57	45	20	20	49.5	6.5	11.0	34.3	59.0
35	100	109	123.8	82	62	26	24	54.5	8.0	11.0	40.8	66.5
45	120	199	215.4	100	80	30	-	99.5	12.0	32.0	167.0	106.5
55	140	197	214.8	116	95	35	-	98.5	13.0	32.0	165.0	103.5

Size	G <sub>1</sub>	G <sub>2</sub>	H	H <sub>1</sub> <sup>1)</sup>	N <sub>3</sub>	N <sub>4</sub>	S <sub>2</sub>	S <sub>3</sub>	X	SW
25	M5	M5	36	31	7	7	M8	M6	5.5	Ø8, SW7
35	G1/8"	G1/8"	48	42	10	10	M10	M8	6.5	Ø15, SW13
45	G1/8"	G1/8"	60	52	-	12	M12	-	6.5	Ø15, SW13
55	G1/8"	G1/8"	70	60	-	14	M14	-	6.5	Ø15, SW13

1) For roller runner block .H. (High) spacer plate required.

# Product description

## pneumatic clamping units

### Application areas

#### Clamping

- ▶ Pneumatic clamping of machine axes
- ▶ Table crossbars in the timber industry
- ▶ Positioning of lifting gear

**⚠** Observe the safety instructions on clamping and braking units.

### Characteristic features

- ▶ High axial holding forces with short format
- ▶ Dynamic and static stability in axial direction

### Functional principle MK

**Air pressure: 4.0 - 8 bar**

#### Clamps with air pressure

For MK, the clamping profiles are pressed by compressed air to the web surfaces of the roller guide rail via a dual acting gate valve gear mechanism.

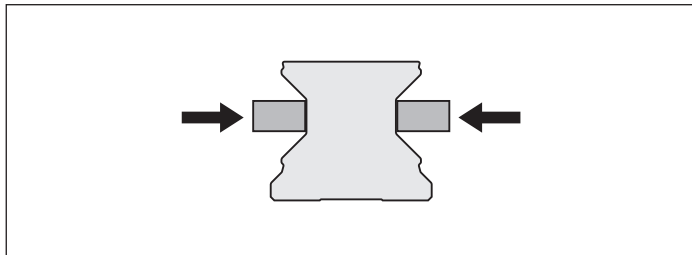

**Air pressure: 0 bar**

#### Decompression with spring force

A preloaded return spring allows for short decompression cycles.

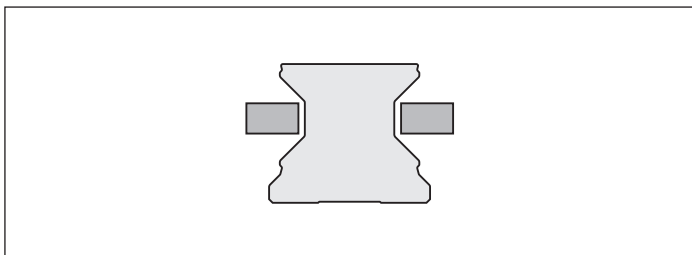

### Functional principle MKS

**Air pressure: 0 bar**

#### Clamps with spring force

In the event of a pressure drop, the MKS clamps via a dual acting gate valve gear mechanism, each with one spring assembly (spring energy accumulator). An integrated quick-exhaust valve ensures short response times.

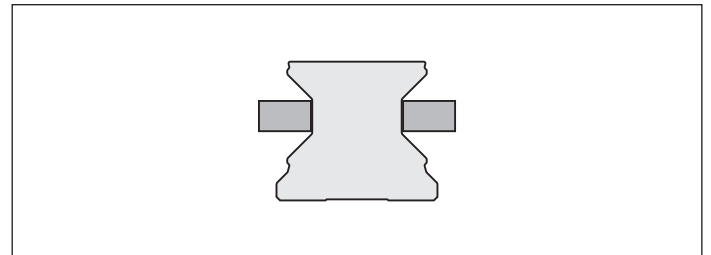

**Air pressure: 5.5 - 8 bar**

#### Decompression with air pressure

The clamping profiles are held apart by the compressed air.

- ▶ Free movement is possible

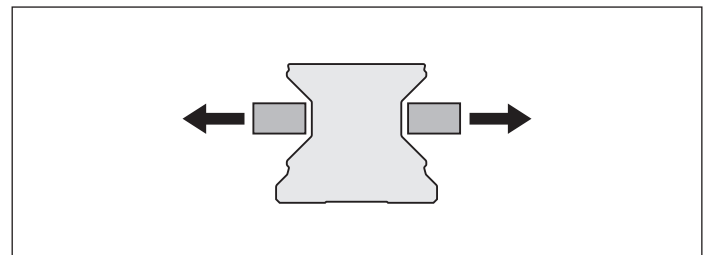

## Further highlights

- ▶ Easy mounting
- ▶ Chemically nickel-plated steel housing
- ▶ High axial and horizontal rigidity
- ▶ Precise positioning

### Special features of MK:

- ▶ Clamps with pressure (pneumatic) via a dual acting gate valve gear mechanism
- ▶ Continuously adjustable pressure from 4 - 8 bar
- ▶ Short decompression cycles
- ▶ 5 million clamping cycles (B10d value)

### Special features of MKS:

- ▶ Clamps without pressurization (spring energy) via the gate valve gear mechanism with two spring assemblies
- ▶ Release pressure 5.5 bar (pneumatic)
- ▶ Higher holding force due to the air-plus port
- ▶ 5 million clamping cycles (B10d value)\*)

\*) with the air-plus port, the B10d value cannot be achieved

**MK**

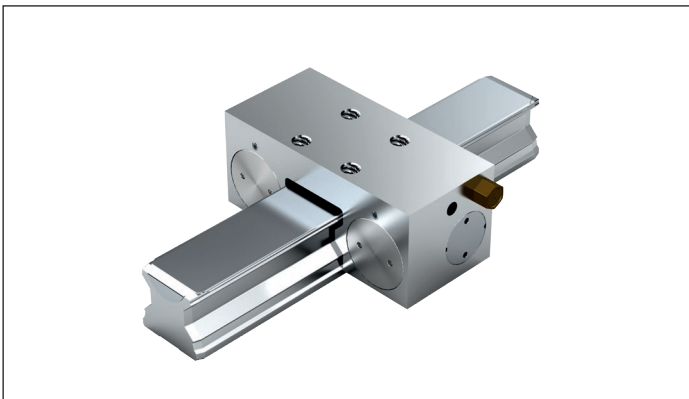

**MKS**

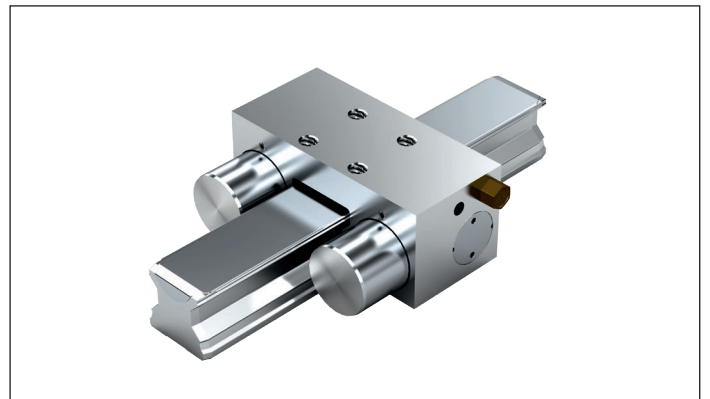

# Pneumatic clamping units MK<sup>1)</sup>

## R1810 .42 60

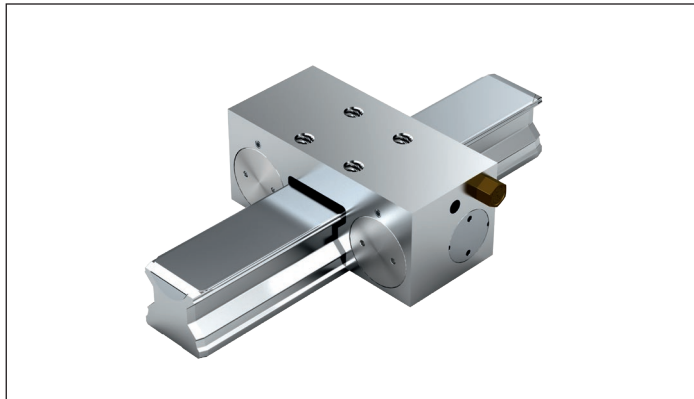

### Note

- ▶ Can be used on all SNS roller guide rails.

### Clamps with pressure

- ▶ Maximum pneumatic operating pressure: 8 bar
- ▶ Operating temperature range t: 0 – 70°C

### Instruction for mounting

- ▶ Make sure the connection structure is rigid.
- ▶ Use only purified air. The prescribed filter mesh size is 25 µm.
- ▶ Observe the mounting instructions prior to commissioning.

- ⚠ Observe the safety instructions on clamping and braking units.

### Circuit for standard air port

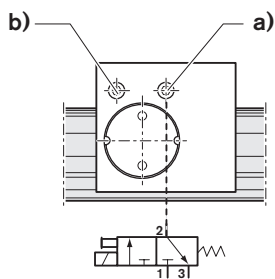

- 1 Air port
- 2 Working connections
- 3 Venting

### Technical data

Size	Material number	Pneumatic holding force <sup>2)</sup> (N)	Air consumption (normal liter) (dm <sup>3</sup> /stroke) Air port	Mass (kg)
25	R1810 242 60	1200	0.021	0.45
35	R1810 342 60	2000	0.031	0.88
45	R1810 442 60	2250	0.041	1.70
55	R1810 542 60	2250	0.041	1.95
65	R1810 642 60	2250	0.041	2.68

1) Zimmer GmbH

2) Holding force at 6 bar. The inspection is done in a mounted state with a lubricated layer (ISO-VG 68).

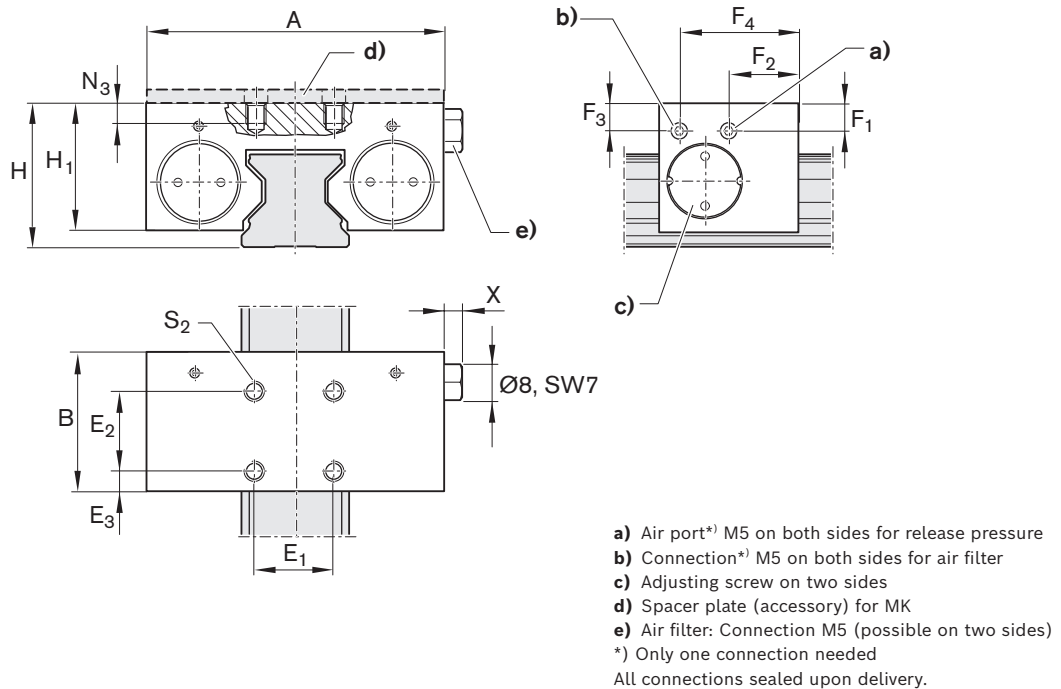
**Dimensions (mm)**

Size	A	B	E <sub>1</sub>	E <sub>2</sub>	E <sub>3</sub>	F <sub>1</sub>	F <sub>2</sub>	F <sub>3</sub>	F <sub>4</sub>	H	H <sub>1</sub> <sup>1)</sup>	N <sub>3</sub>	S <sub>2</sub>	X
<b>25</b>	75	35	20	20	5.0	6.5	17.5	6.5	30.0	36	32.5	8.0	M6	5.5
<b>35</b>	100	39	24	24	7.5	11.0	14.5	12.0	24.5	48	44.0	10.0	M8	5.5
<b>45</b>	120	49	26	26	11.5	14.5	19.5	14.5	29.5	60	52.0	15.0	M10	5.5
<b>55</b>	128	49	30	30	9.5	17.0	19.5	17.0	29.5	70	57.0	15.0	M10	5.5
<b>65</b>	138	49	30	30	9.5	14.5	19.5	14.5	29.5	90	73.5	20.0	M10	5.5

1) For roller runner block .H. (High) spacer plate required.

# Pneumatic clamping units MKS<sup>1)</sup> R1810 .40 60

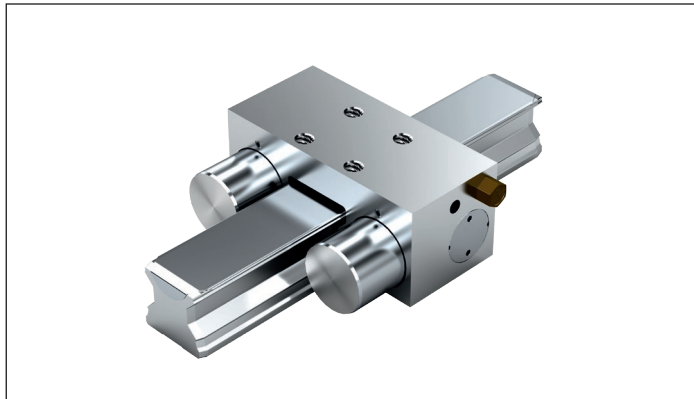

### Note

- ▶ Can be used on all SNS roller guide rails.

### Clamps without pressurization (spring energy)

- ▶ Minimum release pressure 5.5 bar
- ▶ Maximum pneumatic operating pressure: 8 bar
- ▶ Operating temperature range t: 0 – 70°C

### Instruction for mounting

- ▶ Make sure the connection structure is rigid.
- ▶ Use only purified air. The prescribed filter mesh size is 25 µm.
- ▶ Observe the mounting instructions prior to commissioning.

- ⚠ Observe the safety instructions on clamping and braking units.

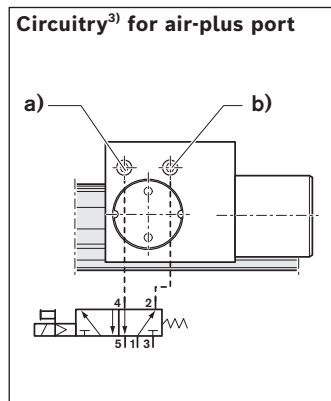
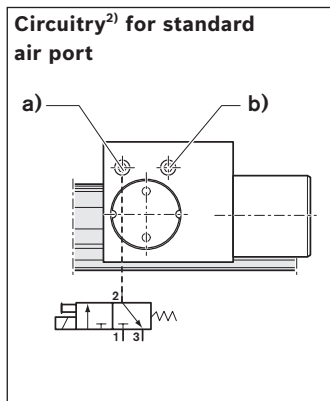

- 1 Air port
- 2 4 Working connections
- 3 5 Venting

### Technical data

Size	Material number	Holding force, spring energy <sup>2)</sup> (N)		Air consumption (normal liter) (dm <sup>3</sup> /stroke)		Mass (kg)
		Air port	with air-plus port <sup>3)</sup>	Air port	Air-plus port	
25	R1810 240 60	750	1500	0.021	0.068	0.50
35	R1810 340 60	1250	3250	0.031	0.129	1.00
45	R1810 440 60	1450	3300	0.041	0.175	1.84
55	R1810 540 60	1450	3300	0.041	0.175	2.08
65	R1810 640 60	1450	3300	0.041	0.175	2.86

- 1) Zimmer GmbH
- 2) Holding force achieved by spring energy. The inspection is done in a mounted state with a lubricated layer (ISO-VG 68).
- 3) Increased holding force by additional air admission at air-plus port with 6.0 bar. Switching via 5/2 or 5/3-way directional control valve.

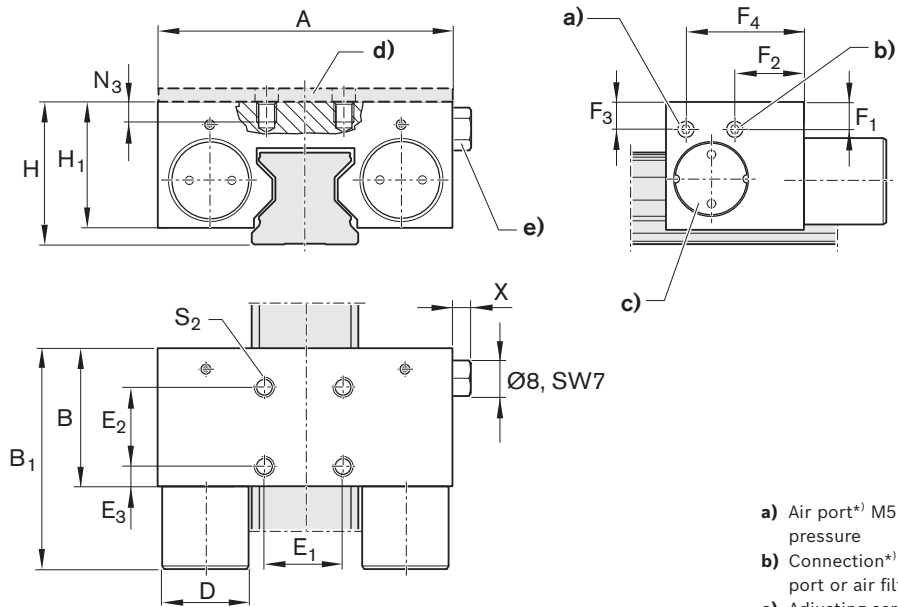

- a) Air port<sup>\*)</sup> M5 on both sides for release pressure
  - b) Connection<sup>\*)</sup> M5 on both sides for air-plus port or air filter
  - c) Adjusting screw on two sides
  - d) Spacer plate (accessory) for MKS
  - e) Air filter: Connection M5 (possible on two sides)
- <sup>\*)</sup> Only one connection needed  
All connections sealed upon delivery.

**Dimensions (mm)**

Size	A	A <sub>1</sub>	B	B <sub>1</sub>	D	E <sub>1</sub>	E <sub>2</sub>	E <sub>3</sub>	F <sub>1</sub>	F <sub>2</sub>	F <sub>3</sub>	F <sub>4</sub>	H	H <sub>1</sub> <sup>1)</sup>	H <sub>2</sub>	N <sub>3</sub>	S <sub>2</sub>	X
<b>25</b>	75	49.0	35	56	22	20	20	5.0	6.5	30.0	6.5	17.5	36	32.5	20.0	8.0	M6	5.5
<b>35</b>	100	68.0	39	67	28	24	24	7.5	12.0	24.5	11.0	14.5	48	44.0	28.0	10.0	M8	5.5
<b>45</b>	120	78.8	49	82	30	26	26	11.5	14.5	29.5	14.5	19.5	60	52.0	35.5	15.0	M10	5.5
<b>55</b>	128	86.8	49	82	30	30	30	9.5	17.0	29.5	17.0	19.5	70	57.0	40.0	15.0	M10	5.5
<b>65</b>	138	96.8	49	82	30	30	30	9.5	14.5	29.5	14.5	19.5	90	73.5	55.0	20.0	M10	5.5

1) For roller runner block .H. (High) spacer plate required.

# Manual clamping units, spacer plates, product description

## Manual clamping units

### Application areas

- ▶ Table crossbars and MSC slides
- ▶ Width adjustment
- ▶ Stops
- ▶ Positioning on optical devices and measuring tables

### Characteristic features

- ▶ Simple and safe structural design in compact format
- ▶ Manually operated clamping unit without auxiliary power

### Special features of HK:

- ▶ 500,000 clamping cycles (B10d value)

**!** Observe the safety instructions on clamping and braking units.

## Functional principle of HK

### Pressure via hand lever

#### Clamps with manual pressure

The clamping profiles are pressed to the web surfaces of the roller guide rail by the hand lever.

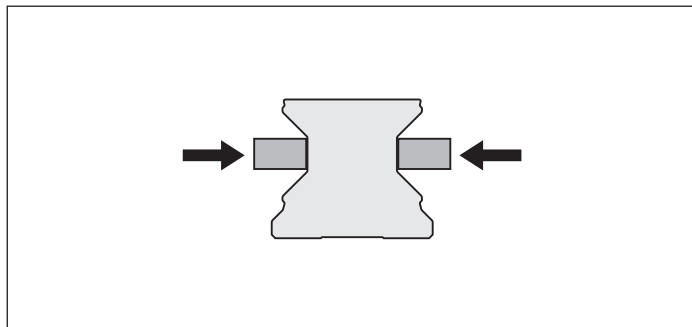

### Decompress by loosening the hand lever

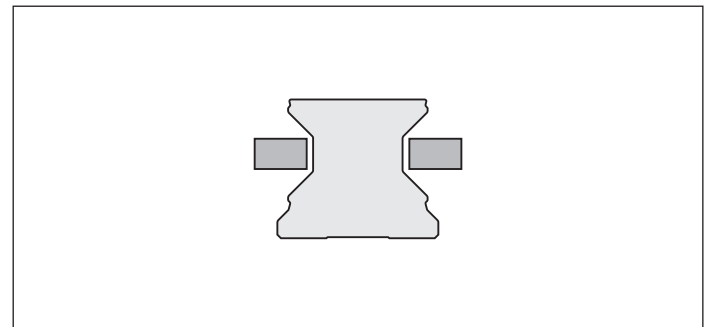

## Further highlights

- ▶ Freely adjustable hand lever
- ▶ Symmetrical force application on roller guide rail via floating contact profiles
- ▶ Precise positioning
- ▶ Holding forces up to 2000 N

## Manual clamping unit HK

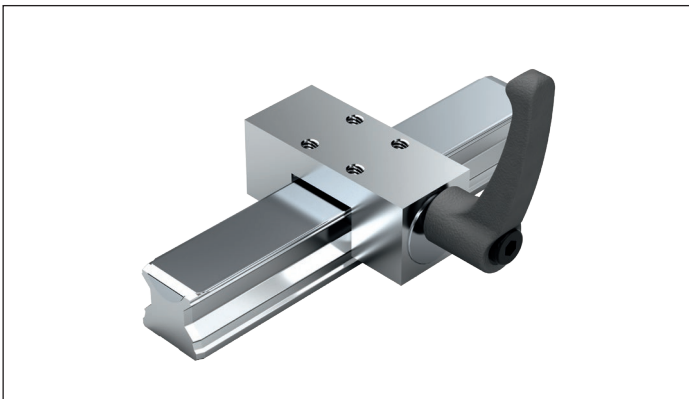

## Spacer plate

Suitable for mounting with roller runner block high for SNH R1821 and SLH R1824.

For clamping units MK, MKS and HK



# Manual clamping unit HK<sup>1)</sup>

## R1619 .42 82

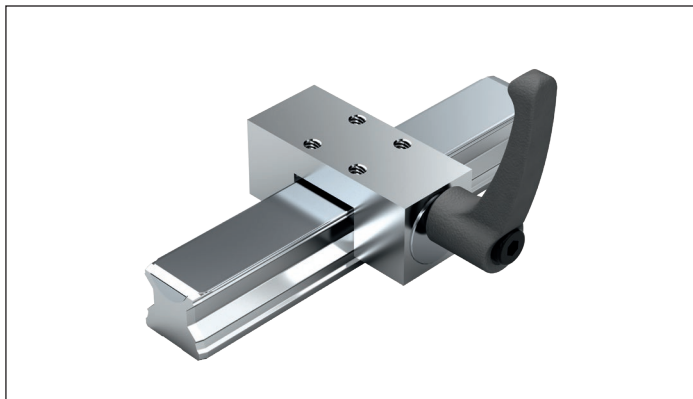

**Note**

Can be used on all SNS roller guide rails.

**Manual clamping unit**

► Operating temperature range t: 0 – 70°C

**Instruction for mounting**

- Make sure the connection structure is rigid.
- Observe the mounting instructions prior to commissioning.

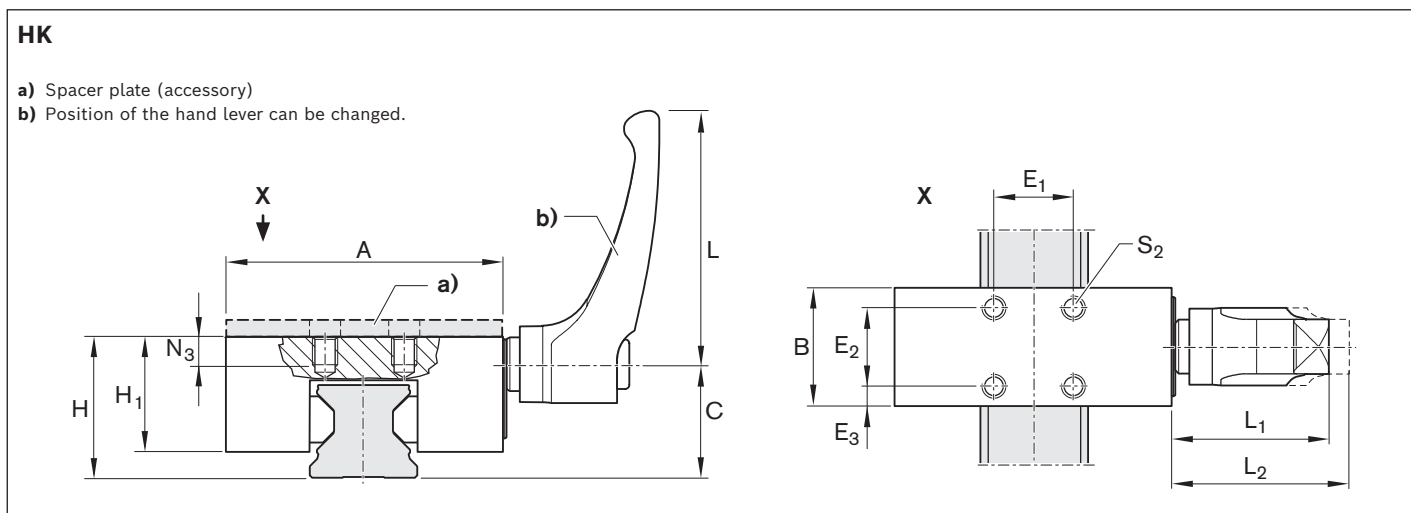

Size	Material number	Holding force <sup>2)</sup> (N)	Tightening torque (Nm)
25	R1619 242 82	1200	7
35	R1619 342 82	2000	15
45	R1619 442 82	2000	15
55	R1619 542 82	2000	22
65	R1619 642 82	2000	22

Size	Dimensions (mm)													Mass (kg)
	A	B	C	E <sub>1</sub>	E <sub>2</sub>	E <sub>3</sub>	H	H <sub>1</sub> <sup>4)</sup>	L	L <sub>1</sub>	L <sub>2</sub> <sup>3)</sup>	N <sub>3</sub>	S <sub>2</sub>	
25	70	30	29.3	20	20	5.0	36	29	64	38.5	41.5	7	M6	0.43
35	100	39	38.0	24	24	7.5	48	41	78	46.5	50.5	10	M8	1.08
45	120	44	47.0	26	26	9.0	60	48	78	46.5	50.5	14	M10	1.64
55	140	49	56.5	30	30	9.5	70	51	95	56.5	61.5	14	M14	1.71
65	160	64	69.5	35	35	14.5	90	66	95	56.5	61.5	20	M16	2.84

- 1) Zimmer GmbH
- 2) The inspection is done in a mounted state with a lubricated layer (ISO-VG 68).
- 3) Hand lever disengaged
- 4) For roller runner block .H. (...High ...) Spacer plate necessary

# Spacer plate for MK, MKS, HK<sup>1)</sup>

**Note**

Suitable for mounting with roller runner block high for SNH R1821 and SLH R1824.

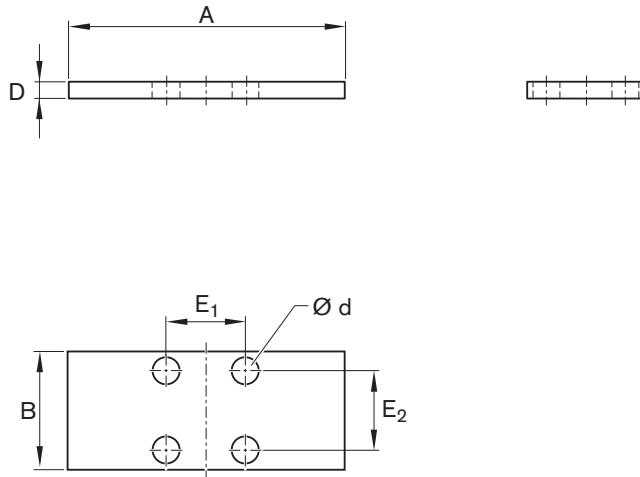
**Spacer plate**

**R1619 .40 65**
**Suitable for clamping units:**

- ▶ R1810 .42 60 (MK)
- ▶ R1810 .40 60 (MKS)

**Material numbers and dimensions**

Size	Material number	Dimensions (mm)						Mass (kg)
		A	B	D	d	E <sub>1</sub>	E <sub>2</sub>	
25	R1619 240 65	75	35	4	6.5	20	20	0.078
35	R1619 340 65	100	39	7	8.5	24	24	0.202
45	R1619 440 65	120	49	10	10.5	26	26	0.434
55	R1619 540 65	128	49	10	10.5	30	30	0.465

**R1619 .42 .5**
**Suitable for clamping units:**

- ▶ R1619 .42 82 (HK)

**Material numbers and dimensions**

Size	Material number	Dimensions (mm)						Mass (kg)
		A	B	D	d	E <sub>1</sub>	E <sub>2</sub>	
25	R1619 242 85	70	30	4	6.5	20	20	0.062
35	R1619 340 65	100	39	7	8.5	24	24	0.202
45	R1619 442 85	120	44	10	10.5	26	26	0.387
55	R1619 542 85	140	49	10	14.5	30	30	0.511

1) Zimmer GmbH

# Clamping and braking units, safety instructions

## General safety instructions

- ⚠ During all work on the clamping units, the respective valid instructions by UVV, VDE, the safety notes and instruction for mounting are to be observed!
- ⚠ The clamping units do not have any guiding function. Therefore, it is not possible to replace a roller runner block with a clamping unit. The ideal position of the clamping unit lies between two roller runner blocks. When using several clamping units, these should be distributed evenly on both roller guide rails in order to attain a maximum rigidity of the overall construction.
- ⚠ For hydraulic clamping and braking units, the return pressure in the tank line must be lower than 1.5 bar!
- ⚠ Consider the response times of the clamping and braking units!
- ⚠ The clamping unit is not intended for securing suspended loads!
- ⚠ Do not remove the cover of the safety clamping unit - spring under tension!
- ⚠ The transport lock may only be removed if:
  - The hydraulic port has been pressurized with the operating pressure according to instructions.
  - The air port has been pressurized with compressed air to at least 4.5 bar (MBPS) or 5.5 bar (UBPS, MKS) according to instructions.
- ⚠ The clamping unit may only be de-pressurized when the appropriate roller guide rail or transport lock is in position between the contact profiles!
- ⚠ The use of clamping and braking units is not permissible on roller guide rails with integrated measuring systems.

### **Additional notes for clamping and braking units**

- ⚠ The clamping and braking units are suitable for usage in safety-critical applications for braking and clamping. The safe function of the total system in which the clamping and braking units are used is primarily defined by the controller for this system. The technical configuration of this system and the controller is to be undertaken by the manufacturer of the higher level system, assembly, plant or machine. During this process the safety-related requirements for functional safety are to be observed.

### **Additional notes for clamping units**

- ⚠ The unit may not be used as a braking unit! For use only when the axis is at a standstill!
- ⚠ Pressure may only be applied when the unit is properly mounted on the roller guide rail!

# General instructions for mounting

## General notes

The following mounting notes apply to all roller rail systems.

Rexroth Roller rail systems are high-grade quality products. Use with extreme care during transport and mounting. The same care must be taken with cover strips.

All steel parts are protected with anti-corrosion oil. It is not necessary to remove this oil, provided that the recommended lubricants are used.

**⚠** In overhead mounting orientations (suspended top down) the roller runner block could possibly come away from the roller guide rail due to loss or breakage of rollers. Secure the roller runner block against falling!

## Mounting with mounting runner block

Use the middle bore D in the mounting runner block to measure exactly in the center, then fasten the roller guide rail with the mounting runner block.

### Aligning the rails

1. Align and mount the first roller guide rail using a graduated straightedge.
2. Set up a mounting bridge with dial gauge between the Roller runner blocks.
3. Move both roller runner blocks in parallel until bore D in the mounting runner block is positioned precisely above a fastening bore in the rail.
4. Align the roller guide rail manually until the dial gauge shows the correct dimension.
5. Then screw down the roller guide rail using the Mounting Runner Block.

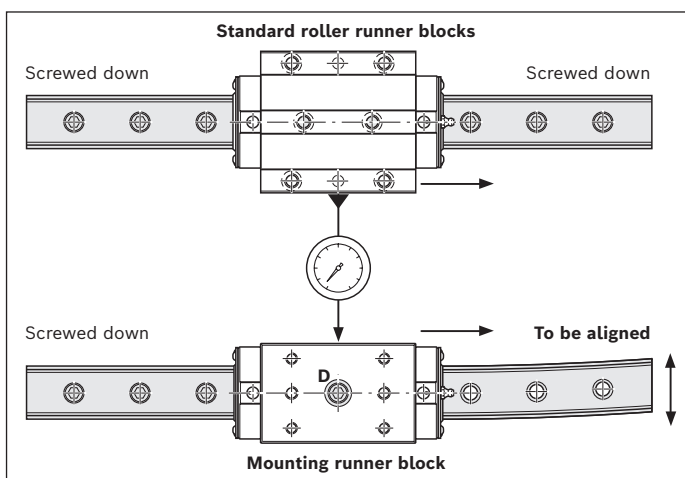

## Flatness of mounting surfaces

### Flatness of the runner block support $E_1$

See table 1.

### Flatness of Guide Rail support $E_2$

Recommendation: Use the values for the parallelism offset  $P_1$  of the roller rail system in operation (see diagram 1).

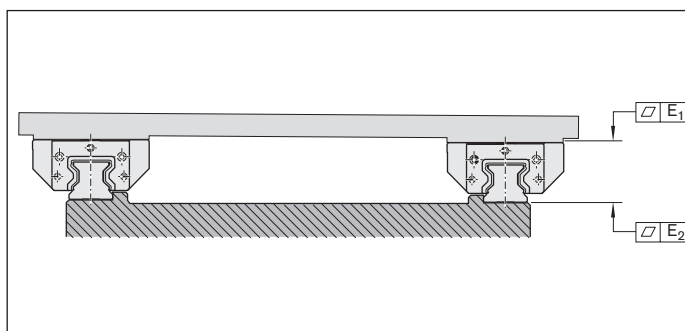

Size	Flatness ( $\mu\text{m}$ )
25	0.5
35	0.8
45	1.0
55	1.0
65	2.0
100	2.0
125	3.0

Table 1

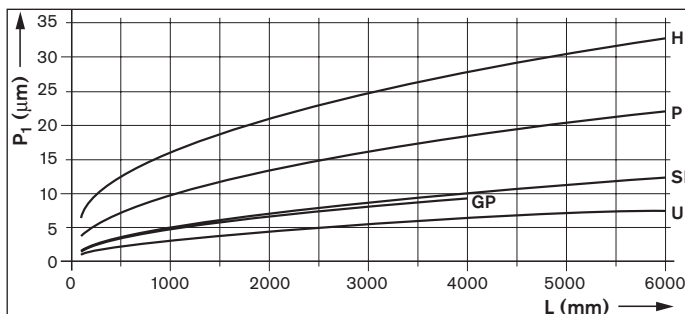

Diagram 1

### Key to illustration

$P_1$  = Parallelism offset ( $\mu\text{m}$ )  
 L = Rail length (mm)

## Installation tolerances

### Basic principles

Installation tolerances generate constraining forces. They can lead to increased displacement resistance, heat generation, load on the adjacent construction, reduced accuracy and reduced service life. The same applies to thermal expansions, deformations or subsidence.

The amount of constraining forces largely depends on the rigidity of the guideway and the adjacent construction. Exact determination is only possible with numerical calculation.

The surrounding structure must be sufficiently rigid to absorb the loads that occur. If the mating surfaces are unstable, the internal constraining forces on the rolling element set and the screw load increase (see DIN 637).

### Principle

The stiffer the guideway and structure, the smaller the permissible tolerances in order to avoid constraining forces.

### Calculation process

If the vertical offsets  $S_1$  and  $S_2$  as well as the parallelism offset  $P_1$  calculated in the following chapter are observed, the impact on the service life can be generally neglected.

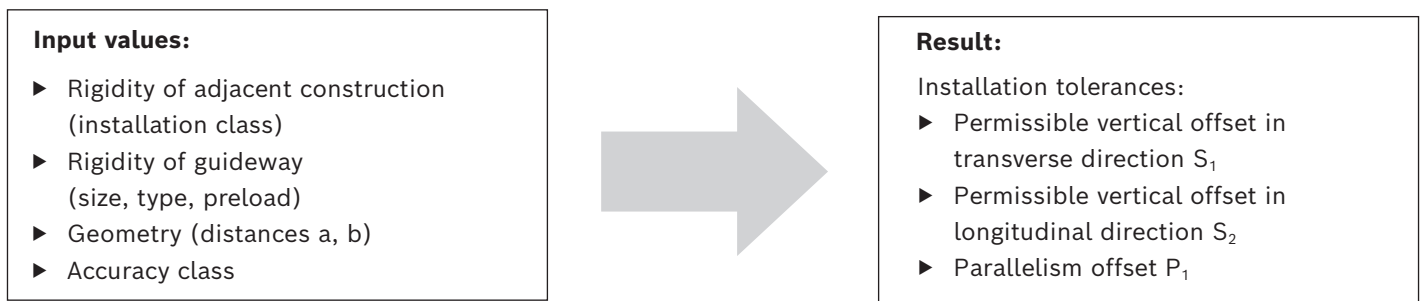

If the tolerances for  $S_1$ ,  $S_2$  or  $P_1$  are negative or cannot be maintained, the following measures can be taken:

- ▶ Selection of higher accuracy classes
- ▶ Reduction of the installation class by reducing the rigidity of the connection design
- ▶ Increase of runner block spacing a and/or b
- ▶ Change in the assembly concept, e.g. by aligning or tuning
- ▶ Calculation of service life reduction

# General instructions for mounting

## Installation classes

The rigidity of the adjacent construction is taken into account in the installation factor f:

Installation class	Description	Typical accuracy	Installation factor f	Typical industries
Standard	Flexible surrounding construction	H/P	2.0	Automation technology, assembly and handling technology
Precision	Rigid surrounding construction	P/SP	1.5	Machine tools for cutting, forming and dividing
Super precision	Highly rigid surrounding construction	SP/UP	1.0	High-precision machine tool for machining, forming and cutting

## Vertical offset

Permissible vertical offset in transverse direction  $S_1$

$$S_1 = f \cdot a \cdot Y - T_{S1} - T_{S1CR}$$

- a = Roller guide rail centerline-to-centerline distance [mm]
- f = Installation factor (installation class) [1]
- $S_1$  = Permissible vertical offset of the roller guide rail [mm]
- $T_{S1}$  = Accuracy class tolerance in transverse direction [mm]
- $T_{S1CR}$  = Reduction for coated guide rails and runner blocks [mm]  
Standard  $T_{S1CR} = 0$ , with Resist CR see below
- Y = Calculation factor in transverse direction [1]

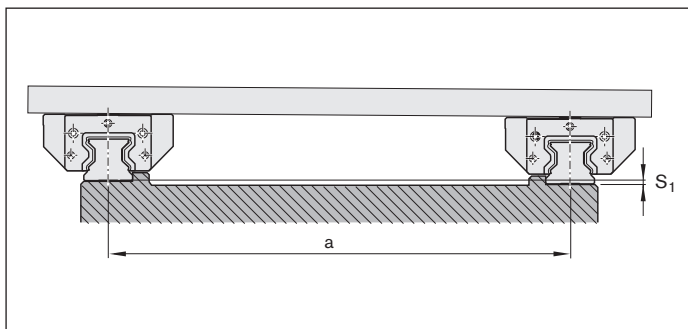

Calculation factor	for preload class	
	C2	C3
Y	$1.7 \cdot 10^{-4}$	$1.2 \cdot 10^{-4}$

With accuracy class tolerance in transverse direction  $T_{S1}$  [mm]:

		Roller guide rail				
		H	P	SP	UP	GP
Roller runner block	H	0.080	0.048	0.030	0.022	0.020
	P	0.072	0.040	0.022	0.014	0.012
	SP	0.070	0.038	0.020	0.012	0.010
	UP	0.068	0.036	0.018	0.010	0.008

**Permissible vertical offset in longitudinal direction  $S_2$** 

$$S_2 = f \cdot b \cdot X - T_{S2} - T_{S2CR}$$

- $b$  = Roller runner block centerline-to-centerline distance [mm]  
 $f$  = Installation factor (installation class) [1]  
 $S_2$  = Permissible vertical offset of the roller guide rail [mm]  
 $T_{S2}$  = Accuracy class tolerance in longitudinal direction [ $\mu\text{m}$ ]  
 $T_{S2CR}$  = Reduction for coated guide rails and runner blocks [ $\mu\text{m}$ ];  
 Standard  $T_{S2CR} = 0$ , with Resist CR see below  
 $X$  = Calculation factor in longitudinal direction [1]

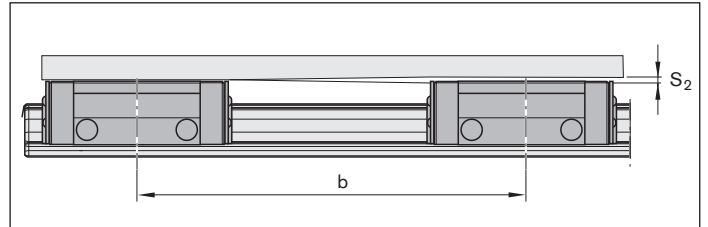

Calculation factor	for roller runner block length		
	Standard length	Long	Extra long
<b>X</b>	$4.3 \cdot 10^{-5}$	$3.0 \cdot 10^{-5}$	$2.2 \cdot 10^{-5}$

 With accuracy class tolerance in longitudinal direction  $T_{S2}$  [mm]:

		Roller guide rail				
		H	P	SP	UP	GP
Roller runner block	H	0.015	0.015	0.015	0.015	0.015
	P	0.007	0.007	0.007	0.007	0.007
	SP	0.005	0.005	0.005	0.005	0.005
	UP	0.003	0.003	0.003	0.003	0.003

**Permissible parallelism offset  $P_1$  of guide rails**

$$P_1 = f \cdot P_{pr} - P_{1CR}$$

- $f$  = Installation factor (installation class) [1]  
 $P_1$  = Permissible parallelism offset [mm]  
 $P_{1CR}$  = Reduction for coated guide rails and runner blocks [ $\mu\text{m}$ ];  
 Standard  $T_{S2CR} = 0$ , with Resist CR see below  
 $P_{pr}$  = Parallelism offset with preload class [mm]

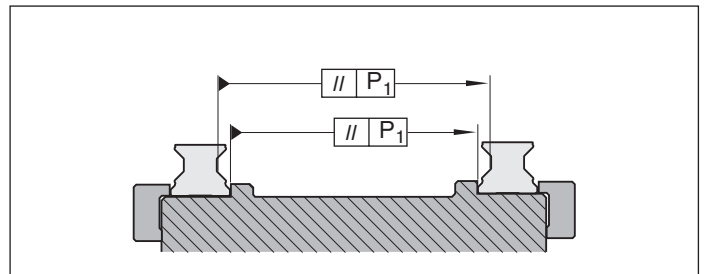
 With parallelism offset  $P_{pr}$  [mm]:

Preload class		C2	C3
Standard	25	0.007	0.005
	35	0.010	0.007
	45	0.012	0.009
	55	0.016	0.011
	65	0.022	0.016
Heavy-duty	65 FXS	0.022	0.016
	100	0.029	0.022
	125	0.034	0.026

## General instructions for mounting

### Chrome-plated guide rails and runner blocks Resist CR

Due to the coating process, rail and runner block have higher tolerances. If at least one of the two elements is coated, the installation tolerances on the customer side are reduced and the following factors must be taken into account in the above formulae:

<b>Permissible vertical offset in transverse direction <math>S_1</math></b>	$T_{S1CR} = 0.005 \text{ mm}$
<b>Permissible vertical offset in longitudinal direction <math>S_2</math></b>	$T_{S2CR} = 0.003 \text{ mm}$
<b>Permissible parallelism offset <math>P_1</math></b>	$P_{1CR} = 0.002 \text{ mm}$

#### Roller runner block normal

- ▶ Standard Roller Rail System FNS R1851, SNS R1822, SNH R1821
- ▶ Heavy-duty roller rail system FNS R1861

#### Roller runner block long

- ▶ Standard roller rail system FLS R1853, SLH R1824, SLS R1823
- ▶ Heavy-duty roller rail system FLS R1863

#### Roller runner block, extra long

- ▶ Heavy-duty roller rail system FXS R1854

## Delivery of the roller guide rails

### One-piece roller guide rails

Standard: One-piece roller guide rails with cover strip are shipped with the cover strip clipped on, both ends angled down and with protective caps screwed on.

If required, roller guide rails can also be supplied with a separate cover strip.

### Composite roller guide rails

The cover strip and protective caps are supplied complete with screws and washers in a separate packaging unit.

The packaging unit is marked with the same manufacturing job number as the labels on the roller guide rails.

The cover strips have one angled down and one straight end (strip tongue).

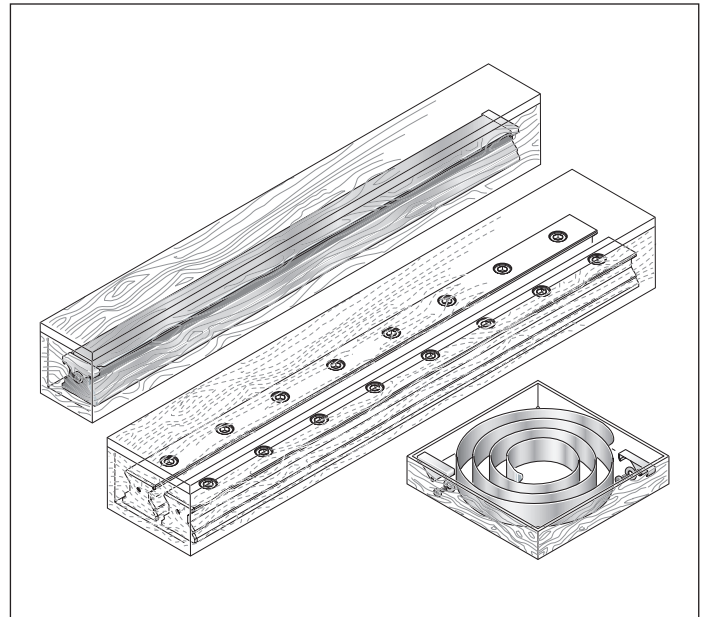

# General instructions for mounting

## Composite Standard roller guide rails

Matching sections of a composite roller guide rail are identified as such by a label on the packaging. All partial sections of the same rail have the same serial rail number. The numbering is marked on the top of the roller guide rail.

### Notes on gap width

For the maximum gap width at the joints, see table 1.

Size	Gap width ( $\mu\text{m}$ )
25	40
35	50
45	50
55	60
65	60
100	60
125	60

### Note on cover strip

For composite roller guide rails, a one-piece cover strip to cover the overall length L is supplied separately.

**Table 1**

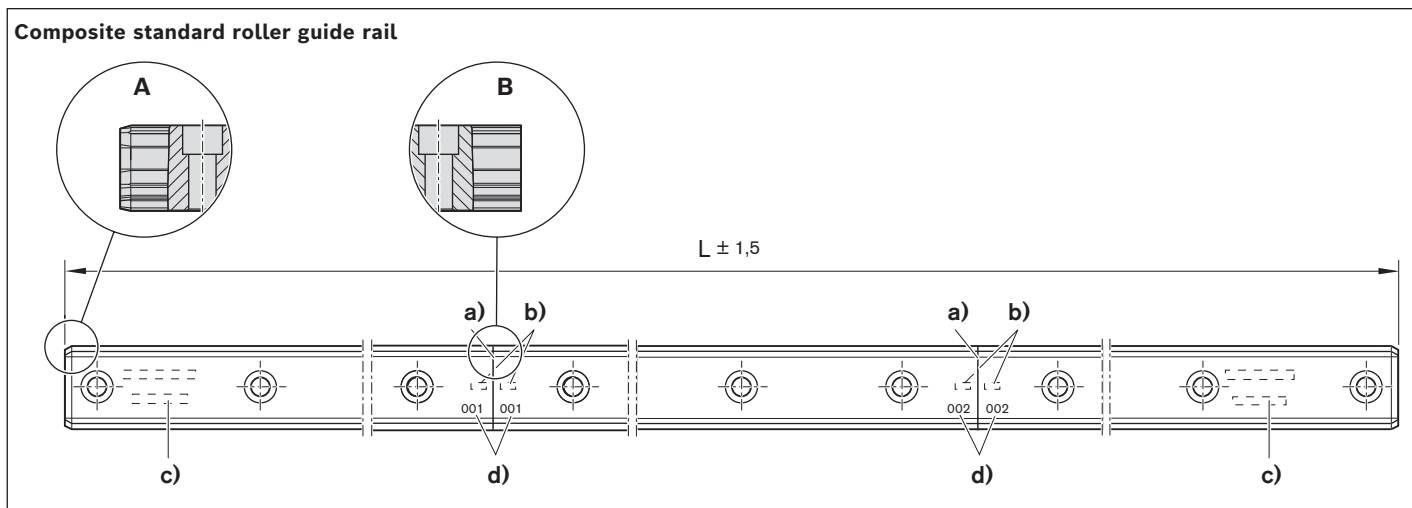

**A** Rail end with standard chamfer for sliding on the roller runner block

**B** Rail end with sharp-edged joint (without chamfer)

(Analog for heavy-duty roller guide rails)

**a)** Joint (sharp-edged, also in hard chrome plated roller guide rails)

**b)** Rail number

**c)** Full rail identification on first and last sections

**d)** Joint identification number

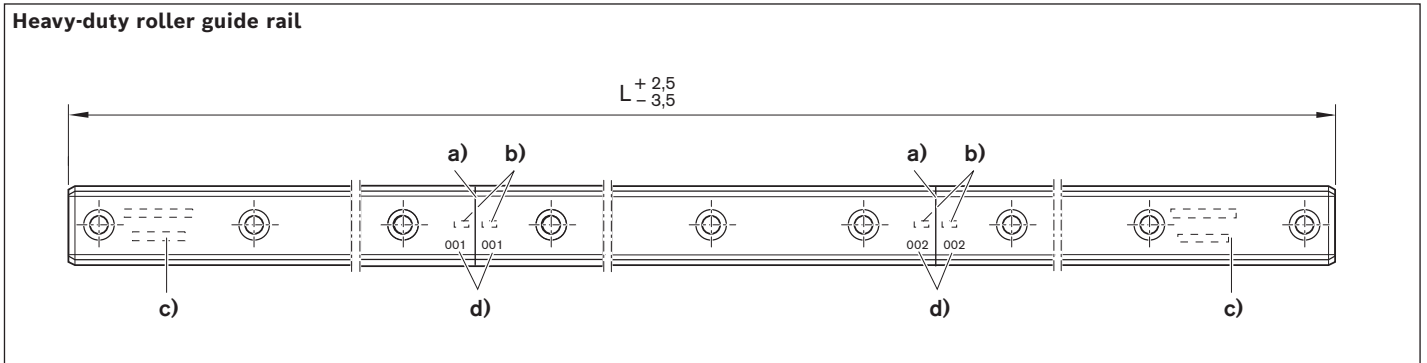

- a) Joint (sharp-edged, now also in hard chrome plated roller guide rails)
- b) Rail number
- c) Full rail identification on first and last sections
- d) Joint identification number

### Note on adjacent structures

Permissible bore position tolerances of the fastening bores for the adjacent structure, see table 2.

For composite roller guide rails, the actual tolerances of the individual sections may sum up. In such case, the fastening bore holes in the connecting structure may lie outside of the tolerances and a rework of the connecting structure may be required.

Size	Hole position tolerance (mm)
25 - 35	Ø 0.2
45 - 100	Ø 0.3
125	Ø 0.6

**Table 2**

## Composite roller guide rails with modular joint

Modular roller guide rails by Rexroth offer flexibility in machine concepts which require variable rail lengths with limitless travel speed.

### Benefits / special features

- ▶ Variable composite rail lengths may be realized flexibly with rail modules in various lengths.
- ▶ Rails may directly join each other.
- ▶ Due to the small chamfer (C) at the upper edge of the joint, a procedure with full travel speed is possible.
- ▶ Problem-free sliding on of the roller runner block via standard chamfer (A) on the end pieces
- ▶ Optimized storage and interchangeability

### To be observed/restriction

- ▶ Maximum number of sections: 8
- ▶ Problem-free sliding on of the roller runner block via standard chamfer (A) on the end pieces only

### Order

Only via direct inquiry.

### Note on Cover

The fastening bore holes can be closed with a one-piece cover strip with steel mounting hole plugs. Separately available upon request.

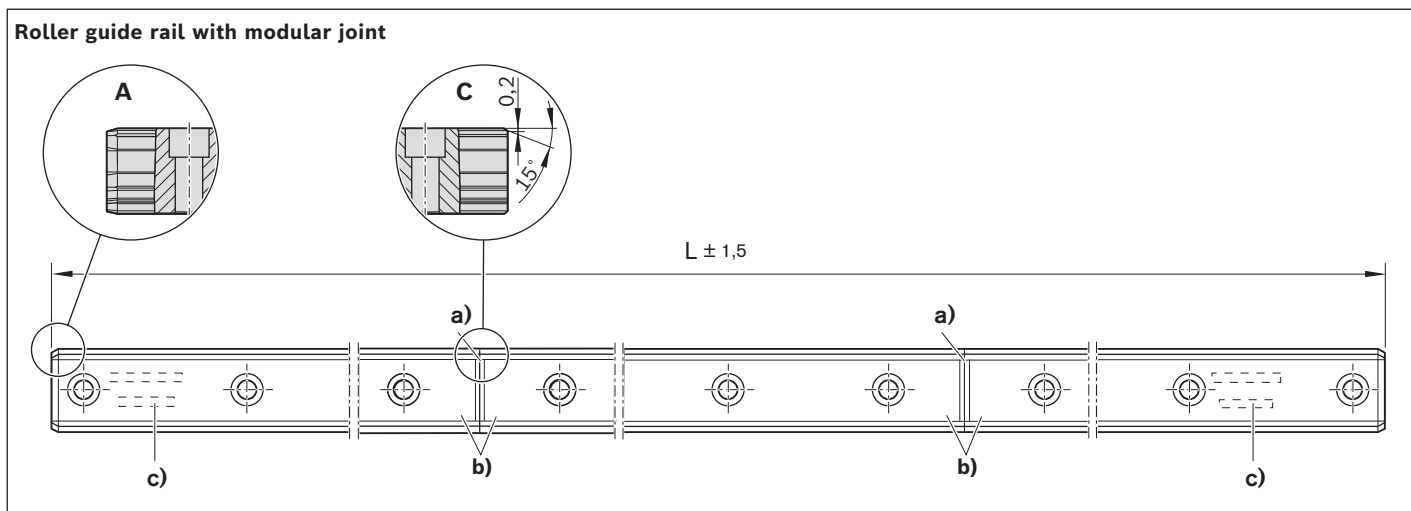

**A** Rail end with standard chamfer for sliding on the roller runner block

**C** Rail end with sharp joint and chamfer (C) on upper edge

**a)** Joint (sharp edges with chamfer (C) also with hard chrome plated roller guide rails)

**b)** No special markings required due to modularity

**c)** Full rail identification on first and last sections

## Composite roller guide rails with universal joint

Composite roller guide rails with universal joint by Rexroth offer flexibility with machine concepts, the variable rail lengths as well as interchangeability of roller runner blocks on all sections.

### Benefits / special features

- ▶ Variable composite rail lengths may be realized flexibly with rail modules in various lengths.
- ▶ Problem-free sliding on of the roller runner block via standard chamfer (A) on all sections and rail ends possible
- ▶ Optimized storage and interchangeability

### To be observed/restriction

- ▶ Maximum number of sections: 8
- ▶ Rails cannot directly join each other
  - Maximum travel speed up to 1 m/s
  - Increased contamination possible
- ▶ Minimum accuracy class SP

### Order

Only via direct inquiry.

### Note on Cover

The fastening bore holes can be closed with a one-piece cover strip with steel mounting hole plugs. Separately available upon request.

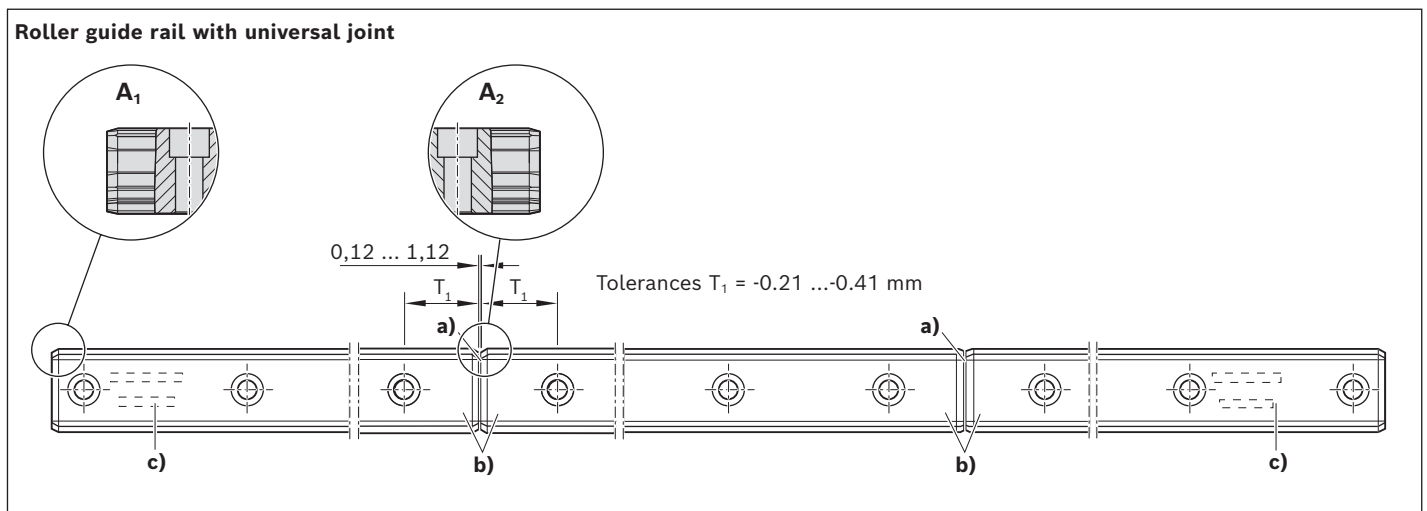

- A<sub>1</sub>** Rail end with standard chamfer for sliding on the roller runner block
- A<sub>2</sub>** Rail end with standard chamfer at joint (suitable for sliding on the roller runner block)

- a)** Joint (with standard chamfer (A) also with hard chrome plated roller guide rail)
- b)** No special markings required due to modularity
- c)** Full rail identification on first and last sections

### Adjusting shafts

The sections of composite roller guide rails can be aligned with the aid of adjusting shafts. For more detailed information see chapter "Accessories" and "Mounting Instructions for Roller Rail Systems".

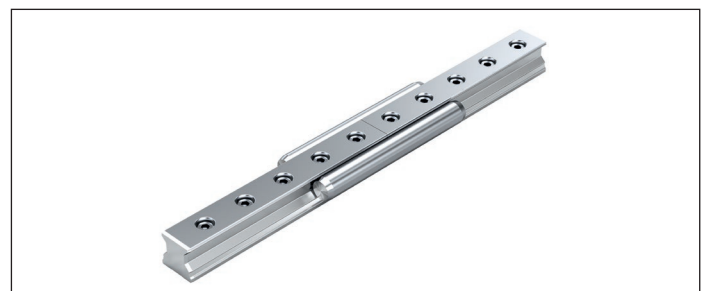

# General instructions for mounting

## Installation examples

### Roller guide rails

Each roller guide rail has ground reference surfaces on both sides. These are not marked, since each roller guide rail can be mounted to the left or the right of a reference edge (1) for lateral retention.

### Notes

- ▶ For roller guide rails without lateral retention during mounting, we recommend using a straightedge to make sure the rails are properly aligned and parallel (guideline values for permissible side load if no additional lateral retention is provided, see "Fastening").
- ▶ Use a Mounting Runner Block (see "General instruction for mounting").
- ▶ Install caps or a cover strip (see the relevant Mounting Instructions!):

- A** After mounting the roller guide rails, insert plastic caps for screw holes with plastic bolts flush with the rail top.
- B** To fit steel caps, always use the special mounting tool (see "Accessories"). Equalize any difference in height between roller guide rails! Only then can the roller runner blocks be mounted.
- C** For roller guide rails with cover strip, see "Notes on cover strip".

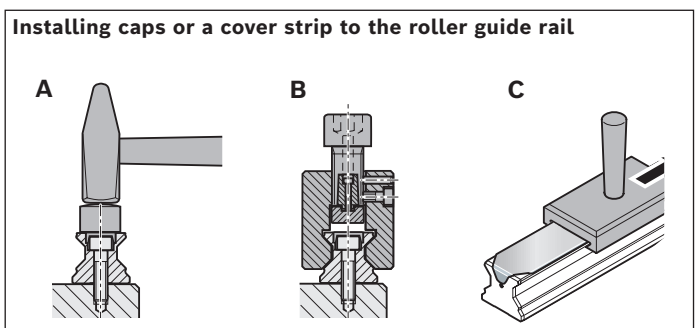
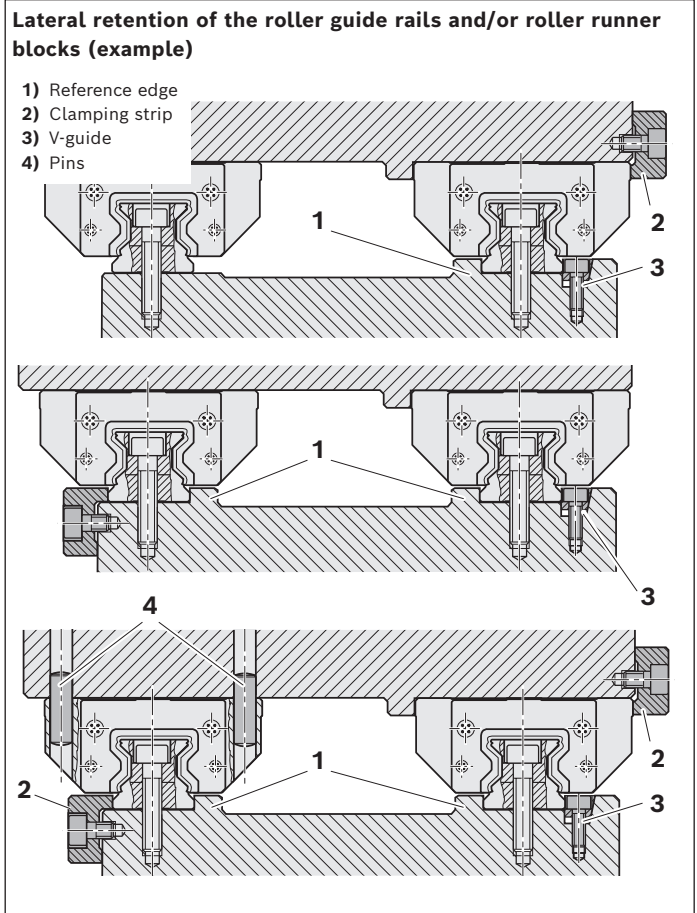

### Roller runner block

Standard and heavy-duty roller runner blocks have a polished reference edge (dimension  $V_1$  in the dimension drawings).

- ⚠ Always fit steel caps before pushing on the roller runner blocks! Before mounting the roller runner blocks, oil or grease the sealing lips of the roller runner blocks and the chamfer on the end face of the roller guide rail!
  - ▶ After sliding the roller runner block onto the rail, check that it moves easily.
  - ⚠ Then apply initial lubrication (see chapter "Lubrication")!
  - ▶ Detailed information on the mounting steps can be found in "Mounting Instructions for Roller Rail Systems".
- 
- ⚠ The roller runner block must remain on the transport lock (mounting device) until it is slid onto the roller guide rail! Otherwise, rolling elements (rollers) may be lost!
- 
- ⚠ Use the transport lock if the roller runner block is removed from the roller guide rail!  
When not installed on the rails, the roller runner blocks should always be kept on the transport lock!

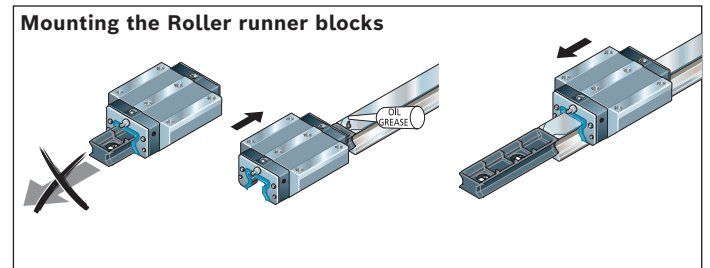

# Fastener

## Calculating screw connections

The screw connections in runner blocks and roller guide rails produce maximum static traction forces  $F_{0z \max}$ , maximum static torsional moments  $M_{0x \max}$  and maximum static side load  $F_{0y \max}$  without stop strips that the linear guide can transfer. This means, the maximum load on a profiled rail system is defined not only by the static load capacities  $C_0$  in accordance with ISO 14728 Part 2 and the static load moments  $M_{t0}$ , but also by the screw connections.

As a rule, roller runner blocks are fastened using 4 or 6 screws. Roller guide rails have one or two rows of screw connections in regular distances, whereby the screws located directly under the runner block are subject to the most stress. If the runner block and rail are fastened with screws in the same strength class, the bolting between the rail and the mounting base ( $O_3$ ) is critical to the maximum forces and moments that can be transferred.

The values in the table for strength class 8.8 are taken from DIN 637 (August 2013): Ball bearings – safety regulations for dimensioning and operation of Profiled Rail Systems with recirculating rolling elements. Screw connections with strength classes 10.9 and 12.9 are calculated based on the dimensions in the catalog (screw sizes, runner block lengths, clamping lengths, screw-in depths, bore diameters, rail separations of the rail bore holes, rail width, etc.).

Deviant screw connections are to be recalculated according to VDI 2230. The maximum static traction force and maximum static torsional moment of a Roller Rail System are the product of the sum of the axial forces on the rail screws within the flow of forces. However, for the maximum static side load, the sum of the clamping forces on the rail screws within the flow of forces is crucial.

Input values for calculation:

- Friction coefficient in the thread  $\mu_G = 0.125$
- Friction coefficient at the head surface  $\mu_K = 0.125$
- Friction coefficient in the joint  $\mu_T = 0.2$
- Tightening torque for torque wrench  $\alpha_A = 1.5$

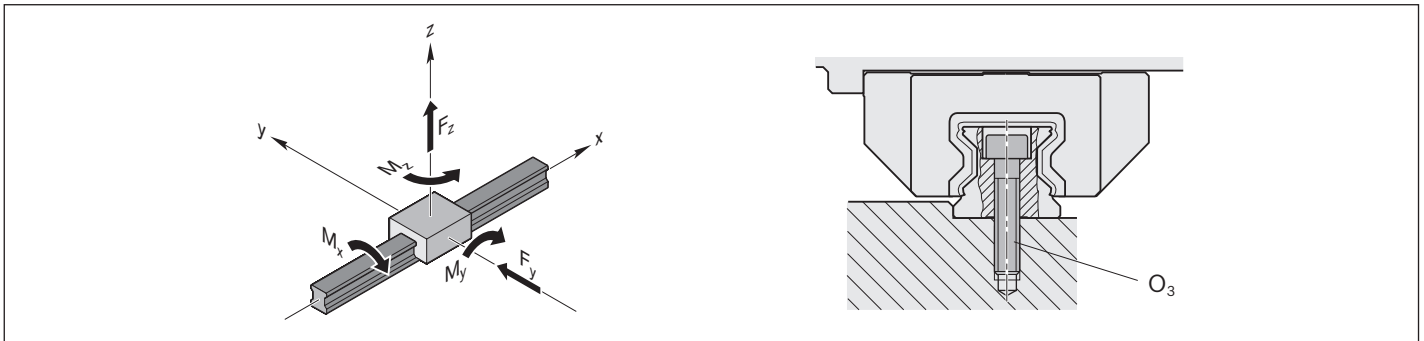

## Maximum static traction forces and torsional moments on Profiled Rail Systems (according to DIN 637)

The screw connections in a Profiled Rail System can only transfer a limited traction force  $F_z$  or a limited torsional moment  $M_x$ . If these limit values are exceeded, the guideway will be lifted off the adjacent structure or the screw connection will fail. The permissible values for a guideway are the product of the maximum possible axial force on a screw connection in the guide rail. Exceeding the indicated maximum static load is not permissible.

The given table values are guideline values for the permissible static traction force  $F_{0z \max}$  and torsional moments  $M_{0x \max}$  that are only applicable when the following conditions are met:

- Screw sizes, screw quantity and connecting dimensions as listed in the catalog
- Same fastening screw strength class for runner blocks and rails
- Steel adjacent structure
- Traction force  $F_z$  or torsional moment  $M_x$  are static
- Traction force  $F_z$  and torsional moment  $M_x$  do not occur simultaneously
- No interaction with side load  $F_y$  or longitudinal moment  $M_y / M_z$

If these conditions are not met, recalculate the screw connection in accordance with VDI 2230. If the applied loads are just below the limit values, Bosch Rexroth also recommends checking the screw connections.

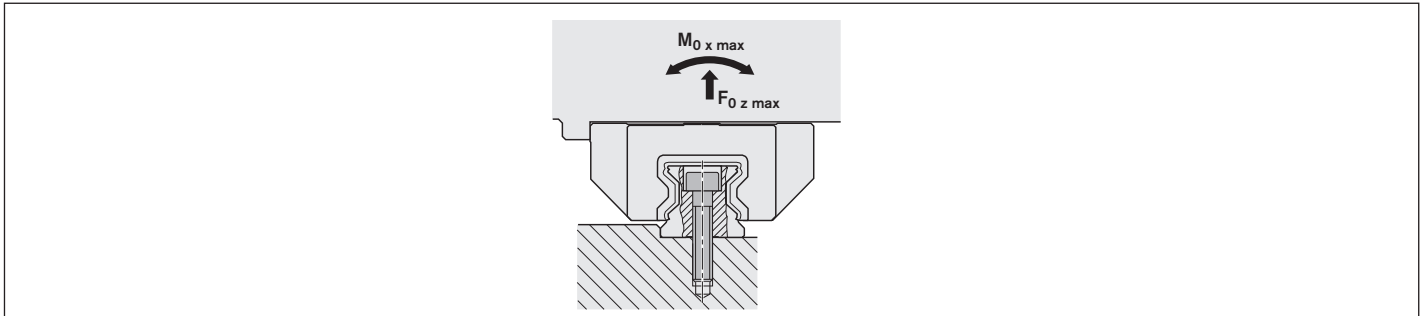
**Roller rail systems**

Size	Normal length		Long	
	$F_{0z \max}$ (N)	$M_{0x \max}$ (Nm)	$F_{0z \max}$ (N)	$M_{0x \max}$ (Nm)

**Strength class 8.8 (according to DIN 637)**

25	11700	120	15000	160
35	20900	330	27200	440
45	49100	1060	64900	1390
55	74800	1870	98500	2460
65	98700	2960	131000	3930
100	260000	12600	367000	17800
125	455000	27300	640000	38400

**Strength class 10.9 (calculated with Rexroth Roller Rail System dimensions)**

25	18500	190	23800	250
35	32700	520	42500	680
45	69900	1500	92300	1990
55	113000	2820	149000	3720
65	149000	4470	198000	5940
100	376000	18200	531000	25700
125	654000	39300	922000	55300

**Strength class 12.9 (calculated with Rexroth Roller Rail System dimensions)**

25	22200	230	28500	300
35	39000	620	50700	810
45	69900	1500	92300	1990
55	113000	2820	149000	3720
65	155000	4650	206000	6170
100	399000	19300	563000	27300
125	664000	39900	935000	56100

## Fastener

### Maximum static side load without stop strips (according to DIN 637)

For a secure structure, Rexroth recommends using stop strips on the Runner Block and Guide Rail. If stop strips are not used on the runner block or the rail, then if a load is applied in the transverse direction the guideway may slip. The clamping force of the screw connection is too low as soon as the side loads in the table are exceeded.





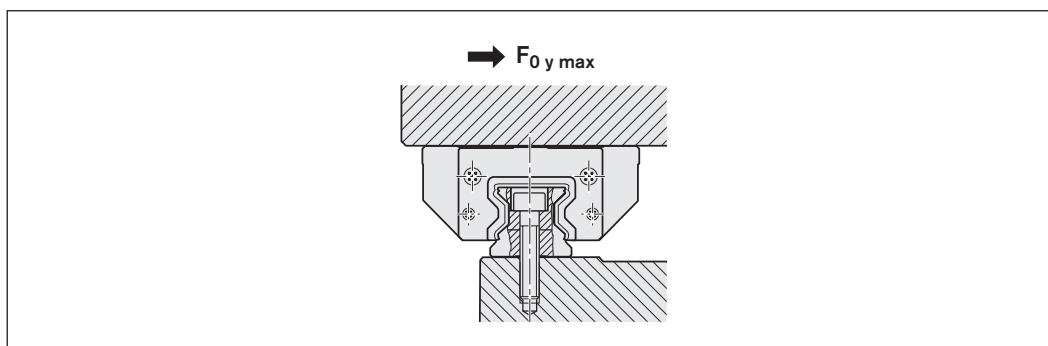

The table values are guideline values for the permissible static side loads  $F_{0y \max}$  that are only applicable when the following conditions are met:

- Screw sizes, screw quantity and connecting dimensions as listed in the catalog
- Same fastening screw strength class for runner blocks and rails
- Steel adjacent structure
- No interaction with traction force  $F_z$ , torsional moments  $M_x$  or longitudinal moments  $M_y / M_z$

If these conditions are not met, recalculate the screw connection in accordance with VDI 2230. If the applied loads are just below the limit values, Bosch Rexroth also recommends checking the screw connections.





### Roller rail systems

Size	Strength class					
	8.8		10.9		12.9	
	Normal length	Long	Normal length	Long	Normal length	Long
						
	$F_{0y \max}$ (N)	$F_{0y \max}$ (N)	$F_{0y \max}$ (N)	$F_{0y \max}$ (N)	$F_{0y \max}$ (N)	$F_{0y \max}$ (N)
<b>25</b>	1910	2450	3030	3880	3620	4650
<b>35</b>	3400	4430	5320	6930	6340	8260
<b>45</b>	7940	10500	10300	13600	10300	13600
<b>55</b>	12100	16000	16900	22200	16900	22200
<b>65</b>	16000	21300	23100	30700	23100	30700
<b>100</b>	38400	54200	55500	78300	58800	83100
<b>125</b>	68100	95900	98000	138000	99500	140000



## Tightening torques for Profiled Rail Systems (as per DIN 637)

The tightening torques for screw strength class 8.8 correspond to DIN 637. The tightening torques for screw strength classes 10.9 and 12.9 were calculated for the dimensions of a Rexroth Roller Rail System.

### Runner block

Size	FKS, FNS, FLS, FKN, FNN, BNS, CNS									SKS, SNS, SLS, SKN, SNN, SNH, SLH			
	for bolting from above					for bolting from below				for bolting from above			
	O4					O1&O2				O5			
		8.8	10.9	12.9			8.8	10.9	12.9		8.8	10.9	12.9
$M_A$ [Nm]					$M_A$ [Nm]				$M_A$ [Nm]				
25	M8	26	38	44	M6	8.4	8.4	8.4	M6	11	16	18	
35	M10	51	74	87	M8	27	28	28	M8	26	38	44	
45	M12	87	130	130	M10	52	66	66	M10	51	74	87	
55	M14	140	200	220	M12	81	81	81	M12	87	130	130	
65	M16	210	310	340	M14	140	150	150	M16	210	310	340	
100	M20	430	610	650	M16	150	150	150					
125	M27	1090	1480	1480	M24	760	850	850					

### Guide rail

Size	for bolting from above				for bolting from below			
	O3				O6			
		8.8	10.9	12.9		8.8	10.9	12.9
	$M_A$ [Nm]				$M_A$ [Nm]			
25	M6	11	16	18	M6	11	16	18
35	M8	26	38	44	M8	26	38	44
45	M12	88	110	110	M12	87	130	140
55	M14	140	190	190	M14	140	200	230
65	M16	220	300	300	M16	210	310	360
100	M24	740	1060	1120				
125	M30	1480	2110	2140				

# Fastener

## Reference edges and corner radii

### Combination examples

The combinations shown here are examples. Basically, any roller runner block may be combined with any of the roller guide rail types offered.

### Mounting and lubrication

For details of roller runner block and roller guide rail mounting, see "General instruction for mounting".

For initial and in-service lubrication, see chapter "Lubrication".

Detailed information on the mounting steps can be found in "Mounting Instructions for Roller Rail Systems".

## Standard Roller Rail Systems

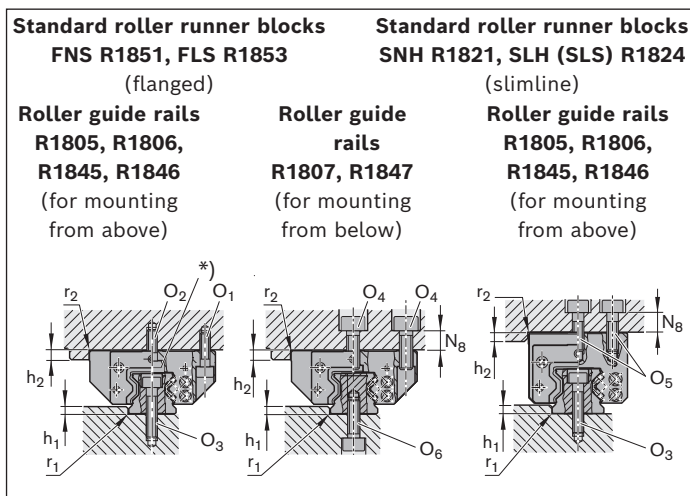

\*) Recess on request

Size	Dimensions (mm)					
	$h_{1 \min}$	$h_{1 \max}^{1)}$	$h_2$	$N_8$	$r_{1 \max}$	$r_{2 \max}$
25	3.0	4.5	5	10	0.8	0.8
35	3.5	5.0	6	13	0.8	0.8
45	4.5	7.0	8	14	0.8	0.8
55	7.0	9.0	10	20	1.2	1.0
65	7.0	9.0	14	22	1.2	1.0

1) When using clamping and braking units, please take account of the values  $H_1$ .

## Fastening screws

**⚠** Always make sure the screws are secure where there are high screw loads!

Size	Screw sizes					
	Roller runner block				Roller guide rail	
	$O_1$	$O_2^{1)}$	$O_4^{1) 2)}$	$O_5$	$O_3$	$O_6$
	ISO 4762 4 pieces	DIN 6912 2 pieces	ISO 4762 6 pieces	ISO 4762 6 pieces	ISO 4762	ISO 4762
25	M6×20	M6×16	M8×20	M6×18	M6×30	M6×20
35	M8×25	M8×20	M10×25	M8×25	M8×35	M8×25
45	M10×30	M10×25	M12×30	M10×30	M12×45	M12×30
55	M12×40	M12×30	M14×40	M12×35	M14×50	M14×40
65	M14×45	M14×35	M16×45	M16×40	M16×60	M16×45

- 1) When fastening the Roller runner block with 6 screws: Tighten the middle screws ( $O_2$ ,  $O_4$ ) to a tightening torque for strength class 8.8
- 2) When fastening the roller runner block from above with only 4  $O_4$  screws: Permissible side load 1/3 lower and lower rigidity

## Locating pins

⚠ If the guideline values for permissible side loads are exceeded, the roller runner block must be additionally fixed!

### Possible pin types

- ▶ Tapered pin (hardened) or
- ▶ Straight pin DIN ISO 8734

### Notes

Rough-drilled holes made for production reasons may exist at the recommended pin hole positions on the roller runner block centerline ( $\varnothing < S_{10}$ ). They are suitable for drilling out.

If the locating pins have to be inserted in another position, dimension  $E_2$  must not be exceeded in the longitudinal direction (for dimension  $E_2$ , see the dimension tables for the individual roller runner block types).  
Comply with dimensions  $E_1$  and  $E_4$ !

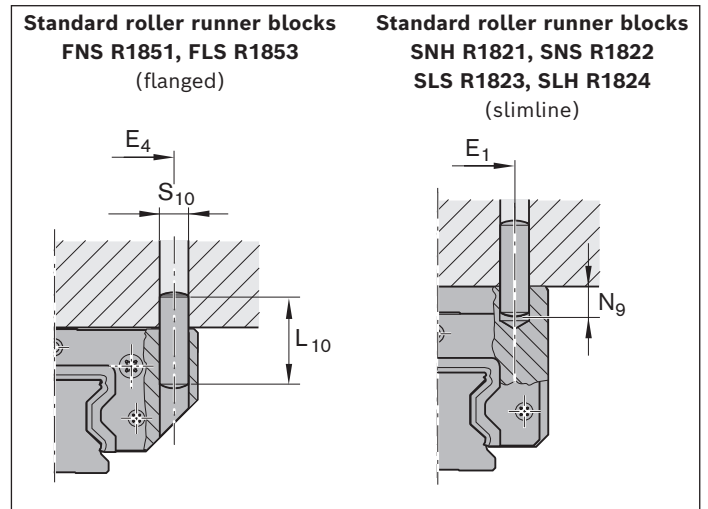

Size	Dimensions (mm)				
	$E_1$	$E_4$	$L_{10}^{1)}$	$N_{9 \max}$	$S_{10}^{1)}$
<b>25</b>	35	55	32	9	6
<b>35</b>	50	80	40	13	8
<b>45</b>	60	98	50	18	10
<b>55</b>	75	114	60	19	12
<b>65</b>	76	140	60	22	14

1) Tapered pin (hardened) or straight pin (ISO 8734)

# Fastener

## Reference edges and corner radii

### Mounting and lubrication

For details of roller runner block and roller guide rail mounting, see "General instruction for mounting".

To facilitate the mounting of heavy-duty roller runner blocks on the rail, a mounting aid is available on request (see chapter "Accessories").

For initial and in-service lubrication, see chapter "Lubrication".

Detailed information on the mounting steps can be found in "Mounting Instructions for Roller Rail Systems".

## Heavy-duty roller rail system

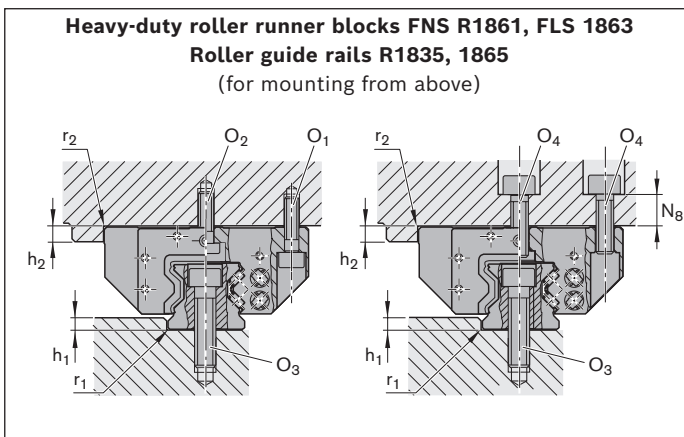

Size	Dimensions (mm)					
	$h_{1 \min}$	$h_{1 \max}$	$h_2$	$N_8$	$r_{1 \max}$	$r_{2 \max}$
<b>100</b>	10	14	18	30	1.8	1.3
<b>125</b>	15	20	23	40	1.8	1.8

## Fastening screws

**⚠** Always make sure the screws are secure where there are high screw loads!

Size	Screw sizes			
	Roller runner block			Roller guide rail
	$O_1$	$O_2^{1)}$	$O_4^{1) 2)}$	$O_3$
	ISO 4762	DIN 6912	ISO 4762	ISO 4762
	6 pieces	3 pieces	9 pieces	
<b>100</b>	M16×60	M16×55	M20×60	M24×100
<b>125</b>	M24×85	M24×70	M27×80	M30×120

- 1) When fastening the roller runner block with 9 screws: Tighten the centerline screws  $O_2$  or  $O_4$  along the roller guide rail with the tightening torque for strength class 8.8.
- 2) When fastening the roller runner block from above with only 6  $O_4$  screws: Permissible side load 1/3 lower and lower rigidity



## Note on lubrication

- ▶ The service life of the Roller Rail Systems crucially depends on the lubrication. For this purpose, the documentation, especially the chapter Lubrication, must be read and understood completely.
  - ▶ The operator is responsible for the selection and adequate supply of an appropriate lubricant to the Roller Rail System. These notes do not exempt the operator from the individual examination of the conformity and suitability of the lubricant for its application.
  - ▶ For recommended lubricants, see chapter "Notes on Dynalub".
  - ▶ Rexroth Roller Rail System are delivered filled with an anti-corrosion agent (sufficient for mounting). Immediately after mounting the roller runner blocks (before commissioning), make sure the system has sufficient initial lubrication (basic lubrication). All roller runner blocks are designed for both grease lubrication and for oil lubrication.
- ⚠ To safeguard the supply of lubricant, the lube fittings from the chapter "Accessories" must be used. When using other lube fittings it must be ensured that they are identical to Rexroth lube fittings (M6x8).
- ⚠ If using a progressive lubrication system, with grease lubrication, please pay attention to the minimum dosing amount for relubrication stated in table 5.
- ⚠ We recommend carrying out initial lubrication separately using a grease gun before connecting to the central lubrication system.
- If using a central lubrication system, you must make sure that all the pipes and elements are filled with lubricant and do not contain any air pockets until they are connected to the consumer (roller runner block).
- The number of pulses results from the partial amounts and the piston distributor size
- ▶ With fluid grease lubrication according to table 5
  - ▶ With oil lubrication according to table 8
- ⚠ The seals on the roller runner block must be oiled or lubricated with the respective lubricant before mounting.
- ⚠ If you use different lubricants than the ones specified, relubrication intervals may be shorter and performance may decrease with short stroke and load ratio; in addition, chemical interactions can take place between the plastics, lubricants and preservative agents. Single-line central lubrication systems also need to be able to pump these lubricants.
- ⚠ Lubricant reservoirs should contain an agitator to ensure the lubricant can flow (avoids hardening in the reservoir).
- ⚠ Do not use lubricants with solid particles (e.g. graphite or MoS<sub>2</sub>)!
- ⚠ In the case of relubrication, it is not possible to change from grease to oil lubrication.
- ⚠ If environmental factors such as contamination, vibrations, impact loads, etc. are present, we recommend shorter relubrication intervals. Even under normal operating conditions, relubrication is required every 2 years due to grease aging.
- ▶ If your application involves more demanding environmental requirements (such as clean room, vacuum, food industry applications, increased exposure to fluids or aggressive media, extreme temperatures), please consult us. Each application must be considered on its own merits in order to choose the most appropriate lubricant. Be sure to have all the information concerning your application at hand when contacting us. Pay attention to the chapter "Maintenance".
  - ▶ Rexroth recommends piston distributors by SKF. These should be installed as close as possible to the lube ports of the Roller runner blocks. Long lines and small line diameters should be avoided, and the lines should be laid on an upward slant. Install the lines at a gradient.
  - ▶ Refer to the chapter "Accessories for Roller runner blocks" for a selection of possible lube ports (also contact the manufacturer of your lubrication system considering this issue).
  - ▶ If other consumers are connected to the single-line lubrication system, the weakest link in this chain determines the lubrication cycle.

**Note on the use of Roller Rail Systems in tool machines**

Roller rail systems in tool machines are usually operated using coolant/lubricant and lubricants. The user alone is responsible for selecting suitable metalworking fluids.

- ▲ An unfavorable selection of coolant/lubricant may lead to damage to the roller rail system. We recommend getting in touch with the manufacturer of the coolant/lubricant. Bosch Rexroth accepts no liability. Lubricant and metalworking fluids must be coordinated.
- ▲ When applying metalworking fluids at the start or after a relatively long standstill, carry out 2 to 5 lubrication pulses in succession. When the system is in operation, the guideline value is 3 to 4 pulses per hour, irrespective of the distance traveled. If possible, carry out lubrication in one lubricating stroke. Carry out cleaning cycles (see "Maintenance").

**Note on load ratio**

The load ratio  $F/C$  is the quotient of the equivalent dynamic load on bearing  $F$  (making allowance for the preload  $C$ ) divided by the dynamic load capacity  $C$  (see "General Technical Data and Calculations").

**Notes on Dynalub**

(Approved for EU countries only; not approved outside of the EU)

- ▲ Pay attention to the allocation of the roller rail system.

Under conventional environmental conditions, this short-fibred, homogeneous grease is ideally suited for the lubrication of linear elements:

- ▶ With loads up to 50 %  $C$
- ▶ With short-stroke applications  $> 1$  mm
- ▶ For the permissible travel speed range of Roller Rail Systems

The product and material safety data sheets can be found on our website at: [www.boschrexroth.com](http://www.boschrexroth.com).

**Dynalub 510****Grease lubricant**

Features:

- ▶ Lithium-based, high-performance grease of grade NLGI 2 according to DIN 51818 (KP2K-20 according to DIN 51825)
- ▶ Good water resistance
- ▶ Corrosion protection
- ▶ Temperature range:  $-20$  to  $+80$  °C

Material numbers for Dynalub 510:

- ▶ R3416 037 00 (cartridge 400 g)
- ▶ R3416 035 00 (hobcock 25 kg)

**Alternative greases:**

- ▶ Castrol Tribol GR100-2 PD<sup>\*)</sup> or Elkalub GLS 135/N2<sup>\*)</sup>

**Dynalub 520****Liquid grease**

Features:

- ▶ Lithium-based, high-performance grease of grade NLGI 00 according to DIN 51818 (GP00K-20 according to DIN 51826)
- ▶ Good water resistance
- ▶ Corrosion protection
- ▶ Temperature range:  $-20$  to  $+80$  °C

Material numbers for Dynalub 520:

- ▶ R3416 043 00 (cartridge 400 g)
- ▶ R3416 042 00 (bucket 5 kg)

**Alternative greases:**

- ▶ Castrol Tribol GR100-00 PD00<sup>\*)</sup> or Elkalub GLS 135/N00<sup>\*)</sup>

\*) No liability is accepted for changes to the product properties of these lubricants.

**Notes on lubricant oil**

We recommend **Shell Tonna S3 M 220** or similar products with the following properties:

- ▶ Special demulsifying oil CLP or CGLP as per DIN 51517-3 for machine bed tracks and tool guides
- ▶ A blend of highly refined mineral base oils and additives
- ▶ Can be used even when mixed with significant quantities of metalworking fluids

# Lubrication RSHP

Grease lubrication with grease guns or progressive lubrication systems

⚠ See chapter "Note on lubrication".

## Grease lubricant

We recommend using **Dynalub 510**. For further information, please refer to chapter "Note on lubrication".

## Lube connection, end cap

L = Left

R = Right

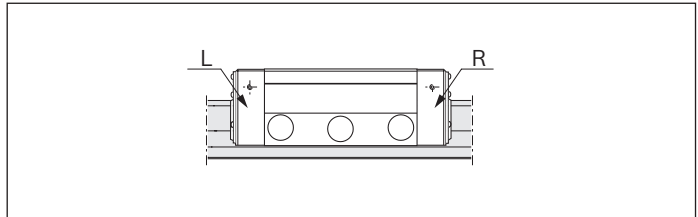

## Initial lubrication of the roller runner block (basic lubrication)

### Stroke $\geq 2 \cdot$ roller runner block $B_1$ (normal stroke)

► One lube connection per roller runner block, attach optionally on the left or right end cap and lubricate!

The initial lubrication is done three times with the partial amount according to table 1:

1. Pre-lubricate the roller runner blocks with an initial partial amount according to table 1 by slowly applying pressure to the grease gun.
2. Slide the roller runner block back and forth by at least three times the runner block length for three full cycles.
3. Repeat steps 1 and 2 twice more.
4. Check whether a film of grease is visible on the roller guide rail.

### Stroke $< 2 \cdot$ roller runner block Length $B_1$ (short stroke)

► Two lube connections per roller runner block, attach one connection optionally on the left and right end cap and lubricate!

The initial lubrication is done three times for each connection with the partial amount according to table 1:

1. Pre-lubricate the roller runner blocks for each connection with an initial partial amount according to table 1 by slowly applying pressure to the grease gun.
2. Slide the roller runner block back and forth by at least three times the runner block length for three full cycles.
3. Repeat steps 1 and 2 twice more.
4. Check whether a film of grease is visible on the roller guide rail.

Size	Initial lubrication amount		
	Normal stroke Partial amount (cm <sup>3</sup> )	Short stroke Partial amount per connection (cm <sup>3</sup> )	
		L	R
25	0.8 (3×) <sup>1)</sup>	0.8 (3×) <sup>1)</sup>	0.8 (3×) <sup>1)</sup>
35	0.9 (3×)	0.9 (3×)	0.9 (3×)
45	1.0 (3×)	1.0 (3×)	1.0 (3×)
55	2.5 (3×)	2.5 (3×)	2.5 (3×)
65	2.7 (3×)	2.7 (3×)	2.7 (3×)

**Table 1**

1) When using the lubrication plate (see "Lubrication plate for size 25"), the initial lubrication quantity should be increased by at least 0.24 cm<sup>3</sup>.

## Relubrication of Roller runner blocks

### Stroke $\geq 2 \cdot$ roller runner block $B_1$ (normal stroke)

- ▶ Once the relubrication interval according to Diagram 1 has been reached, relubricate the amount stated in table 2.

### Stroke $< 2 \cdot$ roller runner block Length $B_1$ (short stroke)

- ▶ Once the relubrication interval according to Diagram 1 has been reached, relubricate the amount stated in table 2 for each lube connection.
- ▶ For each lubrication cycle, the roller runner block should be moved with a lubricating stroke of  $3 \cdot$  roller runner block length  $B_1$ ; as minimum lubricating stroke, however, roller runner block length  $B_1$  should be moved.

### Calculating the lubrication cycle

$f_{KSS} = 1$  (no coolant/lubricant charge)

$f_{KSS} = 5$  (with coolant/lubricant charge)

### Load-dependent relubrication intervals

#### This applies to the following conditions:

- ▶ Maximum speed:  $v_{max} = 4$  m/s
- ▶ No media pressurization
- ▶ Standard seals
- ▶ Ambient temperature:  $T = 10 - 40$  °C

#### Key

$s$  = Lubrication interval as travel distance (km)  
 $C$  = Dynamic load capacity (N)  
 $F_m/C$  = Dynamic equivalent load on bearing (N)  
 $S_T$  = Lubrication cycle for the application  
 $f_{KSS}$  = Correction factor for coolant/lubricant

Size	Relubrication quantity		
	Normal stroke (cm <sup>3</sup> )	Short stroke per connection (cm <sup>3</sup> )	
		L	R
25	0.8	0.8	0.8
35	0.9	0.9	0.9
45	1.0	1.0	1.0
55	2.5	2.5	2.5
65	2.7	2.7	2.7

**Table 2**

$$S_T = s \cdot \frac{1}{f_{KSS}}$$

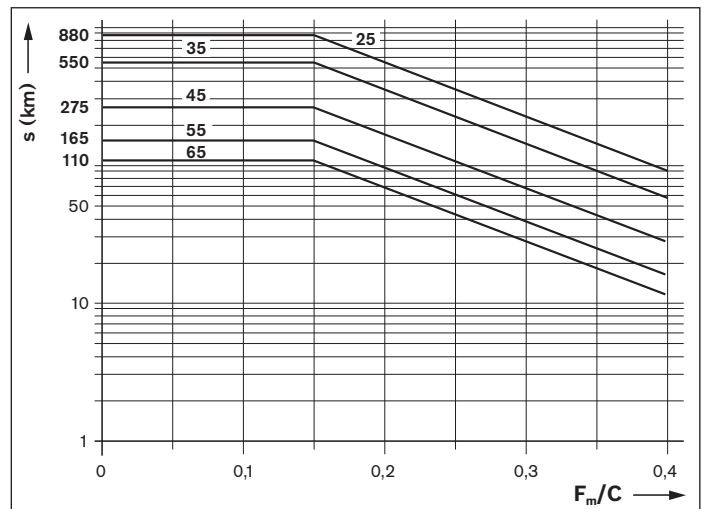

**Fig. 1: Relubrication interval**

# Lubrication RSHP

Liquid grease lubrication (NLGI 00) with central lubrication system via piston distributor

⚠ See chapter "Note on lubrication".

## Liquid grease

We recommend using **Dynalub 520**. For further information, please refer to chapter "Note on lubrication".

## Lube connection, end cap

L = Left

R = Right

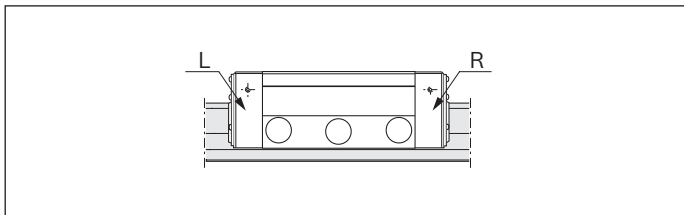

## Initial lubrication of the roller runner block (basic lubrication)

We recommend carrying out initial lubrication separately using a grease gun before connecting to the central lubrication system. If the initial lubrication is nevertheless carried out via the central lubrication system, care must be taken to ensure that all lines and piston distributors are filled. The number of pulses is then obtained from the partial amounts according to table 3 and the piston distributor size according to table 5.

### Stroke $\geq 2$ · roller runner block $B_1$ (normal stroke)

► One lube connection per roller runner block, attach optionally on the left or right end cap and lubricate!

The initial lubrication is done three times with the partial amount according to table 3:

1. Pre-lubricate the roller runner blocks with an initial partial amount according to table 3 by slowly applying pressure to the grease gun.
2. Slide the roller runner block back and forth by at least three times the runner block length for three full cycles.
3. Repeat steps 1 and 2 twice more.
4. Check whether a film of grease is visible on the roller guide rail.

### Stroke $< 2$ · roller runner block Length $B_1$ (short stroke)

► Two lube connections per roller runner block, attach one connection optionally on the left and right end cap and lubricate!

The initial lubrication is done three times for each connection with the partial amount according to table 3:

1. Pre-lubricate the roller runner blocks for each connection with an initial partial amount according to table 3 by slowly applying pressure to the grease gun.
2. Slide the roller runner block back and forth by at least three times the runner block length for three full cycles.
3. Repeat steps 1 and 2 twice more.
4. Check whether a film of grease is visible on the roller guide rail.

Size	Initial lubrication amount		
	Normal stroke Partial amount (cm <sup>3</sup> )	Short stroke Partial amount per connection (cm <sup>3</sup> )	
		L	R
25	0.8 (3×) <sup>1)</sup>	0.8 (3×) <sup>1)</sup>	0.8 (3×) <sup>1)</sup>
35	0.9 (3×)	0.9 (3×)	0.9 (3×)
45	1.0 (3×)	1.0 (3×)	1.0 (3×)
55	1.4 (3×)	1.4 (3×)	1.4 (3×)
65	2.7 (3×)	2.7 (3×)	2.7 (3×)

**Table 3**

- 1) When using the lubrication plate (see "Lubrication plate for size 25"), the initial lubrication quantity should be increased by at least 0.24 cm<sup>3</sup>.

## Relubrication of Roller runner blocks

### Stroke $\geq 2 \cdot$ roller runner block $B_1$ (normal stroke)

- ▶ Apply the minimum quantity according to table 4 at the lube connection until the relubrication interval (figure 2) has been reached.

### Stroke $< 2 \cdot$ roller runner block Length $B_1$ (short stroke)

- ▶ Apply the minimum quantity according to table 4 for each lube connection until the relubrication interval (figure 2) has been reached. The number of pulses required for this purpose and the lubrication cycle are to be determined in a similar way as the relubrication (normal stroke).
- ▶ For each lubrication cycle, the roller runner block should be moved with a lubricating stroke of  $3 \cdot$  roller runner block length  $B_1$ ; as minimum lubricating stroke, however, roller runner block length  $B_1$  should be moved.

**Notes:** The number of pulses that is needed for this is the integer quotient of the minimum relubrication amount according to table 4 and the selected piston distributor size according to table 5. The smallest permissible piston distributor size does not depend on the installation position. The lubrication cycle according to formula 1 is the result from the division of the relubrication interval (according to figure 2) by the determined number of pulses (cf. sizing example).

### Calculating the lubrication cycle

$f_{KSS} = 1$  (no coolant/lubricant charge)

$f_{KSS} = 5$  (with coolant/lubricant charge)

### Load-dependent relubrication intervals

#### This applies to the following conditions:

- ▶ Maximum speed:  $v_{max} = 4$  m/s
- ▶ No media pressurization
- ▶ Standard seals
- ▶ Ambient temperature:  $T = 10 - 40$  °C

#### Key

$n_i$	= Number of pulses	(-)
$V_{Fett}$	= Relubrication amount according to table 4	( $cm^3$ )
$K_v$	= Piston distributor size according to table 5	( $cm^3$ )
$s_T$	= Lubrication cycle	(km)
$s$	= Relubrication interval according to figure 2	(km)
$C$	= Dynamic load capacity	(N)
$F_m/C$	= Dynamic equivalent load on bearing	(N)
$S_T$	= Lubrication cycle for the application	
$f_{KSS}$	= Correction factor for coolant/lubricant	

Size	Relubrication quantity		
	Normal stroke ( $cm^3$ )	Short stroke per connection ( $cm^3$ )	
		L	R
25	0.8	0.8	0.8
35	0.9	0.9	0.9
45	1.0	1.0	1.0
55	1.4	1.4	1.4
65	2.7	2.7	2.7

**Table 4**

$$n_i = V_{Fett} / K_v$$

$$S_T = s \cdot \frac{1}{f_{KSS}} \cdot \frac{1}{n_i}$$

**Formulas 1**

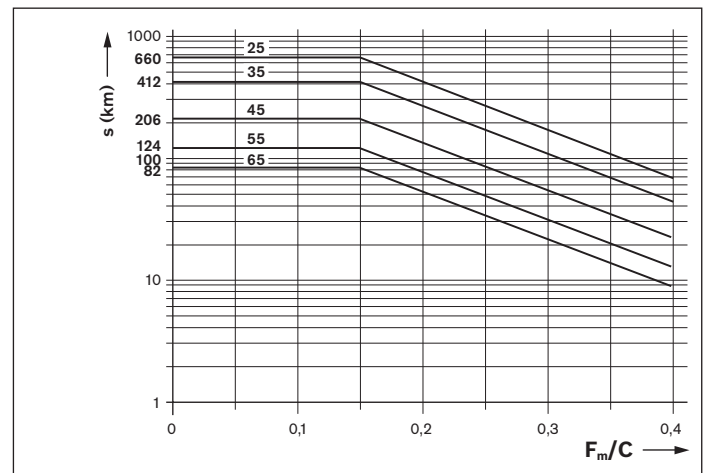

**Fig. 2: Relubrication interval**

Material number Roller runner block	Smallest permissible piston distributor size ( $\hat{=}$ Minimum pulse quantity) for each connection ( $cm^3$ )					
	Size	25	35	45	55	65
R18 ... 2X		0.06	0.1	0.1	0.1	0.2

**Table 5**

Liquid grease lubrication (NLGI 00) with central lubrication system via piston distributor  
(continued)**Calculation example:**

Given data:

<b>Roller runner block</b>	1851 323 2X
<b>Dynamic load capacity C</b>	61000 N
<b>Dynamically equivalent load on bearing</b>	18300 N
<b>Stroke</b>	500 mm
<b>Average speed <math>v_m</math></b>	1.0 m/s
<b>Temperature T</b>	20 – 30 °C
<b>Installation position</b>	Horizontal
<b>Lubrication</b>	Introduction lubrication system for all axes with liquid grease Dynalub 520
<b>Exposure to contaminants</b>	no exposure to media, chips, dust

Calculation of the relubrication quantity:

<b>Normal stroke or short stroke</b>	Normal stroke	Stroke $\geq 2 \cdot$ roller runner block length B1 500 mm $\geq 2 \times 79.6$ mm 500 mm $\geq 159.2$ mm i.e. normal stroke applies
<b>Initial lubrication amount</b>	0.90 cm <sup>3</sup> (3×)	according to table 3
<b>Relubrication quantity</b>	$V_{FettSe} = 0.90$ cm <sup>3</sup>	according to table 4
<b>Permissible piston distributor size</b>	$K_v = 0.1$ cm <sup>3</sup>	according to table 5
<b>Number of pulses</b>	$n_i = V_{Fett} / KV = 0.90$ cm <sup>3</sup> / 0.1 = 9	according to formulas 1
<b>Load ratio</b>	$F/C = 18300$ N/61000 N = 0.30	
<b>Relubrication interval</b>	s = 100 km	according to image 2
<b>Lubrication cycle</b>	$s_T = s / n_i = 100$ Km / 9 = 11.11 km	according to formulas 1
<b>Exposure to contaminants</b>	$S_T = s \cdot \frac{1}{1} \cdot \frac{1}{9}$	no exposure to media: Shavings, dust ...

Result:

A minimum quantity of 0.1 cm<sup>3</sup> of Dynalub 520 is to be supplied to the roller runner block every 11.11 km.



# Lubrication RSHP

## Oil lubrication with single-line piston distributor systems

⚠ See chapter "Note on lubrication".

### Lubricant oil

We recommend **Shell Tonna S3 M220**. For further information, please refer to chapter "Note on lubrication".

### Lube connection, end cap

L = Left

R = Right

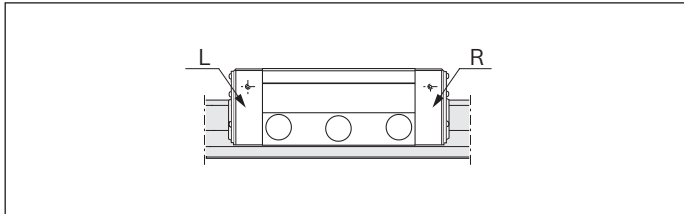

### Initial lubrication of the roller runner block (basic lubrication)

We recommend carrying out initial lubrication separately using a manual grease gun before connecting to the central lubrication system. If the initial lubrication is implemented via the central lubrication system, it is to be ensured that all lines and piston distributors are filled.

#### Stroke $\geq 2$ · roller runner block $B_1$ (normal stroke)

► One lube connection per roller runner block, attach optionally on the left or right end cap and lubricate!

The initial lubrication is done two times with the partial amount according to table 6:

1. Oil the roller runner block with the initial partial amount according to table 6.
2. Slide the roller runner block back and forth by at least three times the runner block length for three full cycles.
3. Repeat steps 1 and 2 once again.
4. Check whether a film of grease is visible on the roller guide rail.

#### Stroke $< 2$ · roller runner block Length $B_1$ (short stroke)

► Two lube connections per roller runner block, attach one connection optionally on the left and right end cap and lubricate!

The initial lubrication is done two times for each connection with the partial amount according to table 6:

1. Oil the roller runner block for each connection with the initial partial amount according to table 6.
2. Slide the roller runner block back and forth by at least three times the runner block length for three full cycles.
3. Repeat steps 1 and 2 once again.
4. Check whether a film of grease is visible on the roller guide rail.

Size	Initial lubrication amount		
	Normal stroke Partial amount (cm <sup>3</sup> )	Short stroke Partial amount per connection (cm <sup>3</sup> )	
		L	R
<b>25</b>	0.8 (3x) <sup>1)</sup>	0.8 (3x) <sup>1)</sup>	0.8 (3x) <sup>1)</sup>
<b>35</b>	1.3 (2x)	1.3 (2x)	1.3 (2x)
<b>45</b>	1.5 (2x)	1.5 (2x)	1.5 (2x)
<b>55</b>	2.0 (2x)	2.0 (2x)	2.0 (2x)
<b>65</b>	4.0 (2x)	4.0 (2x)	4.0 (2x)

**Table 6**

- 1) When using the lubrication plate (see "Lubrication plate for size 25"), the initial lubrication quantity should be increased by at least 0.24 cm<sup>3</sup>.

## Relubrication of Roller runner blocks

### Stroke $\geq 2 \cdot$ roller runner block $B_1$ (normal stroke)

- ▶ Apply the minimum quantity according to table 7 at the lube connection until the relubrication interval has been reached.

### Stroke $< 2 \cdot$ roller runner block Length $B_1$ (short stroke)

- ▶ Two lube connections per roller runner block, attach one connection optionally on the left and right end cap and lubricate!
- ▶ Apply the minimum quantity according to table 7 at the lube connection until the relubrication interval has been reached. Calculate the actually introduced quantity as described under relubrication (normal stroke) and adapt the piston distributor size and/or cycle time, if applicable.
- ▶ During the lubrication circuit, the roller runner block should be moved with a lubricating stroke of 3 roller runner block length  $B_1$ ; as minimum lubricating stroke, however, roller runner block length  $B_1$  should be moved.

### Notes

The actually applied quantity in the relubrication interval is calculated taking into account the mean travel speed, the selected piston distributor and the cycle time according to formula 2. The calculated quantity must be greater than or equal to the relubrication quantity according to table 7. If it is lower, either the cycle time is to be reduced and/or a larger piston distributor is to be selected. The calculation process according to formula 2 is to be repeated.

### Calculation of the relubrication quantity

$f_{KSS} = 1$  (no coolant/lubricant charge)

$f_{KSS} = 5$  (with coolant/lubricant charge)

### Calculation of the relubrication interval for the application

### Load-dependent relubrication intervals

#### This applies to the following conditions:

- ▶ Maximum speed:  $v_{max} = 4$  m/s
- ▶ No media pressurization
- ▶ Standard seals
- ▶ Ambient temperature:  $T = 10 - 40$  °C

### Key

- $V_{\dot{O}l}$  = Introduced relubrication quantity in the relubrication interval (cm<sup>3</sup>)
- $V_{min}$  = Relubrication quantity (cm<sup>3</sup>)
- $s$  = Relubrication interval according to figure 3 (km)
- $K_v$  = Piston distributor size according to table 8 (cm<sup>3</sup>)
- $V_m$  = Average speed (including waiting times) (m/s)
- $t_T$  = Cycle time of the central lubrication system (min.)
- $C$  = Dynamic load capacity (N)
- $F_m/C$  = Dynamic equivalent load on bearing (N)
- $S_{AP}$  = Relubrication interval for the application
- $f_{KSS}$  = Correction factor for coolant/lubricant

Size	Relubrication quantity $V_{min}$		
	Normal stroke (cm <sup>3</sup> )	Short stroke per connection (cm <sup>3</sup> )	
		L	R
25	1.2	1.2	1.2
35	1.3	1.3	1.3
45	1.5	1.5	1.5
55	2.0	2.0	2.0
65	4.0	4.0	4.0

**Table 7**

$$V_{\dot{O}l} = \text{rounding-off } \frac{16.67 \cdot S_{AP} \cdot K_v}{v_m \cdot t_T} \geq V_{min} \text{ according to table 7}$$

$$S_{AP} = s \cdot \frac{1}{f_{KSS}}$$



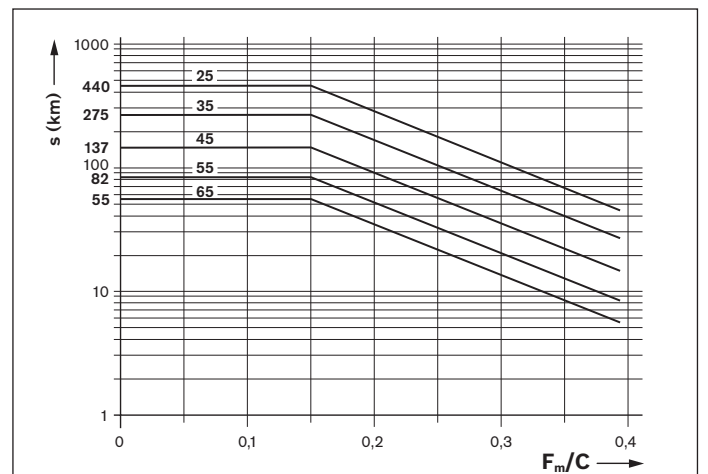



**Formula 2**



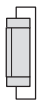







**Fig. 3: Relubrication interval**

# Lubrication RSHP



Oil lubrication with single-line piston distributor systems  
(continued)

Size roller runner block	25				35			
Installation position								
Cycle time (min)	Permissible piston distributor size (cm <sup>3</sup> )							
up to 30	0.06	0.06	0.10	0.06	0.06	0.10	0.06	0.10
30 to 60	0.10	0.10	0.20	0.10	0.10	0.20	0.10	0.20
60 to 90	0.16	0.16	0.40	0.16	0.16	0.40	0.16	0.40
90 to 120	0.20	0.20	0.40	0.20	0.20	0.40	0.20	0.40
> 120	0.40	0.40	0.40	0.40	0.40	0.40	0.40	0.40





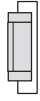

Size roller runner block	45				55			
Installation position								
Cycle time (min)	Permissible piston distributor size (cm <sup>3</sup> )							
up to 30	0.10	0.10	0.16	0.16	0.16	0.20	0.16	0.20
30 to 60	0.16	0.16	0.40	0.20	0.20	0.40	0.20	0.40
60 to 90	0.20	0.20	0.40	0.40	0.40	0.60	0.40	0.60
90 to 120	0.40	0.40	0.40	0.60	0.60	0.60	0.60	0.60
> 120	0.40	0.40	0.40	0.60	0.60	0.60	0.60	0.60

Size roller runner block	65			
Installation position				
Cycle time (min)	Permissible piston distributor size (cm <sup>3</sup> )			
up to 30	0.20	0.20	0.40	0.40
30 to 60	0.40	0.40	0.60	0.60
60 to 90	0.60	0.60	1.00	1.00
90 to 120	1.00	1.00	1.00	1.00
> 120	1.00	1.00	1.00	1.00

Installation positions:

-  Horizontal
-  Horizontal over head
-  Vertical
-  Wall attachment

**Table 8**

When using lube connections which are not offered by Rexroth for the use at the RSHP, an extension for all installation positions is urgently required.

**Calculation example:**

Given data:

<b>Roller runner block</b>	1851 323 2X
<b>Dynamic load capacity C</b>	61000 N
<b>Dynamically equivalent load on bearing</b>	18300 N
<b>Stroke</b>	500 mm
<b>Average speed <math>v_m</math></b>	1.0 m/s
<b>Temperature T</b>	20 – 30 °C
<b>Installation position</b>	Horizontal
<b>Lubrication</b>	Single-line distributor system for all axes with Shell Tonna S3 M220 oil
<b>Cycle time of the central lubrication system <math>t_T</math></b>	20 min
<b>Exposure to contaminants</b>	Exposure to cooling lubricants

Calculation of the relubrication quantity:

<b>Normal stroke or short stroke</b>	Normal stroke	Stroke $\geq 2 \cdot$ roller runner block length B1 500 mm $\geq 2 \times 79.6$ mm 500 mm $\geq 159.2$ mm i.e. normal stroke applies
<b>Initial lubrication amount</b>	1.30 cm <sup>3</sup> (2x)	according to table 6
<b>Relubrication quantity</b>	$V_{\text{öl}} = 1.30 \text{ cm}^3$	according to table 7
<b>Piston distributor size</b>	$K_v = 0.06 \text{ cm}^3$	according to table 8
<b>Load ratio</b>	$F/C = 18300 \text{ N}/61000 \text{ N} = 0.30$	
<b>Relubrication interval with exposure to cooling lubricants</b>	$S_{\text{AP}} = 60 \text{ km} \cdot \frac{1}{f_{\text{KSS}}} = 60 \text{ km} \cdot \frac{1}{5} = 12 \text{ km}$	according to figure 3
<b>Introduced relubrication quantity in the relubrication interval:</b>	$V_{\text{öl}} = \text{rounding-off} \frac{16.67 \cdot S_{\text{AP}} \cdot K_v}{v_m \cdot t_T}$ $V_{\text{öl}} = \text{rounding-off} \frac{16.67 \cdot 12 \cdot 0.06}{1.0 \cdot 20} = 0.6 \text{ cm}^3$	according to formulas 2

Result:

The lubrication dimensioning with a piston distributor of 0.06 cm<sup>3</sup> is **insufficient** since the required relubrication according to table 7 of 1.30 cm<sup>3</sup> is undercut in the relubrication interval. The calculation is to be repeated with a larger piston distributor.

<b>Newly selected piston distributor</b>	$K_v = 0.16 \text{ cm}^3$	
<b>Introduced newly calculated relubrication quantity in the relubrication interval</b>	$V_{\text{öl}} = \text{rounding-off} \frac{16.67 \cdot S_{\text{AP}} \cdot K_v}{v_m \cdot t_T}$ $V_{\text{öl}} = \text{rounding-off} \frac{16.67 \cdot 12 \cdot 0.16}{1.0 \cdot 20} = 1.6 \text{ cm}^3$	according to formulas 2

Result:

The lubrication dimensioning with a piston distributor of 0.16 cm<sup>3</sup> is **sufficient** since the required relubrication according to table 7 of 1.30 cm<sup>3</sup> is exceeded in the relubrication interval.

## Lubrication RSHP

### Lubrication from above

#### **Standard roller runner blocks with open lube connections for lubrication from above**

Standard roller runner blocks comprise of a lube port on top which is already opened for lubrication but closed with a screw when being delivered.

- ▶ Unscrew the closing screw (1) from the lube port (3).
- ▶ Insert the O-ring (2) into the groove (the O-ring is included in the scope of delivery of the roller runner block).

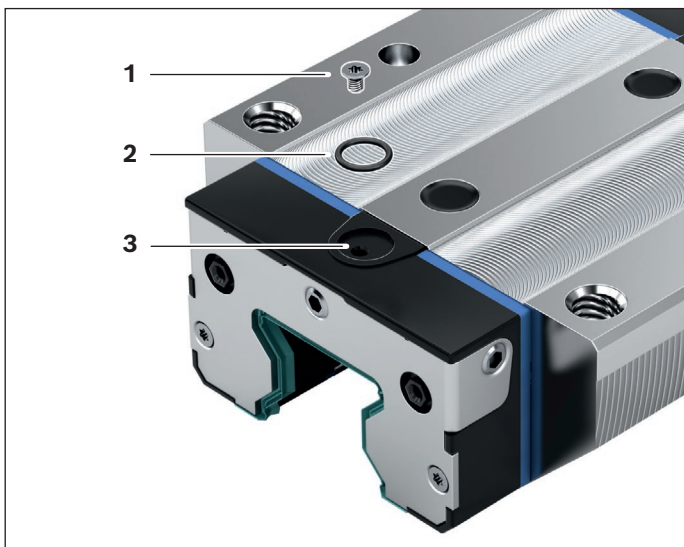

# Lubrication for heavy-duty roller rail system

## Grease lubrication with grease guns or progressive lubrication systems

**⚠** See chapter "Note on lubrication".

### Grease lubricant

We recommend using **Dynalub 510**. For further information, please refer to chapter "Note on lubrication".

### Initial lubrication of the roller runner block (basic lubrication)

#### Stroke $\geq 2 \cdot$ roller runner block $B_1$ (normal stroke)

► One lube connection per roller runner block, attach optionally on the left or right end cap and lubricate! The initial lubrication is done three times with the partial amount according to table 9:

1. Pre-lubricate the roller runner blocks with an initial partial amount according to table 9 by slowly applying pressure to the grease gun.
2. Slide the roller runner block back and forth by at least three times the runner block length for three full cycles (with size 125 by at least 300 mm).
3. Repeat steps 1 and 2 twice more.
4. Check whether a film of grease is visible on the roller guide rail.

#### Stroke $< 2 \cdot$ roller runner block Length $B_1$ (short stroke)

► Two lube connections per roller runner block, attach one connection optionally on the left and right end cap and lubricate!

The initial lubrication is done three times for each connection with the partial amount according to table 9:

1. Pre-lubricate the roller runner blocks for each connection with an initial partial amount according to table 9 by slowly applying pressure to the grease gun.
2. up to 4 Carry out the process as for the initial lubrication (normal stroke).

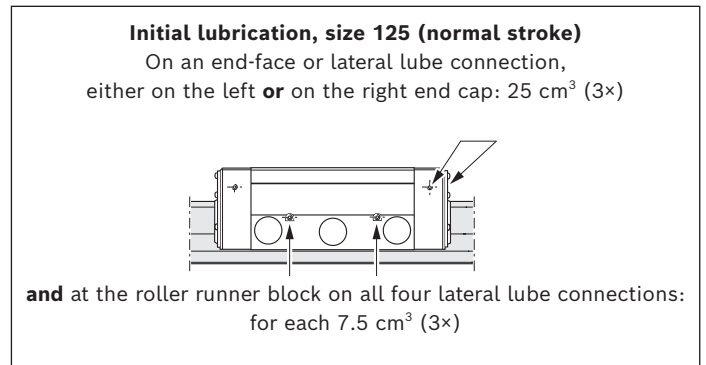

**Fig. 4**

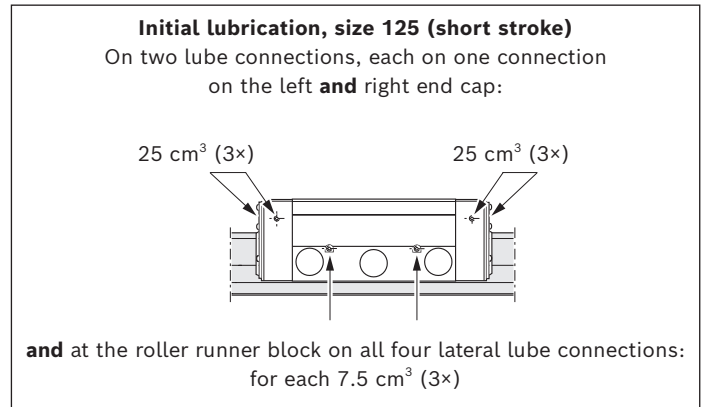

**Fig. 5**

Size	Initial lubrication		
	Normal stroke Partial amount (cm <sup>3</sup> )	Short stroke Partial amount per connection (cm <sup>3</sup> )	
		left	right
<b>65 FXS</b>	3.2 (3×)	3.2 (3×)	3.2 (3×)
<b>100</b>	15.0 (3×)	15.0 (3×)	15.0 (3×)
<b>125</b>	according to figure 4	Connections left, right <b>and</b> lateral according to figure 5	

**Table 9**

### Relubrication of Roller runner blocks

#### Stroke $\geq 2 \cdot$ roller runner block $B_1$ (normal stroke)

- ▶ Once the relubrication interval according to figure 8 has been reached, relubricate the amount stated in table 10.

#### Stroke $< 2 \cdot$ roller runner block Length $B_1$ (short stroke)

- ▶ Once the relubrication interval according to figure 8 has been reached, relubricate the amount stated in table 10 for each lube connection.
- ▶ For each lubrication cycle, the roller runner block should be moved with a lubricating stroke of  $3 \cdot$  roller runner block length  $B_1$ ; as minimum lubricating stroke, however, roller runner block length  $B_1$  should be moved.

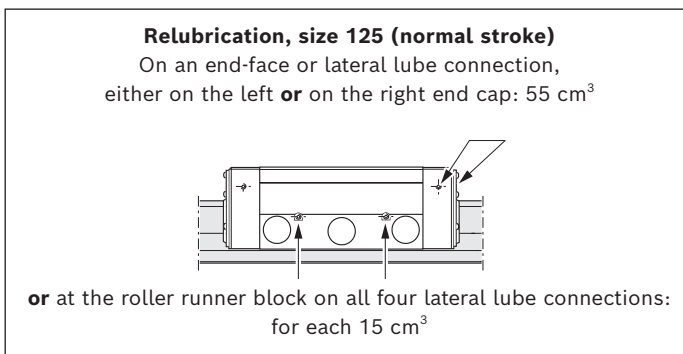

Fig. 6

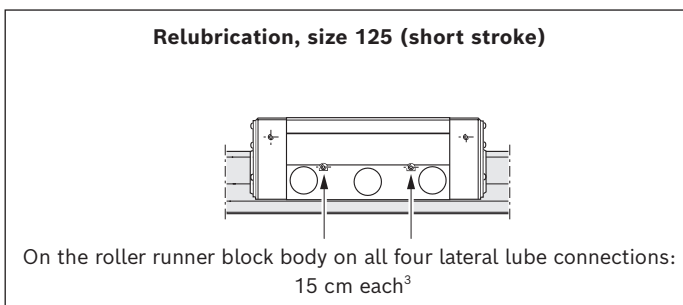

Fig. 7

Size	Relubrication		
	Normal stroke Partial amount ( $\text{cm}^3$ )	Short stroke Partial amount per connection ( $\text{cm}^3$ )	
		left	right
65 FXS	3.2	3.2	3.2
100	15.0	15.0	15.0
125	according to figure 6	Lateral connections according to figure 7	

Table 10

### Load-dependent relubrication intervals ("dry axes")

#### This applies to the following conditions:

- ▶ Maximum speed:  $v_{\text{max}} = 2 \text{ m/s}$
- ▶ No media pressurization
- ▶ Standard seals
- ▶ Ambient temperature:  $T = 10 - 40 \text{ }^\circ\text{C}$

#### Key to illustration

- $s$  = Lubrication interval as travel distance (km)
- $C$  = Dynamic load capacity (N)
- $F_m/C$  = Dynamic equivalent load on bearing (N)

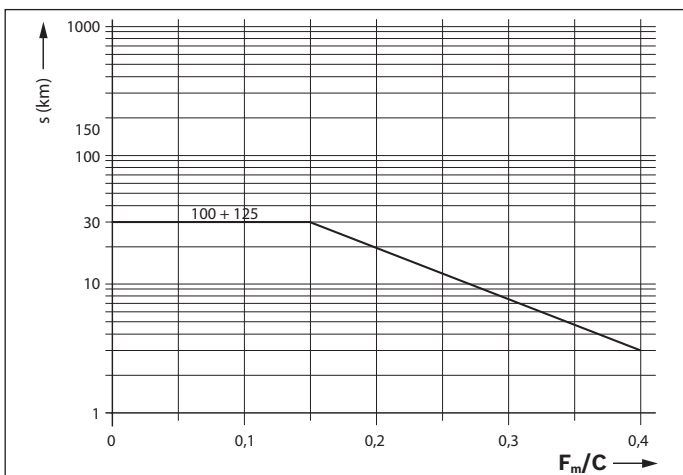

Fig. 8

# Lubrication for heavy-duty roller rail system

## Liquid grease lubrication with single-line piston distributor systems

**⚠** See chapter "Note on lubrication".

### Liquid grease

We recommend using **Dynalub 520**. For further information, please refer to chapter "Note on lubrication".

### Initial lubrication of the roller runner block (basic lubrication)

We recommend carrying out initial lubrication separately using a grease gun before connecting to the central lubrication system. If the initial lubrication is implemented via the central lubrication system, it is to be ensured that all lines and piston distributors are filled. The number of pulses then results from the partial amounts and the piston distributor size according to table 13.

#### Stroke $\geq 2$ · roller runner block $B_1$ (normal stroke)

- ▶ One lube connection per roller runner block, attach optionally on the left or right end cap and lubricate!

The initial lubrication is done three times with the partial amount according to table 11:

1. Pre-lubricate the roller runner blocks with an initial partial amount according to table 11 by slowly applying pressure to the grease gun.
2. Slide the roller runner block back and forth by at least three times the runner block length for three full cycles (with size 125 by at least 300 mm).
3. Repeat steps 1 and 2 twice more.
4. Check whether a film of grease is visible on the roller guide rail.

#### Stroke $< 2$ · roller runner block Length $B_1$ (short stroke)

- ▶ Two lube connections per roller runner block, attach one connection optionally on the left and right end cap and lubricate!

The initial lubrication is done three times for each connection with the partial amount according to table 11:

1. Pre-lubricate the roller runner blocks for each connection with an initial partial amount according to table 11 by slowly applying pressure to the grease gun.
2. up to 4 Carry out the process as for the initial lubrication (normal stroke).

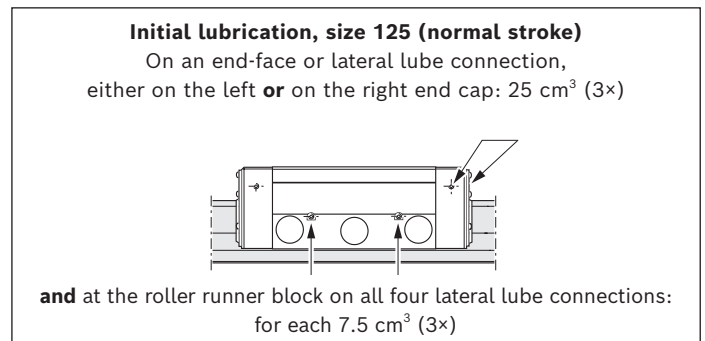

**Fig. 9**

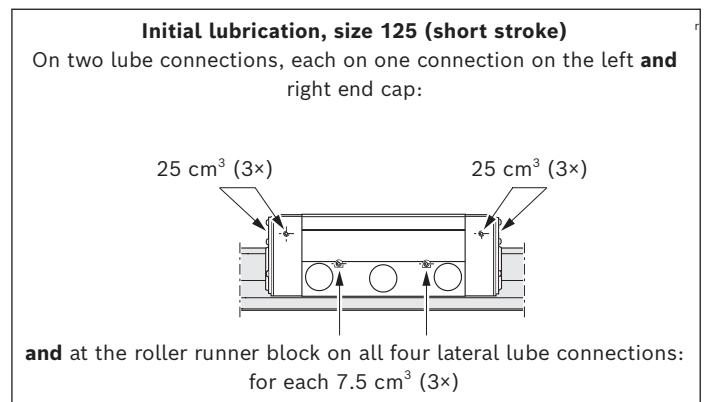

**Fig. 10**

Size	Initial lubrication		
	Normal stroke Partial amount (cm <sup>3</sup> )	Short stroke Partial amount per connection (cm <sup>3</sup> )	
		left	right
<b>65 FXS</b>	3.2 (3×)	3.2 (3×)	3.2 (3×)
<b>100</b>	15.0 (3×)	15.0 (3×)	15.0 (3×)
<b>125</b>	according to figure 9	Connections left, right <b>and</b> lateral according to figure 10	

**Table 11**

## Relubrication of Roller runner blocks

### Stroke $\geq 2 \cdot$ roller runner block $B_1$ (normal stroke)

- ▶ Apply the minimum quantity according to table 12 at the lube connection until the relubrication interval (figure 13) has been reached.

### Stroke $< 2 \cdot$ roller runner block Length $B_1$ (short stroke)

- ▶ Apply the minimum quantity according to table 12 for each lube connection until the relubrication interval (figure 13) has been reached.  
The number of pulses required for this purpose and the lubrication cycle are to be determined in a similar way as the relubrication (normal stroke).
- ▶ For each lubrication cycle, the roller runner block should be moved with a lubricating stroke of  $3 \cdot$  roller runner block length  $B_1$ ; as minimum lubricating stroke, however, roller runner block length  $B_1$  should be moved.

### Notes

The number of pulses required for this purpose is the integer quotient of the minimum relubrication amount as per table 12 and the smallest permissible piston distributor size (minimum pulse quantity) according to table 13. The smallest permissible piston distributor size also depends on the installation position.

The lubricating cycle time is then the result of dividing the relubrication interval (according to figure 13) by the determined number of pulses (see sizing example).

### Load-dependent relubrication intervals ("dry axes")

#### This applies to the following conditions:

- ▶ Maximum speed:  $v_{max} = 2$  m/s
- ▶ No media pressurization
- ▶ Standard seals
- ▶ Ambient temperature:  $T = 10 - 40$  °C

#### Key to illustration

$s$  = Lubrication interval as travel distance (km)  
 $C$  = Dynamic load capacity (N)  
 $F_m/C$  = Dynamic equivalent load on bearing (N)

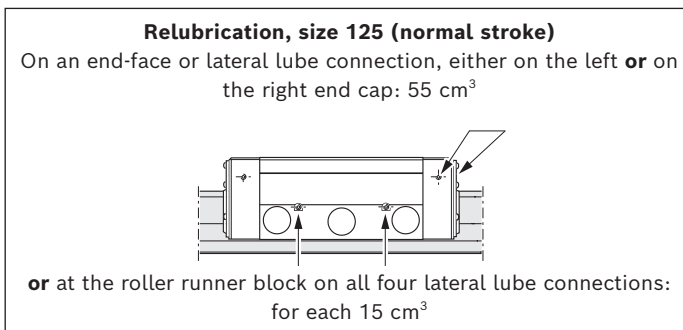

**Fig. 11**

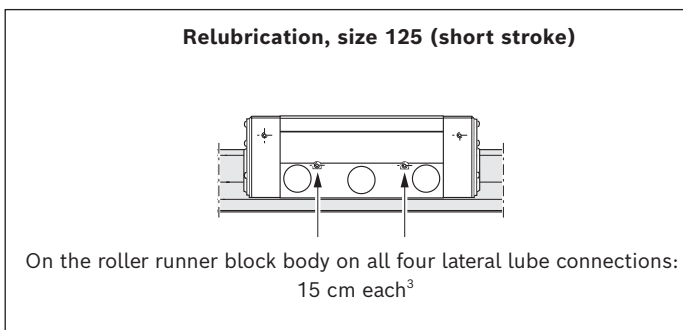

**Fig. 12**

Size	Relubrication Normal stroke (cm³)	Short stroke per connection (cm³)	
		left	right
65 FXS	3.2	3.2	3.2
100	15.0	15.0	15.0
125	according to figure 11	Lateral connections according to figure 12	

**Table 12**

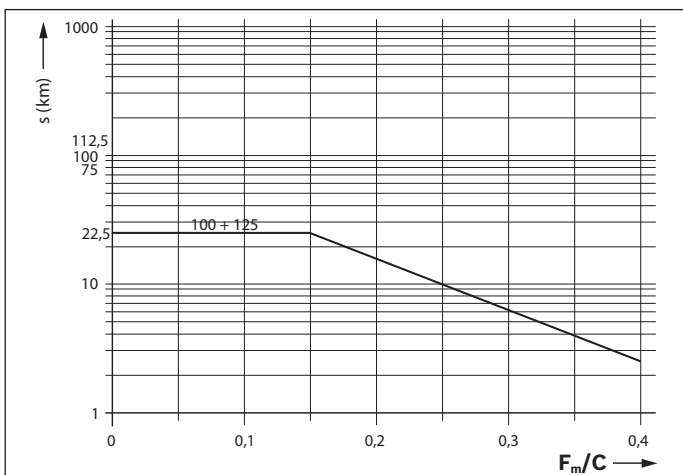

**Fig. 13**

# Lubrication for heavy-duty roller rail system

## Liquid grease lubrication with single-line piston distributor systems (continued)

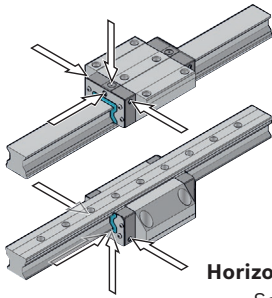
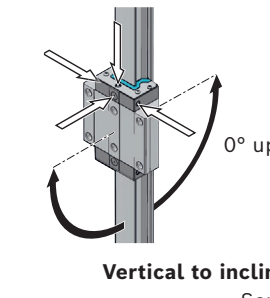
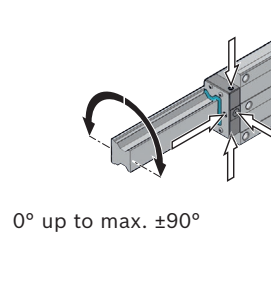
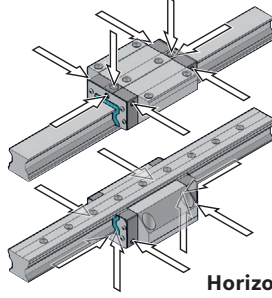
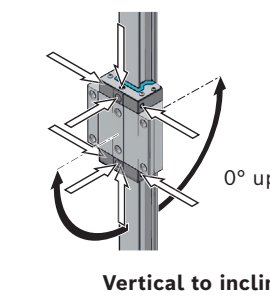
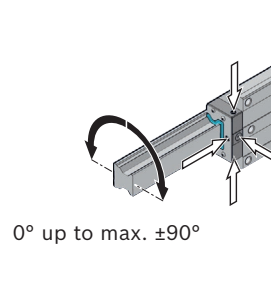
<p><b>Installation position I – Normal stroke</b></p> <p><b>Horizontal</b> 1 lube connection, either on the left <b>or</b> on the right end cap</p>  <p><b>Horizontal over head</b> Same connection</p>	<p><b>Installation position II – Normal stroke</b></p> <p><b>Vertical to inclined horizontal</b> 1 lube connection at the upper end cap</p>  <p>0° up to max. ±90°</p> <p><b>Vertical to inclined over head</b> Same connection</p>	<p><b>Installation position III – Normal stroke</b></p> <p><b>Wall mounting</b> 1 lube connection, either on the left <b>or</b> on the right end cap</p>  <p>0° up to max. ±90°</p>
<p><b>Installation position IV – short stroke</b></p> <p><b>Horizontal</b> 2 lube connections, 1 connection each on the left <b>and</b> right end cap</p>  <p><b>Horizontal over head</b> Same connection</p>	<p><b>Installation position V – short stroke</b></p> <p><b>Vertical to inclined horizontal</b> 2 lube connections, 1 connection each on the top <b>and</b> bottom end cap</p>  <p>0° up to max. ±90°</p> <p><b>Vertical to inclined over head</b> Same connection</p>	<p><b>Installation position VI – short stroke</b></p> <p><b>Wall mounting</b> 2 lube connections, 1 connection each on the left <b>and</b> right end cap</p>  <p>0° up to max. ±90°</p>

**Smallest permissible piston distributor size for liquid grease lubrication via single-line piston distributor<sup>1)</sup>**

Roller runner block		Smallest permissible piston distributor size (≙ minimum pulse quantity) for each connection (cm <sup>3</sup> ) with liquid grease of NLGI class 00		
		Size		
		65 FXS	100	125
<b>Material numbers</b> R18.. ... 10 or ... 60	<b>Installation positions</b>			
	<b>Horizontal I, IV</b>	0.2	0.3	1.5
	<b>Vertical II, V</b>	0.2	0.3	1.5
<b>Wall mounting III, VI</b>		0.2	0.3 (2x) <sup>2)</sup>	0.3 (2x) <sup>2)3)</sup>

**Table 13**

- 1) This applies to the following conditions: Liquid grease Dynalub 520 (or Castrol Tribol GR100-00 PD00, or Elkalub GLS 135/N00) and SKF piston distributor
- 2) Sizes 100 and 125: Either two pulses within a short sequence or two metering valves connected for a pulse
- 3) Size 125: 0.3 cm<sup>3</sup> for each connection when using all four connections in the roller runner block

# Lubrication for heavy-duty roller rail system

## Oil lubrication with single-line piston distributor systems

**▲** See chapter "Note on lubrication".

### Lubricant oil

We recommend **Shell Tonna S3 M220**. For further information, please refer to chapter "Note on lubrication".

### Initial lubrication of the roller runner block (basic lubrication)

We recommend carrying out initial lubrication separately using a manual grease gun before connecting to the central lubrication system.

#### Stroke $\geq 2 \cdot$ roller runner block $B_1$ (normal stroke)

- ▶ One lube connection per roller runner block, attach optionally on the left or right end cap and lubricate!

The initial lubrication is done two times with the partial amount according to table 14:

1. Oil the roller runner block with the initial partial amount according to table 14.
2. Slide the roller runner block back and forth by at least three times the runner block length for three full cycles (with size 125 by at least 300 mm).
3. Repeat steps 1 and 2 once again.
4. Check whether a film of grease is visible on the roller guide rail.

#### Stroke $< 2 \cdot$ roller runner block Length $B_1$ (short stroke)

- ▶ Two lube connections per roller runner block, attach one connection optionally on the left and right end cap and lubricate!

The initial lubrication is done two times for each connection with the partial amount according to table 14:

1. Oil the roller runner block for each connection with the initial partial amount according to table 14.
2. up to 4 Carry out the process as for the initial lubrication (normal stroke).

If the initial lubrication is implemented via the central lubrication system, it is to be ensured that all lines and piston distributors are filled. The number of pulses then results from the partial amounts and the piston distributor size according to table 16.

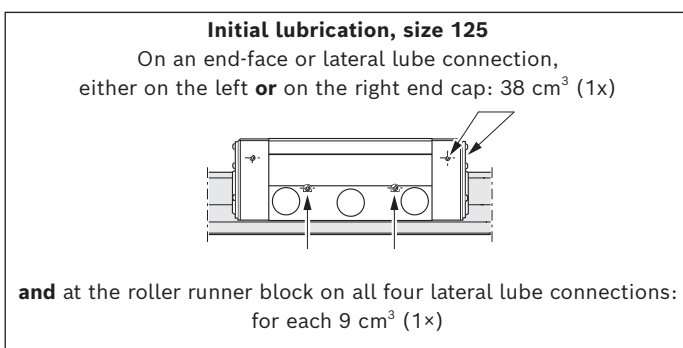

**Fig. 14**

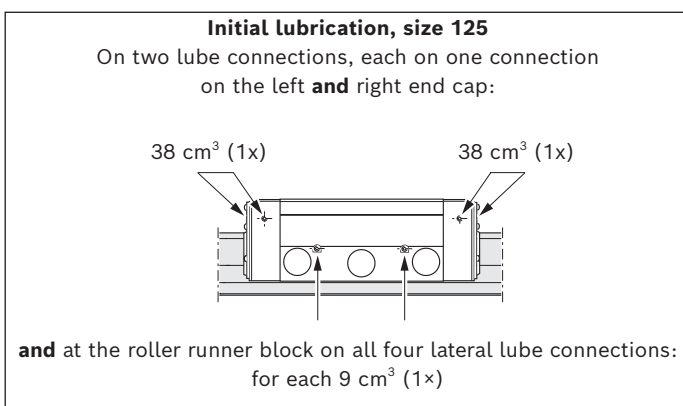

**Fig. 15**

Size	Initial lubrication		
	Normal stroke Partial amount (cm <sup>3</sup> )	Short stroke Partial amount per connection (cm <sup>3</sup> )	
		left	right
65 FXS	4.8 (2x)	4.8 (2x)	4.8 (2x)
100	11.0 (2x)	11.0 (2x)	11.0 (2x)
125	according to figure 14	Connections left, right <b>and</b> lateral according to figure 15	

**Table 14**

**Relubrication of Roller runner blocks**

**Stroke  $\geq 2 \cdot$  roller runner block  $B_1$  (normal stroke)**

- ▶ Apply the minimum quantity according to table 15 at the lube connection until the relubrication interval (figure 18) has been reached.

**Stroke  $< 2 \cdot$  roller runner block Length  $B_1$  (short stroke)**

- ▶ Apply the minimum quantity according to table 15 at the lube connection until the relubrication interval (figure 18) has been reached.  
The number of pulses required for this purpose and the lubrication cycle are to be determined in a similar way as the relubrication (normal stroke).
- ▶ For each lubrication cycle, the roller runner block should be moved with a lubricating stroke of  $3 \cdot$  roller runner block length  $B_1$ ; as minimum lubricating stroke, however, roller runner block length  $B_1$  should be moved.

**Notes**

The number of pulses required for this purpose is the integer quotient of the minimum relubrication amount as per table 15 and the smallest permissible piston distributor size ( $\hat{=}$  minimum pulse quantity) according to table 16. The smallest permissible piston distributor size also depends on the installation position.  
The lubricating cycle time is then the result of dividing the relubrication interval (according to figure 18) by the determined number of pulses.

**Load-dependent relubrication intervals ("dry axes")**

**This applies to the following conditions:**

- ▶ Maximum speed:  $v_{max} = 2$  m/s
- ▶ No media pressurization
- ▶ Standard seals
- ▶ Ambient temperature:  $T = 20 - 30$  °C

**Key to illustration**

$s$  = Lubrication interval as travel distance (km)  
 $C$  = Dynamic load capacity (N)  
 $F_m/C$  = Dynamic equivalent load on bearing (N)

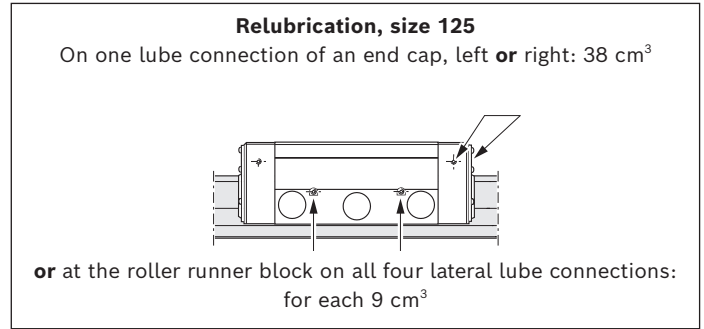

**Fig. 16**

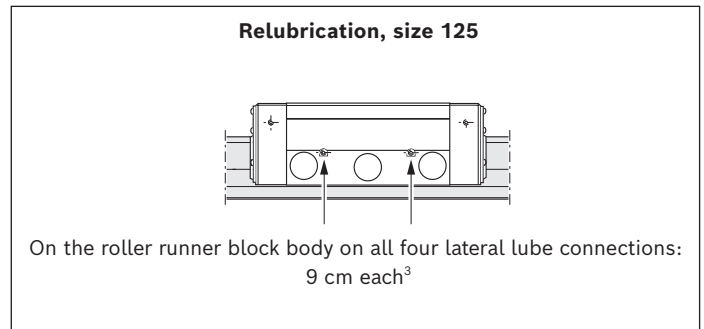

**Fig. 17**

Size	Relubrication		
	Normal stroke (cm <sup>3</sup> )	Short stroke	
		Partial amount per connection (cm <sup>3</sup> )	
		left	right
65 FXS	4.8	4.8	4.8
100	11.0	11.0	11.0
125	according to figure 16	Lateral connections according to figure 17	

**Table 15**

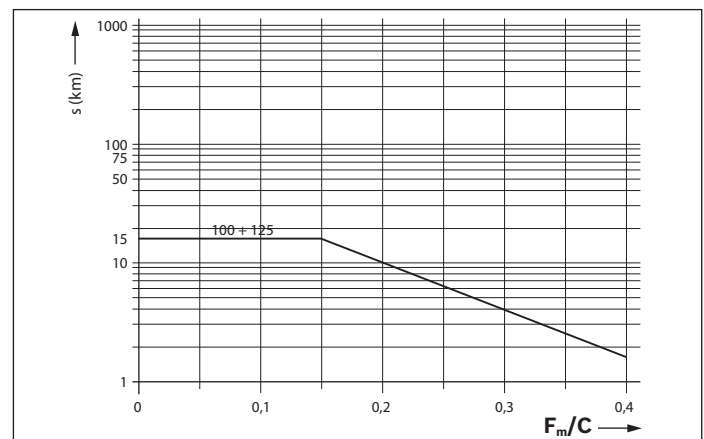

**Fig. 18**

# Lubrication for heavy-duty roller rail system

## Oil lubrication with single-line piston distributor systems (continued)

**Installation position I – Normal stroke**

**Horizontal**  
1 lube connection, either on the left **or** on the right end cap

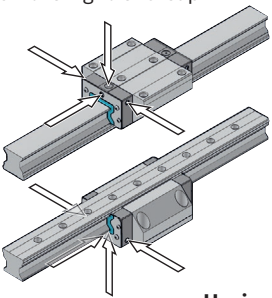

**Horizontal over head**  
Same connection

**Installation position II – Normal stroke**

**Vertical to inclined horizontal**  
1 lube connection at the upper end cap

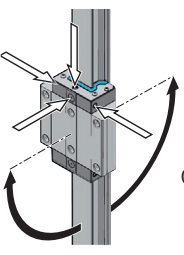

0° up to max. ±90°

**Vertical to inclined over head**  
Same connection

**Installation position III – Normal stroke**

**Wall mounting**  
1 lube connection, either on the left **or** on the right end cap

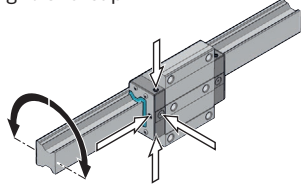

0° up to max. ±90°

**Installation position IV – short stroke**

**Horizontal**  
2 lube connections, 1 connection each on the left **and** right end cap

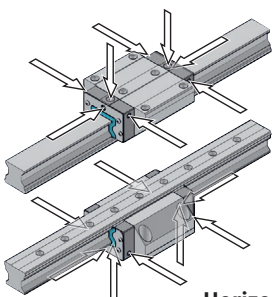

**Horizontal over head**  
Same connection

**Installation position V – short stroke**

**Vertical to inclined horizontal**  
2 lube connections, 1 connection each on the top **and** bottom end cap

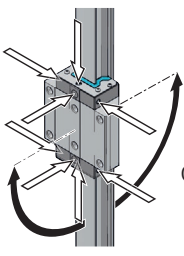

0° up to max. ±90°

**Vertical to inclined over head**  
Same connection

**Installation position VI – short stroke**

**Wall mounting**  
2 lube connections, 1 connection each on the left **and** right end cap

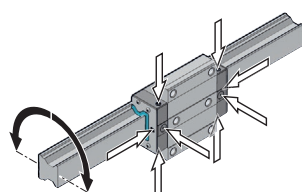

0° up to max. ±90°

### Smallest permissible piston distributor size for oil lubrication via single-line piston distributor<sup>1)</sup>

Roller runner block		Smallest permissible piston distributor size ( $\Delta$ minimum pulse quantity) for each connection (cm <sup>3</sup> ) with oil viscosity of 220 mm <sup>2</sup> /s		
		Size		
Material numbers	Installation positions	65 FXS	100	125
R18.. ... 10 or ... 60	Horizontal I, IV	0.6	1.5	1.5
	Vertical II, V	0.6	1.5	1.5
	Wall mounting III, VI	1.5	1.5 (3×) <sup>2)</sup>	1.5 (3×) <sup>2)3)</sup>

**Table 16**

- 1) This applies to the following conditions: Lubricant oil Shell Tonna S3 M220 and SKF piston distributor
- 2) Sizes 100 and 125: Either three pulses within a short sequence or three metering valves connected for a pulse
- 3) Size 125: 1.5 cm<sup>3</sup> for each connection when using all four connections in the roller runner block

**Configuration example of lubrication of a typical 2-axes application using central lubrication**
**X-axis**

Component or characteristic value	Specifications
<b>Roller runner block</b>	Size 100, 4 pieces, C = 461000 N, material numbers: R1861 223 10
<b>Roller guide rail</b>	Size 100, 2 pieces, L = 1500 mm; material numbers: R1835 263 61
<b>Dynamically equivalent load on bearing</b>	F = 115250 N (for each roller runner block), taking into consideration the preload (here: 8 % C)
<b>Stroke</b>	800 mm
<b>Average speed</b>	$v_m = 1 \text{ m/s}$
<b>Temperature</b>	20 to 30 °C
<b>Installation position</b>	Horizontal
<b>Lubrication</b>	Single-line distributor system for all axes with liquid grease Dynalub 520
<b>Exposure to contaminants</b>	No exposure to media, chips, dust

Configuration sizes	Sizing (for each roller runner block)	Sources of information
<b>Normal stroke or short stroke</b>	Normal stroke: Stroke $\geq 2 \cdot$ roller runner block length $B_1$ 800 mm $\geq 2 \cdot 204 \text{ mm}$ ? 800 mm $\geq 408 \text{ mm}$ ! i.e. normal stroke applies!	Normal stroke formula from catalog, $B_1$ from catalog
<b>Initial lubrication amount</b>	Initial lubrication amount: 15.0 cm <sup>3</sup> (3×)	Initial lubrication amount from table
<b>Relubrication quantity</b>	Relubrication quantity: 15.0 cm <sup>3</sup>	Relubrication amount from table
<b>Installation position</b>	Installation position I – Normal stroke (horizontal)	Installation position from catalog
<b>Piston distributor size</b>	Permissible piston distributor size: 0.3 cm <sup>3</sup>	Piston distributor size from table with size 100, installation position I
<b>Number of pulses</b>	Number of pulses = $\frac{15.0 \text{ cm}^3}{0.3 \text{ cm}^3} = 50$	Number of pulses = $\frac{\text{Relubrication quantity}}{\text{Permissible Piston distributor size}}$
<b>Load ratio</b>	Load ratio = $\frac{115250 \text{ N}}{461000 \text{ N}} = 0.25$	Load ratio = $\frac{F}{C}$ F and C from specifications in catalog
<b>Relubrication interval</b>	Relubrication interval: 10 km	Relubrication interval from figure curve size 100 at load ratio 0.25
<b>Lubrication cycle</b>	Lubrication cycle = $\frac{10 \text{ km}}{50} = 0.2 \text{ km}$	Lubrication cycle = $\frac{\text{Relubrication interval}}{\text{Number of pulses}}$

**Interim result**
**(X-axis)**

For the X-axis, for each roller runner block, a minimum quantity of 0.3 cm<sup>3</sup> of Dynalub 520 is to be supplied every 0.2 km.

## Lubrication for heavy-duty roller rail system

### Sizing example of the lubrication of a typical 2-axes application using central lubrication (continued)

#### Y-axis

Component or characteristic value	Specifications
Roller runner block	Size 100, 4 pieces, C = 461000 N, material numbers: R1851 223 10
Roller guide rail	Size 100, 2 pieces, L = 1500 mm; material numbers: R1835 263 61
Dynamically equivalent load on bearing	F = 115250 N (for each roller runner block), taking into consideration the preload (here: 8 % C)
Stroke	300 mm
Average speed	$v_m = 1$ m/s
Temperature	20 to 30 °C
Installation position	Vertical
Lubrication	Single-line distributor system for all axes with liquid grease Dynalub 520
Exposure to contaminants	No exposure to media, chips, dust

Configuration sizes	Sizing (for each roller runner block)	Sources of information
Normal stroke or short stroke	Short stroke: Stroke < 2 · roller runner block length B <sub>1</sub> 300 mm < 2 · 204 mm? 300 mm < 408 mm! i.e. short stroke applies!	Short stroke formula from catalog, B <sub>1</sub> from catalog
Initial lubrication amount	Initial lubrication amount: 15.0 cm <sup>3</sup> (3×)	Initial lubrication amount from table
Relubrication quantity	Relubrication quantity: 15.0 cm <sup>3</sup>	Relubrication amount from table
Installation position	Installation position V – short stroke (vertical)	Installation position from catalog
Piston distributor size	Permissible piston distributor size: 0.3 cm <sup>3</sup>	Piston distributor size from table with size 100, installation position V
Number of pulses	Number of pulses = $\frac{15 \text{ cm}^3}{0.3 \text{ cm}^3} = 50$	Number of pulses = $\frac{\text{Relubrication quantity}}{\text{Permissible Piston distributor size}}$
Load ratio	Load ratio = $\frac{115250 \text{ N}}{461000 \text{ N}} = 0.25$	Load ratio = $\frac{F}{C}$  F and C from specifications in catalog
Relubrication interval	Relubrication interval: 10 km	Relubrication interval from image Curve size 100 at load ratio 0.25
Lubrication cycle	Lubrication cycle = $\frac{10 \text{ km}}{50} = 0.2 \text{ km}$	Lubrication cycle = $\frac{\text{Relubrication interval}}{\text{Number of pulses}}$

#### Interim result (Y-axis)

For the Y-axis, for each roller runner block, a minimum quantity of 0.3 cm<sup>3</sup> of Dynalub 520 is to be supplied every 0.2 km.

#### Final result (two-axes lubrication)

**The number of connections and minimum quantities determined for each individual axis remain valid.**

**Retrospective lube ports from above for heavy-duty roller runner blocks of size 100 and 65 FXS**

If heavy-duty roller runner blocks are to be fitted with a lube port from above retrospectively, the following is to be observed:

- ⚠ In the groove for the O-ring, another small groove (3) is pre-fitted. Do not open this with a drill. Risk of contamination!
- ▶ Heat up a metal tip (2) with a diameter of 1.5 mm.
- ▶ Carefully open and pierce the groove (3) with the metal tip.
 

Observe the maximum permissible depth  $T_{max}$  according to the table!
- ▶ Insert the O-ring (1) into the groove (the O-ring is not included in the scope of delivery of the roller runner block).

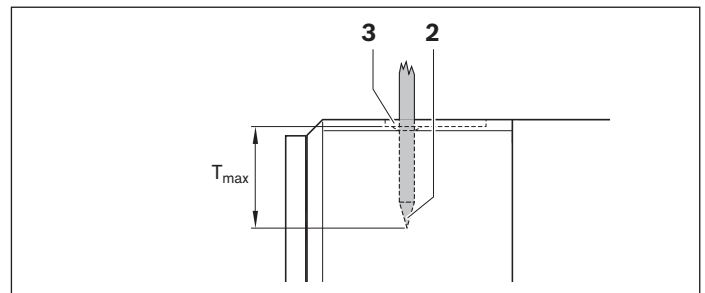
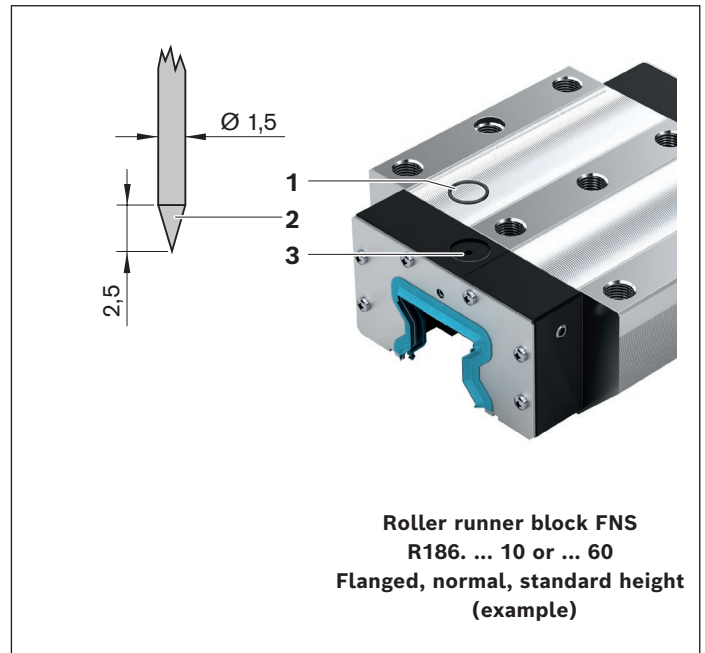

Size	Lubrication opening, top: Maximum permissible depth for piercing $T_{max}$ (mm)
<b>65 FXS, 100</b>	5

# Maintenance

## **Cleaning cycle**

Dirt can settle and encrust on roller guide rails, especially when these are not enclosed.

To ensure that seals and cover strips retain their functionality, this contamination must be removed at regular intervals.

It is advisable to perform at least one "cleaning cycle" over the total travel range every 8 hours.

Depending on the degree of contamination and the use of a coolant/lubricant, a shorter interval is recommended.

Before shutting down the machine, always perform 3 lubricating pulses or lubricating strokes one after another. The lubrication pulses should take place over the maximum possible travel range (cleaning cycle) while the axis is motion.

## **Maintenance of accessories**

All accessories used for scraping the roller guide rail, shall be subject to regular maintenance.

In environments with heavy contamination, it is advisable to replace all the parts directly exposed to such contamination.

We recommend annual maintenance.

## Further information

### Bosch Rexroth Linear Motion Technology homepage

<https://www.boschrexroth.com/web/a74aa994-0afe-4a3b-9e3f-3e615572d31a>

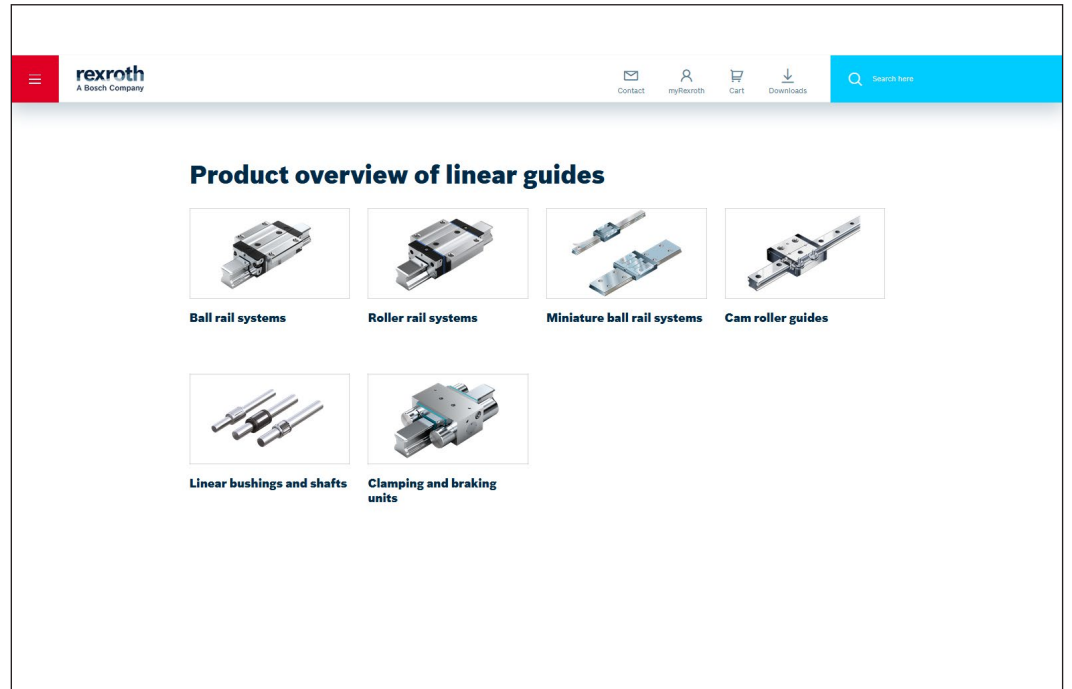

### Linear Motion Designer calculation tool

[www.boschrexroth.com/lmd](http://www.boschrexroth.com/lmd)

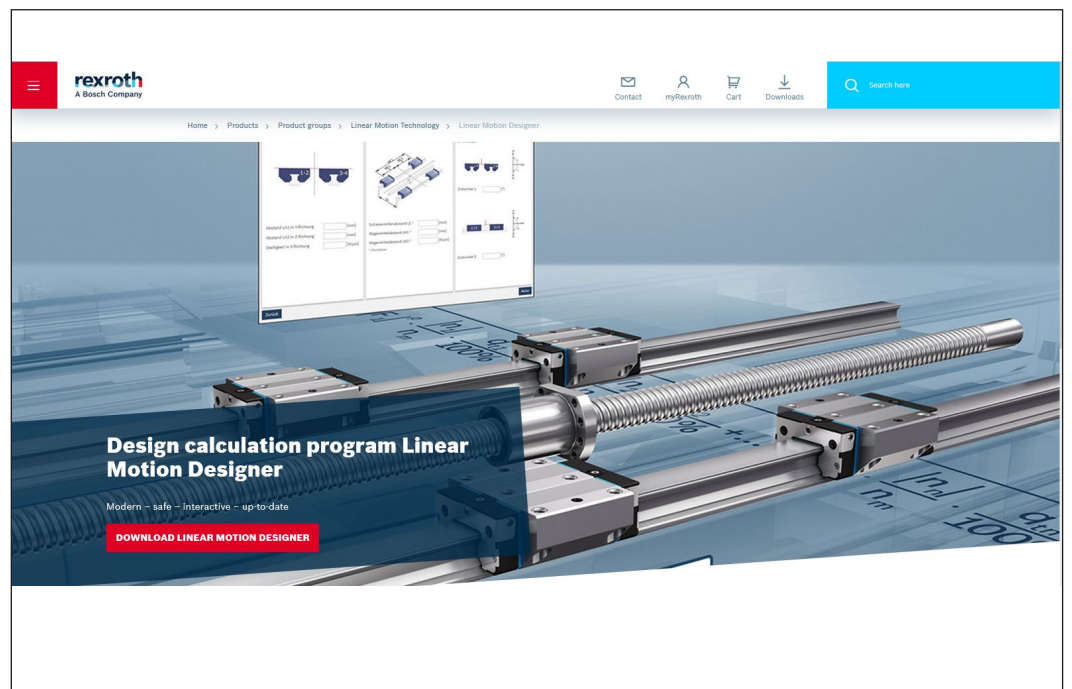

### How-to: Linear Motion Technology

<https://www.youtube.com/playlist?list=PLRO3LeFQeLyNYHTLzi-PeoiuRTpNREvZ>

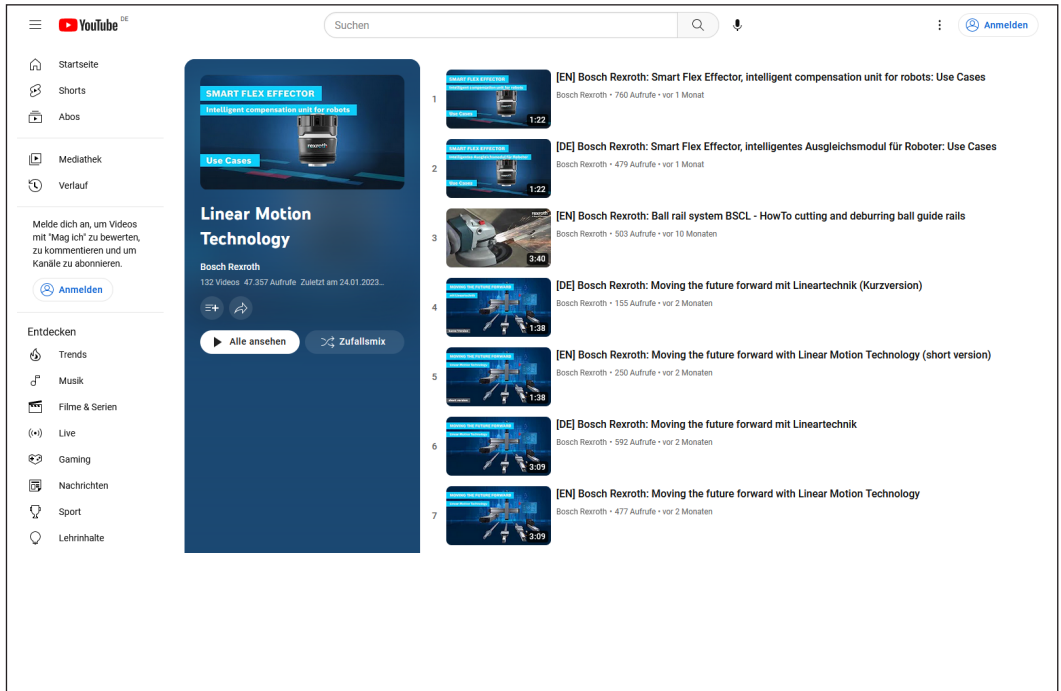

### Academy

<https://www.boschrexroth.com/de/de/academy/>

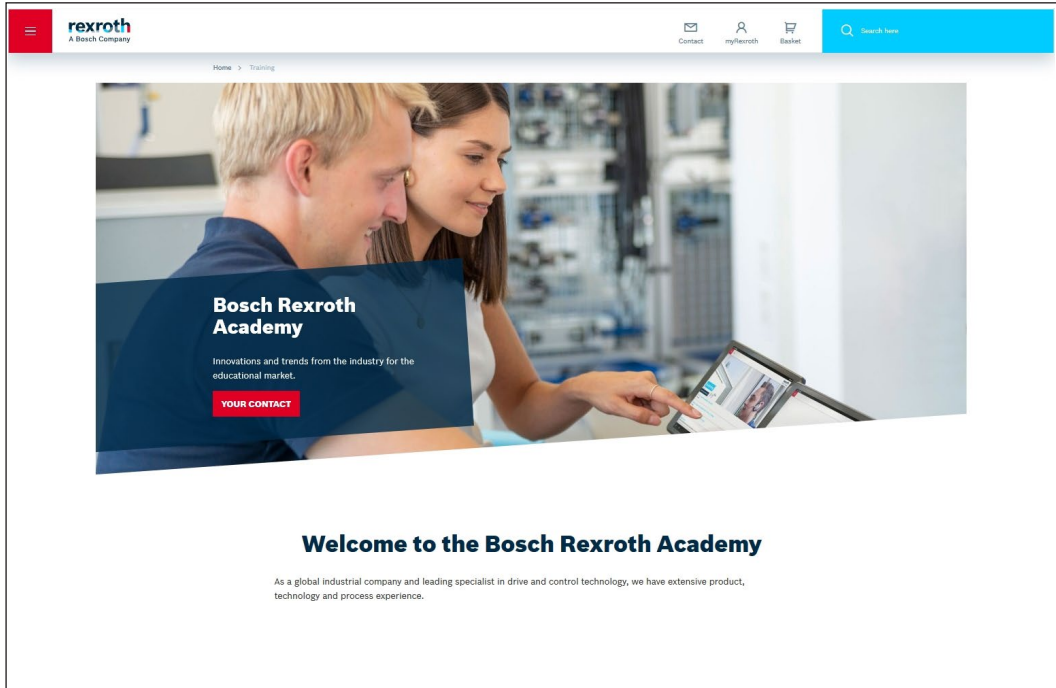

**Service**

<https://www.boschrexroth.com/de/de/service/>

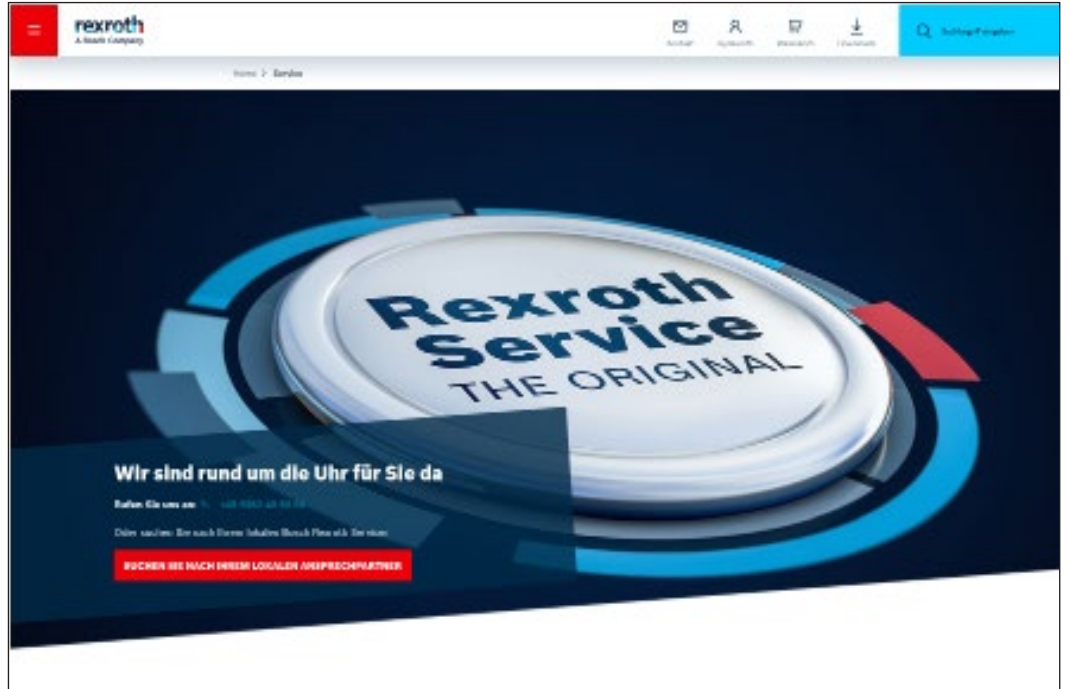

**Rexroth Store**

<https://store.boschrexroth.com/>

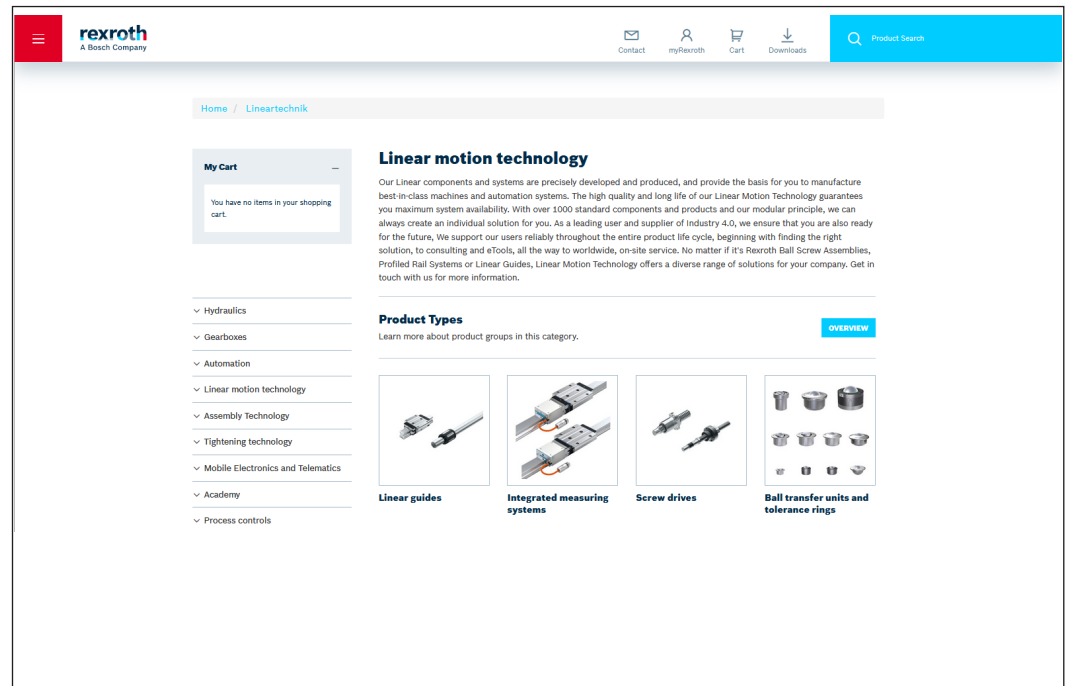

**Bosch Rexroth AG**

Ernst-Sachs-Straße 100  
97424 Schweinfurt, Germany  
Tel. +49 9721 937-0  
Fax +49 9721 937-275  
[www.boschrexroth.com](http://www.boschrexroth.com)

**Find your local contact person here:**

[www.boschrexroth.com/kontakt](http://www.boschrexroth.com/kontakt)