

Schalterhalter
Switch brackets
开关支架

3842 546 251/2006-07

Replaces: –
DE+EN+ZH



Montageanleitung • Assembly instructions • 安装说明书

3 842 537 280

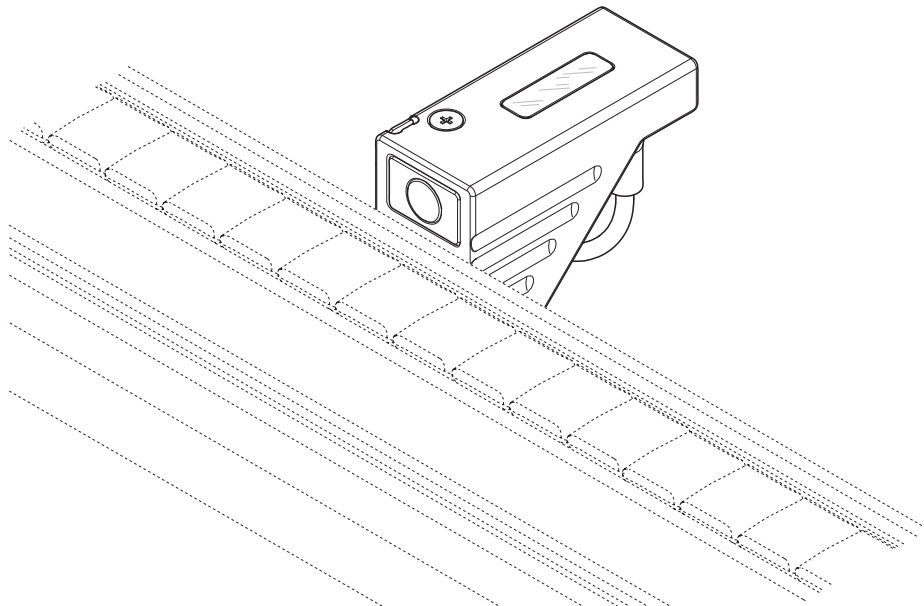

3 842 537 289

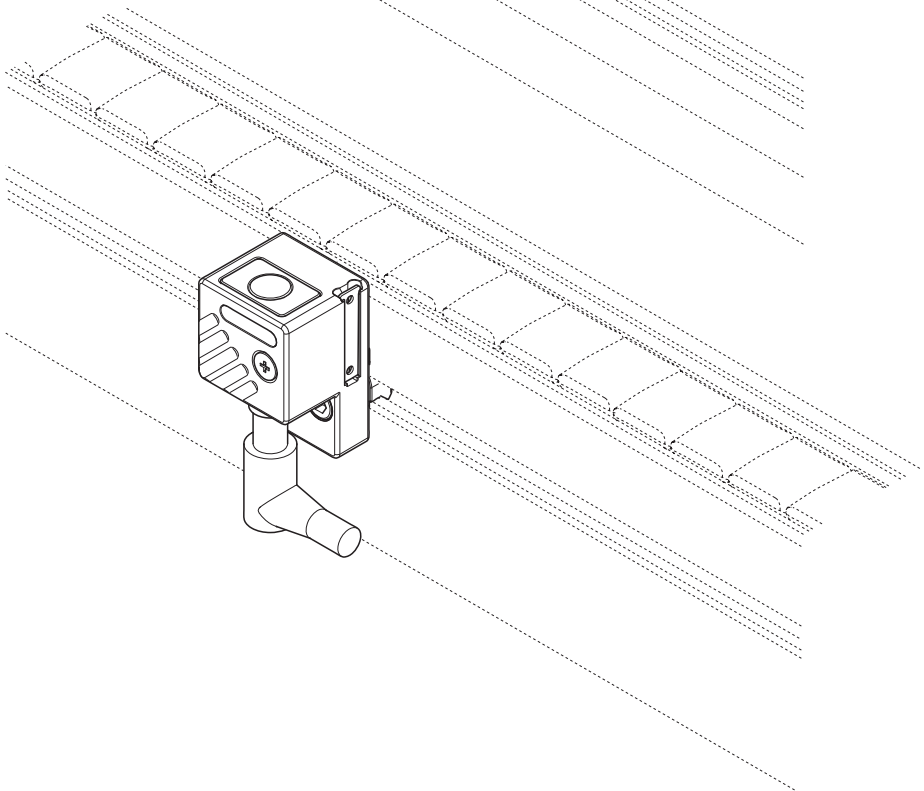

3 842 537 280

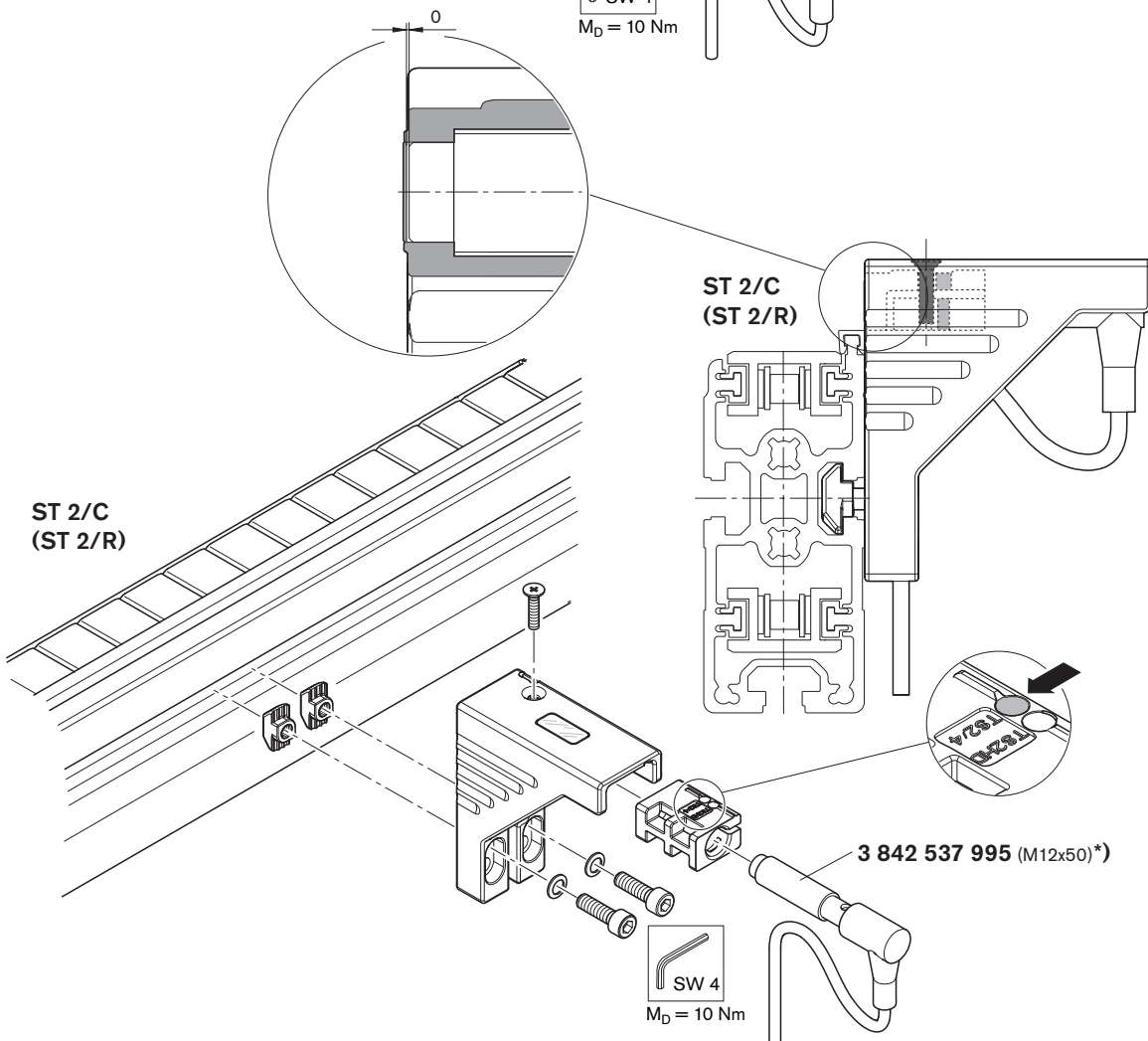
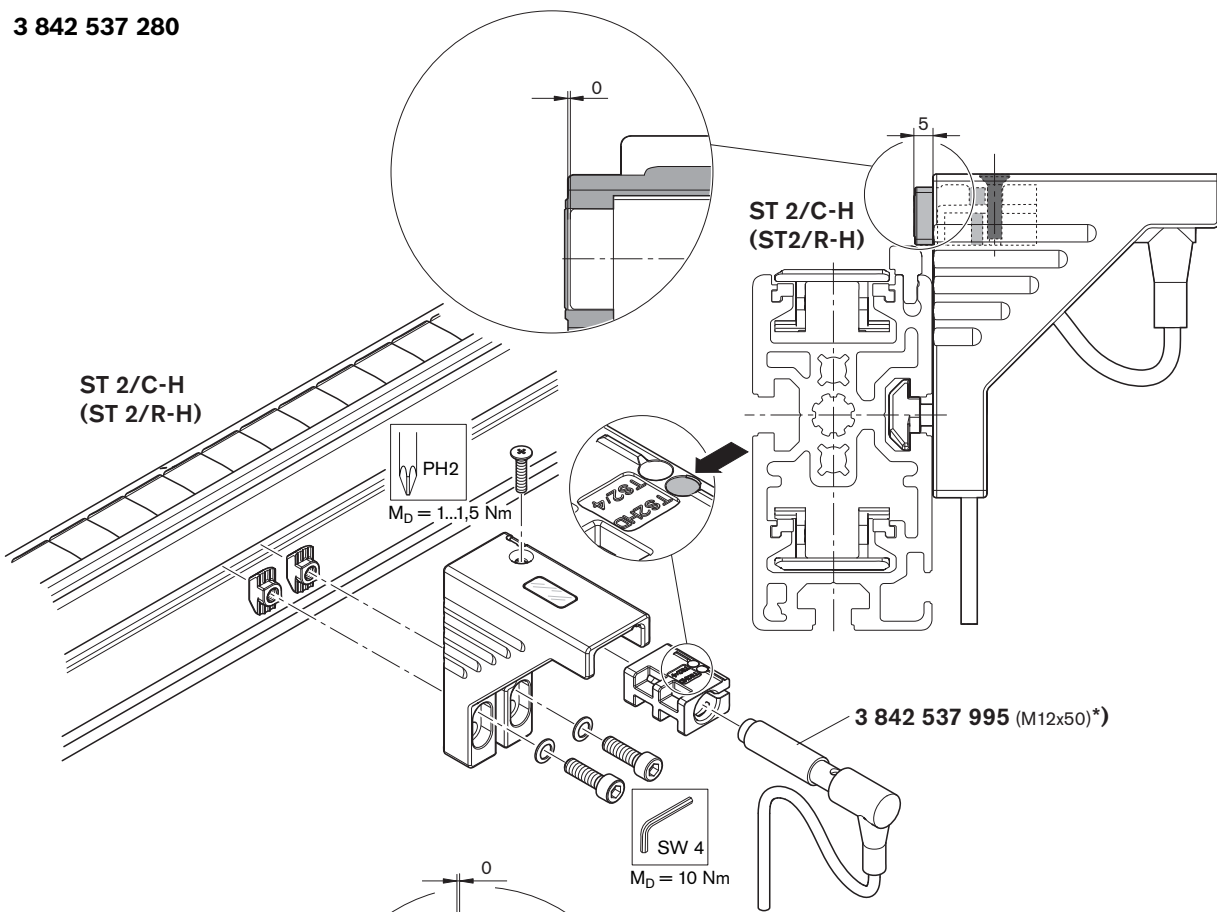

3 842 537 280

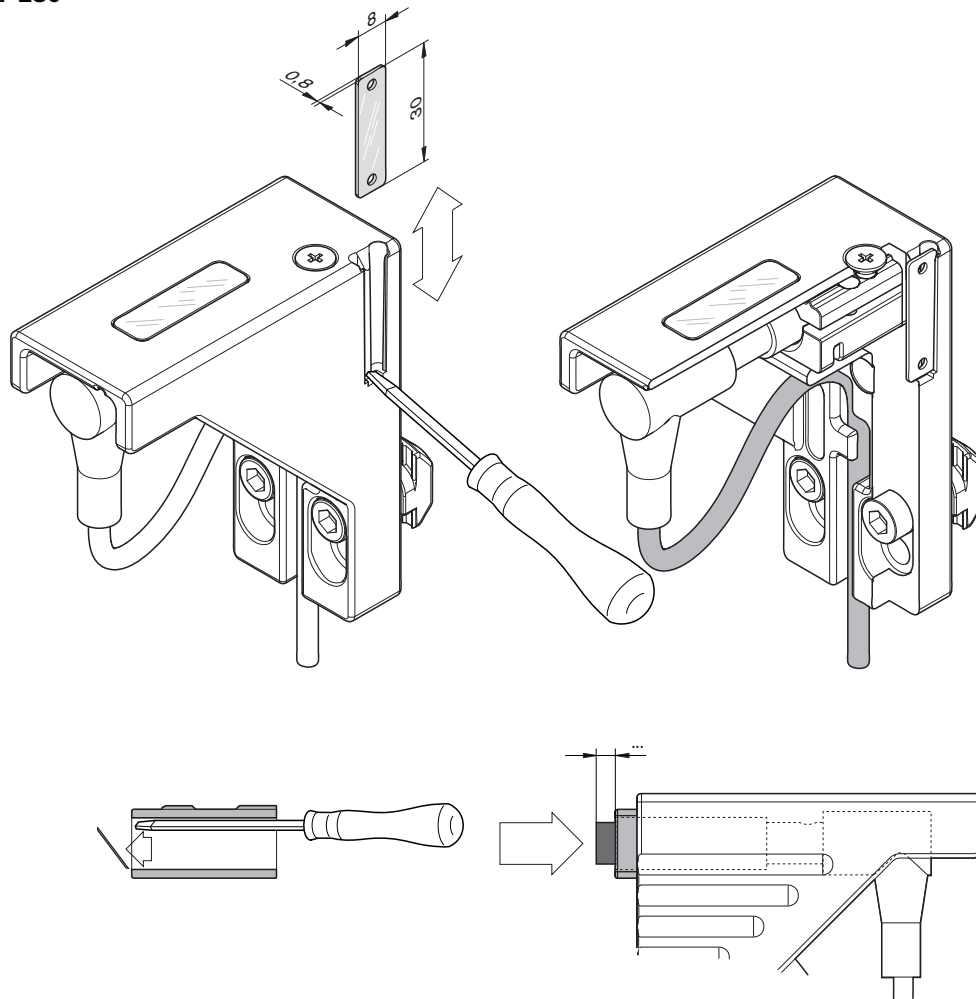

3 842 537 289

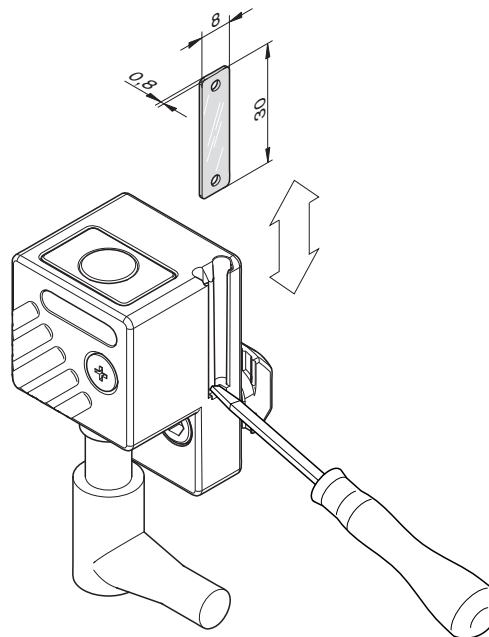

DEUTSCH

ENGLISH

中文

3 842 537 289

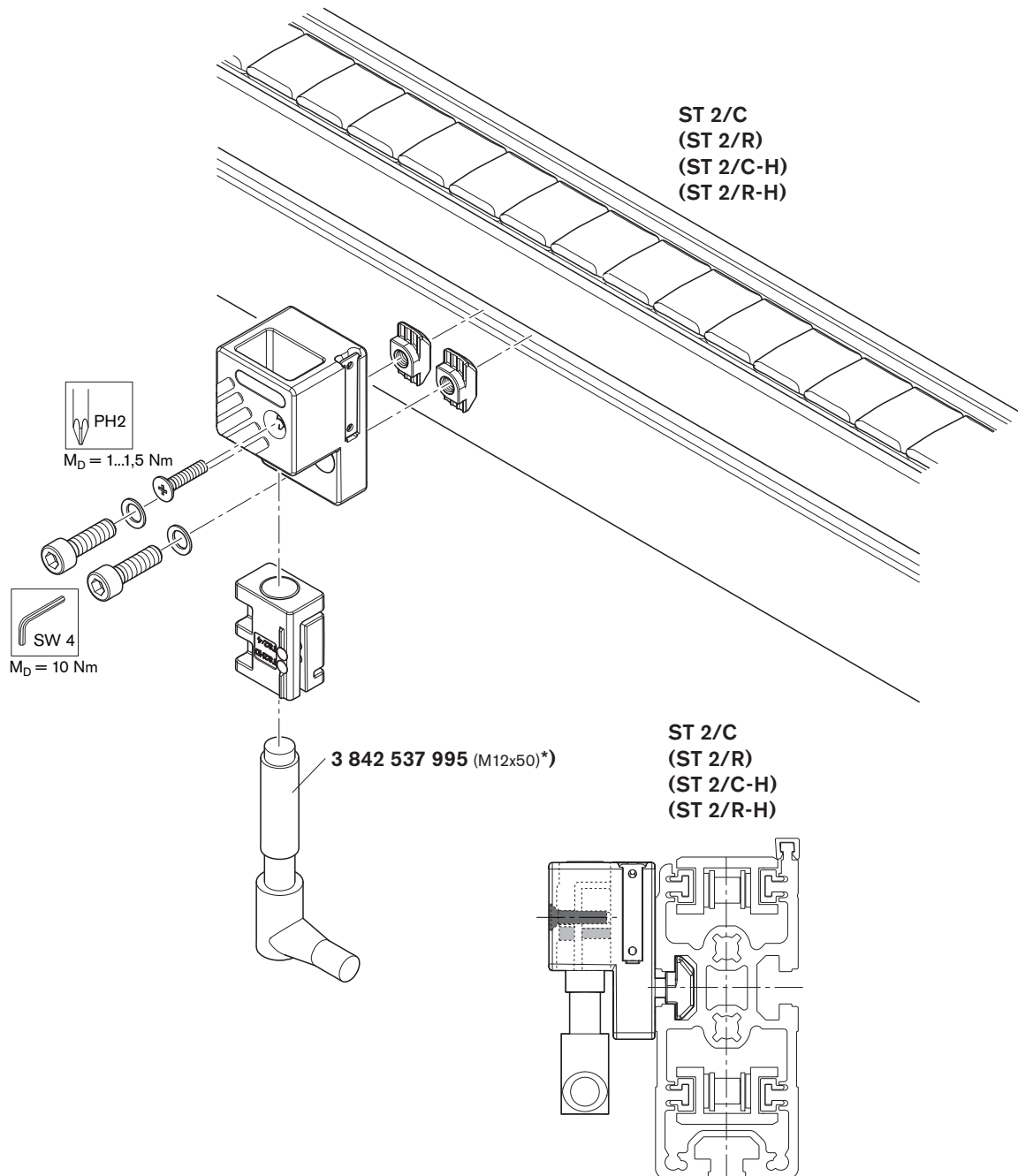

537371-04