

Directional seat valves, direct operated, with solenoid actuation

Type SED ...XN



- ▶ Size 10
- ▶ Component series 1X
- ▶ Maximum operating pressure 350 bar
- ▶ Maximum flow 40 l/min



Information on explosion protection

- ▶ Area of application in accordance with the Explosion Protection Directive 2014/34/EU: **II 3G; II 3D**
- ▶ Type of protection of valve:
 - Ex h IIC T3 Gc X according to EN 80079-36
 - Ex h IIIC T140°C Dc X according to EN 80079-36
- ▶ Type of protection of solenoid coil:
 - Ex ec IIC T3 Gc according to EN 60079-7
 - Ex tc IIIC T140°C Dc according to EN 60079-31

Features

- ▶ 3/2 or 4/2-way version
- ▶ For intended use in potentially explosive atmosphere
- ▶ Porting pattern according to ISO 4401-05-04-0-05
- ▶ Wet-pin DC solenoids
- ▶ Safe switching also with longer standstill periods under pressure
- ▶ Solenoid coil rotatable by 90°
- ▶ Electrical connection with individual connection
- ▶ With manual override, optional

Contents

| | |
|------------------------------|-----------|
| Features | 1 |
| Ordering code | 2, 3 |
| Function, section, symbols | 4, 5 |
| Technical data | 6, 7 |
| Performance limits | 8 |
| Characteristic curves | 9 |
| Dimensions | 10 ... 13 |
| Installation conditions | 14 |
| Throttle insert | 14 |
| Check valve insert | 14 |
| Electrical connection | 15 |
| Project planning information | 16 |
| Further information | 16 |

 **Notice:** The documentation version supplied with the product shall be valid.

Ordering code

| | | | | | | | | | | | | | | |
|----------|----------|------------|-----------|----|-----------|----------|------------|----------|------------|----|-----------|-----------|----------|--|
| 01 | 02 | 03 | 04 | 05 | 06 | 07 | 08 | 09 | 10 | 11 | 12 | 13 | 14 | |
| M | - | SED | 10 | | 1X | / | 350 | C | G24 | | XN | K4 | / | |

| | | |
|----|--------------|------------|
| 01 | Mineral oil | |
| 02 | 3 main ports | 3 |
| | 4 main ports | 4 |
| 03 | Seat valve | SED |
| 04 | Size 10 | 10 |

Symbols

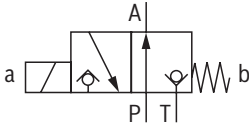
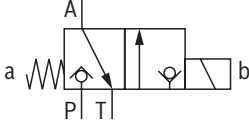
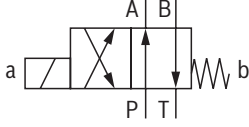
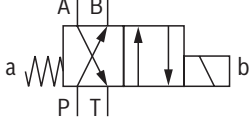
| | | | | |
|----|---|---|---|-----------|
| 05 | Main ports | 3 | 4 | |
| |  | ✓ | - | UK |
| |  | ✓ | - | CK |
| |  | - | ✓ | D |
| |  | - | ✓ | Y |

| | | |
|----|--|------------|
| 06 | Component series 10 ... 19 (10 ... 19: unchanged installation and connection dimensions) | 1X |
| 07 | Operating pressure 350 bar | 350 |
| 08 | Wet-pin solenoid with detachable coil | C |

Voltage

| | | |
|----|--------------------------------|----------------|
| 09 | Direct voltage 24 V | G24 |
| 10 | With concealed manual override | N9 |
| | Without manual override | no code |

Explosion protection

| | | |
|----|--|-----------|
| 11 | "Not igniting", For details, see information on the explosion protection page 7 | XN |
|----|--|-----------|

Electrical connection

| | | |
|----|--|-----------|
| 12 | Individual connection | |
| | Solenoid without mating connector | K4 |
| | For details of electrical connections, see page 15 | |

Ordering code

| | | | | | | | | | | | | | | |
|----------|----------|------------|-----------|----|-----------|----------|------------|----------|------------|----|-----------|-----------|----------|--|
| 01 | 02 | 03 | 04 | 05 | 06 | 07 | 08 | 09 | 10 | 11 | 12 | 13 | 14 | |
| M | - | SED | 10 | | 1X | / | 350 | C | G24 | | XN | K4 | / | |

| | | |
|----|---|----------------|
| 13 | Without check valve insert, without throttle insert | no code |
| | Throttle Ø 1.0 mm | B10 |
| | Throttle Ø 1.2 mm | B12 |
| | Throttle Ø 1.5 mm | B15 |

Seal material (observe compatibility of seals with hydraulic fluid used, see page 6)

| | | |
|----|-----------|----------------|
| 14 | NBR seals | no code |
| | FKM seals | V |

**Notice:**

Representation of the symbols according to ISO 1219-1.

**Notice:**

The manual override cannot be assigned a safety function.

Function, section, symbols: 3/2 directional seat valve

General

Directional control valves of the type SED are direct operated directional seat valves with solenoid actuation. They control start, stop and direction of flow. Directional control valves basically comprise the housing (1), the solenoid (2), the valve seats (7) and (11) and the control spool (4).

The manual override (6) allows for the switching of the valve without solenoid energization.

For unobjectionable functioning, the hydraulic system has to be bled properly.

Basic principle

The initial position of the valve (normally open "UK" or normally closed "CK") is determined by the arrangement of the spring (5). The chamber (3) behind the control

spool (4) is connected to port P and sealed against port T. Thus, the valve is pressure-compensated in relation to the actuating forces (solenoid and spring). By means of the control spool (4), ports P, A and T can be loaded with the maximum operating pressure (350 bar), and the flow can be directed in directions P to A or A to T (see symbols).

In the initial position, the control spool (4) is pressed onto the seat (11) by the spring (5); in spool position, it is pressed onto the seat (7) by the solenoid (2). The flow is blocked.

Seat valves can be used according to the symbols as well as the assigned operating pressures and flows (see performance limits, page 8).

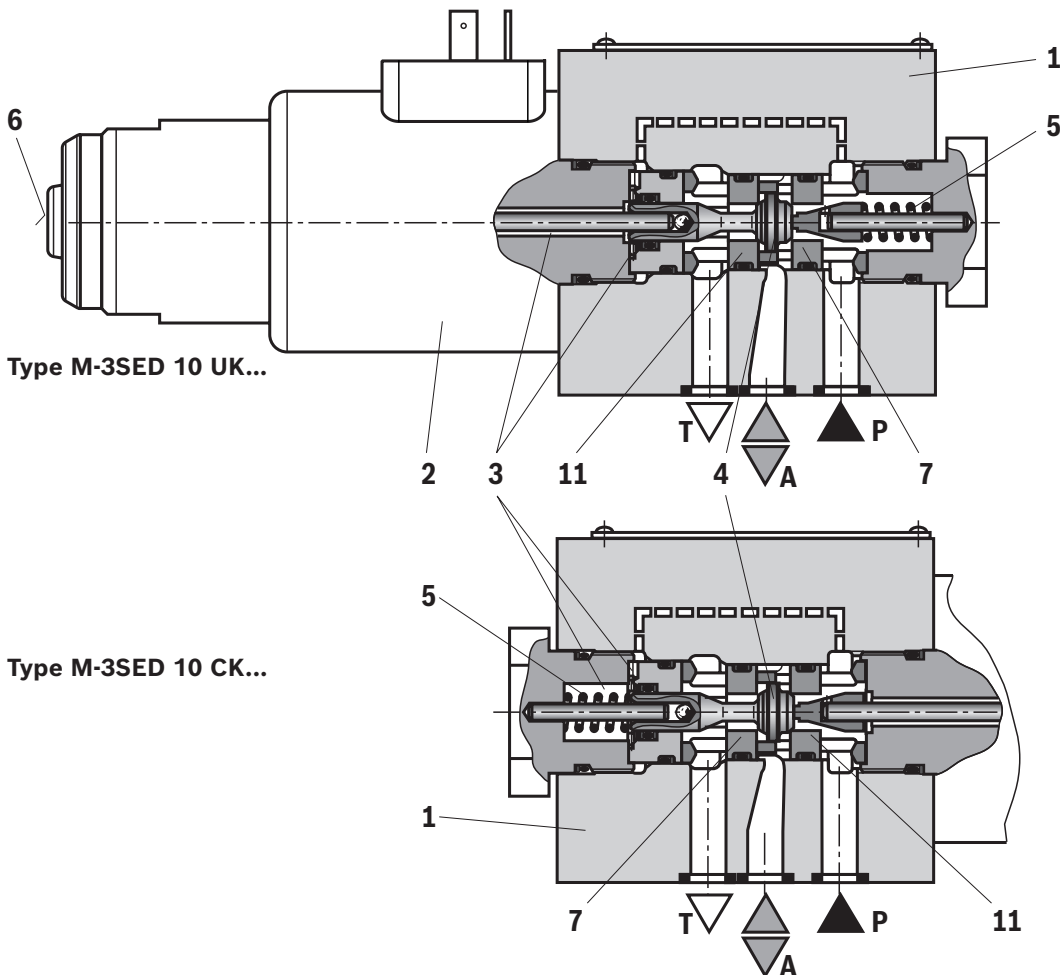

Symbol "UK"

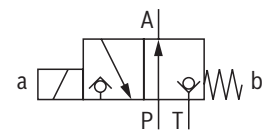

Symbol "CK"

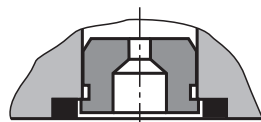
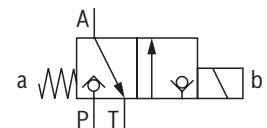

Throttle insert

The use of a throttle insert is required when, due to prevailing operating conditions, flows which exceed the performance limit of the valve occur during the switching process.

Function, section, symbols: 4/2 directional seat valve

With a sandwich plate, the **Plus-1 subplate**, under the 3/2 directional seat valve, the function of a 4/2 directional seat valve is achieved.

Function of the Plus-1 subplate

- ▶ **Initial position:**
The main valve is not actuated. The spring (5) holds the control spool (4) on the seat (11). Port P is blocked and A is connected to T. Apart from that, one control line is connected from connection A to the large area of the control spool (8), which is thus unloaded to connection T. The pressure applied via connection P now pushes the ball (9) onto the seat (10). Now, connection P is connected to B, and A to T.
- ▶ **Transition position:**
When the main valve is operated, the control spool (4) is shifted against the spring (5) and pressed onto the seat (7). During this, port T is blocked, P, A, and B are briefly connected to each other.

- ▶ **Spool position:**
Connection P is connected to A. As the pump pressure acts via connection A on the large area of the control spool (8), the ball (9) is pressed onto the seat (12). Thus, connection B is connected to T, and P to A. The ball (9) in the Plus-1 subplate has a "negative spool overlap".

Notice:
When operating 4/2 directional seat valves to control differential cylinders, the annulus area of the cylinder must only be connected with connection A of the valve. Otherwise, pressure peaks can be created while switching, which will exceed the maximum operating pressure.

The use of the Plus-1 subplate and the seat arrangement offer the following options:

Symbols

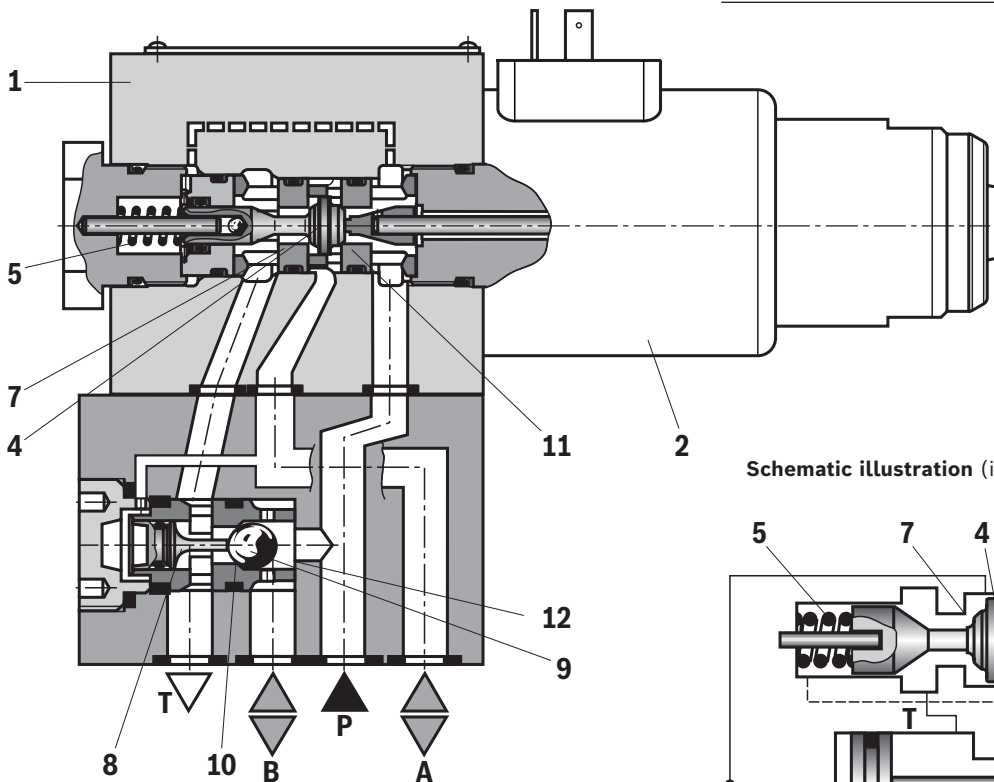
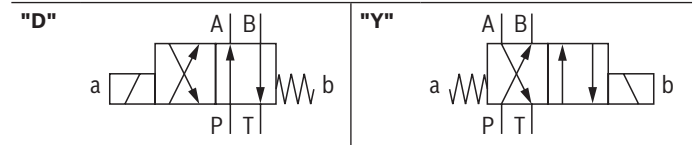

Type M-4SED 10 Y...

Schematic illustration (initial position)

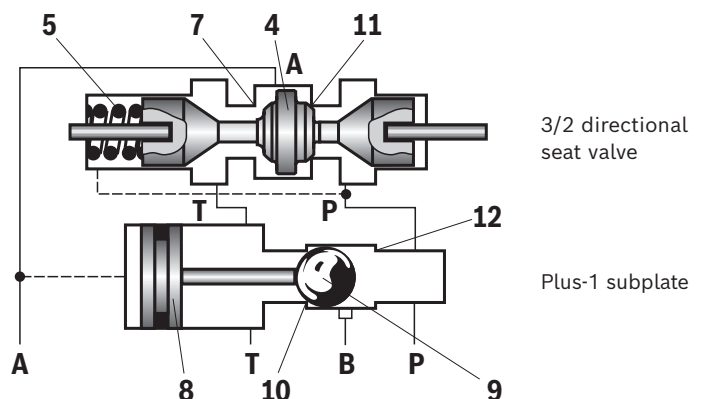

Technical data

(For applications outside these values, please consult us!)

| General | | | | | | | |
|--|---|------------------------------|----|-----|------------------------------|----|-----|
| Type of connection | Subplate mounting | | | | | | |
| Porting pattern | ISO 4401-05-04-0-05 | | | | | | |
| Weight | <table border="0"> <tr> <td>▶ 3/2 directional seat valve</td> <td>kg</td> <td>3.3</td> </tr> <tr> <td>▶ 4/2 directional seat valve</td> <td>kg</td> <td>4.7</td> </tr> </table> | ▶ 3/2 directional seat valve | kg | 3.3 | ▶ 4/2 directional seat valve | kg | 4.7 |
| ▶ 3/2 directional seat valve | kg | 3.3 | | | | | |
| ▶ 4/2 directional seat valve | kg | 4.7 | | | | | |
| Installation position | Any | | | | | | |
| Ambient temperature range | °C –20 ... +50 (NBR seals) –15 ... +50 (FKM seals) | | | | | | |
| Storage temperature range | °C +5 ... +40 | | | | | | |
| Maximum storage time | Years 1 | | | | | | |
| Protection class according to EN 60529 | IP65 (if suitable and correctly mounted mating connectors are used) | | | | | | |
| Maximum admissible acceleration a_{\max} | g 10 | | | | | | |
| Surface protection | Galvanized | | | | | | |

| Hydraulic | |
|--|--|
| Maximum operating pressure | bar See table on page 8 |
| Hydraulic fluid | See table below |
| Hydraulic fluid temperature range ¹⁾ | °C –20 ... +80 (NBR seals) –15 ... +80 (FKM seals) |
| Viscosity range | mm ² /s 2.8 ... 500 |
| Maximum admissible degree of contamination of the hydraulic fluid Cleanliness class according to ISO 4406 (c) | Class 20/18/15 ²⁾ |
| Maximum flow | l/min 40 |

| Hydraulic fluid | Classification | Suitable sealing materials | Standards | Data sheet |
|-----------------|----------------------|----------------------------|-----------|------------|
| Mineral oils | HL, HLP, HLPD | FKM | DIN 51524 | 90220 |
| Bio-degradable | ▶ Insoluble in water | HETG | ISO 15380 | 90221 |
| | | HEES | | |
| | ▶ Soluble in water | HEPG | ISO 15380 | |

**Important information on hydraulic fluids:**

- ▶ For further information and data on the use of other hydraulic fluids, please refer to the data sheets above or contact us.
- ▶ There may be limitations regarding the technical valve data (temperature, pressure range, life cycle, maintenance intervals, etc.).
- ▶ The ignition temperature of the hydraulic fluid used must be 50 K higher than the maximum surface temperature.

- ▶ **Bio-degradable and flame-resistant – containing water:** If components with galvanic zinc coating (e.g. version "J3" or "J5") or parts containing zinc are used, small amounts of dissolved zinc may get into the hydraulic system and cause accelerated aging of the hydraulic fluid. Zinc soap may form as a chemical reaction product, which may clog filters, nozzles and solenoid valves – particularly in connection with local heat input.

¹⁾ Please observe the "Special application conditions for safe application" on page 7.

²⁾ The cleanliness classes specified for the components must be adhered to in hydraulic systems. Effective filtration prevents faults and at the same time increases the life cycle of the components.

Technical data

(For applications outside these values, please consult us!)

| Electrical | | | |
|---|---------------------------------------|-----|--|
| Supply voltage | ▶ Nominal value | VDC | 24 |
| | ▶ Voltage tolerance (nominal value) | % | ±10 |
| | ▶ Admissible residual ripple | % | <5 |
| | ▶ Maximum power consumption | W | 28.8 |
| | ▶ Nominal power according to VDE 0580 | W | 23 |
| Relative duty cycle time according to VDE 0580 | | | S1 (continuous operation) |
| Switching times according to ISO 6403 ³⁾ | ▶ ON | ms | 40 ... 80 |
| | ▶ OFF | ms | 10 ... 25 |
| Maximum switching frequency | | | 1/h 3600 |
| Maximum switch-off voltage peaks Solenoid | | | V 500, suitable damping by user required |

| Information on explosion protection – Directive 2014/34/EU | | |
|---|---------------------|-----------------------|
| Area of application | II 3G | II 3D |
| Type of protection of valve according to EN 80079-36 ⁴⁾ | Ex h IIC T3 Gc X | Ex h IIIC T140°C Dc X |
| Type of protection of solenoid coil according to EN 60079-7 / EN 60079-31 | Ex ec IIC T3 Gc | Ex tc IIIC T140°C Dc |
| Maximum surface temperature ⁵⁾ | °C 140 | |
| Temperature class | T3 | – |
| Type examination certificate solenoid | BVS 12 ATEX E 062 X | |

- ³⁾ The switching times were determined at a hydraulic fluid temperature of 40 °C and a viscosity of 46 cSt. Deviating hydraulic fluid temperatures can result in different switching times. Switching times change dependent on operating time and application conditions.
- ⁴⁾ Ex h: structural safety c according to EN 80079-37.
- ⁵⁾ Surface temperature > 50 °C, provide contact protection.

⚠ Special application conditions for safe application:

- ▶ A mating connector suitable for category 3G ("Gc") or 3D ("Dc") which ensures protection class IP65 in combination with the solenoid coil socket must be used.
- ▶ The valve is to be installed so that no impact stresses > 4 J can take effect.
- ▶ In order to avoid dangers caused by static charge, the base and/or subplate on which the valve is to be fitted must be electrically conductive and included in the equipotential bonding.
- ▶ Maximum admissible dust layer thickness 5 mm.
- ▶ Maximum hydraulic fluid temperature:
In case of bank assembly, as long as only one solenoid is energized at a time, and in case of individual assembly +80 °C.
In case of bank assembly when more than one solenoid is energized at a time +65 °C.
- ▶ The valve must be completely filled with hydraulic fluid.
- ▶ Ambient temperature range:
–20 ... +50 (NBR seals)
–15 ... +50 (FKM seals)

👉 Notice:

- ▶ Connection lines must be installed in a way that they are strain-relieved. The first mounting point must be within 150 mm of the mating connector.
- ▶ The valve solenoid must not be installed close to charge generating processes.
- ▶ The maximum temperature of the surface of the valve jacket is 110 °C. This has to be considered when selecting the connection cable and/or any contact of the connection cable with the surface of the jacket is to be prevented.
- ▶ The transfer temperature from the connector of the valve solenoid to the mating connector is 100 °C at an ambient temperature of 50 °C.

Performance limits(measured with HLP46, $\vartheta_{oil} = 40 \pm 5 \text{ } ^\circ\text{C}$)

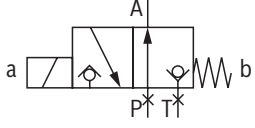
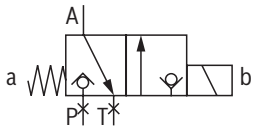
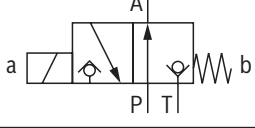
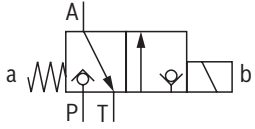
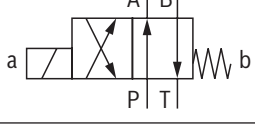
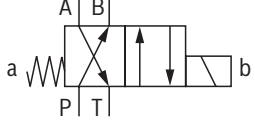
| | Symbol | Comment | Operating pressure in bar | | | | Flow in l/min |
|---|--|---|---------------------------|-----|-----|----------------------|---------------|
| | | | P | A | B | T | |
| 2-way circuit | UK  | With 2/2-way circuits, port P or T must be closed. $p_P \geq p_A \geq p_T$ | 350 | 350 | | 350 | 40 |
| | CK  | | 350 | 350 | | 350 | 40 |
| 3-way circuit | UK  | $p_P \geq p_A \geq p_T$ | 350 | 350 | | 350 | 40 |
| | CK  | | 350 | 350 | | 350 | 40 |
| 4-way circuit (flow only possible in the direction of arrow) | D  | 3/2 directional valve (symbol "UK") in connection with Plus-1 subplate: $p_P \geq p_A \geq p_B \geq p_T$ | 350 | 350 | 350 | $p_P/p_A/p_B$ -40 | 40 |
| | Y  | 3/2 directional valve (symbol "CK") in connection with Plus-1 subplate: $p_P \geq p_A \geq p_B \geq p_T$ | 350 | 350 | 350 | $p_P/p_A/p_B$ -40 | 40 |

Notice:

- ▶ Please see the project planning information on page 16.
- ▶ The performance limits were determined when the solenoids were at operating temperature, at 10 % undervoltage and without tank preloading.

Characteristic curves
(measured with HLP46, $\vartheta_{oil} = 40 \pm 5 \text{ }^\circ\text{C}$)

Δp - q_v characteristic curves
3/2 directional seat valve

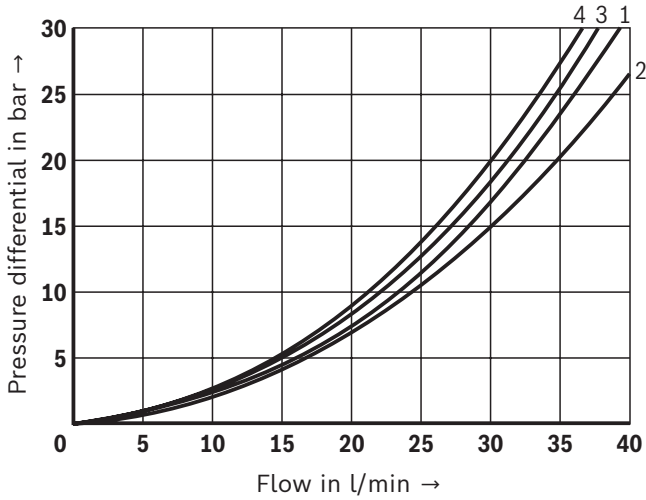

- 1 P→A (CK)
- 2 A→T (CK)
- 3 P→A (UK)
- 4 A→T (UK)

Δp - q_v characteristic curves
4/2 directional seat valve

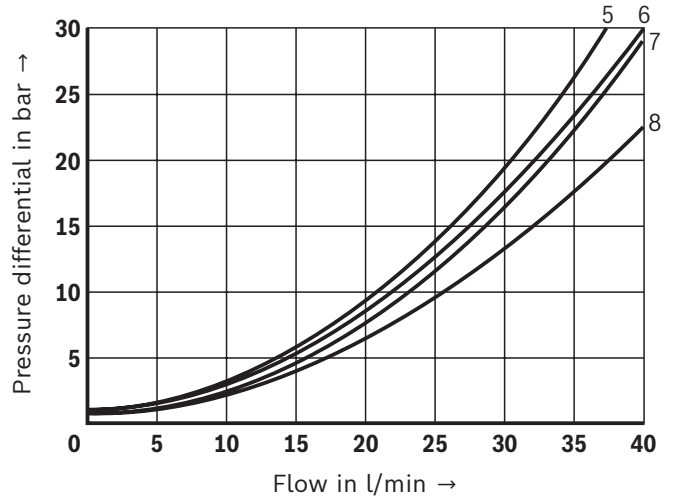

- 5 A→T
- 6 P→A
- 7 B→T
- 8 P→B

Δp - q_v characteristic curves
Check valve insert

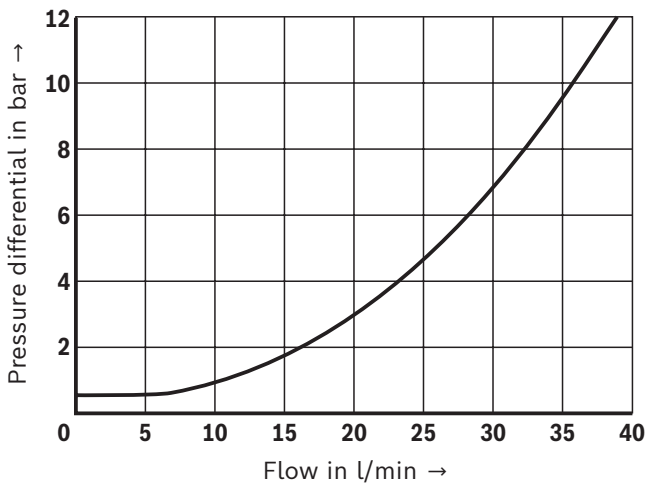

Δp - q_v characteristic curves
Throttle insert

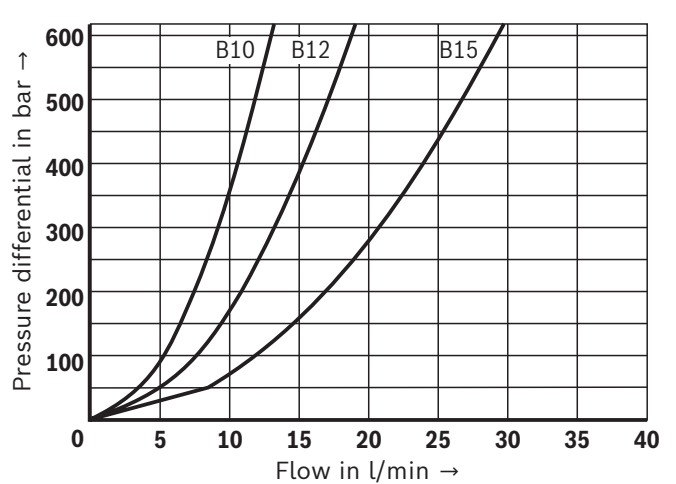

Dimensions: 3/2 directional seat valve – version "UK"
(dimensions in mm)

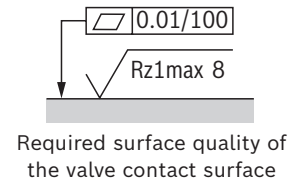
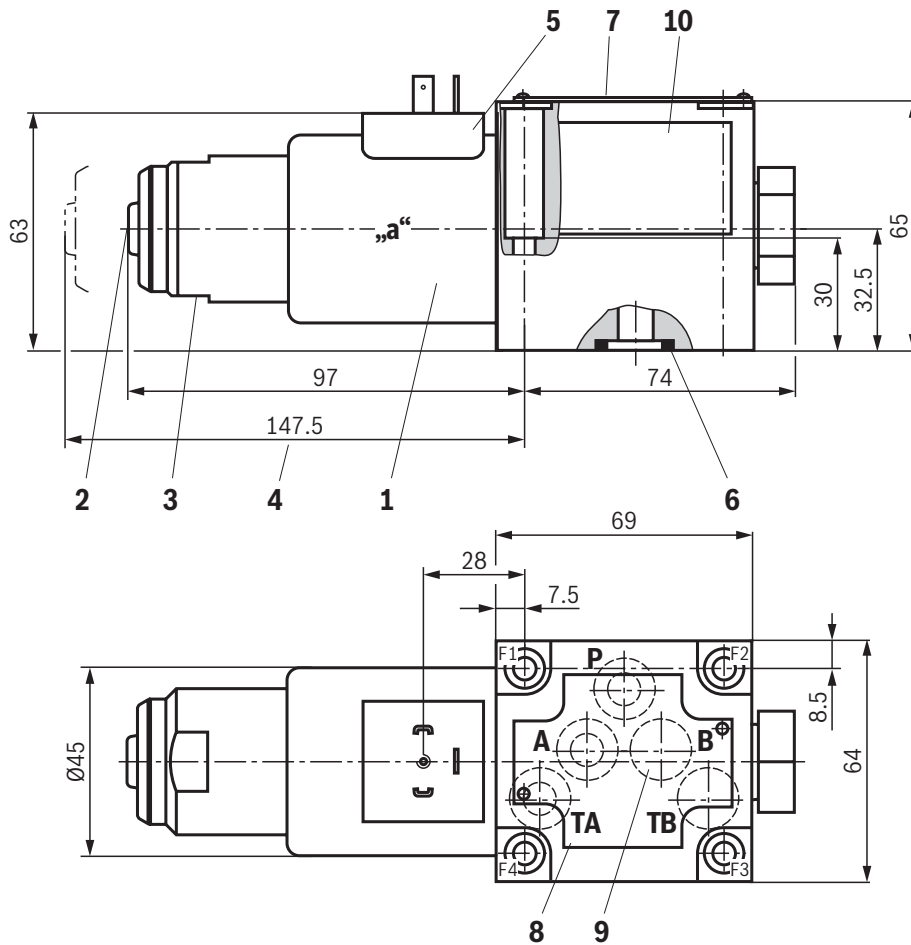

- 1 Solenoid coil
- 2 Concealed manual override "N9"
- 3 Mounting nut with double edge, wrench size 32
- 4 Space required to remove the solenoid coil
- 5 Plug-in connector according to EN 175301-803, design A
- 6 Identical seal rings for ports A, B, T, seal ring for port P
- 7 Name plate
- 8 Porting pattern according to ISO 4401-05-04-0-05
- 9 Ports B and TB are designed as blind counterbore
- 10 Name plate sticker

Valve mounting screws (separate order)

Only use valve mounting screws with the subsequently listed thread diameters and strength properties. Observe the screw-in depth.

4 hexagon socket head cap screws

ISO 4762 - M6 x 40 - 10.9

(friction coefficient $\mu_{\text{total}} = 0.09 \dots 0.14$);

Tightening torque $M_A = 12.5 \text{ Nm} \pm 10 \%$,

Material no. **R913051533**

Subplates (separate order) with porting pattern according to ISO 4401-05-04-0-05, see data sheet 45100.

Notice:

- ▶ Subplates are no components in the sense of Directive 2014/34/EU and can be used after the manufacturer of the overall system has conducted an assessment of the risk of ignition. The "G...J3" versions are free from aluminum and/or magnesium and galvanized.
- ▶ Deviating from ISO 4401, port T is called TA and port T1 is called TB in this data sheet.
- ▶ The dimensions are nominal dimensions which are subject to tolerances.

Dimensions: 3/2 directional seat valve – version "CK"
(dimensions in mm)

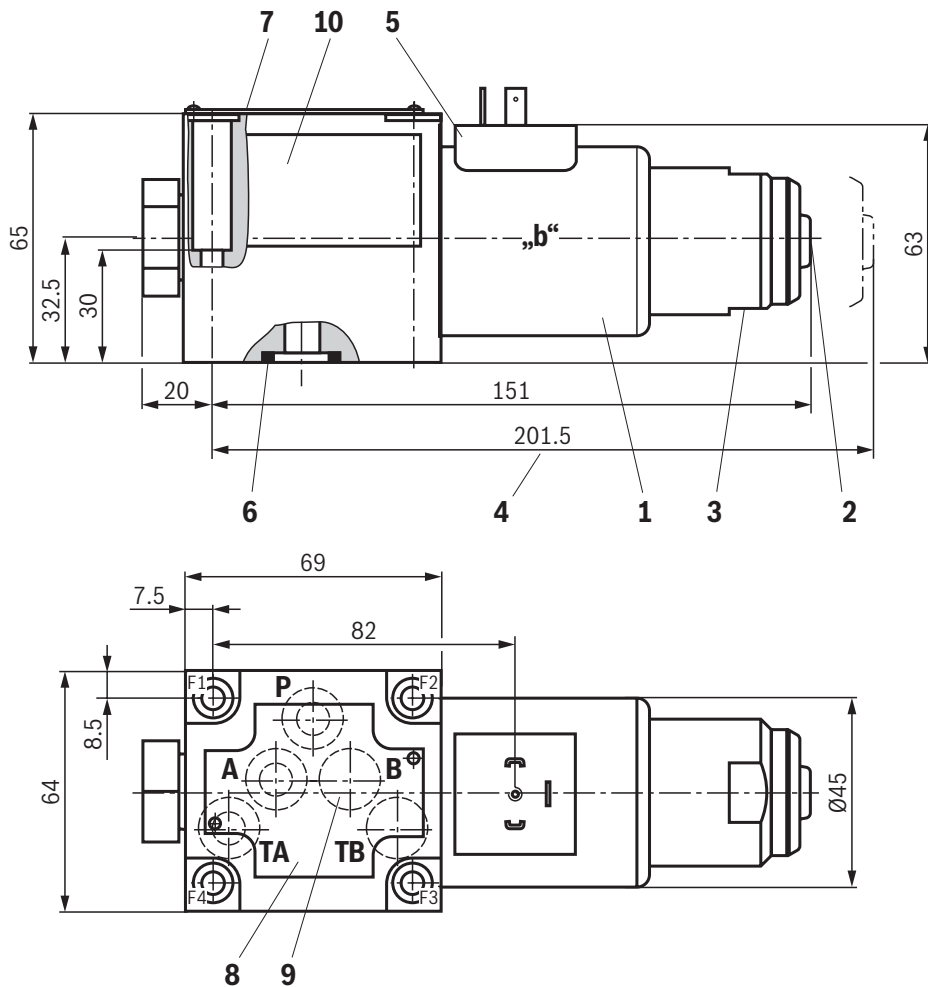

Required surface quality of the valve contact surface

- 1 Solenoid coil
- 2 Concealed manual override "N9"
- 3 Mounting nut with double edge, wrench size 32
- 4 Space required to remove the solenoid coil
- 5 Plug-in connector according to EN 175301-803, design A
- 6 Identical seal rings for ports A, B, T, seal ring for port P
- 7 Name plate
- 8 Porting pattern according to ISO 4401-05-04-0-05
- 9 Ports B and TB are designed as blind counterbore
- 10 Name plate sticker

Valve mounting screws (separate order)

Only use valve mounting screws with the subsequently listed thread diameters and strength properties. Observe the screw-in depth.

4 hexagon socket head cap screws

ISO 4762 - M6 x 40 - 10.9

(friction coefficient $\mu_{\text{total}} = 0.09 \dots 0.14$);

Tightening torque $M_A = 12.5 \text{ Nm} \pm 10 \%$,

Material no. **R913051533**

Subplates (separate order) with porting pattern according to ISO 4401-05-04-0-05, see data sheet 45100.

Notice:

- ▶ Subplates are no components in the sense of Directive 2014/34/EU and can be used after the manufacturer of the overall system has conducted an assessment of the risk of ignition. The "G...J3" versions are free from aluminum and/or magnesium and galvanized.
- ▶ Deviating from ISO 4401, port T is called TA and port T1 is called TB in this data sheet.
- ▶ The dimensions are nominal dimensions which are subject to tolerances.

Dimensions: 4/2 directional seat valve – version "D"
(dimensions in mm)

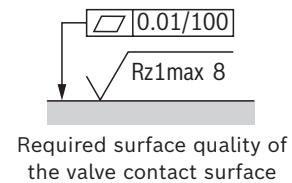
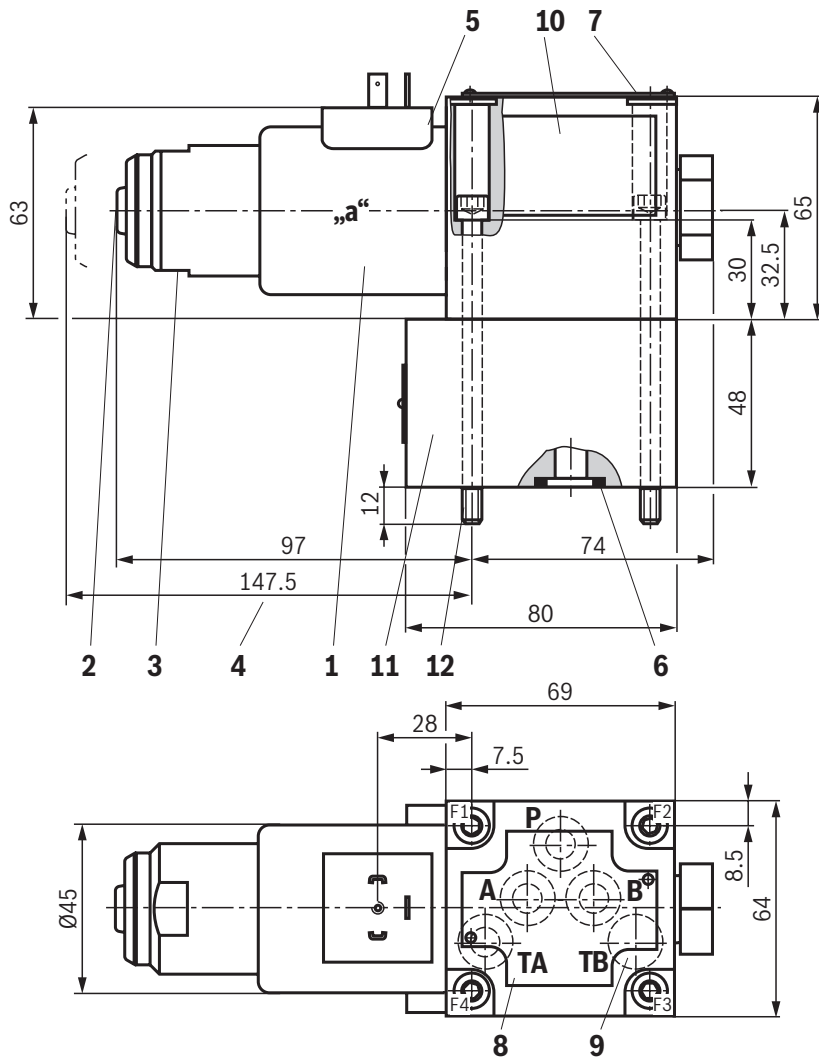

- 1 Solenoid coil
- 2 Concealed manual override "N9"
- 3 Mounting nut with double edge, wrench size 32
- 4 Space required to remove the solenoid coil
- 5 Plug-in connector according to EN 175301-803, design A
- 6 Identical seal rings for ports A, B, T, seal ring for port P
- 7 Name plate
- 8 Porting pattern according to ISO 4401-05-04-0-05
- 9 Port TB is designed as blind counterbore
- 10 Name plate sticker
- 11 Plus-1 subplate
- 12 Valve mounting screws

Valve mounting screws (included in the scope of delivery)

4 hexagon socket head cap screws

ISO 4762 - M6 x 90 - 10.9

(friction coefficient $\mu_{\text{total}} = 0.09 \dots 0.14$);

Tightening torque $M_A = 12.5 \text{ Nm} \pm 10 \%$,

Material no. **R913048089**

Subplates (separate order) with porting pattern according to ISO 4401-05-04-0-05, see data sheet 45100.

Notice:

- ▶ Subplates are no components in the sense of Directive 2014/34/EU and can be used after the manufacturer of the overall system has conducted an assessment of the risk of ignition. The "G...J3" versions are free from aluminum and/or magnesium and galvanized.
- ▶ Deviating from ISO 4401, port T is called TA and port T1 is called TB in this data sheet.
- ▶ The dimensions are nominal dimensions which are subject to tolerances.

Dimensions: 4/2 directional seat valve – version "Y"
(dimensions in mm)

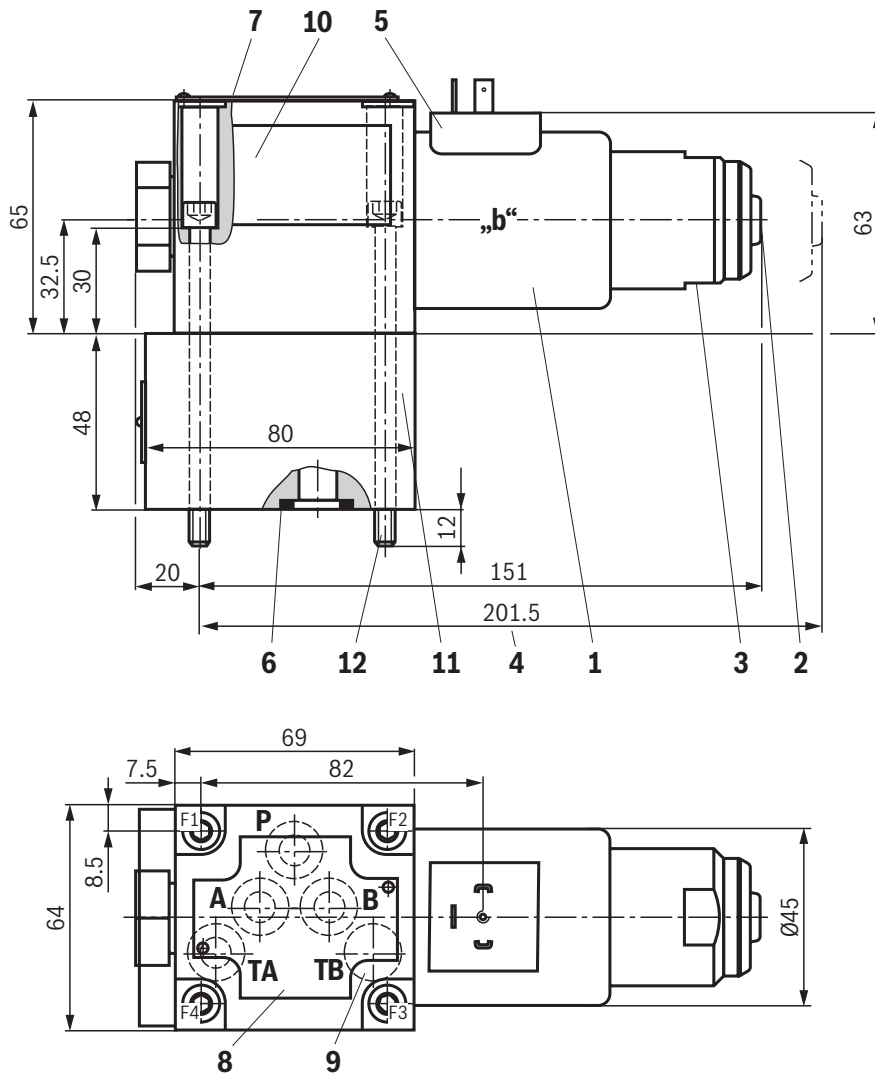

- 1 Solenoid coil
- 2 Concealed manual override "N9"
- 3 Mounting nut with double edge, wrench size 32
- 4 Space required to remove the solenoid coil
- 5 Plug-in connector according to EN 175301-803, design A
- 6 Identical seal rings for ports A, B, T, seal ring for port P
- 7 Name plate
- 8 Porting pattern according to ISO 4401-05-04-0-05
- 9 Port TB is designed as blind counterbore
- 10 Name plate sticker
- 11 Plus-1 subplate
- 12 Valve mounting screws

Valve mounting screws (included in the scope of delivery)

4 hexagon socket head cap screws

ISO 4762 - M6 x 90 - 10.9

(friction coefficient $\mu_{\text{total}} = 0.09 \dots 0.14$);

Tightening torque $M_A = 12.5 \text{ Nm} \pm 10 \%$,

Material no. **R913048089**

Subplates (separate order) with porting pattern according to ISO 4401-05-04-0-05, see data sheet 45100.

Notice:

- ▶ Subplates are no components in the sense of Directive 2014/34/EU and can be used after the manufacturer of the overall system has conducted an assessment of the risk of ignition. The "G...J3" versions are free from aluminum and/or magnesium and galvanized.
- ▶ Deviating from ISO 4401, port T is called TA and port T1 is called TB in this data sheet.
- ▶ The dimensions are nominal dimensions which are subject to tolerances.

Installation conditions (dimensions in mm)

| | Individual assembly | Bank assembly |
|--|--|---|
| Subplate dimensions | Minimum dimensions Length ≥ 100 , width ≥ 70 , height ≥ 32 | Minimum cross-section Height ≥ 60 , width ≥ 85 |
| Thermal conductivity of the subplate | ≥ 36.2 W/mK | |
| Minimum distance between the longitudinal valve axes | ≥ 73 | |

Individual assembly

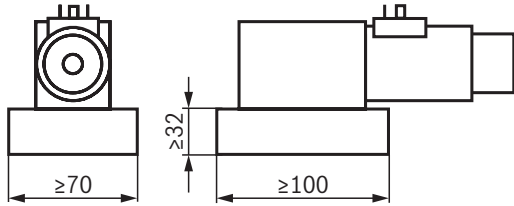

Bank assembly

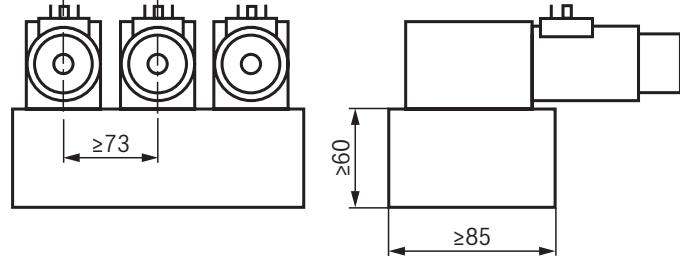

Notice:

Observe the "Special application conditions for safe application" on page 7 with regard to the hydraulic fluid temperature.

Throttle insert

The use of a throttle insert is required when, due to prevailing operating conditions, flows can occur during the switching processes, which exceed the performance limit of the valve.

Examples:

- ▶ Accumulator operation,
- ▶ Use as pilot control valve with internal pilot fluid tapping.

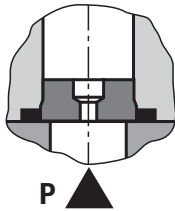

Check valve insert

The check valve insert allows a free flow from P to A and closes A to P.

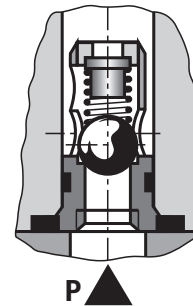

Electrical connection

The type-examination tested valve solenoid of the valve is equipped with an electrical connection according to the following table. The electrical connection of the solenoid is polarity-independent.

Electrical connections and coil connection combinations

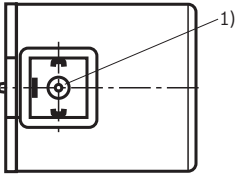
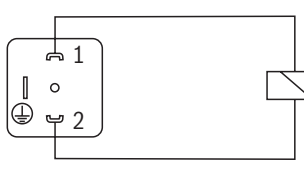
| Connector ordering code | Top view | Circuit diagram | Pin | Connections, assignment |
|---|---|--|-------------|--|
| 3-pole connector (2+PE) according to EN 175301-803 (IP65) |  |  | 1 2 ⊕ | Solenoid coil, polarity-independent Grounding |

1) M3, maximum tightening torque $M_{A \max} = 1 \text{ Nm}$

Requirement for cable sets and mating connectors

| | | |
|--|-----------------|----------------|
| Temperature rating (cables, connectors, seals) | °C | ≤-30 ... ≥+100 |
| Minimum wire cross-section | mm ² | 0.75 |
| Protection class according to EN 60529 | | IP65 |

Notice:

All three contacts of the solenoid coil (1, 2 and grounding) must be properly connected (3-wire line).

Over-current fuse and switch-off voltage peaks

| Voltage data in the valve type code | Nominal voltage valve solenoid | Rated current valve solenoid | Recommended back-up fuse characteristics medium time-lag according to EN 60127-1 |
|-------------------------------------|--------------------------------|------------------------------|--|
| G24 | 24 VDC | 0.95 ADC | 1 A |

Notice:

A fuse which corresponds to the rated current according to DIN 41571 and EN / IEC 60127 has to be connected upstream of every valve solenoid (max. $3 \times I_{\text{rated}}$).
The shut-off threshold of the fuse has to match the prospective short-circuit current of the supply source.
The prospective short-circuit current of the supply source may amount to a maximum of 1500 A.

This fuse may only be installed outside the potentially explosive atmospheres or must be of an explosion-proof design.
When inductivities are switched off, voltage peaks result which may cause faults in the connected control electronics.
The voltage peak must be damped by a suitable external circuitry.
We recommend a circuitry with a suppressor diode with a limitation voltage of approx. 50 V.

Project planning information

Seat valves can be used according to the symbols as well as the assigned operating pressures and flows (see performance limits, page 8).

In order to ensure safe functioning, it is absolutely necessary to observe the following:

- ▶ Seat valves have a negative spool overlap, i.e. during the switching process, there is leakage oil. However, this process takes place within such a short time that it is irrelevant in nearly all applications.
- ▶ The specified maximum flow must not be exceeded (use a throttle insert for flow limitation, if necessary).

Plus-1 subplate:

- ▶ If the Plus-1 subplate (4/2 directional function) is used, the following lower operating values have to be observed:
 $p_{\min} = 8 \text{ bar}$, $q_v > 3 \text{ l/min}$.
- ▶ Ports P, A, B and T are clearly specified according to their tasks. They must not be exchanged or closed.
- ▶ Port T must always be connected.
- ▶ Observe the pressure level and pressure distribution.
- ▶ The flow is only permitted in the direction of arrow.

Further information

- | | |
|---|--|
| ▶ Subplates | Data sheet 45100 |
| ▶ Use of non-electrical hydraulic components in an explosive environment (ATEX) | Data sheet 07011 |
| ▶ Hydraulic fluids on mineral oil basis | Data sheet 90220 |
| ▶ Environmentally compatible hydraulic fluids | Data sheet 90221 |
| ▶ Hydraulic valves...XN... | Operating instructions 22106-XN-B |
| ▶ Information on available spares | www.boschrexroth.com/spc |

Bosch Rexroth AG
 Industrial Hydraulics
 Zum Eisengießer 1
 97816 Lohr am Main, Germany
 Phone +49 (0) 93 52/ 40 30 20
my.support@boschrexroth.com
www.boschrexroth.com

© All rights reserved to Bosch Rexroth AG, also regarding any disposal, exploitation, reproduction, editing, distribution, as well as in the event of applications for industrial property rights.
 The data specified above only serve to describe the product. As our products are constantly being further developed, no statements concerning a certain condition or suitability for a certain application can be derived from our information. The information given does not release the user from the obligation of own judgment and verification.
 It must be remembered that our products are subject to a natural process of wear and aging.