

Rexroth IndraDrive ML

Universal Inverters HMU05

Instruction Manual
R911345961

Edition 03



Title Rexroth IndraDrive ML
Universal Inverters HMU05

Type of Documentation Instruction Manual

Document Typecode DOK-INDRV*-HXX05*UL***-IN03-EN-P

Internal File Reference RS-843cd7255923628e0a6846a501c1cc25-3-en-US-3

Record of Revision

Edition	Release Date	Notes
01	2014-12	First edition
02	2015-11	Revised edition
03	2017-01	Revised edition

Purpose of Documentation This documentation provides information on the installation and operation of the described products, by persons trained and qualified to work with electrical installations.

Copyright © Bosch Rexroth AG 2017

This document, as well as the data, specifications and other information set forth in it, are the exclusive property of Bosch Rexroth AG. It may not be reproduced or given to third parties without its consent.

Liability The specified data is intended for product description purposes only and shall not be deemed to be a guaranteed characteristic unless expressly stipulated in the contract. All rights are reserved with respect to the content of this documentation and the availability of the product.

Table of Contents

	Page
1	Important notes..... 3
1.1	Safety instructions..... 3
1.1.1	General information..... 3
1.1.2	Protection against contact with electrical parts and housings..... 4
1.1.3	Battery safety..... 5
1.2	Appropriate use..... 6
2	Ratings and dimensions..... 7
2.1	HMU05 ratings (operated as drive controller)..... 7
2.2	HMU05 ratings (operated as supply unit)..... 9
2.3	Dimensions..... 11
2.3.1	HMU05.1N-F0140-0350..... 11
2.3.2	HMU05.1N-F0170-0430..... 12
2.3.3	HMU05.1N-F0220-0510..... 13
2.3.4	HMU05.1N-F0270-0660..... 14
2.3.5	HMU05.1N-F0340-0820..... 15
2.3.6	HMU05.1N-F0430-1040..... 16
2.3.7	HMU05.1N-F0540-1300..... 17
2.4	HNA05 ratings..... 18
2.5	HLT05 ratings..... 21
3	Instructions for use..... 25
3.1	Mounting HMU05 devices in control cabinet..... 25
3.2	Overcurrent protection..... 25
3.3	Short circuit protection..... 25
3.4	Overload protection..... 25
3.5	Connection diagrams..... 25
3.5.1	Overall connection diagram (HMU05 as supply unit)..... 25
	Overall connection diagram with load contactor..... 25
	Overall connection diagram with a controllable main switch..... 27
3.5.2	Overall connection diagram (HMU05 as drive controller)..... 29
3.5.3	HLT05 connection diagram (braking unit)..... 30
3.6	Connection points..... 32
3.6.1	HMU05 connection points..... 32
3.6.2	HNA05 connection points..... 34
3.6.3	HLT05 connection points..... 35
4	Service and support..... 37
	Index..... 39

1 Important notes

1.1 Safety instructions

1.1.1 General information

- Do not attempt to install and operate the components of the electric drive and control system without first reading all documentation provided with the product. Read and understand these safety instructions and all user documentation prior to working with these components. If you do not have the user documentation for the components, contact our Rexroth sales representative. Ask for these documents to be sent immediately to the person or persons responsible for the safe operation of the components.
- If the supplied documents contain some information you do not understand, it is absolutely necessary that you ask Rexroth for explanation before you start working at or with the components.
- If the component is resold, rented and/or passed on to others in any other form, these safety instructions must be delivered with the component in the official language of the user's country.
- Only qualified persons may work with components of the electric drive and control system or within its proximity.

In terms of this Instruction Manual, qualified persons are those persons who are familiar with the installation, mounting, commissioning and operation of the components of the electric drive and control system, as well as with the hazards this implies, and who possess the qualifications their work requires. To comply with these qualifications, it is necessary, among other things,

- to be trained, instructed or authorized to switch electric circuits and components safely on and off, to ground them and to mark them,
- to be trained or instructed to maintain and use adequate safety equipment,
- to attend a course of instruction in first aid.
- The technical data, connection and installation conditions of the components are specified in the respective application documentations and must be followed at all times.
- If the components take the form of hardware, then they must remain in their original state, in other words, no structural changes are permitted. It is not permitted to decompile software components or alter source codes.
- Do not mount damaged or faulty components or use them in operation.
- Only use accessories and spare parts approved by Rexroth.
- Follow the safety regulations and requirements of the country in which the electric components of the electric drive and control system are operated.
- Proper and correct transport, storage, mounting and installation, as well as care in operation and maintenance, are prerequisites for optimal and safe operation of the component.

Improper use of these components, failure to follow the safety instructions in this document or tampering with the product, including disabling of safety devices, could result in property damage, injury, electric shock or even death.

Important notes

1.1.2 Protection against contact with electrical parts and housings



This section concerns components of the electric drive and control system with voltages of **more than 50 volts**.

Contact with parts conducting voltages above 50 volts can cause personal danger and electric shock. When operating components of the electric drive and control system, it is unavoidable that some parts of these components conduct dangerous voltage.

High electrical voltage! Danger to life, risk of injury by electric shock or serious injury!

- Only qualified persons are allowed to operate, maintain and/or repair the components of the electric drive and control system.
- Follow the general installation and safety regulations when working on power installations.
- Before switching on, the equipment grounding conductor must have been permanently connected to all electric components in accordance with the connection diagram.
- Even for brief measurements or tests, operation is only allowed if the equipment grounding conductor has been permanently connected to the points of the components provided for this purpose.
- Before accessing electrical parts with voltage potentials higher than 50 V, you must disconnect electric components from the mains or from the power supply unit. Secure the electric component from reconnection.
- With electric components, observe the following aspects:
 - Always wait **30 minutes** after switching off power to allow live capacitors to discharge before accessing an electric component. Measure the electrical voltage of live parts before beginning to work to make sure that the equipment is safe to touch.
- Install the covers and guards provided for this purpose before switching on.
- Never touch electrical connection points of the components while power is turned on.
- Do not remove or plug in connectors when the component has been powered.
- Under specific conditions, electric drive systems can be operated at mains protected by residual-current-operated circuit-breakers sensitive to universal current (RCDs/RCMs).
- Secure built-in devices from penetrating foreign objects and water, as well as from direct contact, by providing an external housing, for example a control cabinet.

High housing voltage and high leakage current! Danger to life, risk of injury by electric shock!

- Before switching on and before commissioning, ground or connect the components of the electric drive and control system to the equipment grounding conductor at the grounding points.

Important notes

- Connect the equipment grounding conductor of the components of the electric drive and control system permanently to the main power supply at all times. The leakage current is greater than 3.5 mA.
- Establish an equipment grounding connection with a minimum cross section according to the table below. With an outer conductor cross section smaller than 10 mm² (8 AWG), the alternative connection of two equipment grounding conductors is allowed, each having the same cross section as the outer conductors.

Cross section outer conductor	Minimum cross section equipment grounding conductor Leakage current ≥ 3.5 mA	
	1 equipment grounding conductor	2 equipment grounding conductors
1.5 mm ² (16 AWG)	10 mm ² (8 AWG)	2 × 1.5 mm ² (16 AWG)
2.5 mm ² (14 AWG)		2 × 2.5 mm ² (14 AWG)
4 mm ² (12 AWG)		2 × 4 mm ² (12 AWG)
6 mm ² (10 AWG)		2 × 6 mm ² (10 AWG)
10 mm ² (8 AWG)		-
16 mm ² (6 AWG)	16 mm ² (6 AWG)	-
25 mm ² (4 AWG)		-
35 mm ² (2 AWG)		-
50 mm ² (1/0 AWG)	25 mm ² (4 AWG)	-
70 mm ² (2/0 AWG)	35 mm ² (2 AWG)	-
X mm ²	(X × 0.5) mm ² (applies to X ≥ 50)	-

Tab. 1-1: Minimum cross section of the equipment grounding connection

1.1.3 Battery safety

Batteries consist of active chemicals in a solid housing. Therefore, improper handling can cause injury or property damage.

Risk of injury by improper handling!

- Do not attempt to reactivate low batteries by heating or other methods (risk of explosion and cauterization).
- Do not attempt to recharge the batteries as this may cause leakage or explosion.
- Do not throw batteries into open flames.
- Do not dismantle batteries.
- When replacing the battery/batteries, do not damage the electrical parts installed in the devices.
- Only use the battery types specified for the product.

Important notes



Environmental protection and disposal! The batteries contained in the product are considered dangerous goods during land, air, and sea transport (risk of explosion) in the sense of the legal regulations. Dispose of used batteries separately from other waste. Observe the national regulations of your country.

1.2 Appropriate use

This product may only be used for the mentioned applications under the specified application, ambient and operating conditions.

This product is exclusively intended for use in machines and systems in an industrial environment. This is to be understood as applications according to IEC 60204-1 "Safety of machinery, Electric equipment of machines" and NFPA 79 "Electrical Standard for Industrial Machinery".



Components of the Rexroth IndraDrive ML system with a mains input current **< 400 A** are **products of Category C3** (with restricted distribution) in accordance with IEC 61800-3. The Category C3 comprises EMC limit values for line-based and radiated noise emission.

Components of the Rexroth IndraDrive ML system with a mains input current **> 400 A** are **products of Category C4** (with restricted distribution) in accordance with IEC 61800-3. The Category C4 comprises an EMC plan developed by manufacturers and users.

Compliance with these Categories requires the appropriate measures of interference suppression (e.g., mains filters, shielding measures) to be used in the drive system.

These components are not provided for use in a public low-voltage mains supplying residential areas. If these components are used in such a mains, high-frequency interference is to be expected. This can require additional measures of interference suppression.

The components are not provided for use in a mains with grounded outer conductor (corner-grounded delta mains).

The component source shall be derived from a non-corner grounded type TN AC source not exceeding 289 V phase to earth.

2 Ratings and dimensions

2.1 HMU05 ratings (operated as drive controller)

UL ratings and dimensions

Description	Symbol	Unit	HMU05.1N-...						
			F0140-0350	F0170-0430	F0220-0510	F0270-0660	F0340-0820	F0430-1040	F0540-1300
Listing in accordance with UL standard			UL 61800-5-1						
Listing in accordance with CSA standard			CSA C22.2 No.274-13						
UL files			E134201						
Overvoltage category			III (in accordance with IEC 60664-1)						
Pollution degree			2						
Maximum surrounding air temperature	T_{amax}	°C	40						
Maximum surrounding air temperature with reduced nominal data	T_{amax_red}	°C	55						
Mass	m	kg	51	58	65	70	83	103	
Device height ¹⁾	H	mm	817	921	1025	1103	1311	1522	
Device depth ²⁾	T	mm	440						
Device width ³⁾	B	mm	200						220
Minimum distance on the top of the device ⁴⁾	d_{top}	mm	100						
Minimum distance on the bottom of the device ⁵⁾	d_{bot}	mm	100						
Horizontal spacing on the device ⁶⁾	d_{hor}	mm	0						
Rated control voltage input ⁷⁾	U_{N3}	V	24 ±20%; 1.9 A						
Rated power consumption control voltage input at U_{N3} ⁸⁾	P_{N3}	W	65	48	53	46	48	56	58
Holding brake output voltage	U_{Br}	V	DC 24						
Holding brake output current	I_{Br}	A	2						
Short circuit current rating	SCCR	A rms	85000						
Rated input voltage, power	U_{LN_nom}	V	DC 450 ... 750						
Rated input current	I_{LN}	A	242	291	373	467	587	734	954
Field wiring material (material; conductor temperature; class)			Cu; 60/75 °C; 1						
Output voltage	U_{out}	V	3 × AC 0 ... 500						

Ratings and dimensions

Description	Symbol	Unit	HMU05.1N-...						
			F0140-0350	F0170-0430	F0220-0510	F0270-0660	F0340-0820	F0430-1040	F0540-1300
Output current	I_{out}	A	254	306	392	490	616	771	1002
Output frequency range ⁹⁾	f_{out}	Hz	0 ... 1600						
Power dissipation at continuous current and continuous DC bus power respectively ¹⁰⁾	P_{Diss_cont}	W	2500	3000	4250	5500		6500	8700
Cooling liquid: Minimum flow rate		l/min	4.5	5.4	7.3	9.2	9.0	11.4	15.8
Cooling liquid: Rated operating pressure		bar	2.0						
Cooling liquid: Maximum inlet temperature		°C	60						

- 1) 2) 3) Housing dimension; see also related dimensional drawing
 4) 5) 6) See fig. "Air intake and air outlet at device"
 7) Observe supply voltage for motor holding brakes
 8) Plus motor holding brake and control section; plus power consumption of externally connected inputs/outputs, plus safety option
 9) Depending on switching frequency which was set in parameter P-0-0001
 10) Plus dissipation of braking resistor and control section

Tab. 2-1: HMU - UL ratings and dimensions

Distances

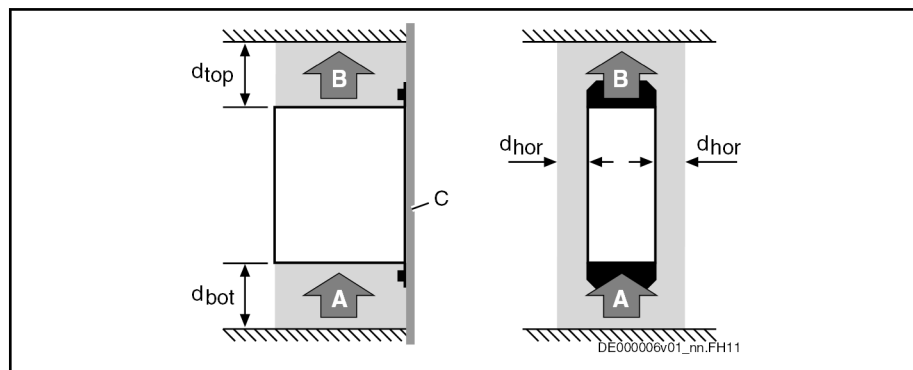

- A Air intake
 B Air outlet
 C Mounting surface in control cabinet
 d_{top} Distance top
 d_{bot} Distance bottom
 d_{hor} Distance horizontal

Fig. 2-1: Air intake and air outlet at device

2.2 HMU05 ratings (operated as supply unit)

UL ratings and dimensions

Description	Symbol	Unit	HMU05.1N-...						
			F0140-0350	F0170-0430	F0220-0510	F0270-0660	F0340-0820	F0430-1040	F0540-1300
Listing in accordance with UL standard			UL 61800-5-1						
Listing in accordance with CSA standard			CSA C22.2 No.274-13						
UL files			E134201						
Overvoltage category			III (in accordance with IEC 60664-1)						
Pollution degree			2						
Maximum surrounding air temperature	T_{amax}	°C	40						
Maximum surrounding air temperature with reduced nominal data	T_{amax_red}	°C	55						
Mass	m	kg	51	58	65	70	83	103	
Device height ¹⁾	H	mm	817	921	1025	1103	1311	1522	
Device depth ²⁾	T	mm	440						
Device width ³⁾	B	mm	200					220	
Minimum distance on the top of the device ⁴⁾	d_{top}	mm	100						
Minimum distance on the bottom of the device ⁵⁾	d_{bot}	mm	100						
Horizontal spacing on the device ⁶⁾	d_{hor}	mm	0						
Control voltage input	U_{N3}	V	24 ±20%; 1.9 A						
Rated power consumption control voltage input at U_{N3} ⁷⁾	P_{N3}	W	65	48	53	46	48	56	58
Short circuit current rating	SCCR	A rms	85000						
Rated input voltage, power supply ⁸⁾	U_{LN_nom}	V	3 × AC 380 ... 500						
Tolerance rated input voltage U_{LN}		%	+10 / -15						
Mains frequency	f_{LN}	Hz	50 ... 60						
Mains frequency tolerance		Hz	-2						
Rated input current	I_{LN}	A	218	262	327	409	514	652	811
Branch circuit protection fuse ⁹⁾			LPJ 300SP	LPJ 350SP	LPJ 450SP	LPJ 600SP	KRP- C700SP	KRP- C900SP	KRP- C1200SP

Ratings and dimensions

Description	Symbol	Unit	HMU05.1N-...						
			F0140-0350	F0170-0430	F0220-0510	F0270-0660	F0340-0820	F0430-1040	F0540-1300
Field wiring material (material; conductor temperature; class)			Cu; 60/75 °C; 1						
Output voltage	U_{out}	V	DC 750						
Output power	P_{out}	kW	144	173	216	270	340	430	540
Power dissipation at continuous current and continuous DC bus power respectively ¹⁰⁾	P_{Diss_cont}	W	2500	3000	4250	5500		6500	8700
Cooling liquid: Minimum flow rate		l/min	4.5	5.4	7.3	9.2	9.0	11.4	15.8
Cooling liquid: Rated operating pressure		bar	2.0						
Cooling liquid: Maximum inlet temperature		°C	60						

- 1) 2) 3) Housing dimension; see also related dimensional drawing
- 4) 5) 6) See fig. "Air intake and air outlet at device"
- 7) Plus control section; plus power consumption of externally connected inputs/outputs, plus safety option
- 8) Mains input L1, L2, L3; the source shall be derived from a non-corner grounded type TN AC source not exceeding 289 V phase to earth
- 9) Use listed AC input line fuses by Cooper Bussmann
- 10) Plus dissipation of braking resistor and control section

Tab. 2-2: HMU - UL ratings and dimensions

Distances

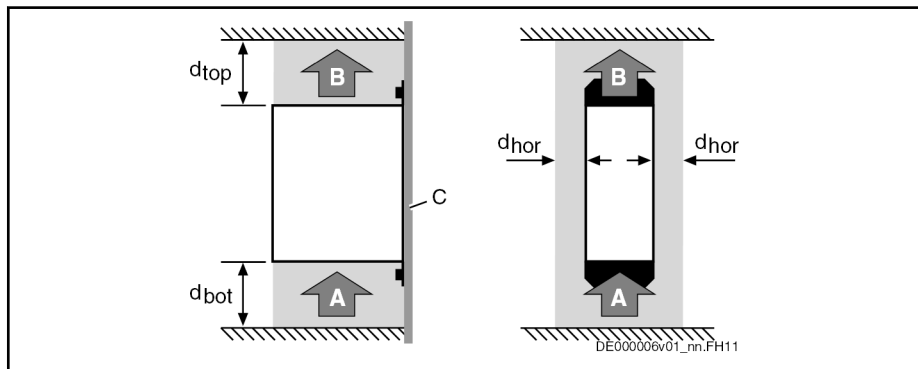

- A Air intake
- B Air outlet
- C Mounting surface in control cabinet
- d_{top} Distance top
- d_{bot} Distance bottom
- d_{hor} Distance horizontal

Fig. 2-2: Air intake and air outlet at device

Ratings and dimensions

2.3.2 HMU05.1N-F0170-0430

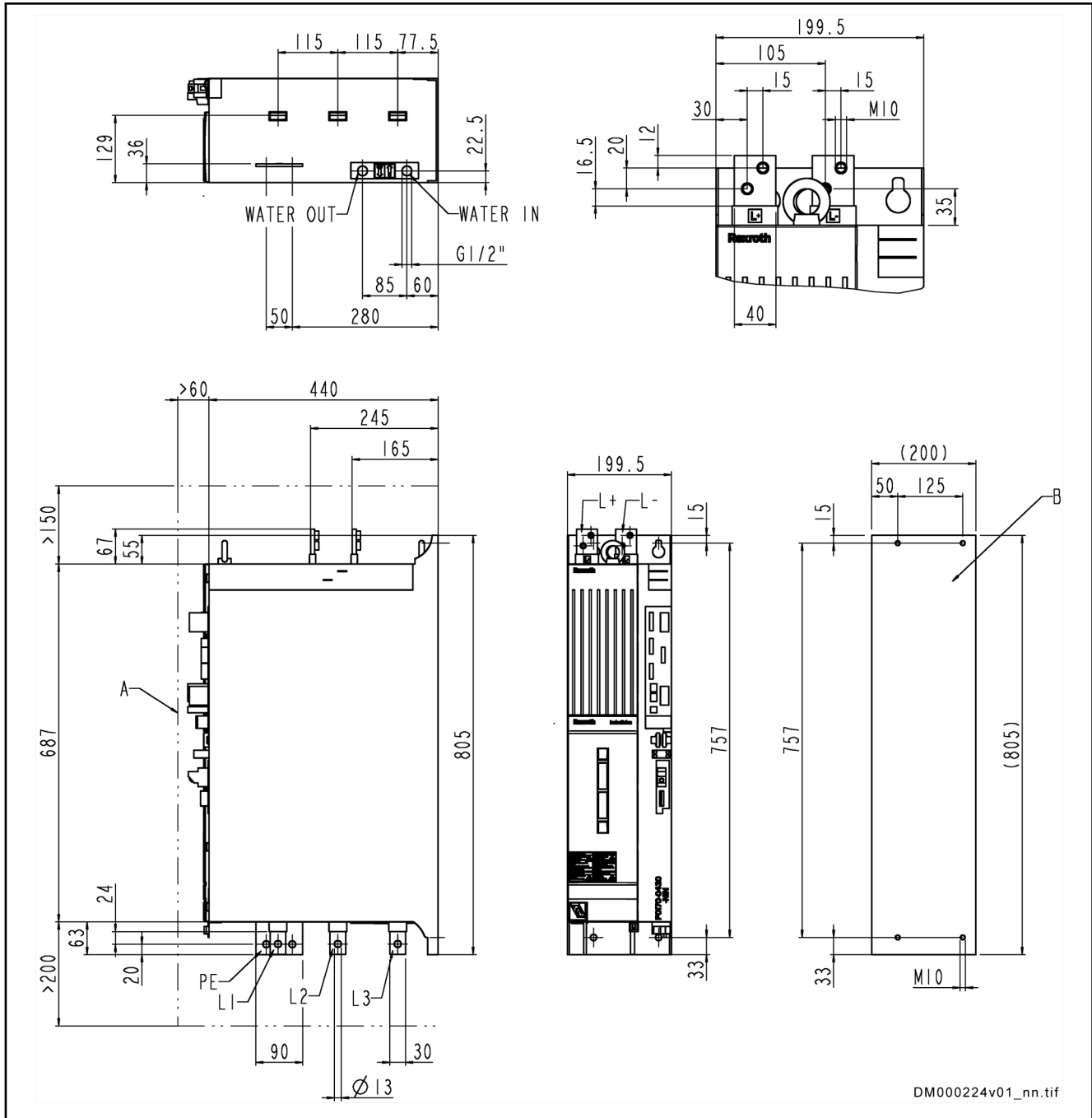

DM000224v01_nn.tif

A Minimum mounting clearance
B Boring dimensions
Fig. 2-4: HMU05.1N-F0170-0430

2.3.3 HMU05.1N-F0220-0510

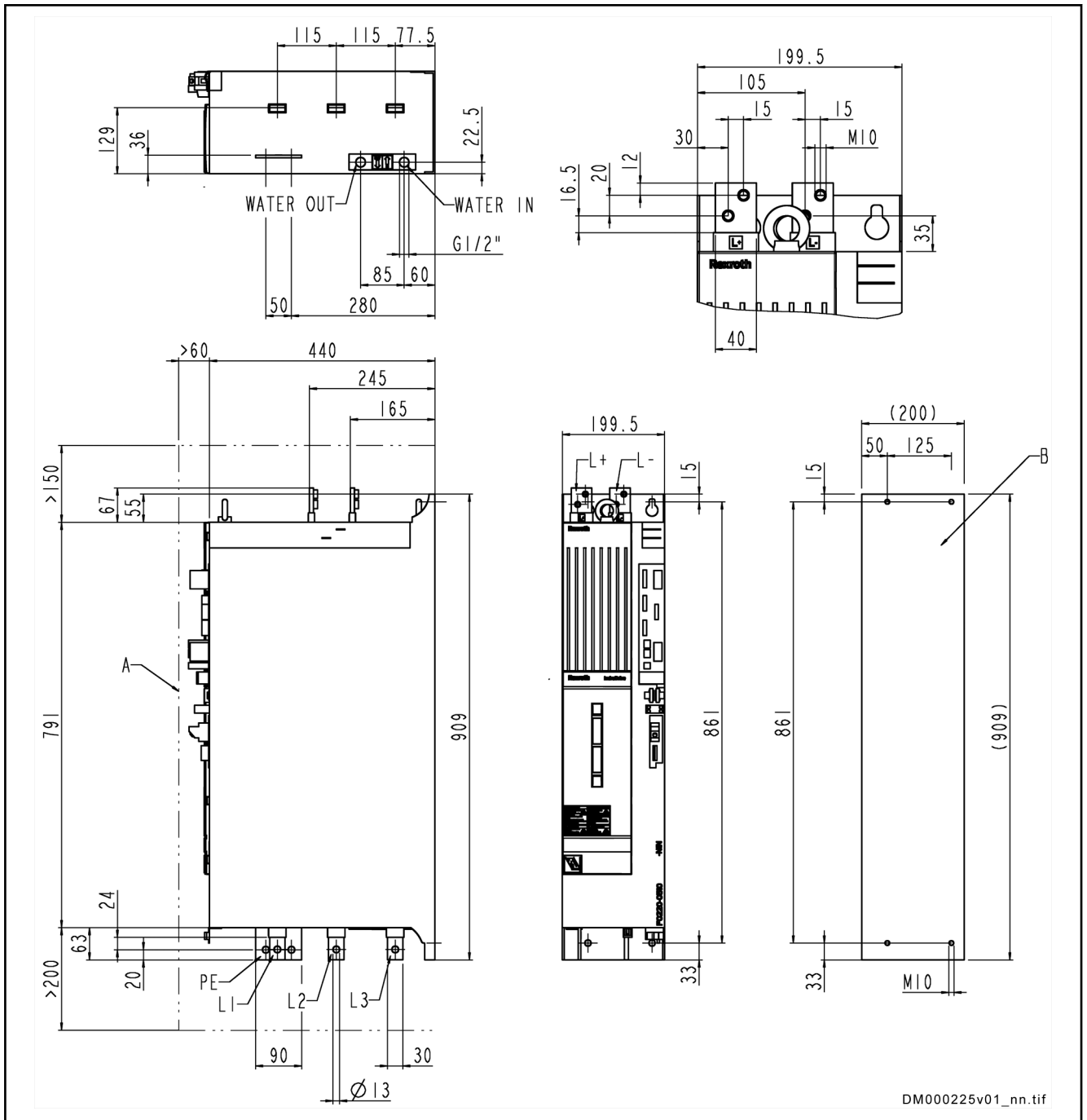

A Minimum mounting clearance
B Boring dimensions

Fig. 2-5: HMU05.1N-F0220-0510

DM000225v01_nn.tif

2.3.5 HMU05.1N-F0340-0820

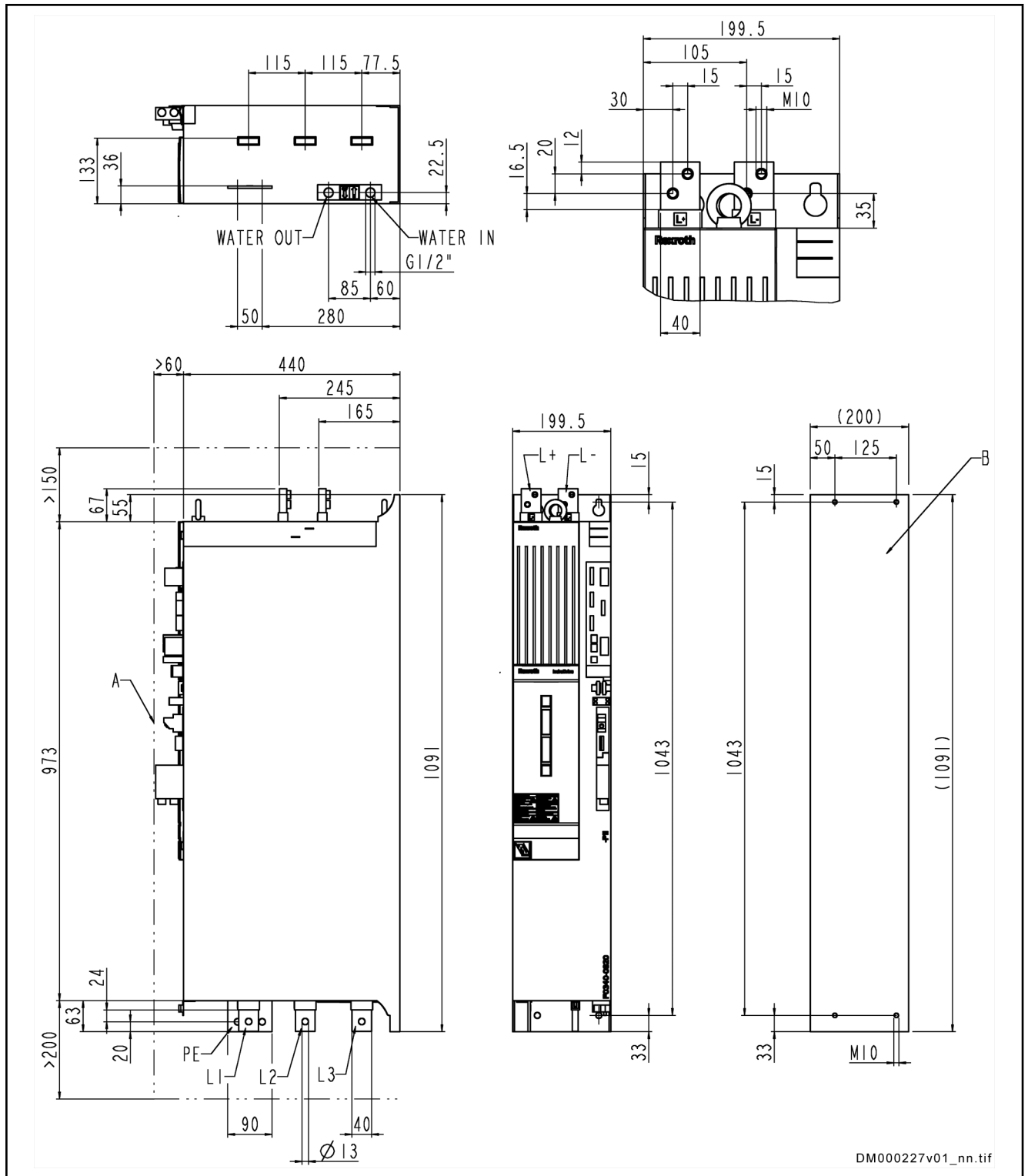

DM000227v01_nn.tif

A Minimum mounting clearance
B Boring dimensions

Fig. 2-7: HMU05.1N-F0340-0820

Ratings and dimensions

2.3.6 HMU05.1N-F0430-1040

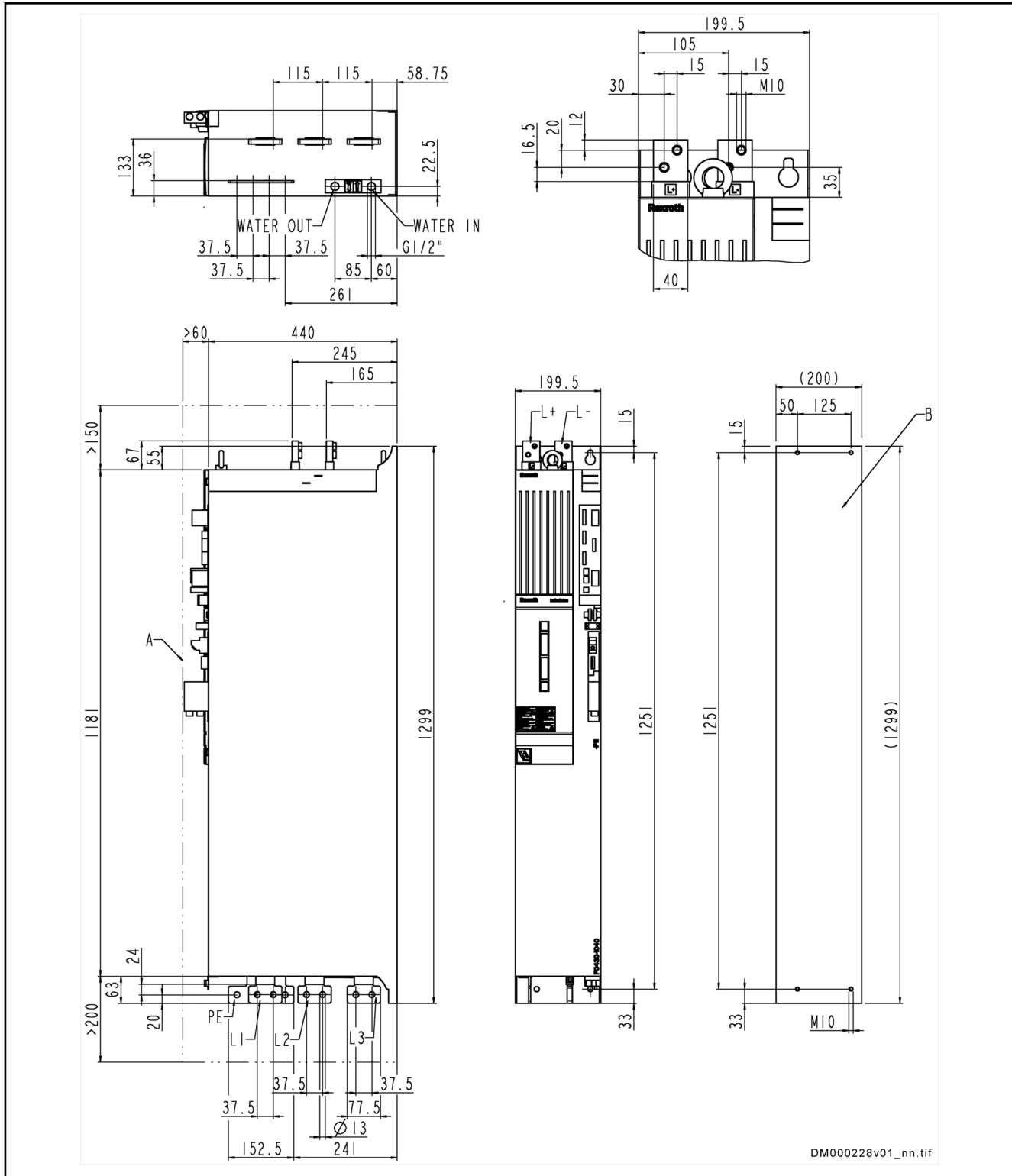

A Minimum mounting clearance
B Boring dimensions

Fig. 2-8: HMU05.1N-F0430-1040

2.3.7 HMU05.1N-F0540-1300

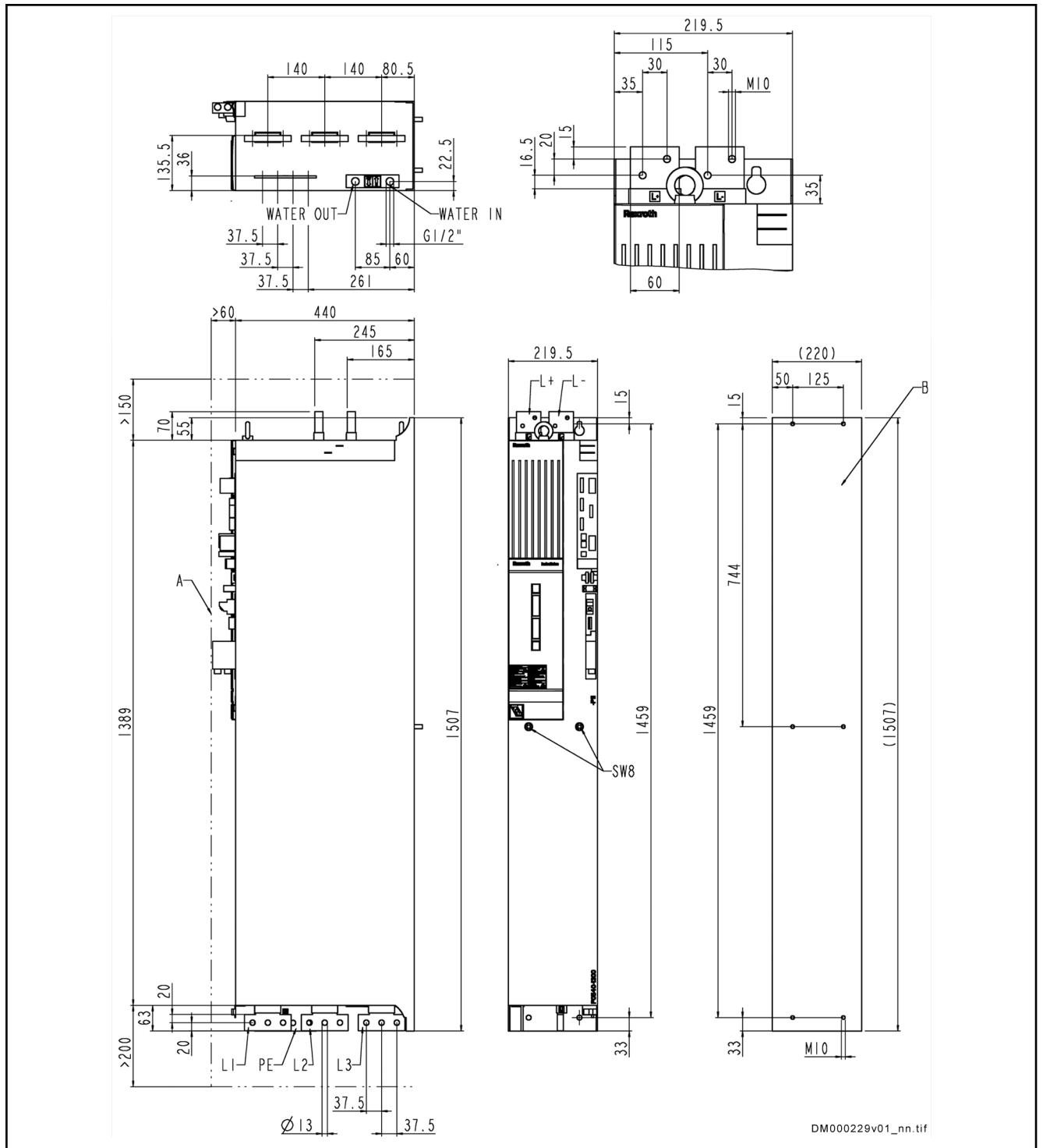

DM000229v01_nn.tif

A Minimum mounting clearance
B Boring dimensions
 Fig. 2-9: HMU05.1N-F0540-1300

Ratings and dimensions

2.4 HNA05 ratings

Description	Unit	HNA05.1N-WR02F5-...	
		A4	A5
Degree of protection		IP20	
Allowed mounting position		G1	
Ambient temperature range	°C	0 ... 55	
Mass	kg	6,70	
Insulation resistance	MΩ	50	
Y-capacitance		-	
Installation height	mm	390	
Installation width	mm	124.5	
Cooling type		Air cooling	
Distance top	mm	80	
Distance bottom	mm	80	
Distance side	mm	0	
Charging power dissipation	W	150	
Basic power dissipation in operation	W	50	
Rated power consumption control voltage input at U_{N3}	W	< 15	
Control voltage inrush current	A	< 3	
Inrush current duration	ms	< 2	
Control voltage U_{N3}	V	24	
Tolerance of control voltage U_{N3}	%	±20	
Input capacitance of control voltage U_{N3}	mF	0.05	
Control voltage input current	mA	500	
Rated mains input voltage U_{nenn}	V	AC 400	AC 690
Three-phase mains input voltage (TN-S, TN-C, TT mains)	V	AC 380 ... 500	AC 380 ... 690
Mains input voltage tolerance	%	+10 / -15	
Mains frequency	Hz	50 ... 60	
Maximum allowed mains frequency change	Hz/s	1	
Mains frequency tolerance	Hz	±2	
Rotary field condition		None	
Minimum inductance of mains supply	μH	40	
Charging mains input current	A	< 10	
Mains fuse	A	≤ 16	
Power mains input connection cross section	mm ²	2.5	
DC bus connection cross section	mm ²	2.5	

Ratings and dimensions

Description	Unit	HNA05.1N-WR02F5-...	
		A4	A5
DC bus connection cable length	m	< 2; twisted	
Upper DC bus voltage limit	V	900	1300
Output voltage	V	$U_{\text{nenn}} \times \sqrt{2} + 30$	
Nominal output current	A	10	
Max. chargeable energy	kWs	680	1265
Max. chargeable output voltage	V	808	1100
Max. charging time	s	240	
Maximum capacitance at 500 V	F	2.5	
Minimum capacitance at output	mF	1	
Short circuit current rating (SCCR)	kA rms	85	

Tab. 2-3: HNA05 ratings

Distances

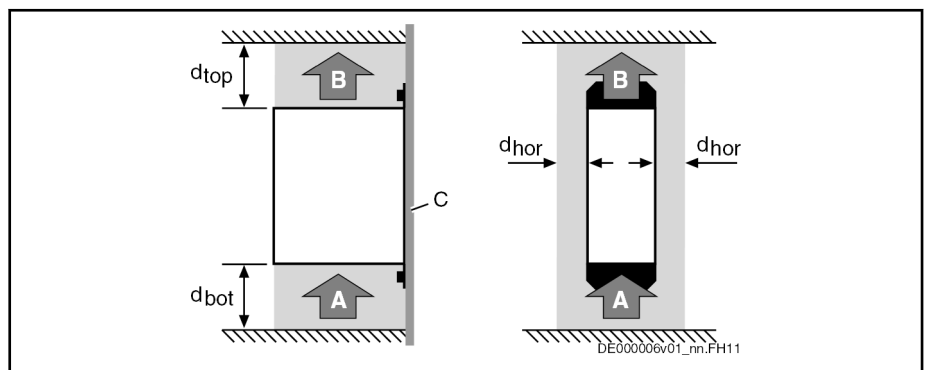

- A Air intake
- B Air outlet
- C Mounting surface in control cabinet
- d_{top} Distance top
- d_{bot} Distance bottom
- d_{hor} Distance horizontal

Fig. 2-10: Air intake and air outlet at device

Ratings and dimensions

HNA05, dimensional drawing

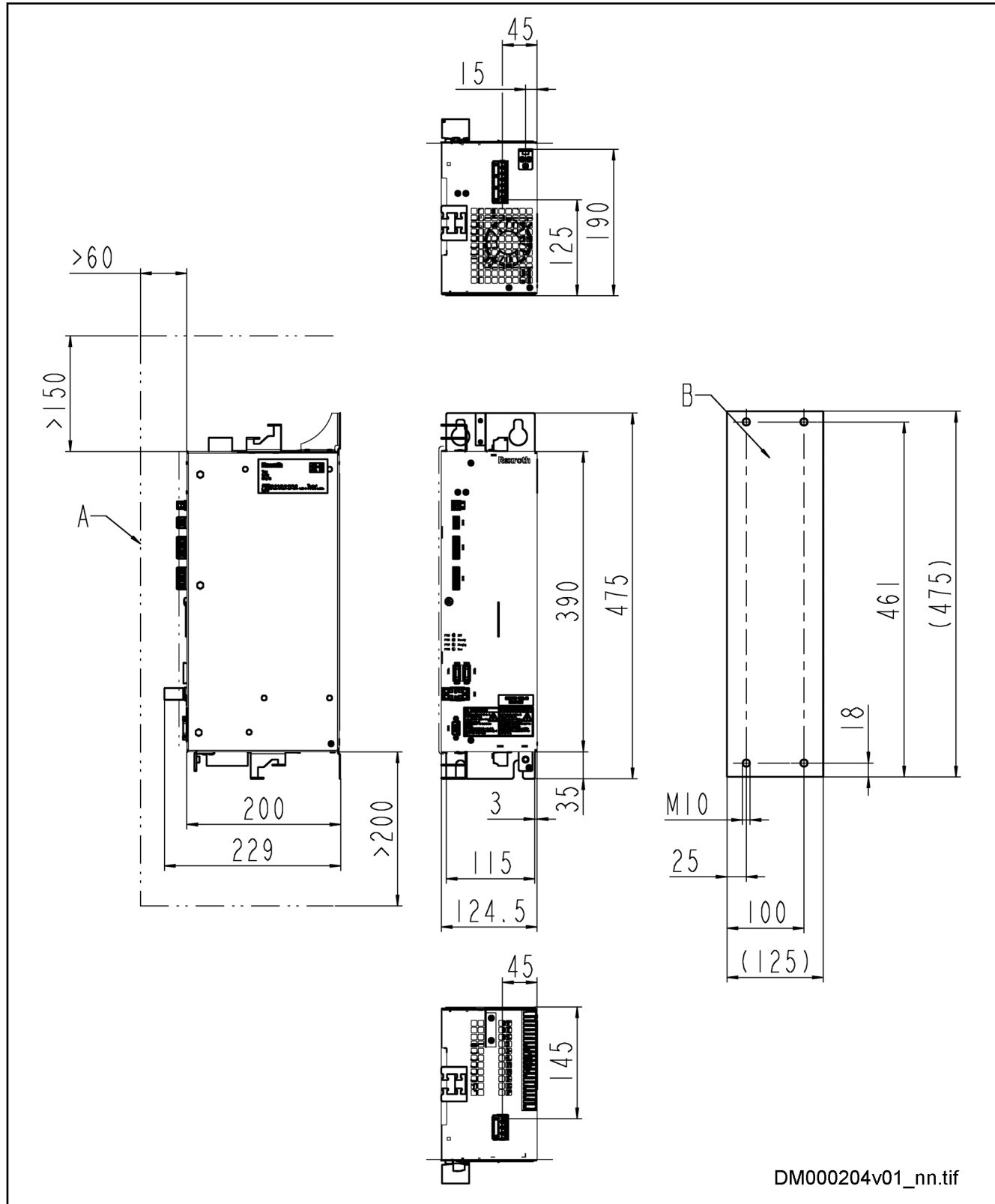

DM000204v01_nn.tif

M10

Fig. 2-11:

Tightening torque: 40 Nm

HNA05, dimensional drawing

2.5 HLT05 ratings

Description	Symbol	Unit	HLT05.1W- ... -0-N-D7-NNNN		
			45K	105K	245K
Continuous power	P_{BD}	kW	45	105	245
Short time power (60 s)	P_{BK}	kW	60	145	350
Peak power (2 s)	P_{BS}	kW	85	205	495
Minimum braking resistance	R_{min}	Ω	5.4	2.7	1.0
Balancing factor for P_{BD} (for parallel operation at common DC bus)	f		0.95		
Min. braking transistor switch-on threshold	$U_{HLT_On_min}$	V	820		
Max. braking transistor switch-on threshold	$U_{HLT_On_max}$	V	850		
Workload-based delay of braking transistor switch-on threshold	$U_{HLT_On_d}$	V	30		
Emergency comparator switch-on voltage	U_{Not}	V	943 \pm 2.5%		
Max. input voltage	U_{max}	V	980		
Continuous current for DC connection points	I_{nom}	A	100	200	500
Power dissipation (full load)	P_{Diss_max}	W	250	400	1000
Power dissipation (standby)	P_{Diss_min}	W	20		
Rated control voltage input	U_{N3}	V	24 \pm 20%		
Control voltage input current	I_{N3}	mA	470		630
Short circuit current rating	SCCR	kA rms	85		
Weight	m	kg	7.5		23

Tab. 2-4: HLT05, ratings

Ratings and dimensions

HLT05.1W-045K, -105K, dimensional drawing

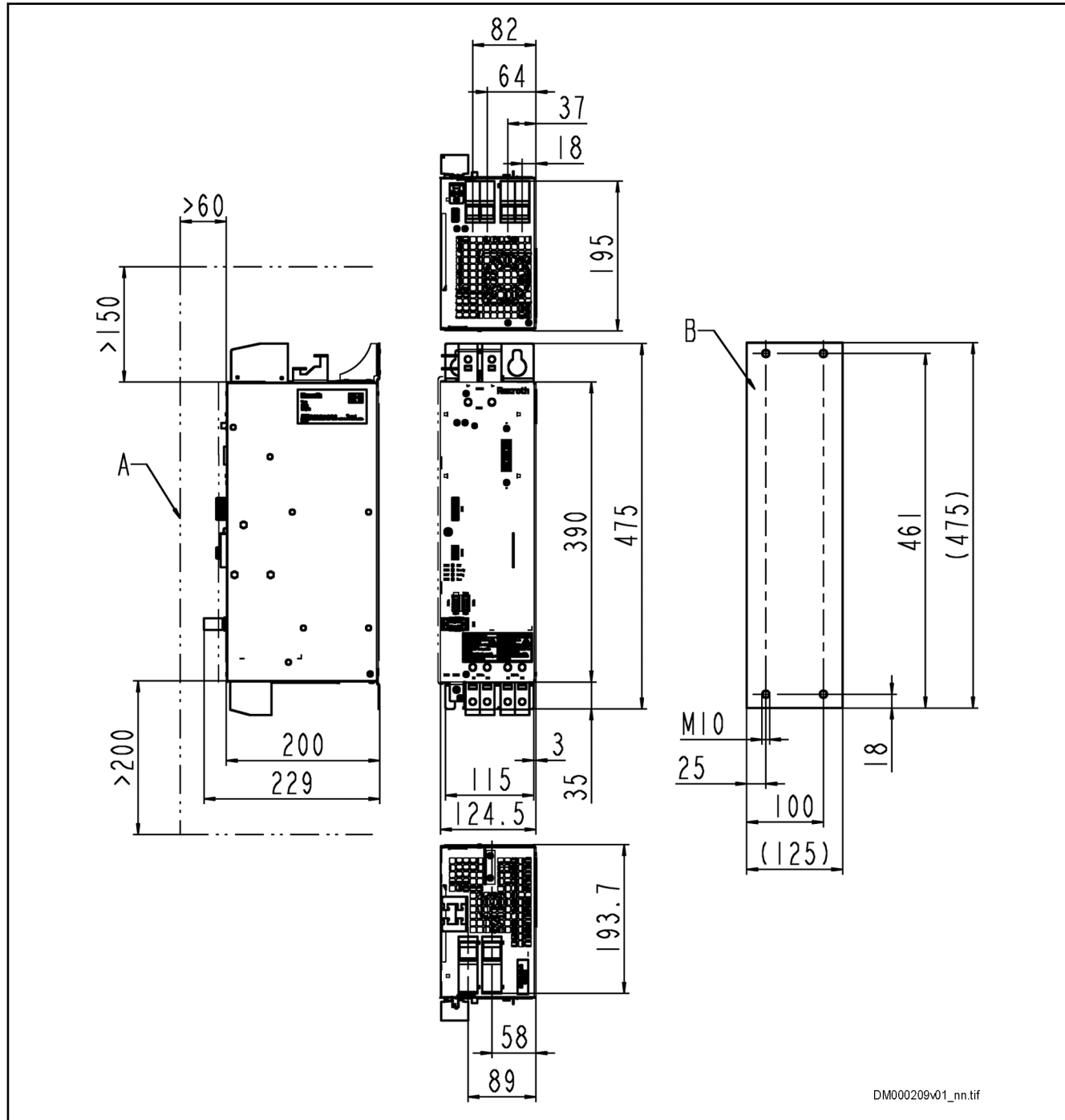

DM000209v01_nn.tif

A Minimum mounting clearance
B Boring dimensions
 Fig. 2-12: HLT05.1W-045K, -105K, dimensional drawing

HLT05.1W-245K, dimensional drawing

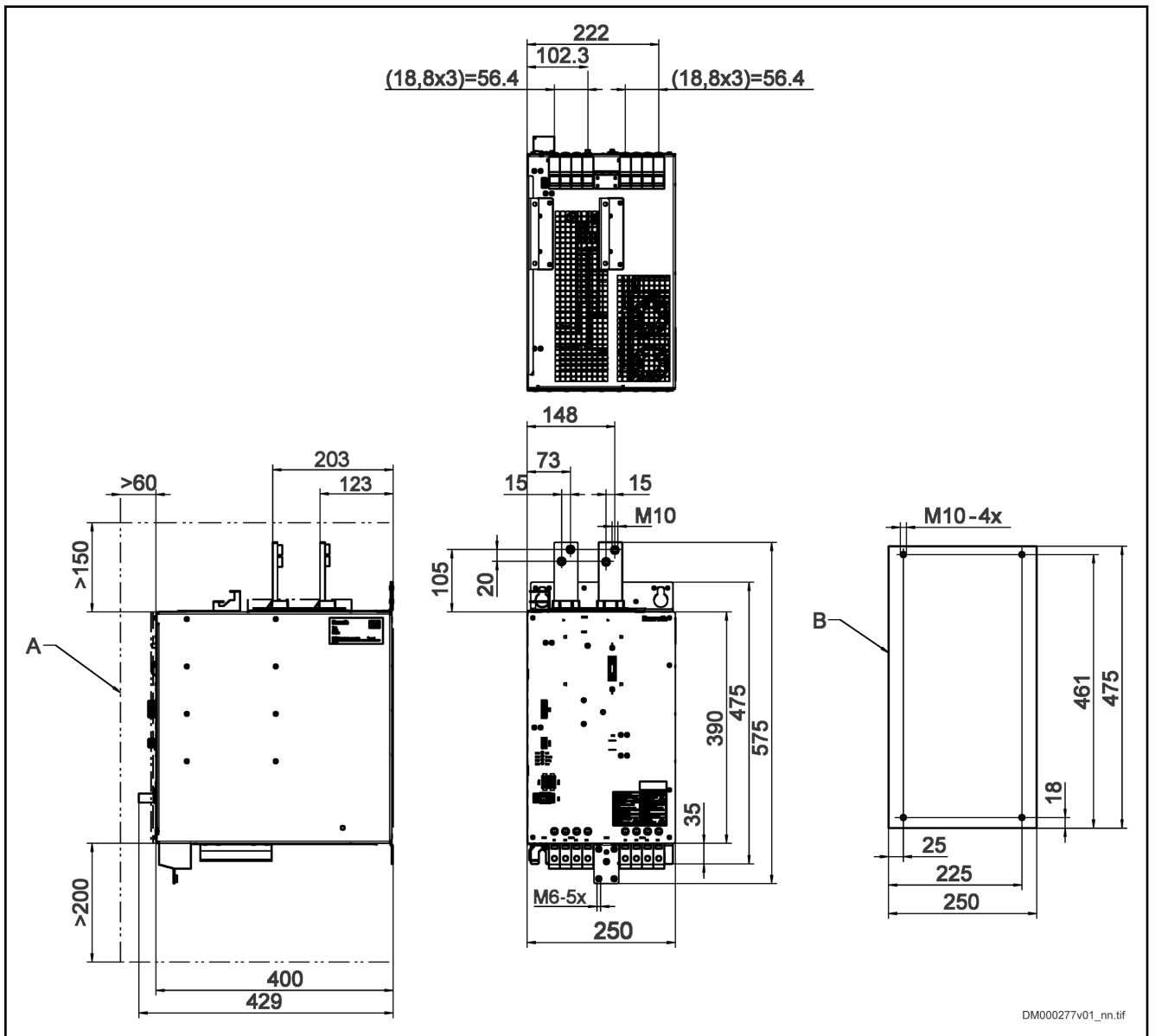

DM000277v01_nn.tif

A Minimum mounting clearance
B Boring dimensions

Fig. 2-13: HLT05.1W-245K, dimensional drawing

3 Instructions for use

3.1 Mounting HMU05 devices in control cabinet

HMU05 drive controllers were designed to be **mounted in control cabinets**.

- Notes on mounting**
- Observe the mandatory **minimum distances** of the component (see component dimensional drawing).
 - Use the appropriate **lifting tools** to lift the component at the **eyebolts** on the top of the component.
 - Observe the component **weight** (see component data). The mounting plate in the control cabinet has to withstand this weight.
 - **Tightening torque** of the **M10** mounting screws: **48 Nm**
 - Optional mounting kit: HAS08.1-008-NNN-MH (mat. no.: R911369743)
 - Optional mounting accessories:
 - Mounting plate for device width 200 mm: HAS10.1-002-005
 - Mounting plate for device width 220 mm: HAS10.1-002-006

3.2 Overcurrent protection

Protect the components against overcurrent:

- Branch circuit protection has to be provided externally
- Dimension the branch circuit protection according to the data "Branch circuit protection fuse" (see Ratings and dimensions)
- Install fuses for the control voltage supply

3.3 Short circuit protection

Integral solid state short circuit protection does not provide branch circuit protection.

UL: Branch circuit protection must be provided in accordance with the Manufacturer Instructions, National Electrical Code and any additional local codes.

CSA (for Canada): Branch circuit protection must be provided in accordance with "Canadian Electrical Code, Part I".

3.4 Overload protection

Overload protection operates at 100% of the full load current rating of the motor. The drive parameter shall be set at no more than the full load current rating of the motor. Motor overtemperature protection is provided.

3.5 Connection diagrams

3.5.1 Overall connection diagram (HMU05 as supply unit)

Overall connection diagram with load contactor



For your drive system, preferably use the connection with a load contactor pictured here (instead of the connection with a controllable main switch).

Instructions for use

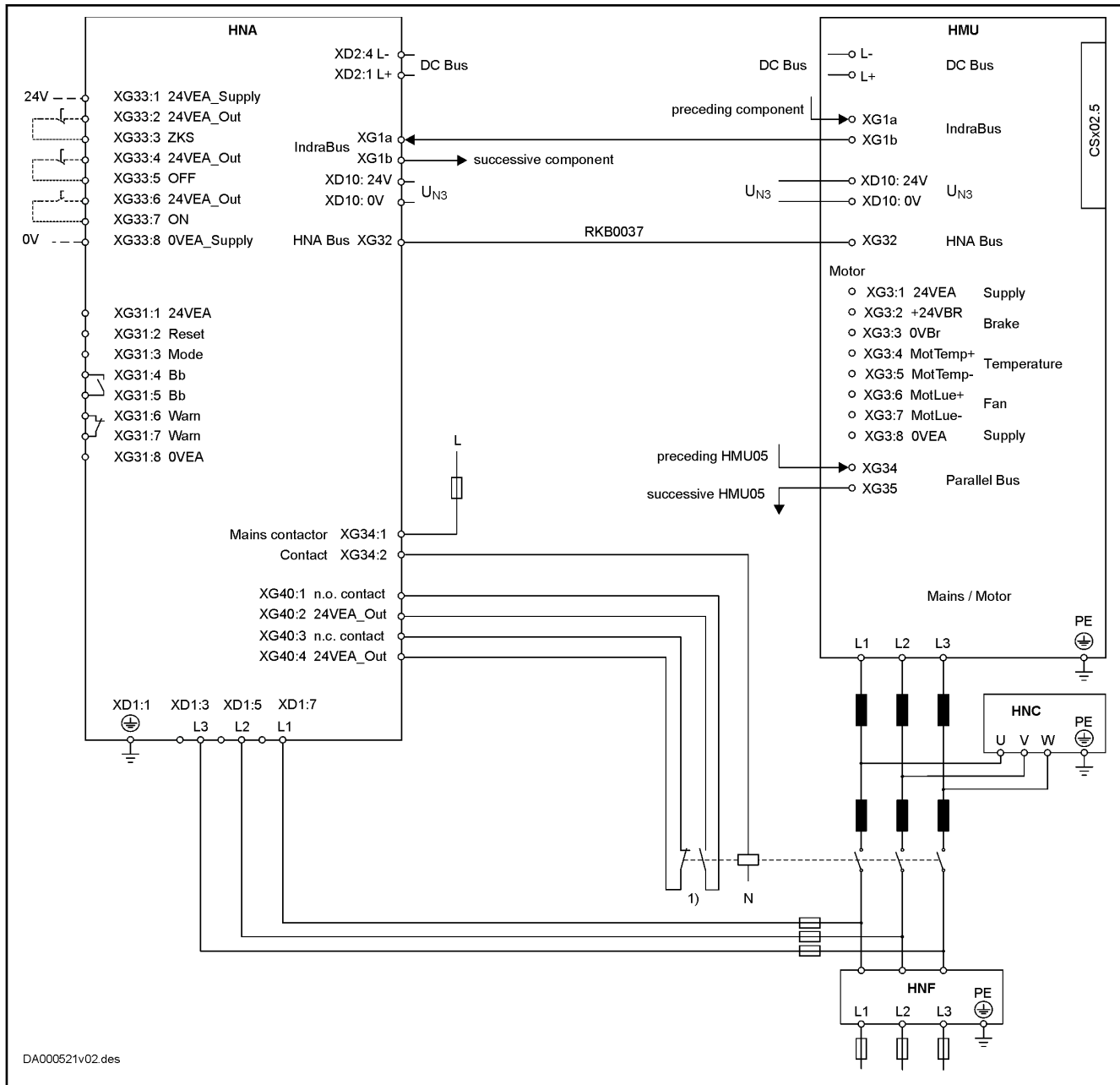

1) With multiple contactors connected in parallel, connect the N/O contacts and N/C contacts in series.
 Fig. 3-1: Connection diagram with load contactor (HMU05 as supply unit)

Overall connection diagram with a controllable main switch



For your drive system, preferably use the connection with a load contactor (instead of the connection with a controllable main switch).



Transient oscillation processes between HNC and mains inductance can occur when the main switch is turned on. Therefore, select an appropriate main switch.



Observe the local regulations regarding EMC and standards.

Instructions for use

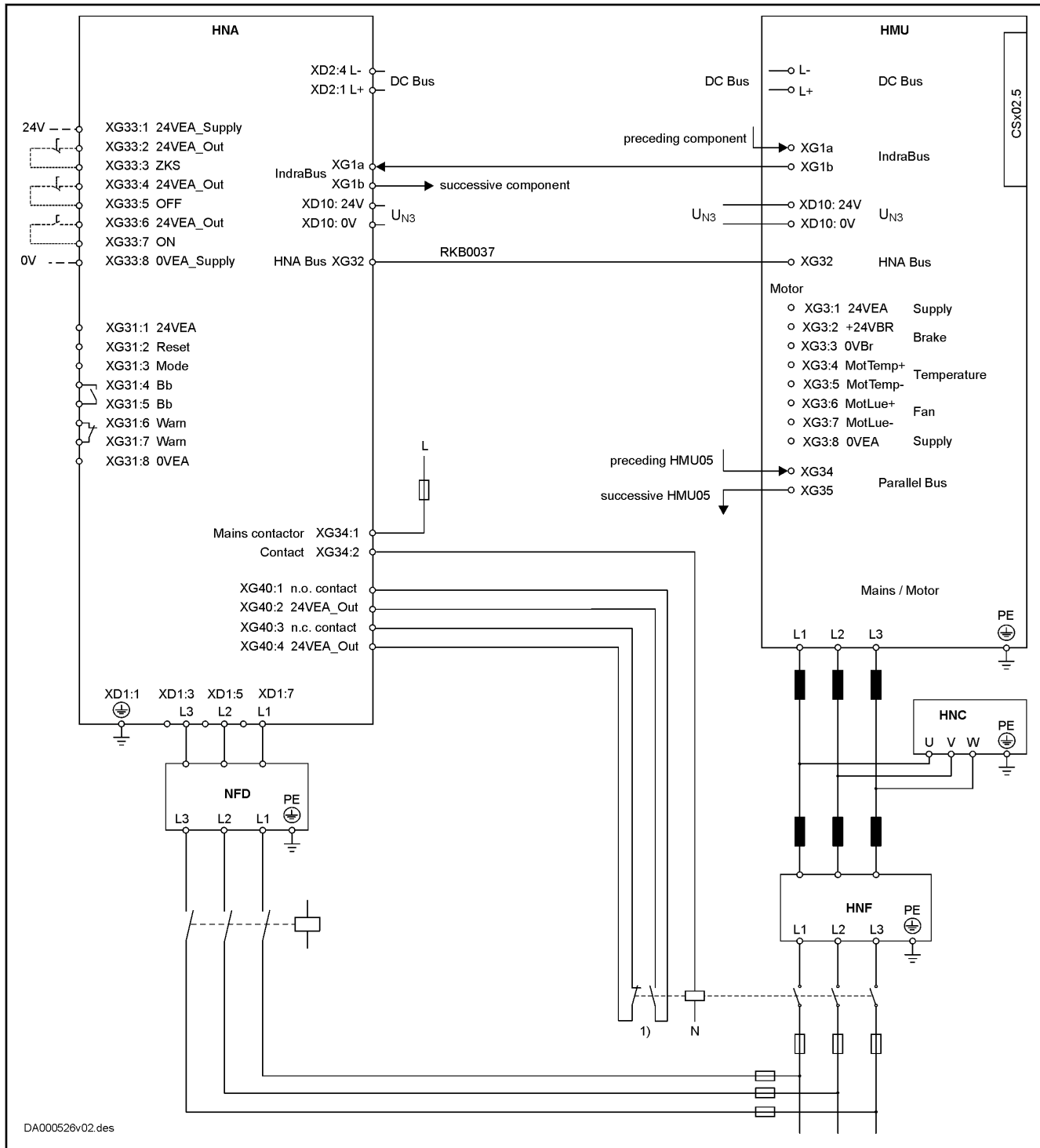

DA000526v02.des

1) With multiple main switches connected in parallel, connect the N/O contacts and N/C contacts in series.
 Fig. 3-2: Connection diagram with controllable main switch (HMU05 as supply unit)

3.5.2 Overall connection diagram (HMU05 as drive controller)

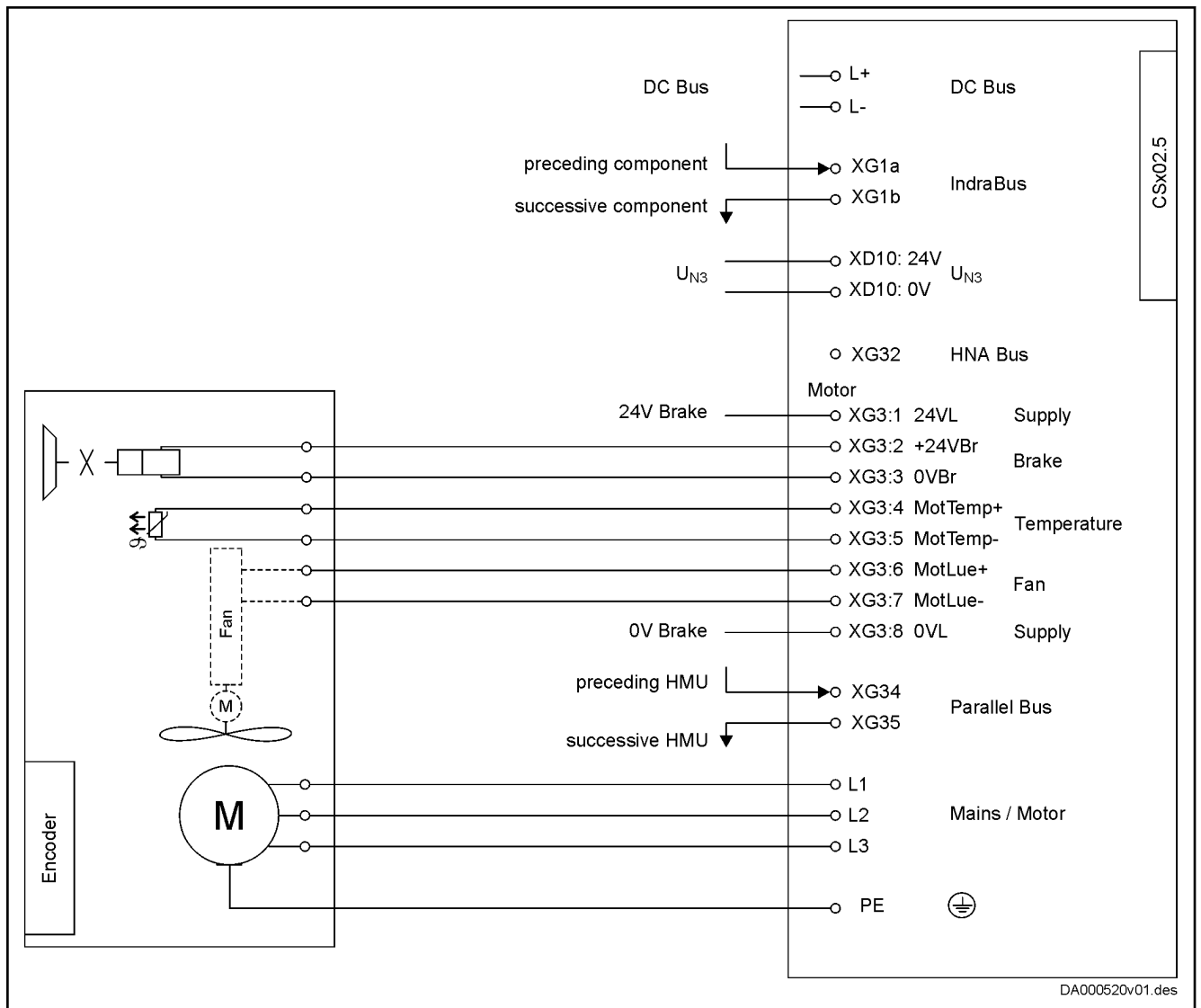

Fig. 3-3: Connection diagram (HMU05 as drive controller)

Instructions for use

3.5.3 HLT05 connection diagram (braking unit)

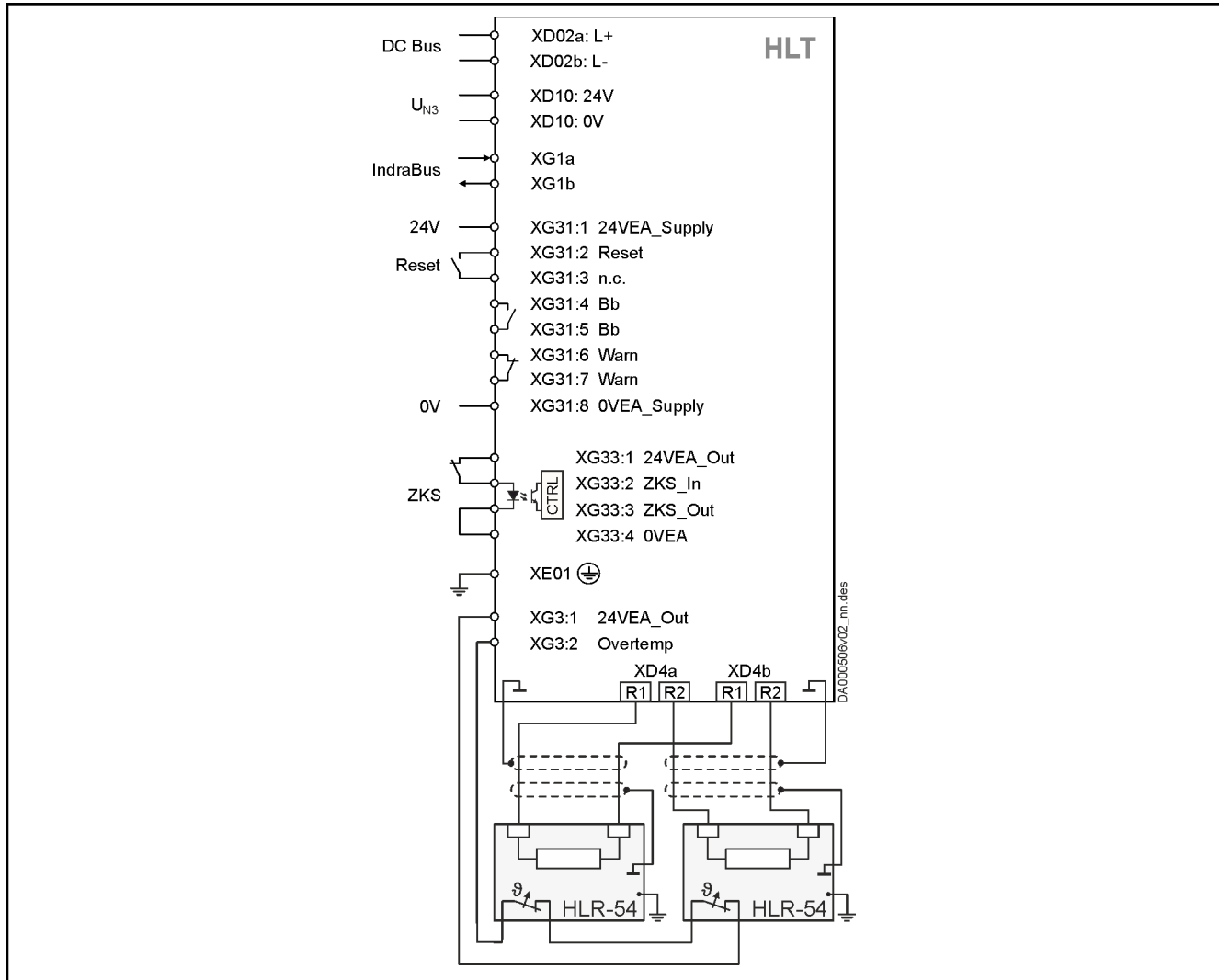

Fig. 3-4: HLT05.1W-045K, -105K connection diagram

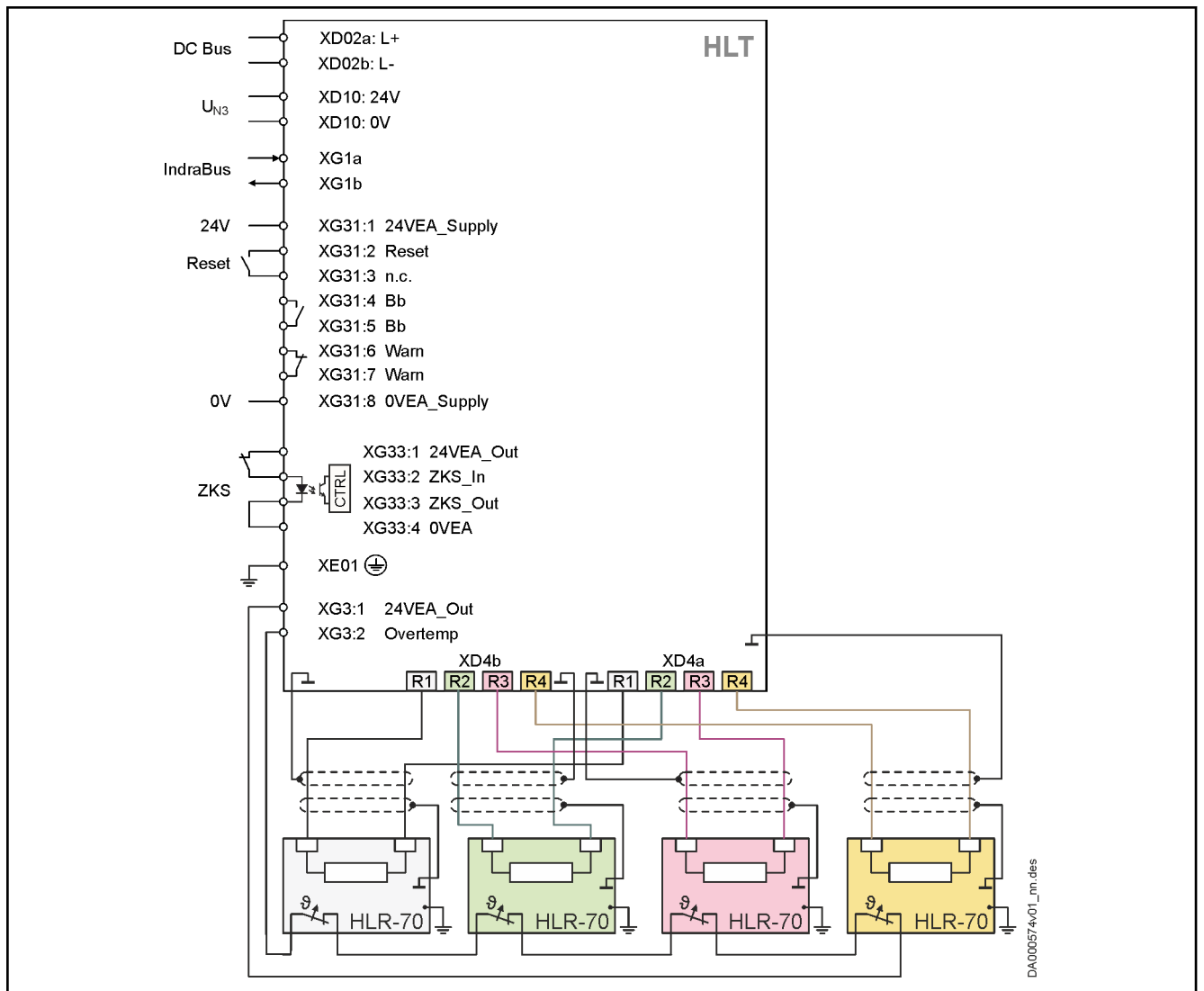

Fig. 3-5: HLT05.1W-245K connection diagram

Instructions for use

3.6 Connection points







3.6.1 HMU05 connection points

WARNING















Lethal electric shock from live parts with more than 50 V!

Mount a touch guard for the exposed connection points "L+/L-" and "L1, L2, L3" following connection work in the control cabinet.

Always wait **30 minutes** after switching off power to allow live capacitors to discharge before accessing an electrical component. Measure the electrical voltage of live parts before beginning to work to make sure that the equipment is safe to touch.

Symbols used to describe the connection points							
Spring terminal	D-Sub	Thread	Hole	Quickie®	Max. connection cross section	Stripped length	Max. tightening torque
→					\varnothing		

Tab. 3-1: Symbols

Connection point	    	 mm \varnothing mm ² (AWG)	 mm	 Nm
		13	-	M10: 25 M12: 48
L1, L2, L3		13	-	M10: 25 M12: 48
L+, L-		2 × M10	-	48
XD10	→	10 (8)	10	-
XG1		-	-	-
XG3 ¹⁾	→	1.5 (16)	10	-
XG32 ¹⁾		-	-	-

1) HPC01.1-MN0x option
Tab. 3-2: Connection points

HMU05 connection points

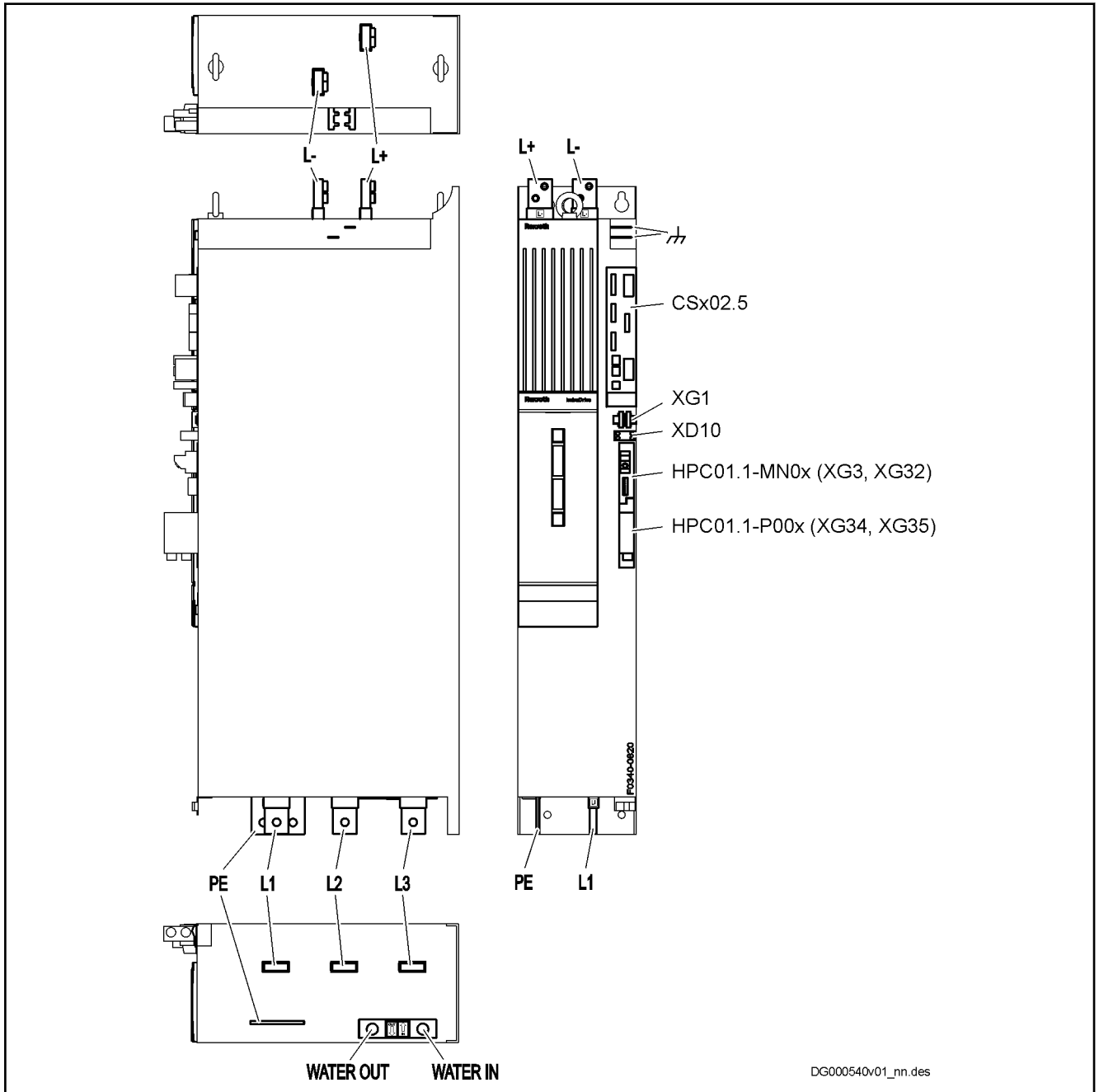









DG000540v01_nn.des

- | | |
|---------------------|-------------------------------|
| CSx02.5 | Control section |
| HPC01 | Optional card |
| L1, L2, L3 | Mains/motor connection |
| L+, L- | DC Bus |
| PE | Equipment grounding conductor |
| XG1 | IndraBus |
| XD10 | Control voltage |
| WATER IN/OUT | Cooling liquid |



















Fig. 3-6: HMU05 connection points

Instructions for use

3.6.2 HNA05 connection points

Symbols used to describe the connection points							
Screw connection	Spring terminal	D-Sub	Thread	Quickie®	Max. connection cross section	Stripped length	Max. tightening torque
							

Tab. 3-3: Symbols

Connection point	    	\varnothing mm ² (AWG)	 mm	 Nm
		M6 × 25	-	10.5
XD1		10 (8)	10	0.8
XD2		10 (8)	10	0.8
XD10		10 (8)	10	-
XG1		-	-	-
XG31		1.5 (16)	10	-
XG32		-	-	-
XG33		1.5 (16)	10	-
XG34		1.5 (12)	10	0.6
XG40		1.5 (16)	10	-

Tab. 3-4: Connection points

3.6.3 HLT05 connection points

Symbols used to describe the connection points						
Screw connection	Spring terminal	Thread	Quickie®	Max. connection cross section	Stripped length	Max. tightening torque

Tab. 3-5: Symbols

Connection point		 mm ² (AWG)	 mm	 Nm
(XE01)		M6 × 25	-	10.5
XD02a, XD02b		95 (4/0)	27	15
XD4a, XD4b		50 (1/0)	24	6
XD10		10 (8)	10	-
XG1		-	-	-
XG3		1.5 (16)	10	-
XG31		1.5 (16)	10	-
XG33		1.5 (16)	10	-

Tab. 3-6: Connection points

4 Service and support

Our worldwide service network provides an optimized and efficient support. Our experts offer you advice and assistance should you have any queries. You can contact us **24/7**.

Service Germany Our technology-oriented Competence Center in Lohr, Germany, is responsible for all your service-related queries for electric drive and controls.

Contact the **Service Hotline** and **Service Helpdesk** under:

Phone: **+49 9352 40 5060**
Fax: **+49 9352 18 4941**
E-mail: service.svc@boschrexroth.de
Internet: <http://www.boschrexroth.com/>

Additional information on service, repair (e.g. delivery addresses) and training can be found on our internet sites.

Service worldwide Outside Germany, please contact your local service office first. For hotline numbers, refer to the sales office addresses on the internet.

Preparing information To be able to help you more quickly and efficiently, please have the following information ready:

- Detailed description of malfunction and circumstances
- Type plate specifications of the affected products, in particular type codes and serial numbers
- Your contact data (phone and fax number as well as your e-mail address)

Index

A

Ambient conditions.....	7
Appropriate use.....	6

C

Connection	
Connection diagram (HMU05 as drive controller).....	29
Connection diagram (HMU05 as supply unit).....	25
Connection diagram	
HLT05 (braking unit).....	30
Connection points	
HLT05.....	35
HMU05.....	32
HNA05.....	34

D

Data	
HMU05, dimensional drawing.....	11
HMU05, dimensions.....	11
Dimensional drawing	
HMU05.....	11
Dimensions.....	7

H

Helpdesk.....	37
HLT05	
Technical data.....	21
HMU05	
Dimensional drawing.....	11
Dimensions.....	11
Mounting in control cabinet.....	25
Technical data.....	7
HNA05	
Technical data.....	18
Hotline.....	37

I

Instructions for use.....	25
---------------------------	----

M

Mounting	
HMU05 in control cabinet.....	25

O

Operating conditions.....	7
Overcurrent protection.....	25
Overload protection.....	25

P

Power consumption.....	7
------------------------	---

R

Ratings.....	7
--------------	---

S

Safety instructions.....	3
Service hotline.....	37
Short circuit protection.....	25
Support.....	37

T

Technical data.....	7
---------------------	---

U

UL ratings.....	7
Use	
Appropriate.....	6
Instructions.....	25

V

Voltage load capacity.....	7
----------------------------	---

Notes

Notes

Bosch Rexroth AG

Electric Drives and Controls

P.O. Box 13 57

97803 Lohr, Germany

Bgm.-Dr.-Nebel-Str. 2

97816 Lohr, Germany

Phone +49 9352 18 0

Fax +49 9352 18 8400

www.boschrexroth.com/electrics



R911345961