

# Valve amplifier for proportional valves without electrical position feedback; maximum current limitation 1.5 A

## Type VT-MSPA2...1A5



H8134

- ▶ Component series 2X
- ▶ Easy valve selection of the Rexroth valves for industrial hydraulics
- ▶ Characteristic curves of the valves stored in the device
- ▶ Valve optimization via push-buttons
- ▶ All valve parameters adjustable
- ▶ For valve with one or two solenoids and 24 V nominal voltage

### Features

- ▶ Command value input 0 ...  $\pm 10$  V
- ▶ Maximum ambient temperature range 70 °C
- ▶ Reverse polarity protection of the operating voltage
- ▶ Ramp generator up and down is separately adjustable
- ▶ Zero point setting
- ▶ Command value adjustment
- ▶ Characteristic curve generator
- ▶ Clocked power output stage
- ▶ Output short-circuit-proof
- ▶ LED status displays
- ▶ Measuring sockets for actual current value, internal current command/setting

### Contents

Features	1
Ordering code	2
Function	3
Block diagram	4
Technical data	5, 6
Dimensions	7
Status description LEDs	8
Accessories	8
Project planning and maintenance instructions	9
Further information	9



## Function

### General

The valve amplifiers are intended for assembly on top hat rails. The electrical connection is established via 3 tension spring plug-in connectors. The supply voltage is 24 VDC.

### Power supply unit (1)

The internal power supply unit has a making current limiter to prevent current peaks. Additionally, inverse-polarity protection is integrated.

### Command value, command value summing device (3)

The "internal command value" comprises:

- ▶ "External command value", connected at the input of the differential amplifier (2)
- ▶ Zero point offset (4), "Z/B" adjustable in the standard setup
- ▶ Via solenoid B, a command value of 0 ... +10 V results in a flow in the valve from P to A and from B to T.
- ▶ Via solenoid A, a command value of 0 ... -10 V results in a flow in the valve from P to B and from A to T. In the expert setup, it is possible to invert the command value (5) (see operating instructions 30232-02-B).
- ▶ In normal operation, the "internal command value" can be measured at the "v" measuring socket.

### Ramps

A ramp limits the incline of the command value. You can choose between a single ramp (6) (one time for all ramps, default value) and a 4Q/2Q ramp (7) (different times for the possible ramps). The 4Q/2Q ramp times are set in the expert setup. The characteristic curve generator (9) does not influence the ramp time.

### Command value attenuator "G" (8)

By means of the command value attenuator, the command value can be reduced.

### Characteristic curve generator (9)

In the characteristic curve generator, the pre-set valve characteristic curve can be adjusted to the actual hydraulic and control-technical conditions.

The following can be adjusted in the expert setup:

- ▶ Pilot current "B"
- ▶ Step "S"
- ▶ Maximum current "G" (separately possible for solenoid A and B)

### Current controller (10)

The solenoid current is recorded, compared to the command value in the current controller and the difference is compensated.

### Clock generator (11)

The clock generator creates the clock frequency "f" of the output stage. With Rexroth valves, the clock frequency sometimes changes dependent on the command value and/or the operating voltage.

### Power output stage (12)

The power output stage creates the clocked solenoid current for the proportional valve. The solenoid current is limited to the maximum admissible current per output, depending on the set valve. The output stages are short-circuit-proof. With an internal interference signal or in case enable is missing, the output stage will be switched off.

### Digital input (13)

The input DI can be set to four different functions:

- ▶ 1. Enable (factory setting)
- ▶ 2. Command value inversion (permanent enable)
- ▶ 3. Ramp on/off (permanent enable)
- ▶ 4. Single or quadrant ramp (permanent enable)

### Digital output (15)

Device reports ready for operation if there is no cable break, no internal error and  $U_B \geq U_{B \min}$ .

See also "block diagram," on page 4.

Block diagram

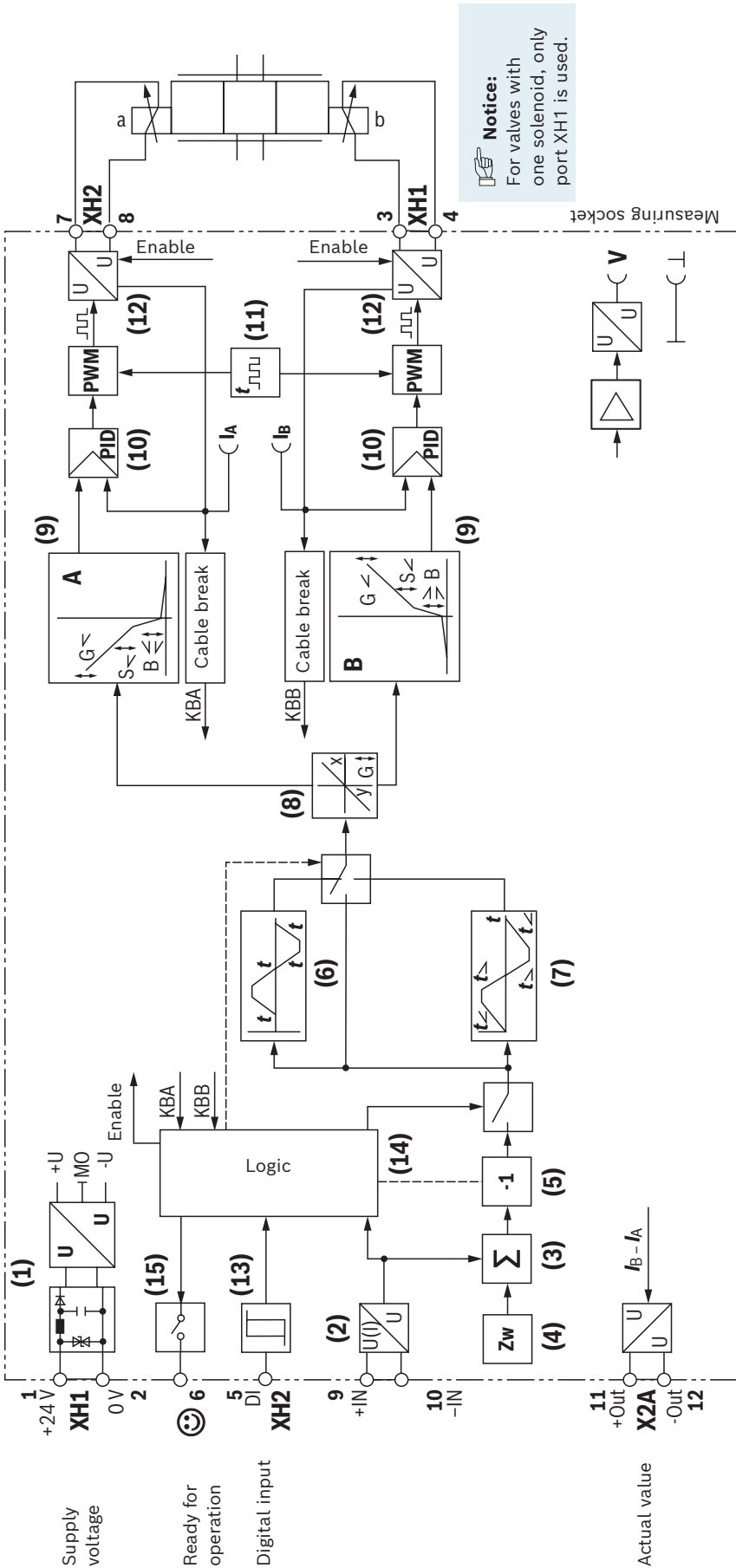

**Notice:**  
For valves with one solenoid, only port XH1 is used.

- 1 Power supply unit
- 2 Differential amplifier
- 3 Command value summing device
- 4 Zero point setting
- 5 Inverter
- 6 Single ramp
- 7 4-quadrant ramp
- 8 Command value attenuator
- 9 Characteristic curve generator
- 10 Current controller
- 11 Clock generator
- 12 Output stage
- 13 Enable / inverting / ramp off / 4Q ramp
- 14 Switching logics / fault recognition
- 15 Digital output

See also "Function" on page 3.

## Technical data

General		
Design		Module
Type of connection		3 tension spring plug-in connectors, detachable
Weight	kg	0.14
Installation position		Vertical. For the breathing of the assembly, the ventilation slots of the top and bottom side must be at least 2 cm away from covers, walls, etc. With an ambient temperature of more than 50 °C, the clearance to the next assembly must be 1 cm.
Ambient temperature range	°C	0 ... +70
Storage temperature range (with UV protection)	°C	+5 ... +40
Transport temperature range	°C	-40 ... +70
Relative humidity range (no condensation)	%	10 ... 95
Protection class according to EN 60529		IP20
Sine test according to EN 60068-2-6		10 ... 500 Hz / maximum 2 g / 10 cycles / 3 axes
Noise test according to EN 60068-2-64		20 ... 500 Hz / 2.2 g <sub>RMS</sub> / 6.6 g peak / 0.5 h / 3 axes
Transport shock according to EN 60068-2-27		15 g / 11 ms / 3 axes
Start-up time	s	<1
Maximum temperature change	°C/min	5
Maximum altitude for use	m	2000
UV resistance		Conditional; color changes possible with prolonged irradiation
Free fall (in original packaging)	m	1
Top hat rail assembly		TH35-7.5 or TH35-15 according to EN 60715
Housing material		Glass-fiber reinforced polyamide plastic
Resistance against aggressive media		Contact with conductive dusts is not admissible. Avoid contact with hydraulic fluids.
Conformity	<ul style="list-style-type: none"> <li>▶ CE according to EMC Directive 2014/30/EU, tested according to</li> <li>▶ RoHS Directive</li> </ul>	EN 61000-6-2 and EN 61000-6-3 2011/65/EU <sup>1)</sup>
Electro-magnetic compatibility (EMC)	<ul style="list-style-type: none"> <li>▶ EN 61000-6-2</li> <li>– EN 61000-4-2 ESD</li> <li>– EN 61000-4-3 HF radiated</li> <li>– EN 61000-4-4 Burst</li> <li>– EN 61000-4-5 Surge</li> <li>– EN 61000-4-6 HF conducted</li> <li>– EN 61000-4-8 Magnetic field 50/60 Hz</li> <li>▶ EN 61000-6-3 / EN 61000-6-4</li> <li>– EN 55016-2-1 Interference voltage</li> <li>– EN 55016-2-3 Radio interference field strength</li> </ul>	4 CD / 8 AD with BWK B 10 (80 ... 6000 MHz) with BWK A 2 (5 kHz and 100 kHz) with BWK B 0.5 (2 Ω/12 Ω) to operating voltage, 1 kV (42 Ω) to signal with BWK B 10 (150 kHz ... 80 MHz) with BWK A 100 with BWK A 0.15 ... 30 (Class A, EN 55022) 30 ... 6000 (Class B, EN 55022)

<sup>1)</sup> The product fulfills the substance requirements of the RoHS Directive 2011/65/EU.

## Technical data

Electrical				
Supply voltage	▶ Nominal value	V	24	
	▶ Minimum <sup>2)</sup>	V	18	
	▶ Maximum	V	36	
	▶ Maximum residual ripple (40 ... 400 Hz)	V <sub>pp</sub>	2.5 (Observe the admissible limits)	
	▶ Maximum power consumption	W	< 48	
	▶ Maximum current consumption	A	< 2	
	▶ Fuse protection, external	A	3.15 (time-lag)	
Maximum switch-on current		A	< 4	
Analog inputs (command value) X2A	▶ 1 Solenoid (0 ... 100%)			
	– Version "F5"	mA	4 ... 20	
	– Version "A5"	V	0 ... +10	
	▶ 2 Solenoids (0 ... ±100%)			
	– Version "F5"	mA	4 ... 20	
	– Version "A5"	V	0 ... ±10	
	▶ Voltage inputs (differential inputs)			
– Input resistance	kΩ	200		
▶ Current inputs	Ω	100 (load resistance)		
Analog outputs (actual value) <sup>3)</sup> X2A	▶ Voltage outputs			
	– Output range	$I_A$ (V ≙ A)	V	0 ... -2.5
		$I_B$ (V ≙ A)	V	0 ... 2.5
	– Minimum load impedance	kΩ	1	
Digital inputs XH2	▶ ON (active) <sup>4)</sup>	V	11 ... 36	
	▶ OFF (inactive)	V	-3 ... 5	
Solenoid outputs	▶ Maximum solenoid current	A	2.7	
	▶ Clock frequency setting range <sup>5)</sup>	Hz	95 ... 505	
	▶ Other properties		Short-circuit-proof, clocked	
	▶ Cable length (1.5 mm <sup>2</sup> )	m	50	
Adjustment options	▶ Zero point calibration	%	±10	
	▶ Command value attenuator <sup>6)</sup>	%	70 ... 110	
	▶ Ramp time up/down	s	0.01 ... 30	
	▶ Step level	%	0 ... 50	
Measuring sockets	▶ Command value/setting	"v"	V	0 ... ±10
	▶ Actual current value	$I_A$ (V ≙ A)	V	0 ... ±2.5
		$I_B$ (V ≙ A)	V	0 ... ±2.5
	▶ Reference potential	"⊥"		

2) 21 V for valves with a maximum solenoid current of 0.8 A

3) Maximum value depending on the selected valve

4)  $R_E > 50 \text{ k}$

5) Depending on the selected valve

6) At command value 100%

## Dimensions

(Dimensions in mm)

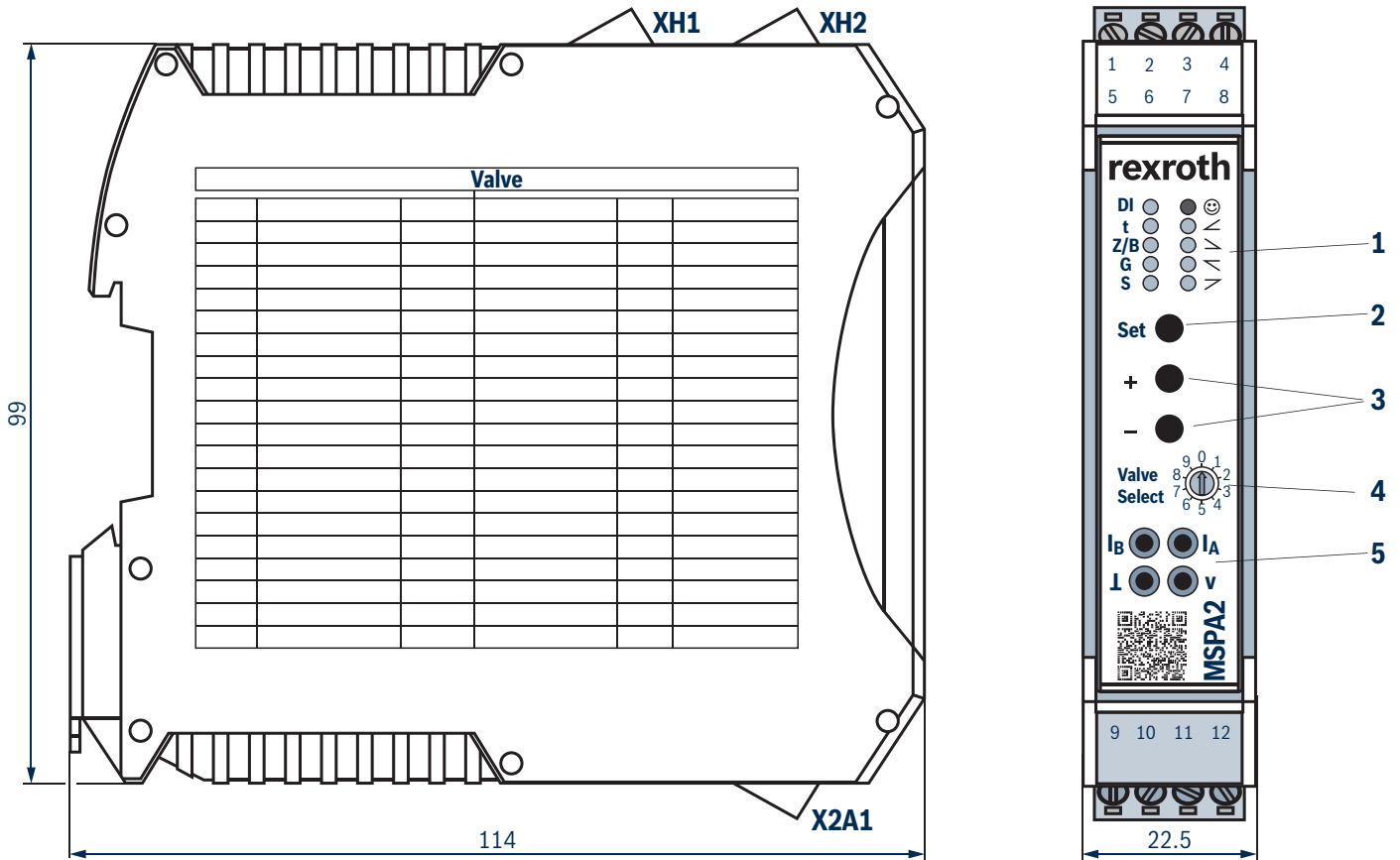

### 1 Status LEDs

Display the current operating state, menu levels and error conditions

### 2 SET key

Editing the selected parameters, selection of work operation, selection of the "expert mode"

### 3 + / - keys

Selection of the parameters and adjustment of the parameter values

### 4 Rotary switch

Valve type selection

### 5 Measuring sockets for connecting a measuring instrument

#### Assignment: Switch position/valve type

Switch position	Valve type
0	No valve
1	4WRA 6 WA15...2X...K10 4WRA 6 XA00...K10
2	4WRA 6 W30...2X...K10 4WRA 6 E00 ...2X ...K10
3	4WRZ ...7X...K10
9	Universal (1.5 A)

#### Terminal assignment

Assignment		Connector	Terminal
Operating voltage	+U <sub>B</sub>	XH1	1
	0 V	XH1	2
+ Solenoid B		XH1	3
- Solenoid B		XH1	4
Digital input		XH2	5
Ready		XH2	6
+ Solenoid A		XH2	7
- Solenoid A		XH2	8
+ Command value		X2A	9
- Command value		X2A	10
+ Actual value		X2A	11
- Actual value		X2A	12

## Status description LEDs

Indicator light	Operating state	Display mode	Meaning
"Digital input" LED (yellow)	Normal operation	Permanent light on/off	Digital input status
	Setup	Flashing	Standard setup active
	Setup	Off	Expert setup active
	Setup	On/flashing/flickering	Expert setup: Digital input setting
"Ready" LED (red/green)	Normal operation	Permanent light, green	Module ready for operation
	Normal operation	Permanent light, red	Error
	Normal operation and setup	Flashing light, red-green	Valve setting changed
	Normal operation and setup	Flashing light, red	Inadmissible valve number
	Normal operation	Off	Module not ready for operation
	Setup	Flashing light, green	Expert setup active

Description of the LED display <sup>1)</sup>	
DI	Enable <sup>2)</sup>
t	Ramp
Z/B	Zero point / pilot current
G	Command value attenuator
S	Step level command value
☺	Ready for operation
∠	1st quadrant (positive command value rising)
∩	2nd quadrant (positive command value falling)
∟	3rd quadrant (negative command value rising)
∟	4. Quadrant (negative command value falling)

<sup>1)</sup> A detailed description is contained in the operating instructions 30232-02-B

<sup>2)</sup> Function of the digital input can be adjusted in the setup

## Accessories (separate order)

	Material no.
Shield set for the installation with shielded lines	<b>R961011117</b>

## Project planning information

- ▶ In especially EMC-sensitive environments, additional measures must be taken (depending on the application, e.g. shielding, filtration)
- ▶ Wiring
  - Maximum possible spatial separation between signal and load lines.
  - Do not lead signal lines through magnetic fields.
  - If possible, install signal lines without intermediate terminals.
  - Do not install signal lines in parallel to the load lines.
  - Connect cable shields (see operating instructions 30232-02-B)
  - For digital inputs and outputs as well as command and actual value, the max. admissible cable length for unshielded cables is 30 m. With longer cable lengths, shielded cables are to be used.
  - The distance to radios must be sufficient (> 1 m).
  - With a strongly fluctuating operating voltage, in individual cases, it may be necessary to use an external smoothing capacitor with a capacity of at least 2200 µF.
- ▶ Recommendation: Capacitor module VT 11110 (see data sheet 30750); sufficient for up to 3 amplifier modules.
- ▶ The upper and lower ventilation slots must not be concealed by adjacent devices in order to provide for sufficient cooling.
- ▶ The devices have been tested in the plant and are supplied with default settings.

## Further information

- |  |                                   |
|--|-----------------------------------|
| ▶ Valve amplifier for proportional valves without electrical position feedback; maximum current limitation 1.5 A | Operating instructions 30232-02-B |
| ▶ Installation, commissioning and maintenance of proportional valves   | Data sheet 07800                  |
| ▶ Assembly, commissioning and maintenance of hydraulic systems   | Data sheet 07900                  |

**Notes**

## Notes

## Notes

Bosch Rexroth AG  
Industrial Hydraulics  
Zum Eisengießer 1  
97816 Lohr am Main, Germany  
Phone +49 (0) 93 52/ 40 30 20  
my.support@boschrexroth.com  
www.boschrexroth.com

© All rights reserved to Bosch Rexroth AG, also regarding any disposal, exploitation, reproduction, editing, distribution, as well as in the event of applications for industrial property rights.  
The data specified above only serve to describe the product. As our products are constantly being further developed, no statements concerning a certain condition or suitability for a certain application can be derived from our information. The information given does not release the user from the obligation of own judgment and verification. It must be remembered that our products are subject to a natural process of wear and aging.