

S20 analog input/output module 2 inputs, 2 outputs

R911346600
Edition 03

Data sheet S20-AIAO-2

2 analog inputs, 2 analog outputs
0 - 10 V, ± 10 V, 0 - 5 V, ± 5 V
0 - 20 mA, 4 - 20 mA, ± 20 mA
2-conductor technology

10 / 2025



1 Description

The module is designed for use within an S20 station.

It is used to acquire and output analog voltage and current signals.

Features

- 2 analog differential input channels
- Connection of sensors in 2-conductor technology
- Current ranges: 0 mA ... 20 mA, 4 mA ... 20 mA, ± 20 mA
- Voltage ranges: 0 V ... 10 V, ± 10 V, 0 V ... 5 V, ± 5 V
- 2 analog outputs
- Connection of actuators in 2-conductor technology
- Current ranges: 0 mA ... 20 mA, 4 mA ... 20 mA, ± 20 mA
- Voltage ranges: 0 V ... 10 V, ± 10 V, 0 V ... 5 V, ± 5 V
- Process data update < 150 μ s
- Device rating plate stored



This data sheet is only valid in association with the application description for the S20 system, material number R911335988.



Make sure you always use the latest documentation.

It can be downloaded under www.boschrexroth.com/electrics.

2 Table of contents

1	Description	1
2	Table of contents	2
3	Ordering data	3
4	Technical data	3
5	Tolerance data	7
6	Signal rise times	8
7	Internal circuit diagram	9
8	For your safety	10
9	Terminal point assignment	11
10	Connection examples	11
11	Connection notes	12
12	Local diagnostic and status indicators	13
13	Process data	14
14	Significant values in various formats	15
15	Parameter, diagnostics and information (PDI)	18
16	Standard objects	19
17	Application objects	27
18	Device descriptions	31

3 Ordering data

Description	Type	MNR	Pcs./Pkt.
S20 analog input/output module 2 inputs, 2 outputs	S20-AIAO-2	R911173743	1
Accessories	Type	MNR	Pcs./Pkt.
S20 bus base module, narrow	S20-BS-S	R911173203	5
S20 Shield set	S20-SHIELD-SET	R911173030	1
Shield connection clamps, for shield on busbars, for conductor diameters ≤ 5 mm, contact resistance < 1 m Ω	S20-SHIELD-SK5	R911173282	10
Shield connection clamps, for shield on busbars, for conductor diameters ≤ 14 mm, contact resistance < 1 m Ω	S20-SHIELD-SK14	R911173286	10
PEN conductor busbar, 3x10 mm, length: 1000 mm	S20-SHIELD-NLS	R911173283	1
Documentation	Type	MNR	Pcs./Pkt.
Application description S20: System and Installation	DOK-CONTRL- S20*SYS*INS-AP..-EN-P	R911335988	1
Application description S20: Error Messages	DOK-CONTRL- S20*DIAG*ER-AP..-EN-P	R911344826	1

Additional ordering data

For additional ordering data (accessories), please refer to the product catalog at www.boschrexroth.com/electrics.

4 Technical data

Dimensions (nominal sizes in mm)

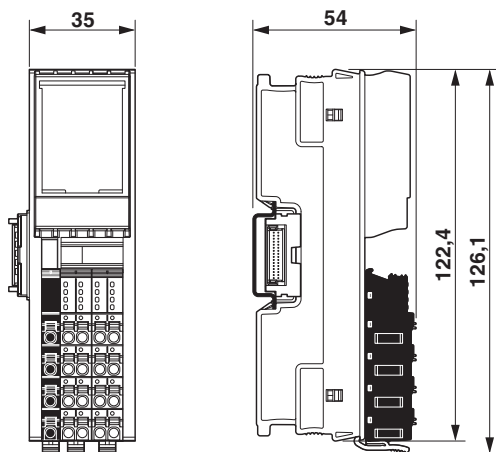

Width	35 mm
Height	126.1 mm
Depth	54 mm
Note on dimensions	The depth applies when a TH 35-7.5 DIN rail is used (in accordance with EN 60715).

General data

Color	Housing: light gray (RAL 7035)
Weight	200 g (with connectors and bus base module)
Ambient temperature (operation)	-25 °C ... 60 °C
Ambient temperature (storage/transport)	-40 °C ... 85 °C
Permissible humidity (operation)	5 % ... 95 % (non-condensing)
Permissible humidity (storage/transport)	5 % ... 95 % (non-condensing)
Air pressure (operation)	70 kPa ... 106 kPa (up to 3000 m above sea level)
Air pressure (storage/transport)	70 kPa ... 106 kPa (up to 3000 m above sea level)
Degree of protection	IP20
Protection class	III (IEC 61140, EN 61140, VDE 0140-1)
Overvoltage category	II (IEC 60664-1, EN 60664-1)
Degree of pollution	2 (IEC 60664-1, EN 60664-1)
Mounting type	DIN rail mounting
Mounting position	any (no temperature derating)

Connection data: S20 connector

Connection method	Push-in connection
Conductor cross-section, rigid	0.2 mm ² ... 1.5 mm ²
Conductor cross-section, flexible	0.2 mm ² ... 1.5 mm ²
Conductor cross-section [AWG]	24 ... 16
Stripping length	8 mm



Observe the specifications for the conductor cross-sections in the application description for the S20 system, material number R911335988.

Interface: Local bus

Number of interfaces	2
Connection method	Bus base module
Transmission speed	100 Mbps

Supply of the local bus (U_{Bus})

Supply voltage	5 V DC (via bus base module)
Current consumption	typ. 120 mA max. 150 mA

Supply for analog modules (U_A)

Supply voltage	24 V DC
Supply voltage range	19.2 V DC ... 30 V DC (including all tolerances, including ripple)
Current consumption	min. 30 mA (internal current consumption, no load, 0 V output) typ. 40 mA max. 60 mA (2 voltage channels, 10 V output, 2 k Ω load) max. 80 mA (2 current channels, 24 mA output, 500 Ω load)
Surge protection	electronic (35 V, 0.5 s)
Reverse polarity protection	Polarity protection diode
Transient protection	Suppressor diode

Power dissipation

Maximum power dissipation for nominal condition	2.75 W
---	--------

Analog inputs	
Number of inputs	2
Description of the input	Differential inputs, voltage or current can be chosen separately
Connection method	Push-in connection
Connection technology	2-conductor, shielded, twisted pair
Current input signal	0 mA ... 20 mA, 4 mA ... 20 mA, -20 mA ... 20 mA
Voltage input signal	0 V ... 5 V, -5 V ... 5 V, 0 V ... 10 V, -10 V ... 10 V
A/D converter resolution	16 bit
A/D conversion time	2 µs
Measured value representation	16 bits (15 bits + sign bit)
Data formats	IB IL, standardized representation
Process data update	150 µs
Input filter	30 Hz, 12 kHz and mean value generation (can be parameterized)
Tolerance, relative	typ. 0.1 % (of measuring range final value for active mean value generation and 30 Hz filter) see tables for tolerance values
Tolerance, absolute	see tables for tolerance values
Input resistance of voltage input	268 kΩ (typical)
Input resistance current input	104 Ω (typical)
Limit frequency (3 dB)	30 Hz 12 kHz
Wire-break behavior	goes to 0 V, 0 mA; open-circuit detection for 4 mA ... 20 mA
Common mode voltage range	-50 V DC ... 50 V DC
Transient protection of inputs	Suppressor diode
Overload protection of the current inputs	No; ±5.2 V DC, maximum, $I_{\max} = 50$ mA
Overload protection of the voltage inputs	±30 V DC, maximum
Analog outputs	
Number of outputs	2
Connection method	Push-in connection
Connection technology	2-conductor, shielded, twisted pair
Current output signal	0 mA ... 20 mA, 4 mA ... 20 mA, -20 mA ... 20 mA
Voltage output signal	0 V ... 5 V, -5 V ... 5 V, 0 V ... 10 V, -10 V ... 10 V
D/A converter resolution	16 bit
Representation of output values	16 bits (15 bits + sign)
Data formats	IB IL, standardized representation
Process data update	150 µs
Load/output load current output	≤ 500 Ω
Load/output load voltage output	≥ 2 kΩ
Tolerance, relative	typ. 0.1 % (of output range final value) see tables for tolerance values
Tolerance, absolute	see tables for tolerance values
Short-circuit and overload protection	electronic
Transient protection	Suppressor diode
Input and output address area	
Input address area	4 Byte
Output address area	4 Byte

Configuration and parameter data in a PROFIBUS system

Required parameter data	11 Byte
Required configuration data	7 Byte

Electrical isolation/isolation of the voltage areas

Test section	Test voltage
5 V supply of the local bus (U_{Bus}) / 24 V supply (I/Os)	500 V AC, 50 Hz, 1 min
5 V supply of the local bus (U_{Bus}) / analog inputs and outputs	500 V AC, 50 Hz, 1 min
5 V supply of the local bus (U_{Bus}) / functional ground	500 V AC, 50 Hz, 1 min
24 V supply (I/O) / analog inputs and outputs	500 V AC, 50 Hz, 1 min
24 V supply (I/O) / functional ground	500 V AC, 50 Hz, 1 min
Analog inputs and outputs/functional ground	500 V AC, 50 Hz, 1 min

Mechanical tests

Vibration resistance in accordance with EN 60068-2-6/IEC 60068-2-6	5g
Shock in accordance with EN 60068-2-27/IEC 60068-2-27	30g
Continuous shock in accordance with EN 60068-2-27/IEC 60068-2-27	10g

Conformance with EMC Directive 2014/30/EU**Immunity test in accordance with EN IEC 61000-6-2**

Electrostatic discharge (ESD) IEC 61000-4-2	Criterion B, ± 6 kV contact discharge, ± 8 kV air discharge
Electromagnetic fields IEC 61000-4-3	Criterion A, Field intensity: 10 V/m
Fast transients (burst) IEC 61000-4-4	Criterion B, ± 2 kV
Transient overvoltage (surge) IEC 61000-4-5	Criterion B, DC supply lines: ± 0.5 kV/ ± 1.0 kV (symmetrical/unsymmetrical), ± 1.0 kV to shielded I/O cables
Conducted interference IEC 61000-4-6	Criterion A, Test voltage 10 V
Noise emission test in accordance with EN IEC 61000-6-3	Class B

Approvals

For the current approvals, please visit www.boschrexroth.com/electrics.

5 Tolerance data

The following applies for tolerance values:

Analog inputs:

The data is valid for nominal operation ($U_A = 24\text{ V}$) in the default parameterization (unless documented otherwise).

Default parameterization: filter with 30 Hz, 16-sample mean value, IB IL format.

Analog outputs:

The data is valid irrespective of the parameterization.

Tolerances at $T_A = +25^\circ\text{C}$				
	Absolute		Relative	
	Typ.	Max.	Typ.	Max.
Analog inputs				
0 mA ... 20 mA, 4 mA ... 20 mA, $\pm 20\text{ mA}$	$\pm 20\ \mu\text{A}$	$\pm 60\ \mu\text{A}$	$\pm 0.10\ \%$	$\pm 0.30\ \%$
0 V ... 5 V, $\pm 5\text{ V}$, 0 V ... 10 V, $\pm 10\text{ V}$	$\pm 10\text{ mV}$	$\pm 30\text{ mV}$	$\pm 0.10\ \%$	$\pm 0.30\ \%$
Analog outputs				
0 mA ... 20 mA, 4 mA ... 20 mA, $\pm 20\text{ mA}$	$\pm 20\ \mu\text{A}$	$\pm 60\ \mu\text{A}$	$\pm 0.10\ \%$	$\pm 0.30\ \%$
0 V ... 5 V, $\pm 5\text{ V}$, 0 V ... 10 V, $\pm 10\text{ V}$	$\pm 10\text{ mV}$	$\pm 30\text{ mV}$	$\pm 0.10\ \%$	$\pm 0.30\ \%$

300 μs update time, 12 kHz filter, 32-sample mean value

Tolerances at $T_A = +25^\circ\text{C}$				
	Absolute		Relative	
	Typ.	Max.	Typ.	Max.
Analog inputs				
0 mA ... 20 mA, 4 mA ... 20 mA, $\pm 20\text{ mA}$	$\pm 100\ \mu\text{A}$	$\pm 160\ \mu\text{A}$	$\pm 0.5\ \%$	$\pm 0,8\ \%$
0 V ... 5 V, $\pm 5\text{ V}$, 0 V ... 10 V, $\pm 10\text{ V}$	$\pm 50\text{ mV}$	$\pm 80\text{ mV}$	$\pm 0.5\ \%$	$\pm 0,8\ \%$

Typical data contains offset error, gain error, and linearity error in the respective default setting.

All tolerances indicated as a percentage are related to the positive measuring range final value.

Please also observe the values for temperature drift and the tolerances under influences of electromagnetic interferences.

Tolerance and temperature response at $T_A = -25^\circ\text{C} \dots +60^\circ\text{C}$

	Drift	
	Typical	Maximum
Analog inputs		
0 mA ... 20 mA, 4 mA ... 20 mA, $\pm 20\text{ mA}$	$\pm 45\text{ ppm/K}$	$\pm 65\text{ ppm/K}$
0 V ... 5 V, $\pm 5\text{ V}$, 0 V ... 10 V, $\pm 10\text{ V}$	$\pm 40\text{ ppm/K}$	$\pm 55\text{ ppm/K}$
Analog outputs		
0 mA ... 20 mA, 4 mA ... 20 mA, $\pm 20\text{ mA}$	$\pm 65\text{ ppm/K}$	$\pm 80\text{ ppm/K}$
0 V ... 5 V, $\pm 5\text{ V}$, 0 V ... 10 V, $\pm 10\text{ V}$	$\pm 30\text{ ppm/K}$	$\pm 40\text{ ppm/K}$

The drift values refer to the relevant measuring range final value.

Additional tolerances influenced by electromagnetic interference

Electromagnetic fields	IEC 61000-4-3	$< \pm 0.3\ \%$
Fast transients (burst)	IEC 61000-4-4	$< \pm 1.2\ \%$
Conducted interference	IEC 61000-4-6	$< \pm 1.0\ \%$

Additional tolerances may occur due to the influence of high-frequency electromagnetic interference caused by wireless transmission systems in the immediate vicinity. The specified values refer to nominal operation. The components are directly exposed to interference without the use of additional shielding measures (e.g., steel cabinet).

The tolerances specified above can be reduced through additional shielding for the I/O module (e.g., use of a shielded control box/control cabinet, etc.).

6 Signal rise times

Voltage step 0 V ... 10 V (typical values)

Load	Time for 0 % ... 99 %
$R_L = 2 \text{ k}\Omega$	7.5 μs
$R_L = 2 \text{ k}\Omega$ II $C_L = 10 \text{ nF}$	15 μs
$R_L = 2 \text{ k}\Omega$ II $C_L = 220 \text{ nF}$	140 μs
$R_L = 2 \text{ k}\Omega$ $L_L = 3.3 \text{ mH}$	20 μs

Current step 0 mA ... 20 mA (typical values)

Load	Time for 0 % ... 99 %
$R_L = 500 \Omega$	20 μs
$R_L = 500 \Omega$ II $C_L = 10 \text{ nF}$	20 μs
$R_L = 500 \Omega$ II $C_L = 220 \text{ nF}$	240 μs
$R_L = 500 \Omega$ + $L_L = 3.3 \text{ mH}$	90 μs

Key to the tables

R_L	Ohmic load
C_L	Capacitive load
L_L	Inductive load
II	Parallel connection
+	Serial connection

7 Internal circuit diagram

Fig. 1 Internal wiring of the terminal points

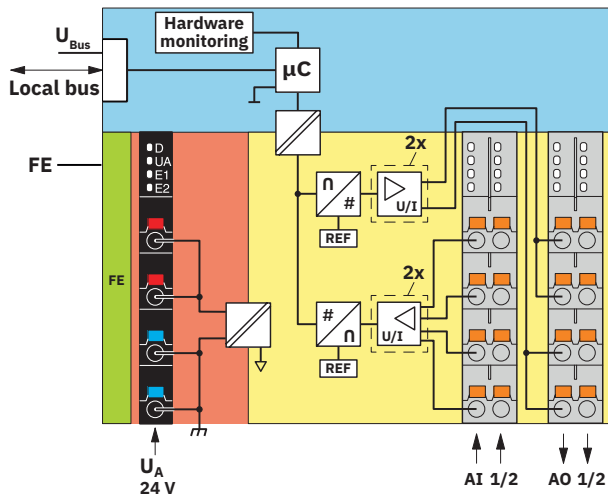

Key:

Local bus

FE

Local bus

Functional ground

Hardware monitoring



Microcontroller



Electrical isolation for data or power supply



Analog/digital converter



Digital/analog converter



Input amplifier for current (I) or voltage (U)



Output driver



Reference voltage source



Noiseless ground



Analog I/O reference ground



Logic reference ground



Reference ground of the supply voltage U_A



Electrically isolated areas



8 For your safety

8.1 Intended use

Only use S20 modules in accordance with the information in this data sheet and in the application description for the S20 system, material number R911335988.

If the equipment is used in a manner not specified, the protection provided by the equipment may be impaired.

8.2 Qualification of users

The use of products described in this data sheet is oriented exclusively to electrically skilled persons or persons instructed by them. The users must be familiar with the relevant safety concepts of automation technology as well as applicable standards and other regulations.

8.3 Electrical safety



WARNING Loss of electrical safety

If used incorrectly, device safety may be impaired.

During installation, startup, and operation, observe the notes in this data sheet and the specifications in the application description for the S20 system, material number R911335988.

8.4 Installation

Only install the S20 modules in a control cabinet or junction box.

NOTICE Fire hazard

- The device must be installed in the final protective housing, which provides sufficient resistance to mechanical strain and protection against the spreading of fire in accordance with the standards UL/IEC/EN 61010-1 and UL/IEC/EN 61010-2-201.
- The supply and external circuits intended to be connected to this device shall be galvanically separated from the mains supply or hazardous live voltage by reinforced or double insulation and meet the requirements of SELV/PELV (Class III) circuits of UL/CSA/IEC/EN 61010-1, UL/CSA/IEC/EN 61010-2-201.

NOTICE Damage to contacts or malfunction

Physical overloads can result in damage to the terminal points.

- Relieve strain in the connected cables.

9 Terminal point assignment

Fig. 2 Terminal point assignment

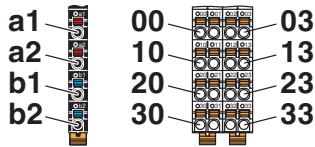

Terminal point	Color	Assignment	
Supply voltage input			
a1, a2	Red	24 V DC (U _A)	Supply for analog modules (bridged internally)
b1, b2	Blue	GND	Reference potential of the supply voltage (bridged internally)
Analog inputs		IN01, IN02	
00, 01	Orange	U1+, U2+	Positive voltage connection for channel 1 and 2
10, 11	Orange	U1-, U2-	Negative voltage connection for channel 1 and 2
20, 21	Orange	I1+, I2+	Positive current connection for channel 1 and 2
30, 31	Orange	I1-, I2-	Negative current connection for channel 1 and 2
Analog outputs		OUT01, OUT02	
02, 03	Orange	U1, U2	Voltage connection for channel 1 and 2
12, 13	Orange	I1, I2	Current connection for channel 1 and 2
22, 23	Orange	GND	Reference potential for all AO channels
32, 33	Orange	GND	Reference potential for all AO channels

10 Connection examples

Fig. 3 Connection for measuring voltage and current as well as voltage and current output

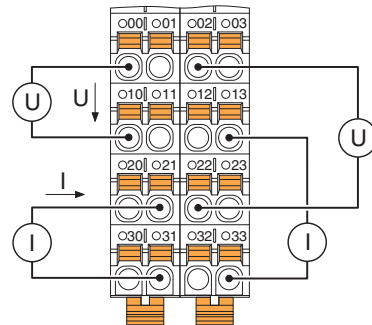

10.1 Analog inputs

Fig. 4 Connection for voltage and current measurement

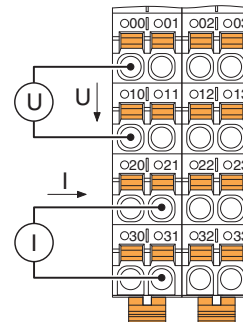
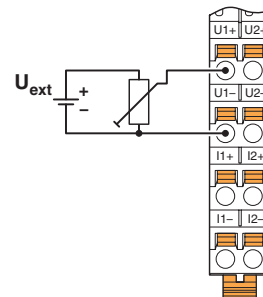

Fig. 5 Connection of potentiometric position sensors



The values of potentiometric position sensors can be acquired with voltage measurement. Supply the potentiometer via an external power supply unit (U_{ext} = 10 V).

Fig. 6 Connection of positimeters for detecting the position (OUT01 channel is used for supplying the positimeter)

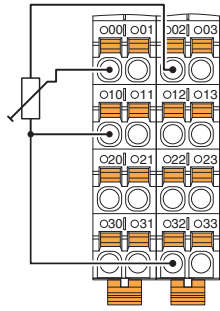

Fig. 7 Passive pressure sensor at a differential current input

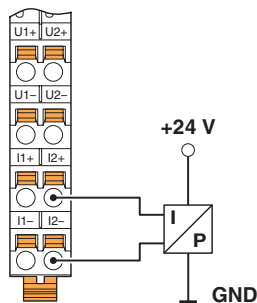
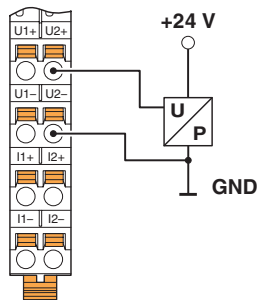
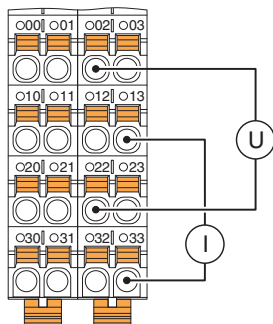

Fig. 8 Differential voltage input with active 3-conductor transmitter



10.2 Analog outputs

Fig. 9 Connection for voltage and current output



11 Connection notes

Observe the connection notes of the sensor and actuator manufacturers.

Shielding

Always connect the analog sensors and actuators using shielded twisted pair cables.

In environments with high levels of interference, unshielded cables may cause values to be outside the specified tolerance limits.

For installation in a control cabinet: Connect the cable shield to the functional ground at a suitable point immediately after entry into the control cabinet. Route the cable in the control cabinet in a shielded manner.

If a closed control cabinet is not available, connect the shield to a shield bus.

For the best possible connection directly in front of the module, use the S20 SHIELD-SET shield connection set (R911173030) in combination with the S20-SHIELD-NLS busbar (R911173283).

For more information on shielding, please refer to the application description for the S20 system, material number R911335988.

Strain relief

Do not use the shield contact as a strain relief. Carry out the shielding and the strain relief separately.

12 Local diagnostic and status indicators

Fig. 10 Local diagnostic and status indicators

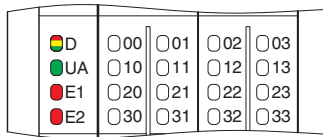

Channel errors are errors that can be associated with a channel.

I/O errors are errors that affect the entire module.

Designation	Color	Meaning	State	Description
D	Red/ yellow/ green	Diagnostics of local bus communication		
		Run	Green on	The device is ready for operation, communication within the station is OK. All data is valid. An error has not occurred.
		Active	Flashing green	The device is ready to operate, communication within the station is OK. The data is not valid. The controller or higher-level network is not delivering valid data. There is no error on the module.
		Device application not active	Flashing green/ yellow	The device is ready for operation, communication within the station is OK. Output data cannot be outputted and/or input data cannot be read. There is a fault on the periphery side of the module.
		Ready	Yellow on	The device is ready for operation but did not detect a valid cycle after power-up.
		Connected	Flashing yellow	The device is not (yet) part of the active configuration.
		Reset	Red on	The device is ready for operation but has lost the connection to the bus head.
		Not connected	Red flashing	The device is ready for operation but there is no connection to the previously existing device.
		Power down	Off	Device is in (power) reset.
UA	Green	U _{Analog}	On	Supply for analog modules (U _A) present.
			Off	Supply for analog modules (U _A) not present.
E1	Red	Supply voltage error	On	Supply for analog modules (U _A) is faulty.
			Off	Supply for analog modules (U _A) is OK.
E2	Red	Error	On	I/O or channel error has occurred.
			Off	No error

Error code and status of the E1 and E2 LEDs

Error	LED E1	LED E2
No error	off	off
Underrange	off	on
Overrange	off	on
Wire break	off	on
Supply voltage faulty (supply for analog modules (U _A))	on	on
Parameter table invalid	off	on
Device error	off	on
Flash format error	off	on



The error that can actually be reported depends on the measuring range. For additional information please refer to the tables with significant measured values in various formats.

13 Process data

The module uses two words of IN process data and two words of OUT process data.

The measured values are transmitted to the controller board or the computer using process data input words.

The output values are transmitted from the controller board or the computer to the module using process data output words.

Output word	0	1
Assignment	Output value OUT01	Output value OUT02
Signal	OUT01	OUT02
Terminal point (signal)	OUT01_U: 02, OUT01_I: 12	OUT02_U: 03, OUT02_I: 13
Terminal point (GND)	22, 23, 32, 33	

Input word	0	1
Assignment	Measured value IN01	Measured value IN02
Signal	IN01	IN02
Terminal point (signal)	IN01_U: 00, IN01_I: 20	IN02_U: 01, IN02_I: 21
Terminal point (-)	U1-: 10, I1-: 30	U2-: 11, I2-: 31

Each channel is mapped to a word.

The output values and measured values are depicted in IB IL format or standardized representation. For all formats, the measured value is displayed in 16-bit format. The data type for programming is Integer 16.

15	14	13	12	11	10	9	8	7	6	5	4	3	2	1	0
Analog value															

In IB IL and standardized representation format, a diagnostic code is mapped to the input data in the event of an error:

Code (hex)	Cause
8001	Measuring range exceeded (overrange)
8002	Wire break
8004	Measured value invalid or no valid measured value available
8010	Parameter table invalid
8020	Supply voltage faulty (supply for analog modules (U _A))
8040	Device faulty
8080	Below measuring range (underrange)

14 Significant values in various formats

14.1 Significant values in IB IL format



The measured values and output values are identical for input and output data, except in the event of overrange or underrange. Therefore, in these special cases, the values for the inputs and outputs are specified in the tables.

The table is valid from index -AB1.

I/O data		0 V ... 10 V	±10 V	0 V ... 5 V	±5 V	0 mA ... 20 mA	±20 mA	4 mA ... 20 mA
hex	dec	V	V	V	V	mA	mA	mA
8001	Overrange (output)	+10.837	+10.837	+5.419	+5.419	+21.6764	+21.6764	+21.3397
8001	Overrange (input)	> +10.837	> +10.837	> +5.419	> +5.419	> +21.6764	> +21.6764	> +21.3397
7FFF ... 7F01		+10.837	+10.837	+5.419	+5.419	+21.6764	+21.6764	+21.3397
7F00	32512	+10.837	+10.837	+5.419	+5.419	+21.6764	+21.6764	+21.3397
7530	30000	+10.0	+10.0	+5.0	+5.0	+20.0	+20.0	+20.0
3A98	15000	+5.0	+5.0	+2.5	+2.5	+10.0	+10.0	+12.0
0001	1	+333.33 µV	+333.33 µV	+166.67 µV	+166.67 µV	+0.6667 µA	+0.6667 µA	+4.0005333
0000	0	0	0	0	0	0	0	+4.0 ... +3.2
FFFF	-1		-333.33 µV		-166.67 µV		-0.6667 µA	
FED3	-301			-100 mV				
FDA7	-601	-200 mV						
C568	-15000		-5.0		-2.5		-10.0	
8AD0	-30000		-10.0		-5.0		-20.0	
8100	-32512		-10.837		-5.419		-21.6764	
80FF ... 8000 *	(Output)	Hold last value	Hold last value	Hold last value	Hold last value	Hold last value	Hold last value	Hold last value
8080	Underrange (output)	-200 mV	-10.837	-100 mV	-5.419		-21.6764	Hold last value
8080	Underrange (input)	< -200 mV	< -10.837	< -100 mV	< -5.419	< -0.44	< -21.6764	
8002	Wire break							< +3.2

* Without 8001, 8002, 8080

The maximum output value or measured value is 7F00_{hex}.

Depending on the output range or measuring range, the minimum output value or measured value is 0000_{hex} or 8100_{hex}.

14.2 Significant values in standardized representation format



The measured values and output values are identical for input and output data, except in the event of overrange or underrange. Therefore, in these special cases, the values for the inputs and outputs are specified in the tables.

The table is valid from index -AB1.

I/O data		0 V ... 10 V	±10 V	0 V ... 5 V	±5 V	0 mA ... 20 mA	±20 mA	4 mA ... 20 mA
hex	dec	V	V	V	V	mA	mA	mA
8001	Overrange (output)	+10.837	+10.837	+5.419	+5.419	+21.674	+21.674	+21.339
8001	Overrange (input)	> +10.837	> +10.837	> +5.419	> +5.419	> +21.674	> +21.674	> +21.339
54AA	21674					+21.674	+21.674	
4E20	20000					+20.0	+20.0	
43BB	17339							21.339
2A55	10837	+10.837	+10.837					
2710	10000	+10.0	+10.0			+10.0	+10.0	+14.0
152B	5419			+5.419	+5.419			
1388	5000	+5.0	+5.0	+5.0	+5.0	+5.0	+5.0	+9.0
0001	1	+0.001	+0.001	+0.001	+0.001	+0.001	+0.001	+4.001
0000	0	0	0	0	0	0	0	+4.0 ... +3.2
FFFF	-1		-0.001		-0.001		-0.001	
FF9C	-100			-100 mV				
FF38	-200	-200 mV						
EC78	-5000		-5.0		-5.0		-5.0	
EAD5	-5419				-5.419			
D8F0	-10000		-10.0				-10.0	
D5AB	-10837		-10.837					
B1E0	-20000						-20.0	
8080	Underrange (output)		-10.837		-5.419		-21.674	
8080	Underrange (input)	< -200 mV	< -10.837	< -100 mV	< -5.419	< -0.44	< -21.674	
8002	Wire break							< +3.2

Depending on the output range or measuring range, the maximum output value or measured value is 54AA_{hex}, 43BB_{hex} or 152B_{hex}.

Depending on the output range or measuring range, the minimum output value or measured value is EAD5_{hex}, D5AB_{hex} or AB56_{hex}.

14.3 Calculation of the measured value from the process data input value

The following examples explain the calculation of the measured value from the process data input value for the measuring range 4 mA to 20 mA.

PD IW = Process data input word = input data

IB IL format

Resolution = $(20 \text{ mA} - 4 \text{ mA}) / 30000 = 0.0005333$

Measured value = PD-EW x 0.0005333 mA + 4 mA

Example 1

PD IW	$493F_{\text{hex}} = 18751_{\text{dec}}$
Value x resolution	$18751 \times 0.000533 \text{ mA} = 10 \text{ mA}$
+ 4 mA	$10 \text{ mA} + 4 \text{ mA} = 14 \text{ mA}$
Measured value	14 mA

15 Parameter, diagnostics and information (PDI)

15.1 PDI objects

The module has PDI objects. They are used to map parameters, diagnostic data, and information about the module. The PDI objects can be read and/or written acyclically.

In IndraWorks, these parameters are displayed in the configurator.

You can find out how to access the PDI objects in the documentation for the bus coupler or the controller used.

The PDI objects created in the module are described in the following sections.

For an explanation of the data types, please refer to the application description for the S20 system, material number R911335988.

The following applies to all tables below:

Abbreviation	Meaning
Length in bytes	Maximum length of the elements in bytes
R	Read
W	Write
[x]	Number of elements in an array or record



Each visible string is terminated with a null terminator (00_{hex}). The length of a visible-string-type element is therefore at least one byte larger than the number of user data items.

If the number of user data items plus null terminator is smaller than the specified length of the element, the visible string will be populated with a null character (00_{hex}).



For detailed information on PDI objects, please refer to the application description for the S20 system, material number R911335988.

15.2 Retentive storage

S20 modules can have retentively (non-volatilely) and volatilely stored parameters.

Retentively stored parameters retain their values even after the module voltage is reset.

When the parameterization is reset (via object 002D_{hex}), certain retentively stored parameters are reset to their default settings. You can find out which parameters are reset in the description for object 002D_{hex}.

For writeable parameters, the following tables indicate whether they are stored retentively or volatilely.

A write operation to the module memory is only triggered if the value of at least one retentive parameter has been changed.

Due to the storage technology used, parameters that are stored retentively only allow a certain number of write access operations (typ. 100,000 to 1,000,000 times). **They are not suitable for being changed cyclically.**

NOTICE Damage to the Flash memory during cyclic write access

The flash memory is only designed for a limited number of write access operations.

- Make sure that write access operations are not performed too often and, in particular, are not performed cyclically.
- Note this behavior when programming function blocks.
- For systems with initial parameterization (e.g., PROFINET), avoid parameterization from the application program.

16 Standard objects

16.1 Objects for identification (device rating plate)



You can only access these objects via subindex 00, i.e., you access the entire object in each case.

If an object contains several elements, the content is listed in the table in a structured way, e.g. hardware version divided into date and version.

Index (hex)	Object name	Data type	Length in bytes	Rights	Meaning	Contents
Manufacturer						
0001	VendorName	Visible String	17	R	Vendor name	Bosch Rexroth AG
0002	VendorID	Visible String	7	R	Vendor ID	006034
0012	VendorURL	Visible String	28	R	Vendor URL	http://www.boschrexroth.com
Module - general						
0004	DeviceFamily	Visible String	18	R	Device family	I/O analog IN-OUT
0006	ProductFamily	Visible String	17	R	Product family	S20
000E	CommProfile	Visible String	4	R	Communication profile	633
000F	DeviceProfile	Visible String	5	R	Device profile	0010
0011	ProfileVersion	Record [2] of Visible Strings	32	R	Profile version	2011-12-07; Basic - Profile V2.0
0017	Language	Record [2] of Visible Strings	14	R	Language	en-us; English
Module - special						
0005	Capabilities	Visible String	8	R	Capabilities	Energ_0
0007	ProductName	Visible String	11	R	Product name	S20-AIAO-2
0008	SerialNo	Visible String	16	R	Serial number	xx xx xx xx xx xx xx x (e. g., 7602012346BC125)
0009	ProductText	Visible String	50	R	Product text	2 analog input channels, 2 analog output channels
000A	OrderNumber	Visible String	11	R	Item No.	R911173743
000B	HardwareVersion	Record [2] of Visible Strings	15	R	Hardware version	e.g., 2020-04-26; AA1
000C	FirmwareVersion	Record [2] of Visible Strings	17	R	Firmware version	e. g., 2010-06-21; V1.10
000D	PChVersion	Record [2] of Visible Strings	17	R	PDI version	2010-01-08; V1.00
0037	DeviceType	Octet string	8	R	Device type	00 30 00 08 00 00 00 A9 _{hex}
003A	VersionCount	Array [4] of UINT16	8	R	Version counter	e. g., 0007 0001 0001 0001 _{hex}
Use of the device						
These parameters are stored retentively. They are retained when the voltage is reset and when the parameterization is reset (via object 002D _{hex}).						
0014	Location	Visible String	59	R/W	Location	Can be completed by the user.
0015	EquipmentIdent	Visible String	59	R/W	Equipment identifier	Can be completed by the user.
0016	ApplDeviceAddr	UINT16	2	R/W	Application-specific device address	Can be completed by the user.

16.2 Miscellaneous standard objects

Index (hex)	Object name	Data type	Length in bytes	Rights	Meaning/contents	Retentive storage	
Diagnostics objects							
0018	DiagState	Record [6]	21	R	Diagnostic state		*
0019	ResetDiag	UINT8	1	R/W	Handling diagnostic messages	No	*
Objects for process data management							
0024	ResetCode	Array [2] of UINT16	4	R/W	Substitute value behavior during bus reset (PDOOUT)	Yes	*
0025	PDIN	Octet string	4	R	Input process data The structure corresponds to the representation in the "Process data" section.		
0026	PDOOUT	Octet string	4	R/W	OUT process data The structure corresponds to the representation in the "Process data" section.	No	*
0027	GetExRight	UINT8	1	R/W	Get exclusive process data write rights	No	*
002F	PDOOUT_Subst	Array of UINT16	4	R/W	Substitute value for the OUT process data	Yes	*
Objects for device management							
001D	Password	Octet string	9	W	Password	No	*
0029	ParamSetWrite-Control	UINT8	1	R/W	Parameter set write control	No	*
002A	ConflictDictionary	UINT8	12	R	Conflict dictionary		*
002D	ResetParam	UINT8	1	R/W	Reset parameterization	No	*
002E	Checksum	UINT32	4	R	Checksum		*

The objects identified with * in the last column are described in more detail in the following sections.

The description of the other objects is to be found in the application description for the S20 system, material number R911335988.

16.3 Diagnostics state (0018_{hex}: DiagState)

This object is used for a structured message of an error.

Read off all information via subindex 00 to receive all information on an error number. Access to individual elements of the object is not permitted.

0018 _{hex} : Diagnostics state (read)					
Subindex/ element	Data type	Length in bytes	Meaning	Contents	
0	Record	21	Diagnostic state	Complete diagnostics information	
1	UINT16	2	Error number	0 ... 65535 _{dec}	
2	UINT8	1	Priority	00 _{hex}	No error
				01 _{hex}	Error
				02 _{hex}	Warning
				81 _{hex}	Error removed
				82 _{hex}	Warning eliminated
3	UINT8	1	Channel/group/module	00 _{hex}	No error
				01 _{hex}	Channel 1
				:	:
				04 _{hex}	Channel 4
				FF _{hex}	Entire device
4	UINT16	2	Error code	See table below	
5	UINT8	1	Additional information	00 _{hex}	
6	Visible String	14	Text	See table below	

 The message with priority 81_{hex} or 82_{hex} is a one-off, internal message to the bus coupler. The bus coupler transfers this error message to the error mechanisms of the higher-level system.

 Once the cause of the fault has been removed, the message is automatically reset.

Error and status of the local diagnostics and status indicators

Element	2	3	4	6		LED			
Error	Priority	Channel/ group/ module	Error code	Text	Process data	D	UA	E1	E2
	hex	hex	hex						
No error	00	00	0000	Status OK	xxxx	●	●	○	○
Short-circuit	01	03 ... 04	2130	Short-circuit	--	●	●	○	●
Supply voltage faulty (supply for analog modules (U _A))	01	FF	5160	Supply fail	8020	⚡	○	●	●
Device error	01	FF	6301	CS FLASH	8040	●	●	○	●
Flash format error	01	FF	6302	FO FLASH	8040	●	●	○	●
Parameter table invalid	01	FF	6320	Invalid para	8010	●	●	○	●
Wire break	01	01 ... 04	7710	Open circuit	8002	●	●	○	●
Overrange	02	01 ... 02	8910	Overrange	8001	●	●	○	●
Underrange	02	01 ... 02	8920	Underrange	8080	●	●	○	●

Key:

- On
- Off
- ⚡ Flashing green/yellow
- Green on

Special notes for the analog outputs

In the event of errors at the outputs, no process data codes are written to the input data, only a message is generated via the DiagState object.

The following two error messages are supported:

Wire break: current output, but open terminal blocks

Short circuit: voltage output, but short circuit between the terminal points

A wire break or short circuit is only indicated when the process data value of the channel is $> 512_{\text{dec}}$, corresponding to 1.7% of the output range final value.

16.4 Handling diagnostic messages (0019_{hex}: ResetDiag)

You can use this object to specify how the module should handle diagnostic messages.

Handling diagnostic messages	
Code (hex)	Meaning
00	Permit all diagnostic messages (default)
02	Delete all diagnostic messages that are still pending
06	Delete all diagnostic messages and do not permit new ones
Other	Reserved

16.5 Substitute value behavior during bus reset (PDOOUT) (0024_{hex}: ResetCode)

With this object, you parameterize the behavior of the module in the event that process data is missing.

After a reset, the module operates with the last retentively stored data. In the delivery state, the module works with the default data (default setting).

0024 _{hex} : substitute value behavior during bus reset (PDOOUT) (read, write)			
Subindex	Data type	Length in bytes	Meaning
0	Array [2] of UINT16	4	Substitute value behavior during bus reset (PDOOUT)

Element	Data type	Length in bytes	Meaning	Contents	Default value
1	UINT16	2	Behavior of channel OUT01	0000 ... 0003 _{hex}	0002 _{hex}
2	UINT16	2	Behavior of channel OUT02	0000 ... 0003 _{hex}	0002 _{hex}

Value range:

Code (hex)	Behavior
0000	Output of zero value (0 V / 0 mA / 4 mA) at output
0001	Output of final value (10 V / 5 V / 20 mA) at output
0002	Hold last value (default)
0003	Substitute value (PDOOUT): Copy the substitute value from the "Substitute value for the output process data" object (002F _{hex})

Behavior of the outputs when the supply voltage fails

U _A	U _{Bus}	Behavior of the outputs
Available	Available	Nominal operation or see object 0024 _{hex}
Missing	Available	Outputs to 0 V/0 mA
Available	Missing	Hold the last values (as with object 0024 _{hex} , code 0002)



If there is a requirement that a reset of the output value to 0 V or 0 mA is always expected, the output cable can be interrupted by a relay controlled by the application.

Special features

- You can only access this object via subindex 0, i. e., you access the entire object.
- In the case of valid parameters, the object is stored permanently.
- After resetting, the module works with the last permanently stored data. Upon delivery, the module works with the default data (default settings).

For error message, see object 0080_{hex}.

16.6 Output process data (0026_{hex}: PDOUT)

You can read or write the OUT process data of the module with this object.

The structure corresponds to the representation in the "Process data" section.

There are 2 bytes available for each channel, starting with channel 1.

Observe the notes in the section "Writing the analog values via the PDI channel".

16.7 Request exclusive write access (0027_{hex}: GetExRight)

This object allows you to determine which channel (process data channel or PDI channel) gets the rights for writing the outputs.

Get exclusive process data write rights	
Code (hex)	Meaning
00	Rights for writing output data over the PD channel (process data channel)
01	Rights for writing output data via the PDI channel

All other values are invalid and will be acknowledged with an error.



Please note the following for your process:

The parameterization in object 0027_{hex} "Rights for writing the output data via the PDI channel" overwrites the output process data transmitted via the process data channel with the values from object 0026_{hex} PDOUT.

From now on, changes to the output process data can only be made via the PDI object. Changes on the process data channel will have no effect.

If the value from the process data channel is to be used again, write access must be changed to "Rights for writing the output data via the PD channel (process data channel)" via the GetExRight object.

After a power reset, the values transmitted via the process data channel are always valid.

16.8 Substitute value for the OUT process data (002F_{hex}: PDOUT_Subst)

This object is used to parameterize the substitute values that are to be output at the analog outputs in the event that process data is missing. The condition is that option 0003 is selected in the "Substitute value behavior when process data is missing" object (0024_{hex}).

In the case of valid parameters, the parameterization is stored retentively in the module.

After a reset, the module operates with the last retentively stored data. In the delivery state, the module works with the default data (default setting).

There are 2 bytes available for each channel, starting with channel 1.

The values are used in the parameterized format.

Example:

Channel 1: 1 V, channel 2: 2 V, IB IL format
0B B8 17 70

Special features

- You can only access this object via subindex 0, i. e., you access the entire object.
- In the case of valid parameters, the object is stored permanently.
- The parameterized values are compared with the selected output range. If the substitute value does not correspond to the output range, an error message is issued.

For error message, see object 0080_{hex}.

16.9 Password (001D_{hex}: Password)

This object can be used to enable protected module functions, e.g., for the GetExRight object.

16.10 Parameter record write control (0029_{hex}: ParamSetWriteControl)

This object is used to control block parameterization.

Parameter set write control	
Code (hex)	Meaning
00	Termination of block parameterization
01	Initiation of block parameterization

Block parameterization serves to enable the joint transfer of interdependent parameters.

If you attempt to parameterize dependent parameters individually, this may result in the error message "Dependency of other parameter not taken into consideration". Block parameterization should be used in this case.

The plausibility check for the parameterization data is disabled during block parameterization, the data is only stored temporarily. However, the data length and subindex are checked.

The plausibility check is only performed when block parameterization is terminated with data item 00_{hex}. If the check was completed with no errors, the temporarily stored parameterization data is applied and stored in the Flash memory.

If errors were detected in the temporarily stored parameterization data, the service is acknowledged negatively.

The exact cause of the error can be read in object 002A_{hex}. The error codes are indicated by object 0080_{hex}.

You do not necessarily have to write all the startup objects.

The following actions are carried out when the parameter contents are modified:

Write control changes from 00_{hex} to 01_{hex}: initiation of block parameterization

- Block parameterization is initiated
- Conflict dictionary is reset

Write control changes from 01_{hex} to 00_{hex}: termination of block parameterization

- Block parameterization is terminated
- Individual parameterization is active
- Parameterization is checked for compatibility

Parameters are compatible:

- The parameter contents are accepted.
- Write access to the write control parameter is acknowledged positively.

Parameters are not compatible:

- The old contents of all the parameters required for block parameterization remain in effect.
- The conflict dictionary is updated.
- Write access to the write control parameter is acknowledged negatively.

Error code in the event of negative acknowledgment:

Code (hex)	Additional code (hex)	Meaning	Corrective
0800 or 0801	0030	Parameter value has left the value range.	Check the parameterization.
	0040	Dependent values were not taken into consideration.	

To use block parameterization without tools, proceed in the following sequence:

- Initiate block parameterization by writing the value 01_{hex} to object 0029_{hex}.
- Write the parameter table (ParaTable) to object 0080_{hex}.
- Write the substitute value behavior when process data is missing (ResetCode) to object 0024_{hex}.
- Write the substitute value for the OUT process data in the event of an error (PDOOUT_Subst) to object 002F_{hex}.
- Terminate block parameterization by writing the value 00_{hex} to object 0029_{hex}.

16.11 Conflict dictionary (002A_{hex}: ConflictDictionary)

This object contains the indices and error messages (additional code) for the parameters involved in the conflict.

002A _{hex} : Conflict dictionary (read)			
Subindex	Data type	Length in bytes	Meaning/contents
0		12	Conflict dictionary

Meaning	Length in bytes	Example	
Subslot	1	00	No subslot
Index	2	00 2F	PDOOUT_Subst
Subindex	1	02	Substitute value for OUT02
Parameter number	2	0001	
Error code and class	2	0080	
Additional error code	4	0000 0240	Substitute value for OUT02 outside the limit values

16.12 Reset parameterization (002D_{hex}: ResetParam)

This object is used to reset the module to the default settings.

To reset the parameters, value 01_{hex} must be transferred during write access. All other values are invalid and will be acknowledged with an error.

Then the default settings of the channels are loaded and all the user-set parameters are reset.

16.13 Checksum (002E_{hex}: CheckSum)

The module calculates the checksum for all retentively stored PDI objects (without 0014_{hex} to 0016_{hex}).

As long as the checksum does not change, the PDI objects of the module are not saved again.

17 Application objects

Index (hex)	Object name	Data type	Length in bytes	Rights	Meaning/contents	Retentive storage
0080	ParaTable	Array [6] of UINT16	12	R/W	Parameter table	Yes
0082	Measured Value Float	Array [2] of Records	12	R	Measured values in the extended float format	
0083	PD Min	Array [2] of UINT16	4	R	Minimum process data value	
0084	PD Max	Array [2] of UINT16	4	R	Maximum process data value	
00F1	StartupObjects	Octet string	11	R	Startup objects	

17.1 Parameter table (0080_{hex}: ParaTable)

Parameterize the module using this object.

In the case of valid parameters, the parameterization is stored retentively in the module.

After a reset, the module operates with the last retentively stored data. In the delivery state, the module works with the default data (default setting).

0080 _{hex} : Parameter table (read, write)				
Subindex	Data type	Length in bytes	Meaning	Default value
0	Array of UINT16	6 * 2	Read/write all elements	See subindices
1	UINT16	2	Parameterization of channel IN01	0000 _{hex}
2	UINT16	2	Parameterization of channel IN02	0000 _{hex}
3	UINT16	2	Parameterization of channel OUT01	0000 _{hex}
4	UINT16	2	Parameterization of channel OUT02	0000 _{hex}
5	UINT16	2	Data format	0000 _{hex}
6	UINT16	2	Reserved	0000 _{hex}

Parameterization of channel IN01/02, OUT01/02

Parameterization word

Parameterization of the analog inputs															
15	14	13	12	11	10	9	8	7	6	5	4	3	2	1	0
0	0	0	Filter	0	0	Mean value	0	0	0	0	Measuring range				

Parameterization of the analog outputs															
15	14	13	12	11	10	9	8	7	6	5	4	3	2	1	0
0	0	0	0	0	0	0	0	0	0	0	0	0	0	0	Output range

Filter	Code (bin)	Code (hex)
30 Hz (default)	0	0
12 kHz	1	1

Measuring/output range	Code (bin)	Code (hex)
0 V ... 10 V (default)	0000	0
-10 V ... +10 V	0001	1
0 V ... 5 V	0010	2
-5 V ... +5 V	0011	3
0 mA ... 20 mA	0100	4
-20 mA ... +20 mA	0101	5
4 mA ... 20 mA	0110	6
Reserved	0111 ... 1110	7 ... E
Channel inactive	1111	F

 Parameterize unused channels as "Channel inactive".

Mean value	Code (bin)	Code (hex)
16-sample (default)	00	0
No mean value	01	1
4-sample	10	2
32-sample	11	3

Data format

15	14	13	12	11	10	9	8	7	6	5	4	3	2	1	0
0	0	0	0	0	0	Data format	0	0	0	0	0	0	0	0	0

Data format	Code (bin)	Code (hex)
IB IL (default)	00	0
Reserved	01	1
Reserved	10	2
Standardized representation	11	3

 Set all reserved bits to 0.

The validity of the values parameterized in object 0080_{hex} (ParaTable) is checked.

If everything is OK, the specifications for object 0024_{hex} (ResetCode) and object 002F_{hex} (PDOOut_Subst) are checked as these depend on the output range and format.

If errors are detected, they are indicated with additional error code xx40_{hex} (collision with other values).

In the case of an invalid parameterization value, a negative write conformation with the error message 08, 00, xx30_{hex} is generated.

The low byte of the additional error code is 30_{hex} (value is out of range), the high byte contains the number of the element in question.

Example: ParaTable is completely filled with data (subindex 0) and the entry for channel 2 is invalid. In this case the error message is 8, 0 with additional error code 0230_{hex}.

In the case of valid parameters, ParaTable is stored permanently.

The stored data is verified with a checksum. After powering up, ParaTable, together with the substitute values (object 002F_{hex}) and the value for the behavior when process data is missing (object 0024_{hex}) are loaded from the Flash memory.

Error messages:

Parameterization error	Code (hex)	Additional code (hex)	Meaning	Corrective
Object 0080 _{hex} , subindex = 0, length ≠ 12 bytes	0605	0000	Inconsistent object attributes	Check the call.
Object 0080 _{hex} , subindex ≠ 0, length ≠ 2 bytes	0605	0000	Inconsistent object attributes	
The element contains an invalid value	0800	xx30	A reserved bit was set or a reserved code was used during parameterization xx: number of the element in question 30: value is out of range	Check the parameterization.
The ResetCode for channel xx is set to 0003 _{hex} and the substitute value is outside the process data limit values	0800	xx40	Collision with other values	
	0800	0540	Channel OUT01, substitute value > positive limit value	
	0800	1540	Channel OUT01, substitute value < negative limit value	
	0800	2540	Channel OUT02, substitute value > positive limit value	
	0800	3540	Channel OUT02, substitute value < negative limit value	

17.2 Measured value in extended float format (0082_{hex}: Measured Value Float)

You can read the IN process data with the 0025_{hex} object.

The 0082_{hex} object is also available.

This object provides the measured value in the highest internal accuracy of the terminal in the float format.

0082 _{hex} : Measured value in extended float format (read)			
Subindex	Data type	Length in bytes	Meaning
0	Array [2] of Records	12	Read all elements
1	Record	6	Measured value IN01
2	Record	6	Measured value IN02

Measured values IN01 and IN02

Element	Data type	Length in bytes	Meaning
1	FLOAT32	4	Measured value in float format according to IEEE 754
2	UINT8	1	Status
3	UINT8	1	Unit

Structure of the float format according to IEEE 754 in the bit representation:

VEEE EEEE	EMMM MMMM	MMMM MMMM	MMMM MMMM
-----------	--------------	--------------	--------------

V 1 sign bit, 0: positive, 1: negative

E 8 bits exponent with offset 7F_{hex}

M 23 bits mantissa

Example values for conversion from floating point to hexadecimal representation:

Floating point	Hexadecimal representation
1.0	3F 80 00 00
10.0	41 20 00 00
1.03965528	3F 85 13 6D
-1.0	BF 80 00 00

Extended Float Format

Extended Float Format is a specially defined format. It consists of the measured value in float format, a status, and a unit.

Status is necessary because the float format defines no patterns providing information on the status of the numerical value.

The status corresponds to the LSB of the diagnostic code in IB IL format (e.g., overrange: status = 01, diagnostic code = 8001_{hex}). If status = 0, the measured value is valid.

Unit	Code
Milliampere (mA)	39 (27 _{hex})
Volt (V)	58 (3A _{hex})

Status	Code
Measured value is valid	00 _{hex}
Measured value invalid	Other

17.3 Minimum process data value (0083_{hex}: PD Min)

Object 0083_{hex} can be used to read the minimum IN process data values.

The values are initialized after each parameterization. The highest value is assigned for the minimum process data value.

PD Min = 7FFF 7FFF_{hex}

On every analog conversion, the PD Min value is compared with the current measured values and overwritten if necessary.

0083 _{hex} : Minimum process data value (read)			
Subindex	Data type	Length in bytes	Meaning
0	Array [2] of UINT16	4	Read all elements
1	INT16	2	Minimum process data value channel IN01
2	INT16	2	Minimum process data value channel IN02

17.4 Maximum process data value (0084_{hex}: PD Max)

Object 0084_{hex} can be used to read the maximum IN process data values.

The values are initialized after each parameterization. The lowest value is assigned for the maximum process data value.

PD Max = 8000 8000_{hex}

On every analog conversion, the PD Max value is compared with the current measured values and overwritten if necessary.

0084 _{hex} : Maximum process data value (read)			
Subindex	Data type	Length in bytes	Meaning
0	Array [2] of UINT16	4	Read all elements
1	INT16	2	Maximum process data value channel IN01
2	INT16	2	Maximum process data value channel IN02

18 Device descriptions

The device is described in the device description files. These files are available for download at www.boschrexroth.com/electrics in the download area of the bus coupler used.